

Dakota Digital

PGR-1000 SERIES Programmable Gear Readout

See back page for alternative wiring for bikes w/ECM tach output

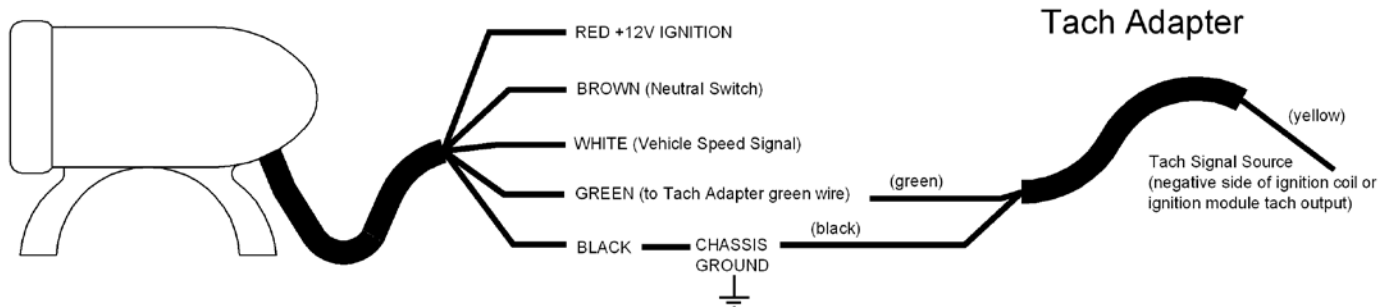

Display readout:

- 'n' -transmission in neutral
- '-' -no speed or rpm signal. (key on with engine off)
- '0' -engine is running, but no speed signal. (key on with engine on)
- 'E' -speed signal is present, but no rpm signal.
- '1' – '7' -current transmission gear.
- 'C' -settings cleared and waiting to learn gear pattern.

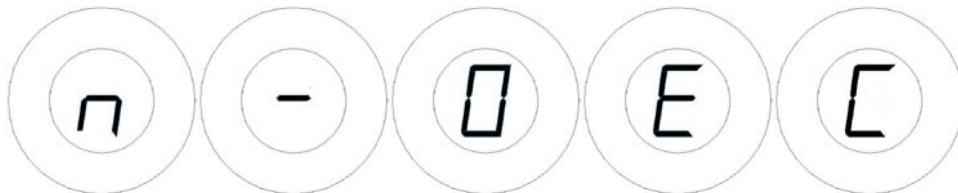

Programming:

When the display shows a flashing 'C' or 'n' it is ready to start learning the gear pattern.

(If your initial stretch of road will not allow you to reach top gear, please try to avoid shifting into 3rd gear until you have a long stretch of road in front of you.)

- After you start the engine you should see a flashing '0'.
- Once you start driving this will change to a flashing '1'.
- Drive at a constant speed in 1st gear for 20-25 seconds. Once the display quits flashing, shift to 2nd.
- Drive at a constant speed in 2nd gear for 20-25 seconds. Once the display quits flashing, shift to 3rd.
- Repeat these steps until you have programmed all of the gears in order. Once you stop or shift into neutral the settings will all be saved and the readout will begin normal operation.

Clearing or resetting the gear programming, or if PGR is **mounted below the handle-bars**:

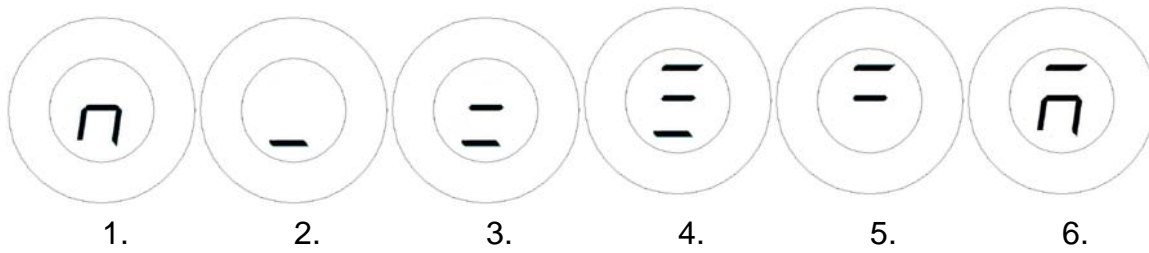

1. Turn the key on and make sure the transmission is in neutral and 'n' is displayed on the readout.(Please leave the key 'ON' for about 5 seconds before continuing)
2. Turn the key off (**.1 seconds**) and then back on (**1 second**) again rapidly. The display should show 1 bar. If you wait too long before continuing the readout will exit the setup routine. (If the unit has already been cleared, it will immediately jump to step 6.)
3. Repeat step #2. The display should show 2 bars.
4. Repeat step #2. The display should show 3 bars.
5. Repeat step #2. The display should show 2 bars.
6. Repeat step #2. The display should show 'n' with a bar over it. If the display is upside down then kick the transmission out of neutral and the display will invert and show 'C'.

Tach adapter(for open-collector tach signal from ECM w/out pull-up resistor)
(2004+ Victory motorcycles use this option, most other bikes use application on front page)

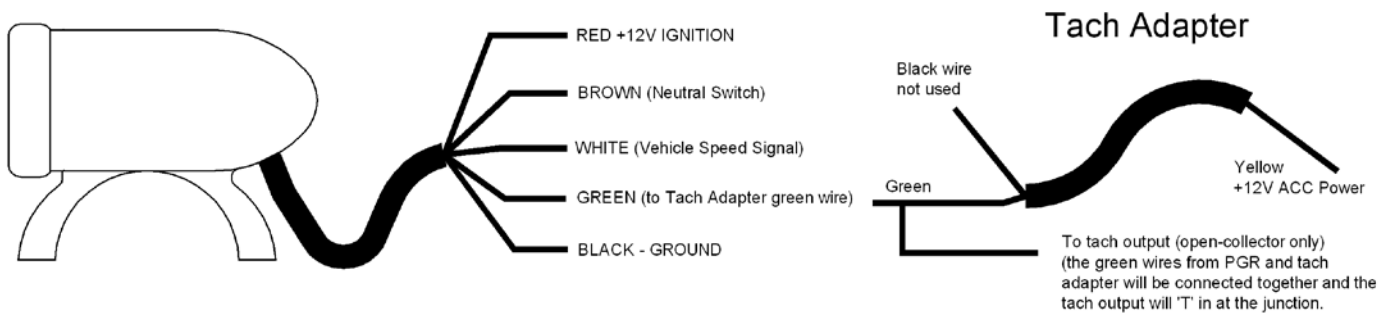

VSS Notes:

The PGR-1000 is designed for motorcycles with an Electronic VSS signal. Most modern motorcycles use a 3-wire hall-effect type speed sensor in the transmission with a power, ground, and a signal wire. The SEN-1019 is available for motorcycles without a factory VSS signal, fabrication will be required for sensor mounting.

1996-2003 Harley Davidson wiring

All signal wires should be found behind the speedometer or tachometer along with power and ground. Neutral should be at the indicator lights.

Signal	Wire Color
Speed	White/Green
Tach	Pink
Neutral	Tan
Power	Orange
Ground	Black

2004-2007 Harley Davidson wiring

The power, ground, and neutral can be found behind the speedometer and indicator lights. Speed signal and Tach need to be run to the ECU or cruise control module where you should find the wire colors listed here. This is due to the data bus configuration.

Signal	Wire Color
Speed	White/Green (Pin 33 @ ECU)
Tach	Pink (Pin 3 @ ECU)
Neutral	Tan
Power	Orange
Ground	Black

2008-2009 Harley Davidson wiring

The power, ground, and neutral can be found behind the speedometer and indicator lights. Speed signal and Tach need to be run to the ECU or cruise control module where you should find the wire colors listed here. This is due to the data bus configuration.

Signal	Wire Color
Speed	White/Green (Pin 40 @ ECU)
Tach	Blue/Orange (Pin 54 @ ECU)
Neutral	Tan
Power	Orange
Ground	Black

NOTE: *These wire colors should be correct for most models of Harleys, however it is a good idea to verify locations and colors, check voltages and consulting your service manual before making connections.*

SERVICE AND REPAIR

DAKOTA DIGITAL offers complete service and repair of its product line. In addition, technical consultation is available to help you work through any questions or problems you may be having installing one of our products. Please read through the Troubleshooting Guide. There, you will find the solution to most problems.

Should you ever need to send the unit back for repairs, please call our technical support line, (605) 332-6513, to request a Return Merchandise Authorization number. Package the product in a good quality box along with plenty of packing material. Ship the product by UPS or insured Parcel Post. Be sure to include the RMA number on the package, and include a complete description of the problem with RMA number, your full name and address (street address preferred), and a telephone number where you can be reached during the day. Any returns for warranty work must include a copy of the dated sales receipt from your place of purchase. Send no money. We will bill you after repair.

Dakota Digital 24 Month Warranty

DAKOTA DIGITAL warrants to the ORIGINAL PURCHASER of this product that should it, under normal use and condition, be proven defective in material or workmanship within 24 MONTHS FROM THE DATE OF PURCHASE, such defect(s) will be repaired or replaced at Dakota Digital's option.

This warranty does not cover nor extend to damage to the vehicle's systems, and does not cover removal or reinstallation of the product. This Warranty does not apply to any product or part thereof which in the opinion of the Company has been damaged through alteration, improper installation, mishandling, misuse, neglect, or accident.

This Warranty is in lieu of all other expressed warranties or liabilities. Any implied warranties, including any implied warranty of merchantability, shall be limited to the duration of this written warranty. Any action for breach of any warranty hereunder, including any implied warranty of merchantability, must be brought within a period of 24 months from date of original purchase. No person or representative is authorized to assume, for Dakota Digital, any liability other than expressed herein in connection with the sale of this product.

Dakota Digital

4510 W. 61ST St. N., Sioux Falls, SD 57107
Phone: (605) 332-6513 FAX: (605) 339-4106

www.dakotadigital.com
dakotasupport@dakotadigital.com