

# INSTALLATION INSTRUCTIONS

## COMPU-FIRE® SELECTABLE ELECTRONIC ADVANCE

Big Twin®, Sportster® and Buell® Ignition Modules

for

Nose Cone Applications

THIS INSTRUCTION COVERS THE FOLLOWING:

P/N	DESCRIPTION
20600	1970-1999 Big Twin, Electric Start, exc. Twin Cam
20835	1980-1999 Electric Start, Race, exc. Twin Cam
21835	High Compression Street Big Twins 80-113 ci Electric Start
21835KS	High Compression Street Big Twins 80-113 ci Kick Start
21850	1971 & up Supersport Street Sportster & Buell exc. 1200S.
21860	Supersport Race Sportster & Buell exc. 1200S

### READ THESE INSTRUCTIONS COMPLETELY BEFORE BEGINNING INSTALLATION

**Note:** All electric start motorcycles need a designated ground for starter current, both rubber and solid mount. The battery should be grounded to the frame and from that point on the frame to the starter mounting flange. If this ground is not installed possible damage can occur to the motorcycle electrical systems during starting.

#### Step #1. STOCK IGNITION REMOVAL

**CAUTION:** MAKE SURE IGNITION SWITCH IS OFF AND THE BATTERY GROUND (-) CABLE IS REMOVED FROM THE BATTERY DURING ANY OF THE FOLLOWING PROCEDURES.

#### **CONVERTING POINTS IGNITION TO COMPU-FIRE® ELECTRONIC IGNITION**

Refer to Fig. # 1

1. Remove the optional cover (1), the ignition side cover (2) and gasket (3).
2. Remove the two standoffs (4) and washers (5) that secure the point plate (6) to the ignition housing. Disconnect the wire going to the points and remove the plate assembly.
3. Remove the bolt (7) and the advance assembly (8) and (9) from the engine.

#### **CONVERTING LATE 1978-1979 OEM ELECTRONICS TO COMPU-FIRE® IGNITION**

Refer to Fig.# 2

1. Remove the ignition side cover (10), gasket (11) & ignition module (12). Remove the timer plate (17). Remove hex head bolt (14) and the advance assembly (18) and (19) from the engine.

#### **CONVERTING 1980 and LATER OEM ELECTRONICS TO COMPU-FIRE® IGNITION**

Refer to Fig.# 3.

1. Drill out the rivets (20) in the outer cover (21) and remove the cover.
2. Remove the inner cover (22) and gasket (23).
3. Remove the two standoffs (24). Disconnect the sensor wire connector housing. This allows the terminals to pass through the hole in the ignition housing when the sensor plate is removed.
4. Remove the sensor plate (26).
5. Remove the bolt (27) securing the rotor (28).
6. Remove the rotor (28).

## Step #2. COMPU-FIRE® IGNITION MODULE INSTALLATION

### COMPU-FIRE IGNITION MODULES ARE INSTALLED WITH THE ENGINE AT T.D.C.

Note: **Do not** use the washers Fig.#1 (5), Fig.#2 (16) or Fig. # 3 (25).

1. Clean out the ignition cavity in the cam cover. Replace oil seal if necessary.
2. Refer to Fig.# 4. Secure Compu-Fire trigger rotor (36) with the socket head screw (34) and flat washer (35) using blue Loc-Tite® to prevent loosening. Align the locating pin with the notch in the cam. Torque screw to 25 inch pounds. Remove the timing plug from the observation hole. Remove the spark plugs. With the transmission in top gear, roll the bike until the front cylinder TDC timing mark (Fig. # 5) is in the center of the hole. See Fig. # 6. Observe the position of the magnets and the locating pin in the trigger rotor. For Big Twins® the locating pin will be positioned at 7 o'clock as shown in Fig. #6A or Fig. # 6B. **Fig. # 6A is the correct position.** If the locating pin is in the wrong position (Fig. # 6B), rotate the engine one more revolution which will bring the trigger rotor to the position shown in Fig. # 6A. For Sportster® follow the same procedure using Fig. # 7A and Fig. #7B.

**DO NOT MOVE THE ENGINE POSITION UNTIL THE TIMING PROCEDURE IS COMPLETE.**

3. Install the Compu-Fire ignition module (33) Fig. # 4 using the two standoffs (32) just tight enough so that the module can be rotated to set timing. Locate the module with the V-notch in the module over the V-grooved area in the housing. This groove is at approximately the 7 o'clock position on Big Twins® and the 11 o'clock position on Sportsters®. Refer to Fig. # 8.
4. Carefully thread the cable from the Compu-Fire ignition module through the hole in the housing. Leave enough cable to form a neat loop inside the housing to allow for timing adjustment.

## Step # 3 IGNITION TIMING

Your new Compu-Fire® ignition module has a built in ACCU-RAY timing light and does not require the use of a standard timing light. In fact, a standard timing light is not recommended. Especially a dial-back light as the Harley Davidson® engine fires asymmetrical and will give an incorrect readout

1. With the ignition **switch** in the **off** position reconnect the battery ground cable.
2. Carefully slit the cable jacket about one inch to expose the inner wires. Remove the excess jacket and **strip the red wire only** at this time. Temporally connect the **red wire to battery pos. (+)** being Rotate the ignition module counterclockwise to the full retard position. The ACCU-RAY timing light may be on or off. Use the disk magnet stack supplied in the hardware kit to turn this light on and off to get familiar with it.
3. To do so, place the magnet against the module in the area shown in Fig. # 9. When the side of the magnet with the orange dot is facing you the light will turn off. Turning the magnet over will turn the light on. Leave the light in the off position.
4. Slowly rotate the module clockwise until the ACCU-RAY front cylinder TDC light just turns on. Steps # 3 & 4 may be repeated to insure accurate timing. Tighten standoffs (32) Fig. # 4 at this time.
5. The ignition system is now properly timed.
6. Reinstall the spark plugs.
7. Disconnect the red wire from the battery.
8. Route the cable to the coil(s) making sure it does not touch hot surfaces. Cut the cable to length. Tighten the cable clamp.
9. Carefully slit the cable jacket to expose the inner wires. Remove the excess jacket.
10. Re-install the timing plug into the observation hole.

## Step # 4 WIRING HOOK-UP

**CAUTION:** Incorrect wiring hook-up may damage the COMPU-FIRE® module or other electrical components on the motorcycle.

COMPU-FIRE® ignition modules are compatible with all stock and aftermarket ignition coils with a primary resistance of 2.0 ohms or greater. Coils with higher than 3.0 ohms of primary resistance may be used, however, ignition energy will be greatly reduced. For dual plug applications, use two dual tower coils.

The coil hookup is shown in the following figures:

ALL MODELS	SINGLE PLUG	DUAL PLUG
DUAL FIRE	FIGURE 10	FIGURE 11
SINGLE FIRE	FIGURE 12	FIGURE 13

Note: For tach operation in Single Fire - use Compu-Fire P/N 51105 tach adapter. Dyna tach adapters are not compatible with Compu-Fire modules and must not be used.

### **INITIAL SWITCH SETTINGS**

Set the advance curve switch to position 8 for the correct coil set-up, ie: SINGLE FIRE or DUAL FIRE. Set RPM limiter to position 1 in 50% V.O.E.S. mode.

Compu-Fire Model									
	20600		21835(KS)		21850		21860		
SWITCH	TOTAL		TOTAL		TOTAL		TOTAL		
POSITION	ADV. @ RPM		ADV. @ RPM		ADV. @ RPM		ADV. @ RPM		
1	35°	1500	35°	2500	35°	2500	35°	2500	MOST AGGRESSIVE
2	35°	2000	35°	3000	35°	3000	35°	2500	-----
3	35°	2250	35°	3250	35°	3000	35°	2500	-----
4	35°	2500	32°	3000	32°	2750	35°	2500	-----
5	35°	2750	32°	3250	32°	3250	35°	2500	-----
6	35°	3000	32°	3500	32°	4000	35°	2500	-----
7	35°	3250	30°	3750	30°	5000	35°	2500	-----
8	35°	3500	28°	4000	28°	5000	35°	2500	LEAST AGGRESSIVE

Test ride the bike and note engine operation. **NOTE: WHEN CHANGING SWITCH SETTINGS, THE IGNITION SWITCH MUST BE TURNED OFF.**

Select the next more aggressive curve (switch position 7). Test ride the bike again and note engine operation. If engine knock occurs go back to the previous setting. If engine does not knock, increase maximum advance (see chart) again until pinging occurs. When pinging occurs, switch back to the previous setting.

This is the **IDEAL IGNITION ADVANCE** curve for your bike.

Set the RPM limiter to an appropriate setting for your engine. **NOTE: ONLY MODIFIED ENGINES WITH IMPROVED VALVE TRAIN SHOULD BE OPERATED PAST 6500 RPM.**

### **SELECTING V.O.E.S. MODE**

**Note: The setting of 50% V.O.E.S. is 5° advance and 100% is 10° advance. This is in addition to the regular advance during high intake manifold vacuum at idle or cruise. The total advance will never exceed the total setting of the regular advance curve.**

For Dressers or riding double, position RPM limit switch in 50% V.O.E.S. mode. For lighter bikes, riding solo, and using premium fuel, use the 100% V.O.E.S. mode. If engine knock occurs, reposition RPM limit switch to 50% V.O.E.S. mode or select a less aggressive advance curve. For any combination other than stock the V.O.E.S. should activate at 5" Hg.. **NOTE:** If V.O.E.S. is not used, the RPM limiter will still function. The Green wire from the V.O.E.S. switch must be disconnected and taped off so it does not touch ground.

### **TROUBLE SHOOTING**

To determine if the ignition module is switching properly connect a 12V test light from coil negative (-) to a good ground. Turn the ignition switch on and the light should lite. This tells you that you have voltage available to the coil and that the coil primary winding is not open. Then crank the bike and observe the light. After the first two revolutions the light should flash on and off. This tells you that the ignition module is working properly. On single-fire applications repeat this test for the other cylinder.

**CHECKING for SPARK**

Check for spark to the plug by using a KD tools test plug (or similar) while cranking the bike. If spark is visible, the ignition system is operating.

**PLUG WIRE RECOMMENDATION**

Use a top quality spiral core wire with quality silicone jacket and inner silicone insulation.

**SPARK PLUG RECOMMENDATION**

Due to the special design of the CompuFire® ignition module it is not necessary to run resistor spark plugs. Use a quality brand spark plug gapped at .045" if engine compression and air/fuel combination permits.

**Points Ignition FIG. 1**

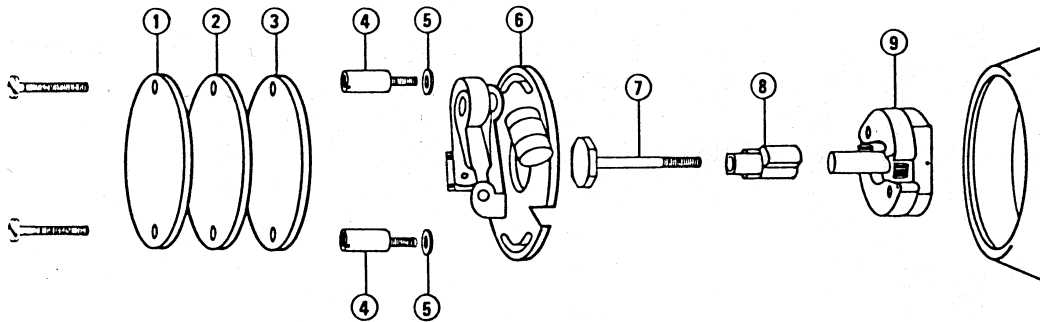

POINTS IGNITION

**Late 1978-1979 OEM Electronics FIG.2**

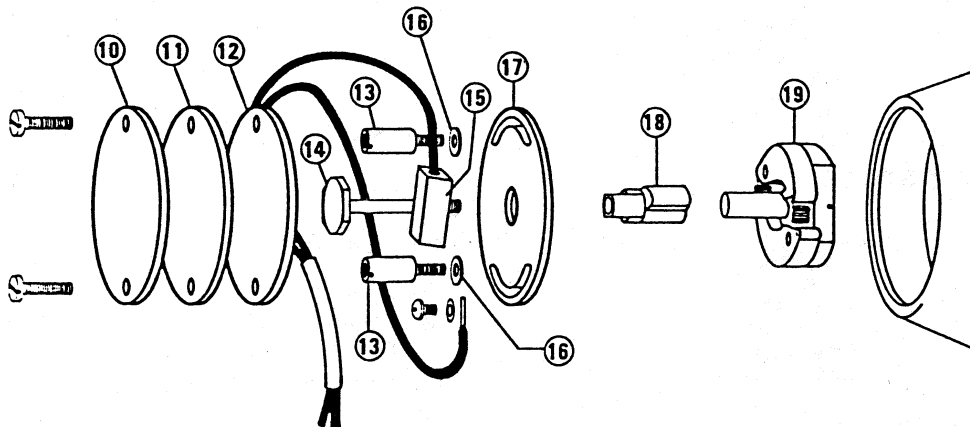

LATE 1978-1979 OEM ELECTRONICS

1980 and Later OEM Electronics **FIG. 3**

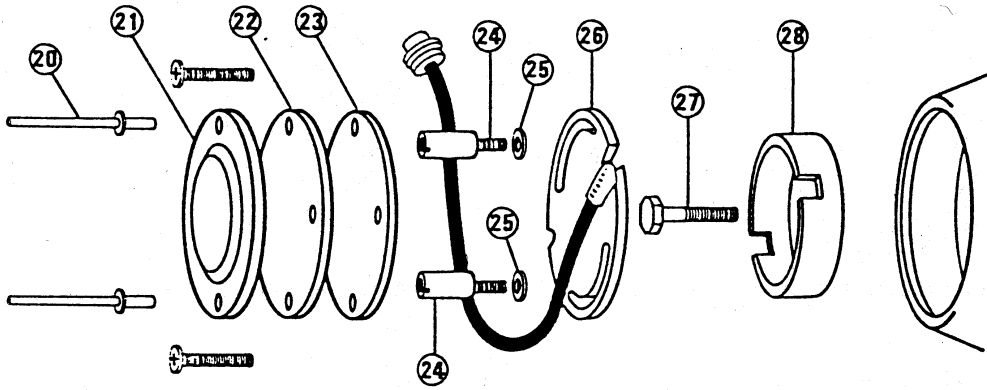

1980 AND LATER OEM ELECTRONICS

**FIG. 4**

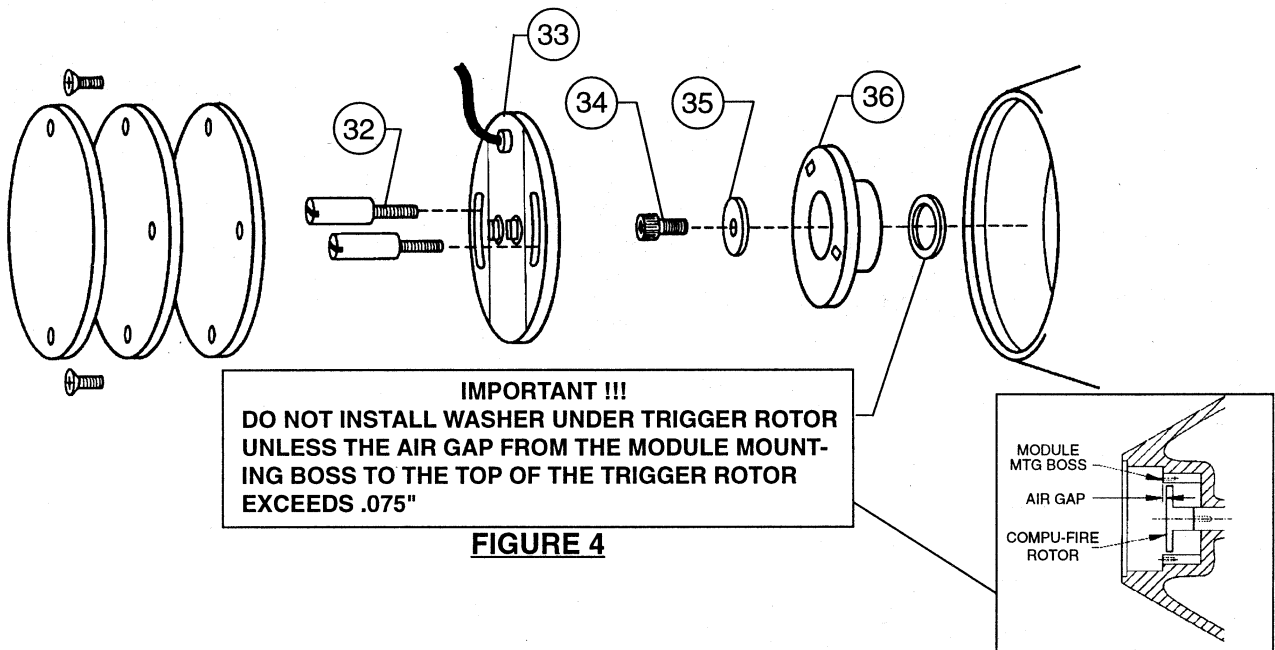

**FIGURE 4**

**FIG. 5**

EARLY STYLE

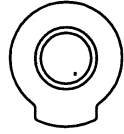

FRONT CYLINDER  
TDC MARK

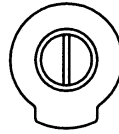

FRONT CYLINDER  
ADVANCE MARK

LATE STYLE

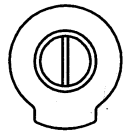

FRONT CYLINDER  
TDC MARK

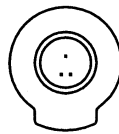

FRONT CYLINDER  
ADVANCE MARK

S & S ENGINES

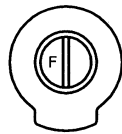

FRONT CYLINDER  
ADVANCE MARK

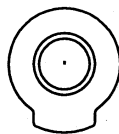

REAR CYLINDER  
ADVANCE MARK

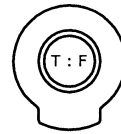

FRONT CYLINDER  
TDC MARK

**FIG. 6**

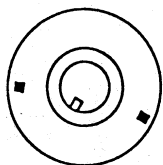

RIGHT WAY  
6A

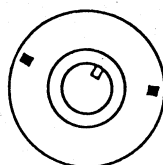

WRONG WAY  
6B

LOCATING PIN POSITION AT T.D.C. FOR BIG TWINS

**FIG. 7**

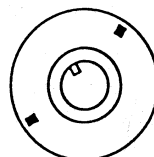

RIGHT WAY  
7A

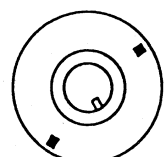

WRONG WAY  
7B

LOCATING PIN POSITION AT T.D.C. FOR SPORTSTERS

**FIG. 8**

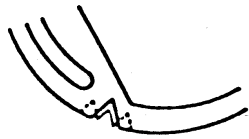

V NOTCH IN 7 O'CLOCK POSITION

**FIG. 9**

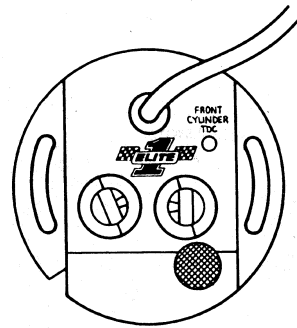

**Dual Fire Single Plug FIG. 10**

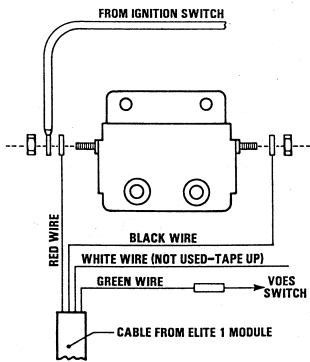

**Dual Fire Dual Plug FIG. 11**

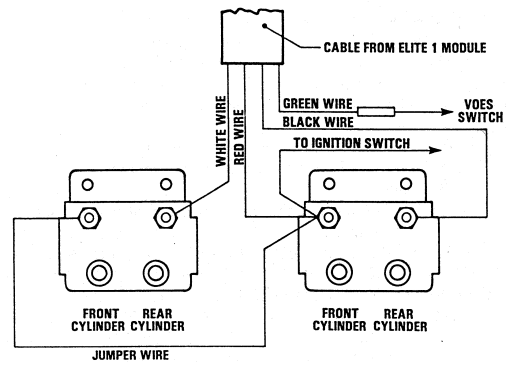

**Single Fire Single Plug FIG. 12**

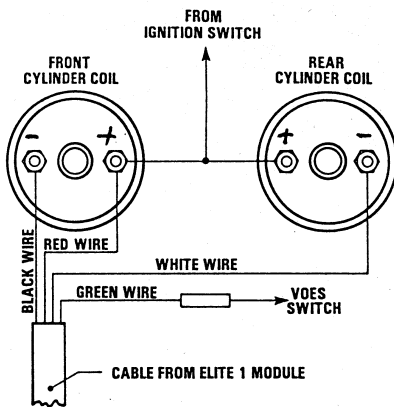

**Crane Single Fire Single Plug FIG. 12**

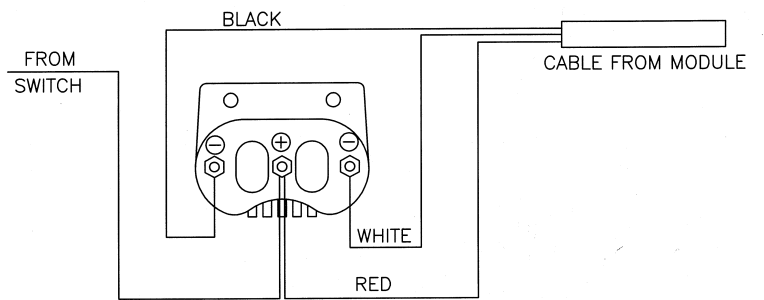

# Single Fire Single Plug **FIG. 13**

