

Installation Instructions Electronic Speedometer dia 48 mm with stepper motor

Dear Customer,
you've made a good selection buying this new **MMB[®]** device. The product should be installed by a person specialising in the installation of such devices.

1. Safety Instructions

To install the electric cables, use existing cable ducts and looms, but do not run the cables parallel to ignition cables or parallel to cables leading to powerful consumers. Secure the cables with cable binders or adhesive tape. When you install the electric cables please also note:

- Do not run the cables over moving parts.
- Ensure that the cables are not exposed to any tensile, compressive or shear forces.
- Use only cable stripper to strip the cables, adjust the cable stripper so that the individual strands are not damaged or cut off.
- Crimped connections should be made only by using a cable crimping pliers.
- Insulate exposed leads in such a way that short circuits cannot occur.

Caution: Risk of short circuits through faulty junctions or damaged cables. Please check all cables and connections for short circuits after you have finished the installation. Short circuits in the electrical system can cause cable fires, battery explosions and damages to other electronic systems. Incorrect connections can lead to short circuits.

Use suitable tools for building in the gauge and note the safety instruction of the tool manufacturers. If you use a reed sensor with magnets, note the safety instructions of the glue manufacturer when installing the magnets.

2. Electric connections

Before starting the electrical installation clamp the battery to disconnect it. Please observe the above mentioned rules of safety.

Connect the individual leads as shown in the sketch.

Use wire with a cross section of approx. 0.5 mm² with PVC-insulation for the connecting cable.

Unused wires have to be isolated. (see safety instructions)

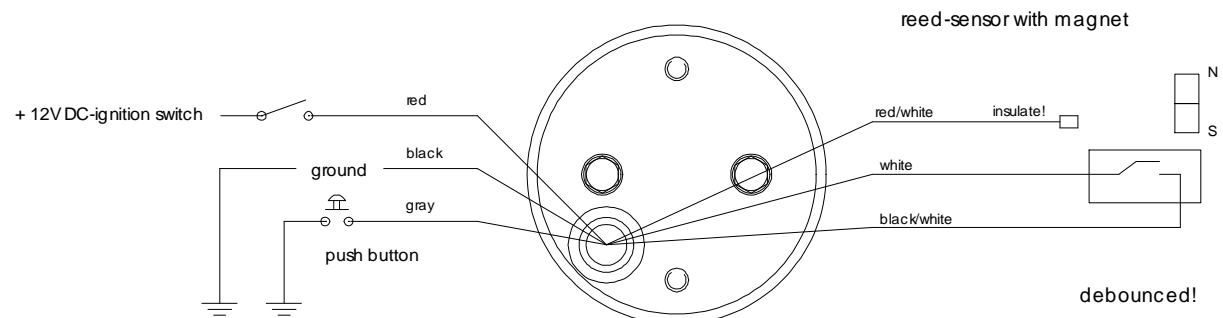
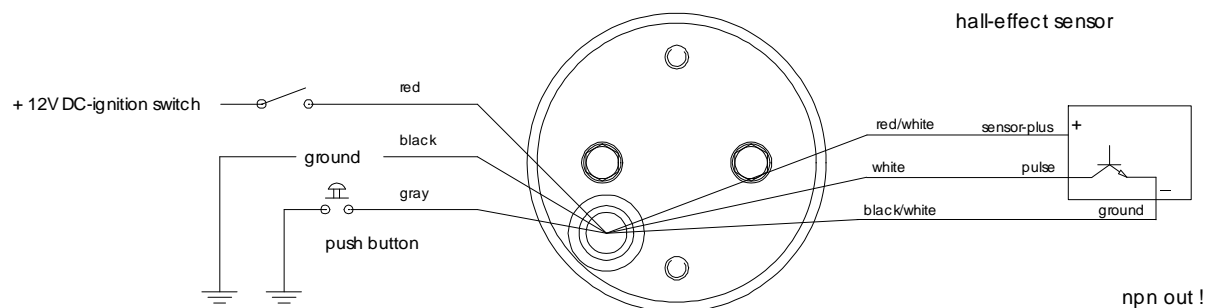

3. Mounting of the speedometer

The speedometer can be mounted into an instrument panel (a recess of $D=48.5 + 0.5$ mm in the instrument panel is required). It can also be mounted on the handlebar with a clamp. Brackets and handlebar clamps are available as accessories.

4. Speed sensor

4.1 Debounced reed sensor with magnets

Available as accessories.

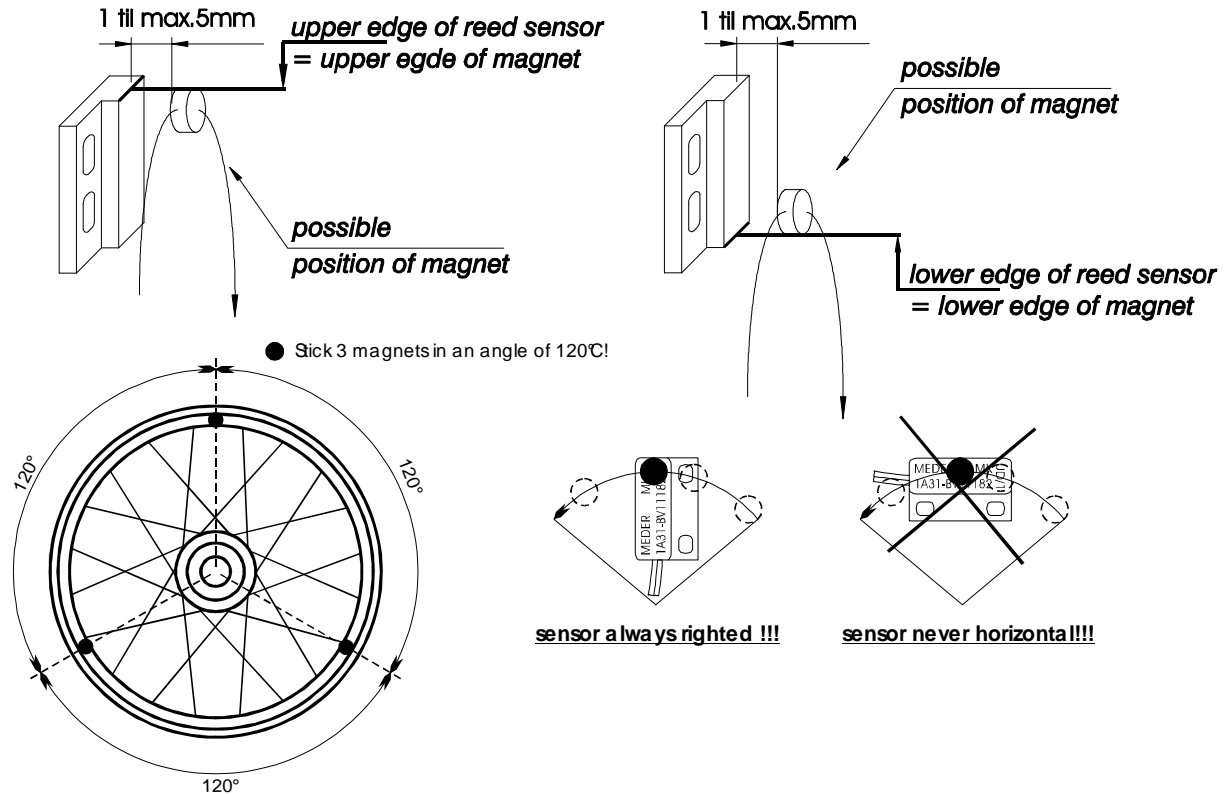

Install the sensor and the magnets according to the sketch. The mentioned dimensions refer to the reed sensor of **MMB[®]**.

Use the enclosed cable fixers to fix the sensor.

Caution: Inside the sensor is a small glass tube, avoid mechanical stress like tension on the sensor when installing it.

If the sensor is used on the rear wheel, the sensor cable should be shielded.

We do not assume any liabilities for damages or indirect damages!

Stick 2 magnets in an angle of 180° or 3 magnets in an angle of 120° in the near of the hub (to minimize the centrifugal force) on a plane, clean and greaseless surface.

Please use appropriate glue. As additional security an elastic silicone film should be laid around the magnets.

If you have lost a magnet, the speedometer will indicate the wrong speed (too little)!

Caution: Risk of a speed fine!

4.2 Hall effect sensor

requirements of the hall sensor

- must have a npn-output
- operating voltage approx. $U = 12 \text{ V dc}$

4.3 Calculation of the Pulses-per-Kilometer (N)

For calculation of the pulses-per-kilometer the following specifications are required:

- rolling circumference of the wheel (where the magnets are situated)
- number of pulses per wheel rotation

Use the following formula:

For a km/h scale:

$$N = \frac{1000 \text{ [meters]}}{\text{rolling circumference [meters]}} \times \text{number of pulses per wheel rotation}$$

For a mph scale:

1 Mile = 1609 meters

$$N = \frac{1609 \text{ [meters]}}{\text{rolling circumference [meters]}} \times \text{number of pulses per wheel rotation}$$

Insert the calculated pulses-per-kilometer (or pulses per mile) in the speedometer to calibrate it. (see "Calibration mode" in the instruction)

4.3.1 Calculation of pulses-per-kilometer for Harley Davidson[®] with OEM speed sensor required specifications

- rolling circumference of the rear wheel
- number of teeth of the secondary transmission (rear wheel pulley / trans pulley)
- number of teeth of one of the gears on the mainshaft

Calculation (for speedometer with km/h scale)

$$N = \frac{1000 \text{ m}}{U} \times S \times Z \quad \text{or} \quad N = \frac{1000 \text{ m}}{U} \times I$$

U: rolling circumference [in m]

S: secondary transmission= teeth of sprocket wheel / teeth of (gearbox output-) pinion

Z: number of teeth of one of the gears

I: number of sensor pulses per rear wheel rotation

N: Pulses per Kilometer

Example for Harley Davidson[®] with 883 ccm Evolution V-Twin Motor

→ all 2003 Sportster models

XHL Sportster 883

XHL Sportster 883 Hugger

XL Sportster 883

XL 53C Sportster Custom 53

rear tire: 130 / 90 B16

→ rolling circumference $u = 1933 \text{ mm} = 1.933 \text{ m}$

secondary transmission:

number of teeth sprocket wheel / pinion $z_1/z_2 = 61/27$

number of teeth of the 5th gear on the mainshaft: $z_5 = 42$

Calculation for speedometer with **km/h scale**:

$$N = (1000 \text{ m} / 1.933 \text{ m}) \times (61/27) \times 42 = 49089 \text{ [Pulses per Kilometer]}$$

Calculation for speedometer with **mile scale**:

$$N = (1609 \text{ m} / 1.933 \text{ m}) \times (61/27) \times 42 = 78984 \text{ [Pulses per Mile]} \quad 1 \text{ Mile} = 1609 \text{ meters}$$

5. Accessories (not included)

You find suitable accessories like:

Sensors

Magnets

Glue

Push buttons

Brackets and clamps

in our Webshop.

Electronic Speedometer dia 48 mm Calibration and Operation Instructions

1. General information

The speedometer is calibrated and operated by a push button.

The push button can be pushed shortly (< 1 second) or long (approx. 1 second).

2. Calibration mode

The calibration can be accomplished in two ways:

- "PULS" – Mode: By input of a known pulse-per-kilometer (or pulse-per-mile, if the speedometer has a mph-scale)
- "Auto"– Mode: Automatic calibration when driving on a road with the exact distance of 1 kilometer (if you have a kilometer scale) or 1 mile (if you have a mile scale) clearly defined.

Please note, that the Pulse-per-kilometer/mile must have a minimum value of 1000.

To get into the calibration mode, please push the button while turning on the ignition.

push the button
while switching on ignition

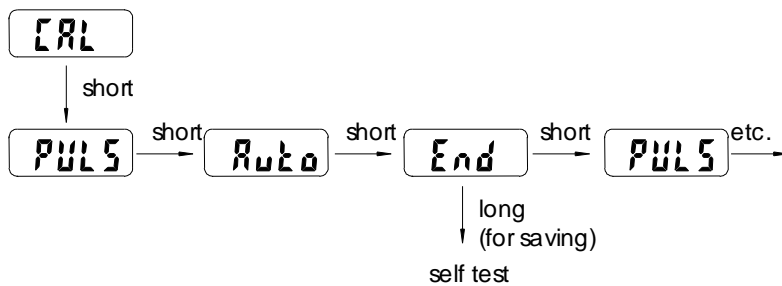

2.1 Manual calibration

push the button
while switching on ignition

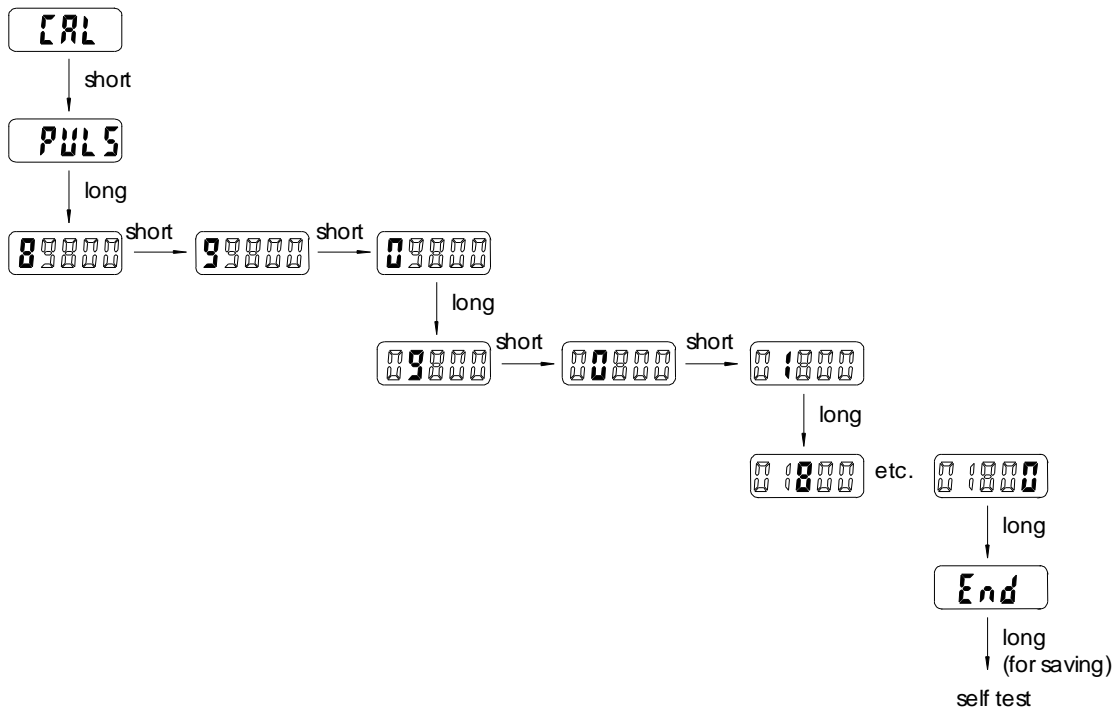

If you entered a wrong value unintentionally, you can cancel the calibration anytime by turning of the ignition.

2.2 Automatic calibration

It is also possible to calibrate the speedometer automatically by driving on a road with the exact distance of 1 mile (if you have a mile scale) or 1 kilometer (if you have a kilometer scale) clearly defined.

Please note during the automatic calibration, there is indication of speed!

push the button
while switching on ignition

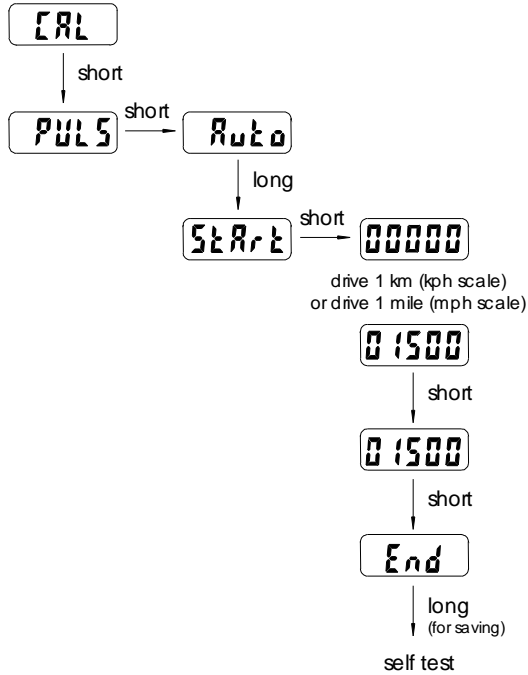

3. Operating of the Speedometer

When turning on the ignition, the speedometer checks his functions itself (full-scale deflection of the pointer). During the upward movement of the pointer all segments of the LCD flash at the same time, during the downward movement the serial number of the speedometer is indicated.



After the self test the display shows the chosen menu.

3.1 Display functions

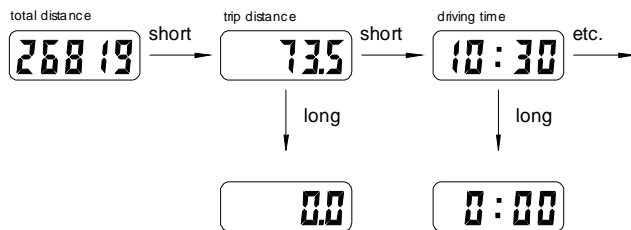

Total distance GW

- 0...99999 km (or miles)
- can not be reset

Trip distance

0.0...9999.9 km (or miles)

can be reset by pushing the button long (reset will be saved after driving approx. 100 metres)

Driving time

0:00....23:59 h

can be reset by pushing the button long, or will be reset automatically when turning off ignition

4. Technical Data

rated voltage:	12VDC, the negative pole of the battery has to be grounded
voltage range:	10.8 V – 15 V
max. current consumption:	< 100 mA during driving (depends on display color)
operating temperature	-20 - +85 °C
diameter of the instrument:	48 mm
instrument height:	58 mm
Impulse range	1000 Impulses / Kilometer – 99999 Impulses / Kilometer or 1000 Impulses / Mile – 99999 Impulses / Mile
data back-up	without current at least 10 years

5. Warranty notice

Our products are manufactured with utmost care and they are in accordance with the relevant DIN-Standards (German Industrial Standards).

Pulsotronic GmbH & Co. KG is not liable for damages arising from improper handling.

In case of necessity, please contact our service and we are always ready to help you.

Telephone: +49 (0) 37296 930 250
Fax: +49 (0) 37296 930 258
Email: info@mmb-messtechnik.de

Your team at Pulsotronic GmbH & Co. KG, MMB-Messtechnik, Germany

Necessary Information in case of warranty:

Name:

Address:

Tel.:

Fax:

Email:

Serial no. of speedometer:	
Description of defect:	
Used speed sensor:	
Motorcycle:	
Model:	
Model year:	