

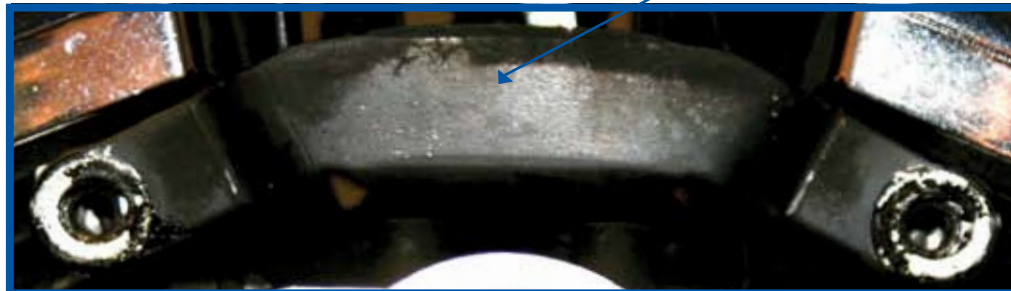

## SUPER GAS AIR CLEANER



REUSE THROTTLE BODY SUPPORT **FIG. A**



**Note:** On fuel injected models recalibration of the ECM is required for optimum performance. Use the Vance & Hines fuelpak or equivalent programmer.

**Note:** On 1993-1999 HD Evolution applications breather bolt thread adapters are required (11). To install thread a 3/8-16 Hex bolt through the insert and install into the breather hole. Once the insert is completely installed remove the 3/8" bolt and begin air cleaner installation.

**Note:** Use blue Loctite on all fasteners during assembly.

1. Turn off motorcycle, extinguish all cigarettes and open flames, place motorcycle securely on the side stand or lift.
2. Remove the existing air cleaner. (Refer to the HD service manual if necessary).
3. Install the breather standoffs(6) and backing plate(4) using the supplied breather bolts(8). Leave bolts loose.
4. Attach the backing plate to the carburetor or throttle body using the three 1/4-20 bolts(1).
5. Torque breather bolts to 15 ft-lbs and the 1/4-20 bolts to 8 ft-lbs.

**Note:** On 2008 & 2009 FL model with electronic throttle reuse the throttle body support bracket as shown in Figure A.

**Note:** Use the stock throttle body/Carburetor gasket on all models.

6. Install rubber breather tubes (except on Sportster Models) as shown in Figure B (page 2).
7. Install the o-ring(17) into the universal outer ring(9) groove. Tip: Use a few dabs of grease to keep the o-ring from falling out of the groove.
8. Using the 1/4-20 flat head bolt(19), beauty washer(18), and 1/4-20 nylock nut(15) assemble the mesh insert, foam spacer, and air filter into a subassembly.
9. Install the secondary plate(5), air filter(3) subassembly (from step 8), foam ring(14), mesh insert(7), plastic spacer ring(16), and universal outer ring as an assembly.
10. Using the supplied 1/4-20 x 2.5" bolts(2) and spacers(10) secure the air filter assembly. Torque the bolts to 8 ft-lbs.

**Note:** If customer has purchased the PM design matched faceplate remove and discard the plastic spacer ring(16). The design matched faceplate replaces this spacer. Other components that will be removed are the beauty washer(18), 1/4-20 flat head cap screw(19), and 1/4-20 nylock nut(15).

11. Install the PM adhesive backed logo badge. PM has supplied 3 badges, one black, one silver, and one with a center hole. Apply the badge with the center hole when assembling the universal air cleaner without the design matched faceplate. When installing the design matched faceplate chose between the black or silver PM logo badge.
12. Recalibrate your ECM to the supplied values from your exhaust manufacturer. PM recommends upgrading your exhaust to optimize your motorcycles performance.
13. Fire up your "Performance Machine" and hit the road.

**CAUTION !!! - INTENDED FOR OFF HIGHWAY USE ONLY. DOES NOT COMPLY WITH EMISSIONS REGULATIONS**



FIG. B



## SUPER GAS AIR CLEANER

Fits 1992 - 2006 BigTwins with CV Carbs  
 Fits 2000 - 2007 EFI Model Big Twins  
 0206-2006-CH  
 0206-2006-BM  
 Fits 2008 FL Models w/ Electronic Throttle  
 0206-2007-CH  
 0206-2007-BM  
 Fits 1998-2008 Sportster XL Models  
 0206-2008-CH  
 0206-2008-BM

FIG. C

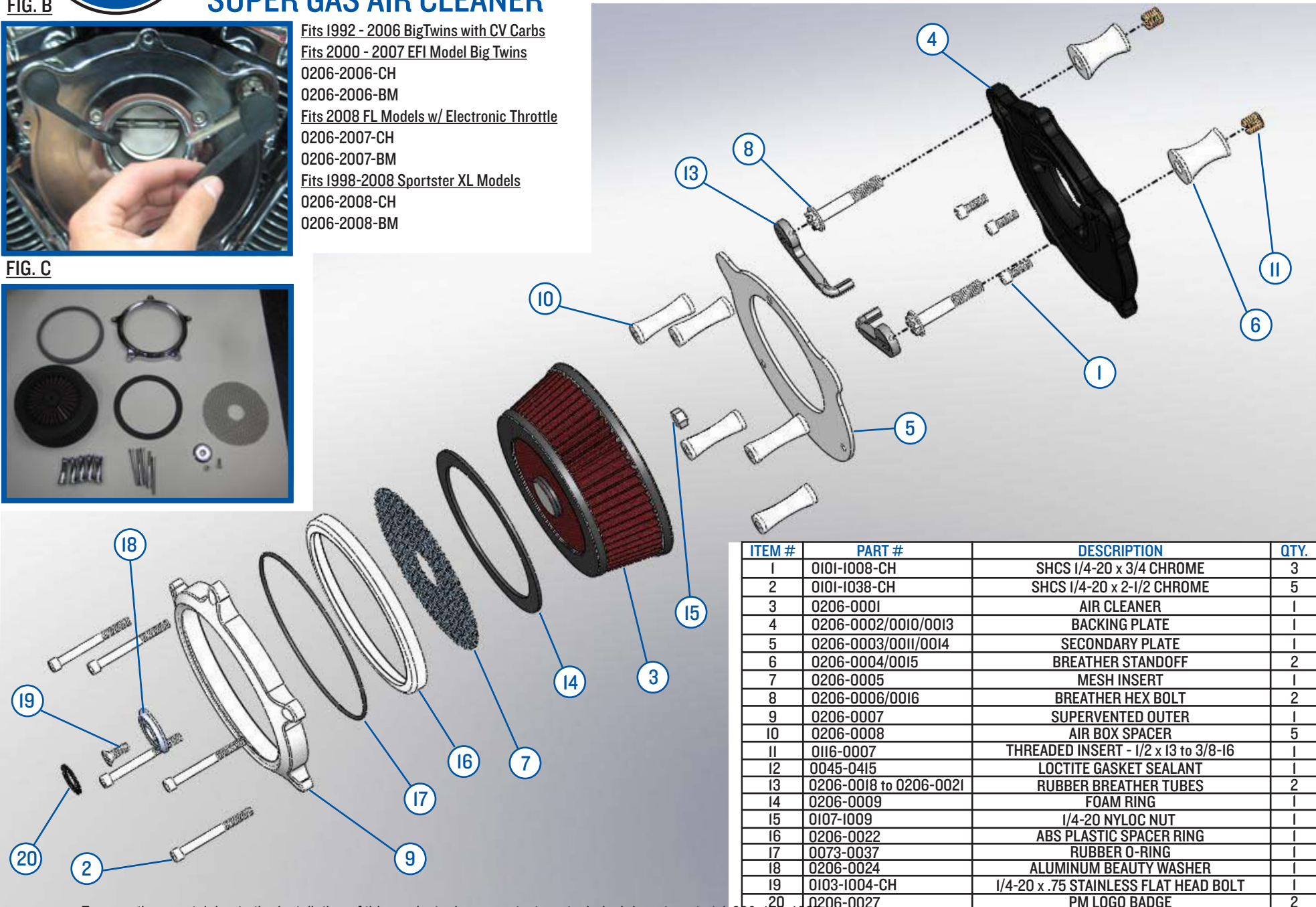

ITEM #	PART #	DESCRIPTION	QTY.
1	0101-1008-CH	SHCS 1/4-20 x 3/4 CHROME	3
2	0101-1038-CH	SHCS 1/4-20 x 2-1/2 CHROME	5
3	0206-0001	AIR CLEANER	1
4	0206-0002/0010/0013	BACKING PLATE	1
5	0206-0003/0011/0014	SECONDARY PLATE	1
6	0206-0004/0015	BREATHER STANDOFF	2
7	0206-0005	MESH INSERT	1
8	0206-0006/0016	BREATHER HEX BOLT	2
9	0206-0007	SUPERVENTED OUTER	1
10	0206-0008	AIR BOX SPACER	5
11	0116-0007	THREADED INSERT - 1/2 x 13 to 3/8-16	1
12	0045-0415	LOCTITE GASKET SEALANT	1
13	0206-0018 to 0206-0021	RUBBER BREATHER TUBES	2
14	0206-0009	FOAM RING	1
15	0107-1009	1/4-20 NYLOC NUT	1
16	0206-0022	ABS PLASTIC SPACER RING	1
17	0073-0037	RUBBER O-RING	1
18	0206-0024	ALUMINUM BEAUTY WASHER	1
19	0103-1004-CH	1/4-20 x .75 STAINLESS FLAT HEAD BOLT	1
20	0206-0027	PM LOGO BADGE	2