



PM MaxHP AIR CLEANER



PERFORMANCE MACHINE LIMITED WARRANTY INFORMATION

Performance Machine warrants to the original purchaser that the parts of this air filter assembly to be free of manufacturing defects in materials and workmanship for a period of one (1) year from the date of purchase. In the event warranty service is required, you must call Performance Machine immediately with a description of the problem.

If it is deemed necessary for Performance Machine to make an evaluation to determine whether the part is defective, a return authorization number will be given by Performance machine. The parts must be packaged properly so as to not cause further damage and returned prepaid to Performance Machine with a copy of the original invoice of purchase and a detailed letter outlining the nature of the problem. If after the evaluation by Performance Machine the part was found to be defective it will be repaired or replaced at no cost to you. If we replace it, we may replace it with a reconditioned one of the same design.

Performance Machine shall not be held liable for any consequential or incidental damages resulting from the failure of a Performance Machine part.

Performance Machine shall have no obligation if a part becomes defective as a result of improper installation or abuse.

IMPORTANT NOTICE

Before installing this air filter system, read through these instructions completely; this will familiarize you with the way in which the parts fit together and the tools needed to complete the job.

The PM MaxHP Air Cleaner involves alterations to your motorcycle and may void your factory warranty. PM STRONGLY recommends this installation be done by an experienced motorcycle mechanic.

DISCLAIMER

These Performance Machine parts are designed for high performance motorcycle applications and are intended for the very experienced rider only. The installation of these Performance Machine parts may adversely effect or void your factory warranty.

Note: The PM MaxHP Air Cleaner is street legal in most states but is not legal for sale or use on pollution controlled vehicles in California or states adopting California emissions standards.

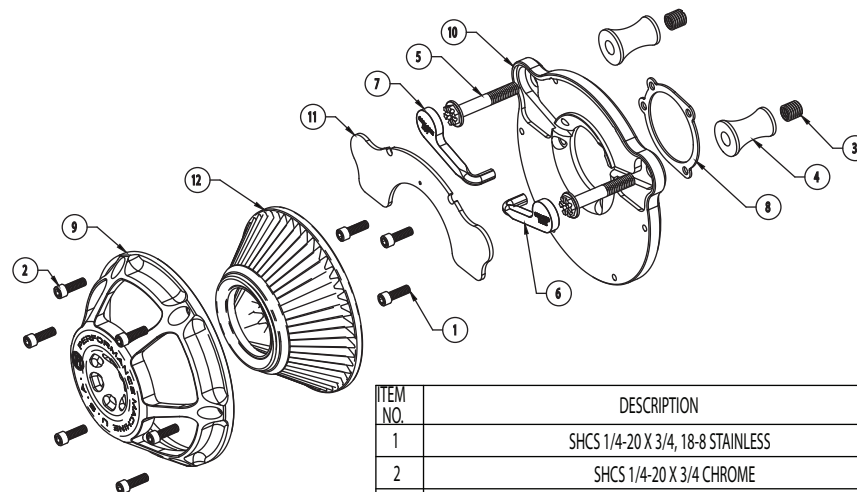

ITEM NO.	DESCRIPTION	QTY.
1	SHCS 1/4-20 X 3/4, 18-8 STAINLESS	3
2	SHCS 1/4-20 X 3/4 CHROME	6
3	THREADED INSERT, 3/8-16 TO 1/2-13; ONLY 0206-2078	2
4	BREATHER STANDOFF; VENTURI AIR CLEANER	2
5	BREATHER HEX BOLT	2
6	OIL TUBE - RIGHT	1
7	OIL TUBE - LEFT	1
8	GASKET	1
9	OUTER, PM MAXHP AIR CLEANER COVER	1
10	PM MAXHP BACKING PLATE	1
11	SECONDARY PLATE, PM MAXHP AIR CLEANER	1
12	AIR FILTER, MAXHP AIR CLEANER	1



PERFORMANCE MACHINE MaxHP AIR CLEANER INSTALLATION

1. Turn off your motorcycle and disconnect the battery.

2. Remove existing air cleaner assembly.

(Refer to your HD service manual for additional instructions)

3. Install carburetor/throttle body gasket(8), breather spacers(4), and main backing plate (10) using supplied breather bolts(5). Leave bolts loose.

Note 1: On pre-1999 Evolution engines install the threaded inserts (3) into the cylinder heads using a 3/8-16 bolt.

Note 2: On 2008-up FL models reuse the throttle body support bracket shown below.

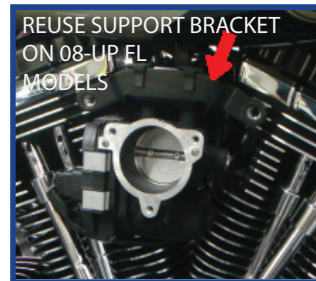

4. Next attach the backing plate(10) to the carburetor/throttle body using the supplied 1/4"-20 x 3/4" socket head bolts(1) and tighten to 8 ft-lbs. Torque breather bolts to 15 ft-lbs.

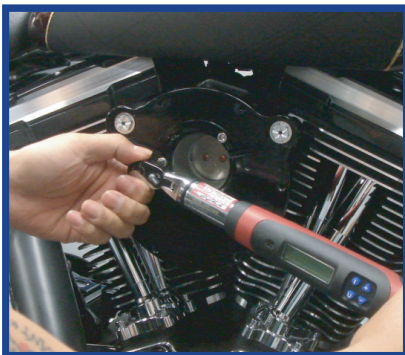

5. Install rubber oil tubes (6 & 7) into the corresponding grooves in the backing plate.



6. Install the secondary plate (11). Install the filter (12) and outer cover (9) at the same time using one 1/4"-3/4" Cap screw (2) to hold the assembly in place. Make sure the round PM logo is clocked to the 9 o'clock position and install the remaining bolts and torque the bolts to 8 ft-lbs.

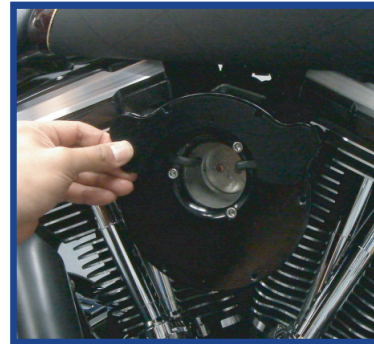

8. Reconnect the battery and go for a ride!

Disclaimer: Tuning the carburetor or fuel injection system may be required for optimum performance.

CONTACT INFORMATION

Performance Machine
6892 Marlin Circle
La Palma, California
90623 - USA

Toll Free: 800-479-4037

Direct: 714-523-3000

Fax: 714-523-3007

Email: tech@performancemachine.com

Website: performancemachine.com