



## IMPORTANT NOTICE

Before installing this air filter system, read through these instructions completely; this will familiarize you with the way in which the parts fit together and the tools needed to complete the job.

The PM Fastair Intake Solution involves alterations to your motorcycle and may void your factory warranty. PM **STRONGLY** recommends this installation be done by an experienced motorcycle mechanic.

## DISCLAIMER

These Performance Machine parts are designed for high performance motorcycle applications and are intended for the very experienced rider only. The installation of these Performance Machine parts may adversely effect or void your factory warranty.

**Note:** The PM FastAir Intake Solution is street legal in most states but is not legal for sale or use on pollution controlled vehicles in California or states adopting California emissions standards.

## PERFORMANCE MACHINE LIMITED WARRANTY INFORMATION

Performance Machine warrants to the original purchaser that the parts of this air filter assembly to be free of manufacturing defects in materials and workmanship for a period of one (1) year from the date of purchase. In the event warranty service is required, you must call Performance Machine immediately with a description of the problem.

If it is deemed necessary for Performance Machine to make an evaluation to determine whether the part is defective, a return authorization number will be given by Performance machine. The parts must be packaged properly so as to not cause further damage and returned prepaid to Performance Machine with a copy of the original invoice of purchase and a detailed letter outlining the nature of the problem. If after the evaluation by Performance Machine the part was found to be defective it will be repaired or replaced at no cost to you. If we replace it, we may replace it with a reconditioned one of the same design.

Performance Machine shall not be held liable for any consequential or incidental damages resulting from the failure of a Performance Machine part.

Performance Machine shall have no obligation if a part becomes defective as a result of improper installation or abuse.

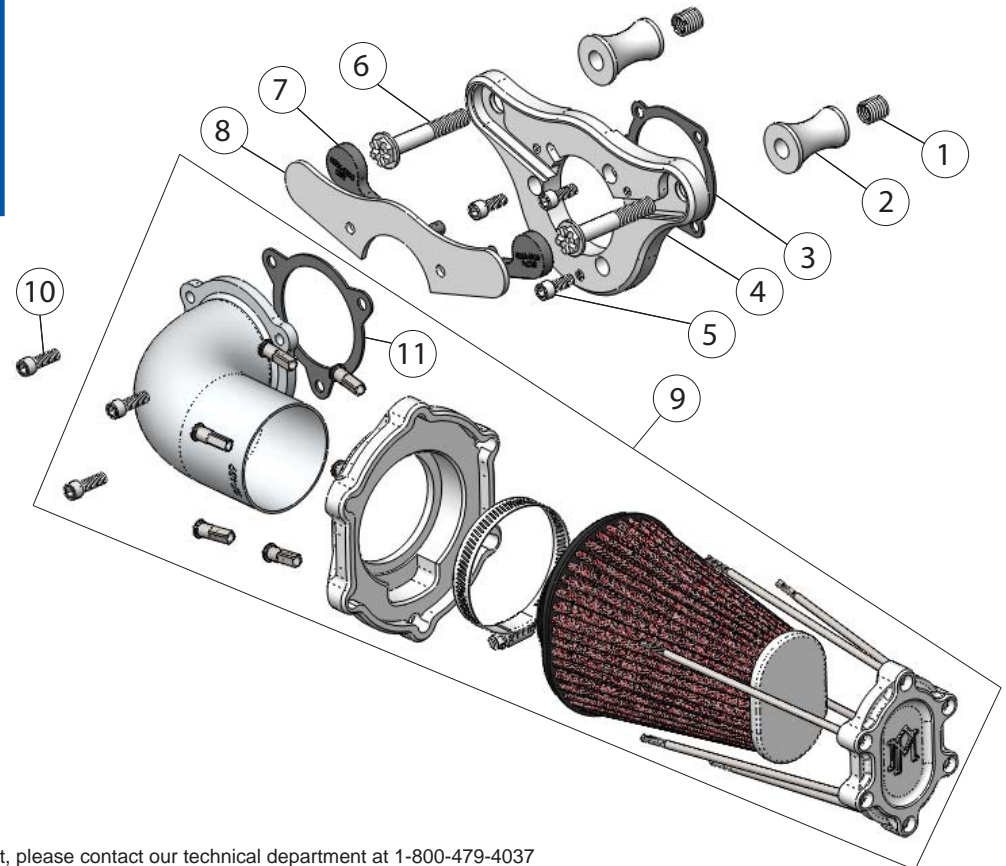



### PERFORMANCE MACHINE FASTAIR INTAKE SOLUTION INSTALLATION

1. Turn off your motorcycle and disconnect the battery.

2. Remove existing air cleaner assembly.

(Refer to your HD service manual for additional instructions)

3. Install carburetor/throttle body gasket(3), breather spacers(2), and main backing plate (4) using supplied breather bolts(6). Leave bolts loose.

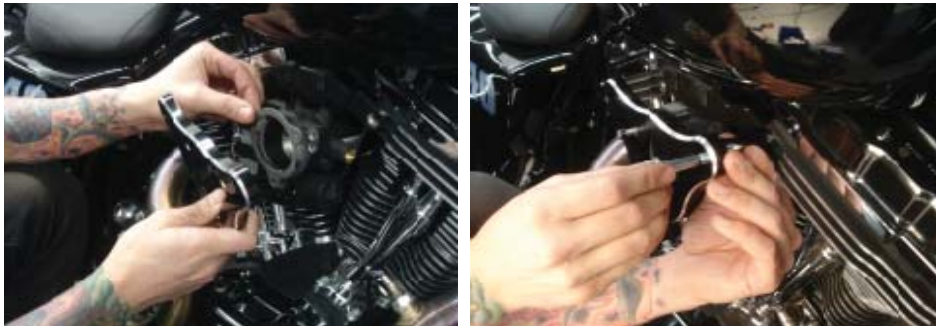

4. On Big Twin & Sportster models attach the backing plate(4) to the carburetor/throttle body using the supplied 1/4"-20 x 5/8" socket head bolts(5) and tighten to 8 ft-lbs. On 2008-up FL touring models with electronic throttle locate the backing plate(4) to the throttle body using the supplied 1/4"-20 x 1-1/4" socket head screws. Do not tighten during this step.



5. Torque breather bolts(6) to 15 ft-lbs. 6. Install rubber oil tubes. **Note: Oil tubes are not used on Sportster models**



7. On Big Twin & Sportster models using the supplied 1/4"-20 x 3/4" socket head bolts(10) install the secondary plate(8), gasket(11), and complete filter assembly(9) and torque to 8 ft-lbs. On 2008-up FL models with electronic throttle install the secondary plate(8), gasket(11), and complete filter assembly(9) using the 1/4"-20 x 1-1/4" socket head screws and torque to 8 ft-lbs.



8. Reconnect the battery and go for a ride!

#### CONTACT INFORMATION

Performance Machine  
6892 Marlin Circle  
La Palma, California  
90623 - USA

Toll Free: 800-479-4037

Direct: 714-523-3000

Fax: 714-523-3007

Email: [tech@performancemachine.com](mailto:tech@performancemachine.com)

Website: [performancemachine.com](http://performancemachine.com)





### FILTER CLEANING INSTRUCTIONS

The Performance Machine Fastair Intake Solution utilizes a high performance K&N filter unit which can be cleaned and reused. The filter element can easily be removed with a basic flathead screwdriver. Take precautions to protect the finishes of the aluminum pieces during removal.

1. Remove the 6 stainless steel spoke nipples (13) and slide the spokes (17) and front aluminum cap (18) from the filter.



2. Slide the aluminum rear filter cover (14) off the filter onto the 90 degree tube (12) to expose the hose clamp (15). **Tip: Place masking tape around the 90 degree tube (12) to protect the finish from damage!** Loosen the hose clamp to free the filter element (16).



3. With the filter removed, clean according to K&N's filter cleaning instructions which are included in the filter care service kit. K&N's filter care service kit can be purchased from K&N directly or almost any automotive parts store. Go to [www.kandn.com/cleaning.htm](http://www.kandn.com/cleaning.htm) for cleaning instructions.

4. Once the filter is clean, reinstall the rear filter cover (14), hose clamp (15), and filter element (16) onto the 90 degree tube (12). Make sure to clock the hose clamp to the 6 o'clock position as shown in the diagram to ensure proper alignment, then tighten the hose clamp snugly until you can't spin the filter on the 90 degree tube.

5. Place the front filter cover (18) onto the filter and reinstall the spokes (17) and nipples (13) one at a time. Thread the nipples onto the spokes carefully and leave loose until all 6 are installed. Once they are all installed, use the screwdriver to tighten each nipple in a circular pattern around the filter.

**Important: Do not overtighten the nipples to avoid deforming the filter.**

