



INSTALLATION GUIDE

PART: 1311-0103

LEGEND AERO-A™

WWW.LEGENDSUSPENSIONS.COM

FITMENT:

1999+ HARLEY-DAVIDSON
FLH TOURING MODELS

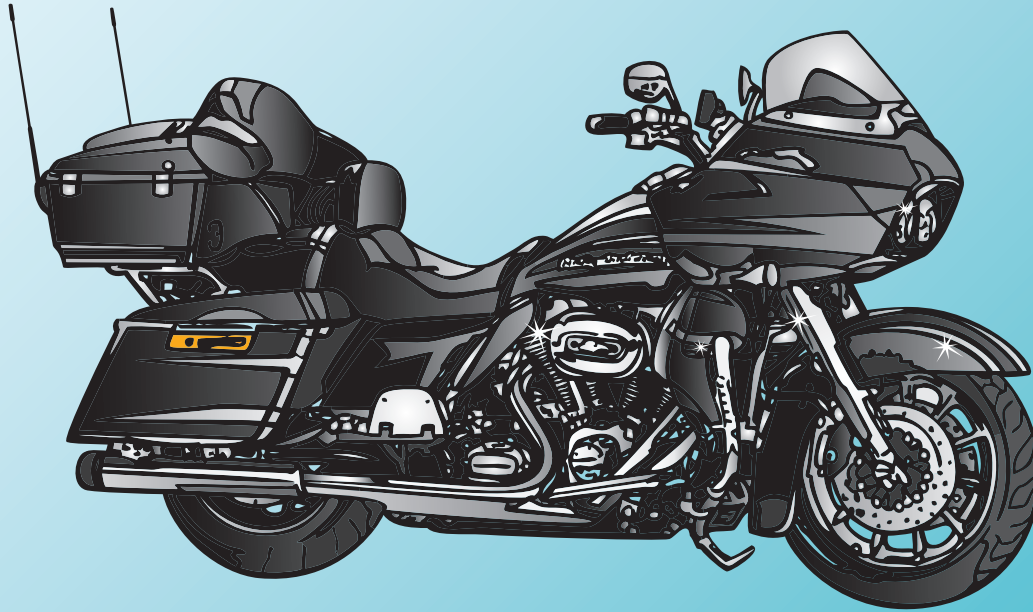

WARRANTY

All Legend Suspension System™ parts are guaranteed to the original purchaser to be free of manufacturing defects and workmanship. Merchandise that fails to conform to these conditions will be repaired or replaced at Legend Suspension Systems™ option if the parts are returned to us by the purchaser. Warranty coverage is limited lifetime.

In the event warranty service is required, the original purchaser must call or e-mail Legend Suspension Systems™ immediately with the problem. Some problems can be rectified by a telephone call and need no further course of action.

A part that is suspect of being defective must not be replaced by a Dealer without prior authorization from Legend Suspension Systems™. If it is deemed necessary for Legend Suspension Systems™ to make an evaluation to determine whether the part was defective, a return authorization number must be obtained from Legend Suspension Systems™. The parts must be packaged properly so as to not cause further damage and be returned prepaid to Legend Suspension Systems™ with a copy of the original invoice of purchase. If after an evaluation has been made by Legend Suspension Systems™ and the part was found to be defective, repair will be made at Legend Suspension Systems™ discretion.

ADDITIONAL WARRANTY PROVISIONS

- (1) Legend Suspension Systems™ shall have no obligation in the event a Legend Suspension Systems™ part is modified by any other person or organization.
- (2) Legend Suspension Systems™ shall have no obligation if a Legend Suspension Systems™ part becomes defective in whole or in part as a result of improper installation, improper maintenance, improper use, abnormal operation, or any other misuse or mistreatment of the Legend Suspension Systems™ part.
- (3) Legend Suspension Systems™ shall not be liable for any consequential or incidental damages resulting from the failure of a Legend Suspension Systems™ part, the breach of any warranties, the failure to deliver, delay in delivery in non-conforming condition, or for any other breach of contract of duty between Legend Suspension Systems™ and a customer.
- (4) Legend Suspension Systems™ shall have no warranty or liability obligation if a Legend Suspension Systems™ part is used in any other application. Vehicles used in competition or off road are exempt from all warranties.
- (5) All warranty items will require the original purchase invoice.

Legend Suspension Systems™ assumes no responsibility for damage or injuries which may result from the use or installation of its products, whether or not properly installed or used. All parts sold or manufactured by Legend Suspension Systems™ are warranted against all manufacture defects or workmanship defects. Should a product we manufacture be defective, it must be returned to Legend Suspension Systems™. All returns must be authorized in advance with RA#. Freight must be prepaid by customer. If our product is found to be defective, it will be repaired free of charge or exchanged at Legend Suspension Systems™ discretion. Repairs or exchanges will not be issued if merchandise has been damaged, abused or modified. Any disagreement which may arise out of this agreement shall be submitted to arbitration and shall be enforceable under the laws of the State of South Dakota. Judgement on the award shall be entered into by the said court, and the decision of the arbitrator shall be a condition precedent to legal rights. The parties shall submit disputed matters under the Rules of the American Arbitration Association and the losing party shall pay both parties' attorneys' fees and costs.





1

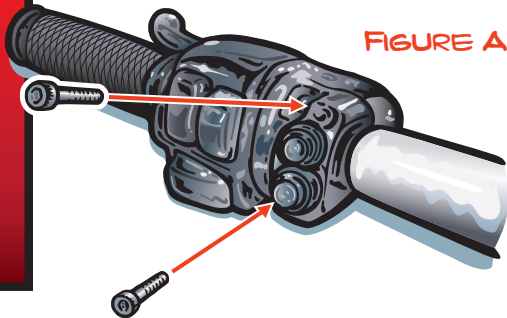
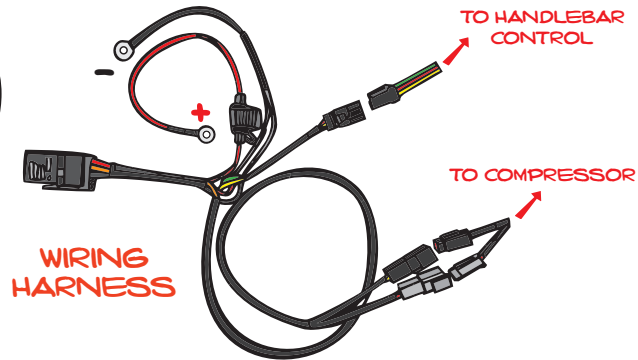

FIGURE A

2



WIRING HARNESS

STEP ONE: HANDLEBAR CONTROL

- REMOVE OE CLUTCH CLAMP.
- RE-USING OE HARDWARE, INSTALL LEGEND HANDLEBAR CONTROL AS SHOWN IN **FIGURE A**.
- ROUTE CABLE DOWN THE HANDLEBARS AND UNDER THE GAS TANK TO THE BATTERY COMPARTMENT.
- SECURE CABLE USING CABLE-TIES.

STEP TWO: WIRING HARNESS

- REMOVE THE FUSE FROM THE FUSE HOLDER.
- CONNECT THE HANDLEBAR CONTROL CONNECTOR TO THE MATING CONNECTOR ON THE WIRING HARNESS.
- CONNECT RED WIRE TO POSITIVE TERMINAL AND BLACK WIRE TO NEGATIVE TERMINAL ON BATTERY.
- FROM THE BATTERY COMPARTMENT ROUTE THE COMPRESSOR END (GRAY & BLACK CONNECTORS) OF THE HARNESS TO THE COMPRESSOR LOCATION UNDERNEATH THE BIKE SHOWN IN **FIGURE B**. FOLLOW THE MAIN WIRING HARNESS ALONG THE FRAME RAIL

3

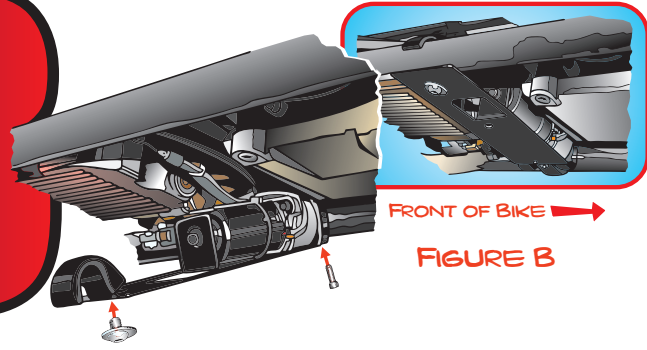

FIGURE B

STEP THREE: COMPRESSOR MOUNT

- CONNECT THE GRAY AND BLACK CONNECTORS FROM THE WIRING HARNESS TO THE MATCHING COLOR CONNECTORS ON THE COMPRESSOR ASSEMBLY.
- CONNECT AIR TUBING TO THE FITTING ON THE COMPRESSOR ASSEMBLY.
- APPLY BLUE THREAD LOCKER TO THE FASTENERS, AND MOUNT COMPRESSOR ASSEMBLY TO THE FRAME RAILS IN FRONT OF THE OIL PAN AS SHOWN IN **FIGURE B**.
- ROUTE AIR TUBING TO THE BATTERY COMPARTMENT ALONG WITH THE WIRING HARNESS, AND SECURE WITH CABLE-TIES. AVOID HOT COMPONENTS.

4

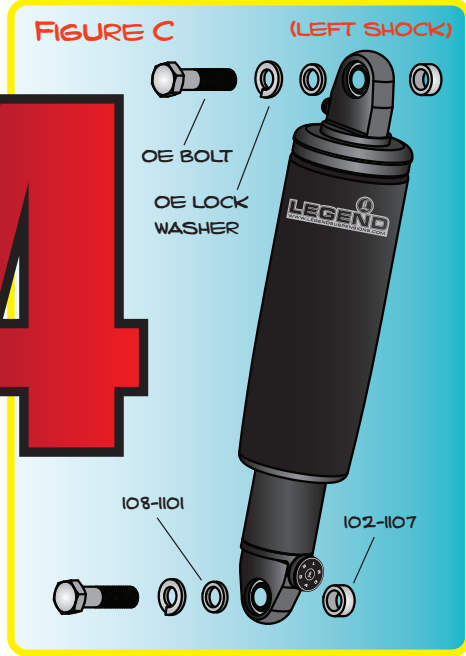
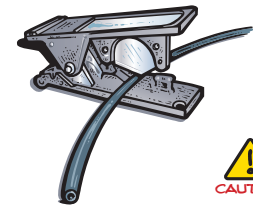

FIGURE C (LEFT SHOCK)

STEP FOUR: SHOCKS

- WITH MOTORCYCLE PROPERLY SUPPORTED ON JACK, REMOVE THE OE SHOCKS.
- APPLY BLUE THREAD LOCKER TO THE FASTENERS, AND INSTALL YOUR LEGEND SHOCKS ACCORDING TO THE HARDWARE CONFIGURATION IN **FIGURE C**, WITH AIR FITTINGS POINTING FORWARD.
- TORQUE HARDWARE TO OE SPECIFICATIONS.
- ROUTE AIR TUBING FROM EACH SHOCK AND CONNECT TO AIR TUBING FROM THE COMPRESSOR USING SUPPLIED Y-FITTING.



MAKE SURE TUBING IS CUT AT A CLEAN 90° ANGLE

STEP FIVE: OPERATION

- REINSTALL THE FUSE IN THE FUSE HOLDER
- PUSH TOP BUTTON TO INFLATE SHOCKS, AND BOTTOM BUTTON TO DEFLATE SHOCKS.
- CHECK TIRE TO FENDER CLEARANCE WHEN SHOCKS ARE FULLY COMPRESSED.
- WITHOUT SITTING ON THE BIKE, INFLATE SHOCKS UNTIL THE BIKE STOPS RISING.
- THE BIKE SHOULD SAG DOWN LESS THAN ONE INCH WHEN YOU SIT ON YOUR BIKE WITH ALL THE WEIGHT YOU WILL BE RIDING WITH.
- THE REBOUND DAMPING CONTROLS THE SPEED AT WHICH THE SHOCKS ABSORBER EXTENDS AFTER BEING COMPRESSED DURING IMPACT. NOT ENOUGH REBOUND DAMPING LET THE SUSPENSION SPRING BACK TOO QUICKLY AND THE BIKE FEEL UNSTABLE. TOO MUCH REBOUND DAMPING CAUSES THE REAR TO JUMP ON BUMPS INSTEAD OF FOLLOWING THE SURFACE.
- GO RIDING, AND ADJUST SPRING RATE ON-THE-GO TO YOUR PREFERENCE.

5

PARTS INCLUDED:

- | | |
|------------------------------------|--|
| (1) 112-2107 - RHS SHOCK | (1) 200-3002 - AIR TUBING, 8 FT. |
| (1) 112-2108 - LHS SHOCK | (1) 200-3000 - TUBE CUTTER |
| (1) 112-1206 - COMPRESSOR ASSEMBLY | (4) 102-1107 - SPACER, 0.50 X 0.75 X 0.33" |
| (1) 800-0054 - WIRING HARNESS | (4) 108-1101 - SPACER, 0.50 X 0.75 X 0.12" |
| (1) 200-1711 - HANDLEBAR CONTROL | (1) 200-2003 - Y-FITTING |