

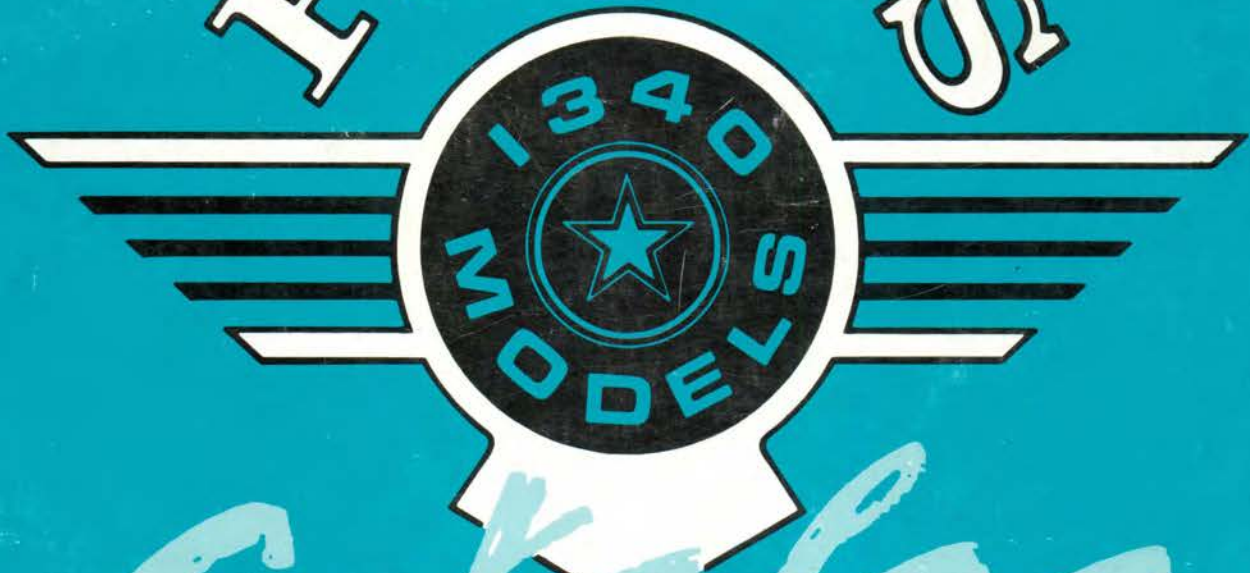

Harley-Davidson Motor Company

1993 and 1994

PARTS



Catalog

GENERAL INFORMATION

This Parts Catalog has been prepared for your convenience when ordering parts for the 1993/1994 1340cc models. This unique combined format allows you to compare the parts usage on all FLT, FXR, Softail and Dyna model motorcycles. Refer to the Glossary at the end of the book for unfamiliar abbreviations. A complete Hardware Listing is also featured. Wherever possible, parts are shown in assembly breakdown sequence. Index numbers shown in the illustrations correspond to index numbers in parts lists. Consult the illustrations when ordering parts so you are sure to get the part required. Number in parenthesis following description of parts is the quantity needed for complete assembly. If there is no number in parenthesis, only one is used. Prices of parts in this catalog are published separately.

The following instructions should be followed carefully when ordering parts.

- The model usage column has a two character code, corresponding to the V.I.N. Model Designation. If the part fits all models "All" will be in the appropriate model usage column. The models classified as FLT, FXR, Softail or Dyna and the two character codes are listed at the bottom of each right hand, odd numbered page.

- Specify the correct part number for each item. Check the "Used On" column of the parts list which shows the model on which the part fits. Whenever in doubt, refer to the Vehicle Identification Number (V.I.N.). A 17 digit V.I.N. is stamped on the front of the frame and frame right downtube label. An abbreviated V.I.N. is stamped on the left engine crankcase.

Always give one of these numbers when ordering parts or making any inquiry about your motorcycle.

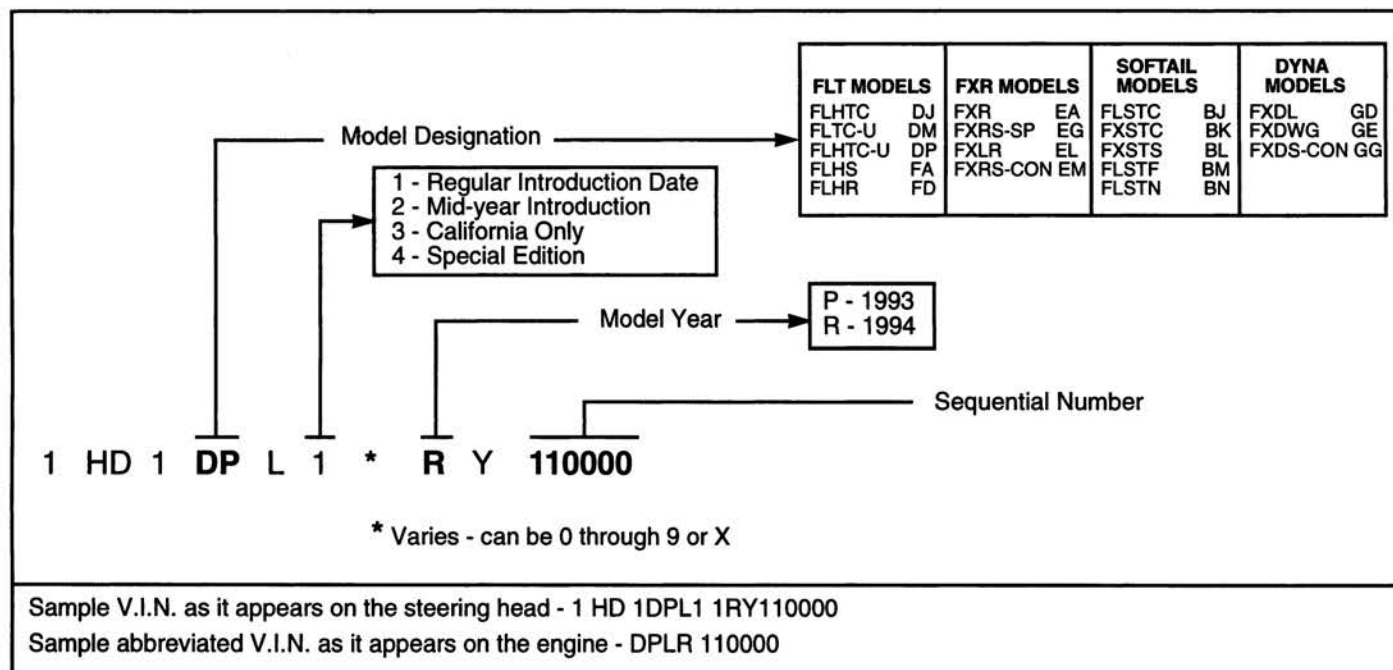

- An asterisk (*) in the "Used On" column indicates part is used thru the current model year.

- All parts which were added for the new model year will have a vertical bar located to the left of the index number. This can be used to quickly locate new parts and to help distinguish between new and previous model year parts.

Example:

1 16114-94 ENGINE ASM., complete (1340 cc) 94 *-ALL

- When ordering parts, use our standard Parts & Accessories order form, Part No. 1125A, for all parts except engines and crankcases. Order form, Part No. 99514-76, must be used for engines and crankcases. The use of these forms will enable us to fill and ship your order promptly. These forms are furnished free of charge upon request.

- Do not order motorcycles or advertising material on Parts Order Forms. Write nothing on the order form except the order itself, as any other correspondence will not be answered until the order is shipped and billed.

COPYRIGHT 1994 BY HARLEY-DAVIDSON MOTOR COMPANY, ALL RIGHTS RESERVED



Printed in U.S.A.
on Recycled Paper

ALPHABETICAL INDEX

DESCRIPTION	PAGE	DESCRIPTION	PAGE
Air Cleaner.....	27,29	Instruments - Softail	251,253
Air Control, front fork.....	111,113	Jiffy Stand.....	117,121,125,127
Alternator	31	License Plate Bracket.....	129,197
Battery.....	233	Luggage Carrier - FLT	129
Battery Tray.....	235,237	Mirrors	321
Belt, rear	59,61	Module, ignition	35
Belt Guard.....	63	Nacelle - FLHR.....	177
Brake Caliper, front	67	Numerical Index	359
Brake Caliper, rear.....	83,85	Oil Filters & Mounts	223
Brake Control, front.....	65	Oil Pump.....	21
Brake Control, rear.....	73-81	Oil Tank - FXR & Softail	221
Brake Disc.....	71,87	Oil Tank - FLT & DYNA.....	49,51
C. B. System.....	297	Passing Lamps.....	183,185
Cam Gears.....	17	Pistons & Piston Rings	11
Carburetor.....	23	Primary Housing.....	201,203
Chain, primary.....	59	Push Rods.....	9
Circuit Breakers	301-309	Regulator.....	31
Clutch.....	55	Rocker Arms.....	7
Clutch Control.....	57	Rotor, ignition	35
Coil, ignition	35	Saddlebags	311-317
Connecting Rods	11	Saddlebag Guards	319
Covers, rocker arm	7	Seats	129-135
Crankcase.....	15	Sensor Assembly.....	35
Cruise Control.....	159	Shock Absorbers	149,151
Cylinders, engine	3	Sidecar	323-349
Engine.....	3,5	Sissy Bar	131,133,135
Engine Guard.....	117	Sound System	293,295,349
Enrichener Cable	29	Spark Plugs.....	35
Evaporative Emissions Kit	351	Speakers	295,349
Exhaust Systems	225-231	Speaker Housing, rear	147
Fairing.....	161-169	Speedometer.....	239-255,259
Fairing Lowers	175	Sprockets	59,61,87
Fenders.....	187-195,335	Stabilizer Link, engine	3,15
Fender Supports, rear.....	199	Starter Motor	37,39
Flywheels.....	11	Switches, ignition.....	255,259,301-309
Footboards.....	141	Switches.....	19,159,167,183,299-309
Footrests.....	137,139	Switchers, Handlebar	299
Fork, front.....	91-107	Tachometer.....	241,243
Fork Rockers.....	109	Tail Lamp	263,339
Frame & Rear Fork	115-127	Tail Lamp - Tour-Pak	147
Fuel Gauge	239,249,255,257,259	Tappets.....	9
Fuel Tanks.....	205-215	Throttle Control.....	157,299
Fuel Tank Trim	217,219	Tools.....	311
Fuse Box - C. B.....	303	Tour-Pak.....	143-147
Gear Shifter.....	41,43	Transmission	41-53
Gasket Kits.....	5, 7	Turn Signals	161,183,185,261-265,341
Glossary.....	352	Turn Signal Cancellor.....	301,305,307,309
Handlebar	153,155	Vacuum Switch.....	23
Hardware Listing.....	353	Valves.....	5
Head, cylinder.....	3	Wheels	69,71,87,89,343
Headlamps.....	161,165,177,179,181	Windshields	161,165,171,173,325,347
Horn	267	Wiring.....	269-291
Ignition System	33,35		
Intercom System	297		
Indicator Lamps	239-247,253,255,259		
Inner Fairing - FLHTC.....	169		
Instruments - FLT.....	169,239,241,259		
Instruments - FXR & DYNA	243-249,255,257		

PATENT NOTICE

Harley-Davidson products are manufactured under one or more of the following patents: U.S. Patents - 2986162, 2987934, 2998809, 3116089, 3144631, 3144860, 3226994, 3229792, 3434887, 3559773, 3673359, 3709317, Des. 225,626.

To the best knowledge of Harley-Davidson Motor Company, the material contained herein is accurate as of the date this publication was approved for printing. Harley-Davidson Motor Company reserves the right to change specifications, equipment, or designs at any time without notice and without incurring obligation.

CYLINDERS, HEADS & VALVES V²TM

- REAR SHOWN

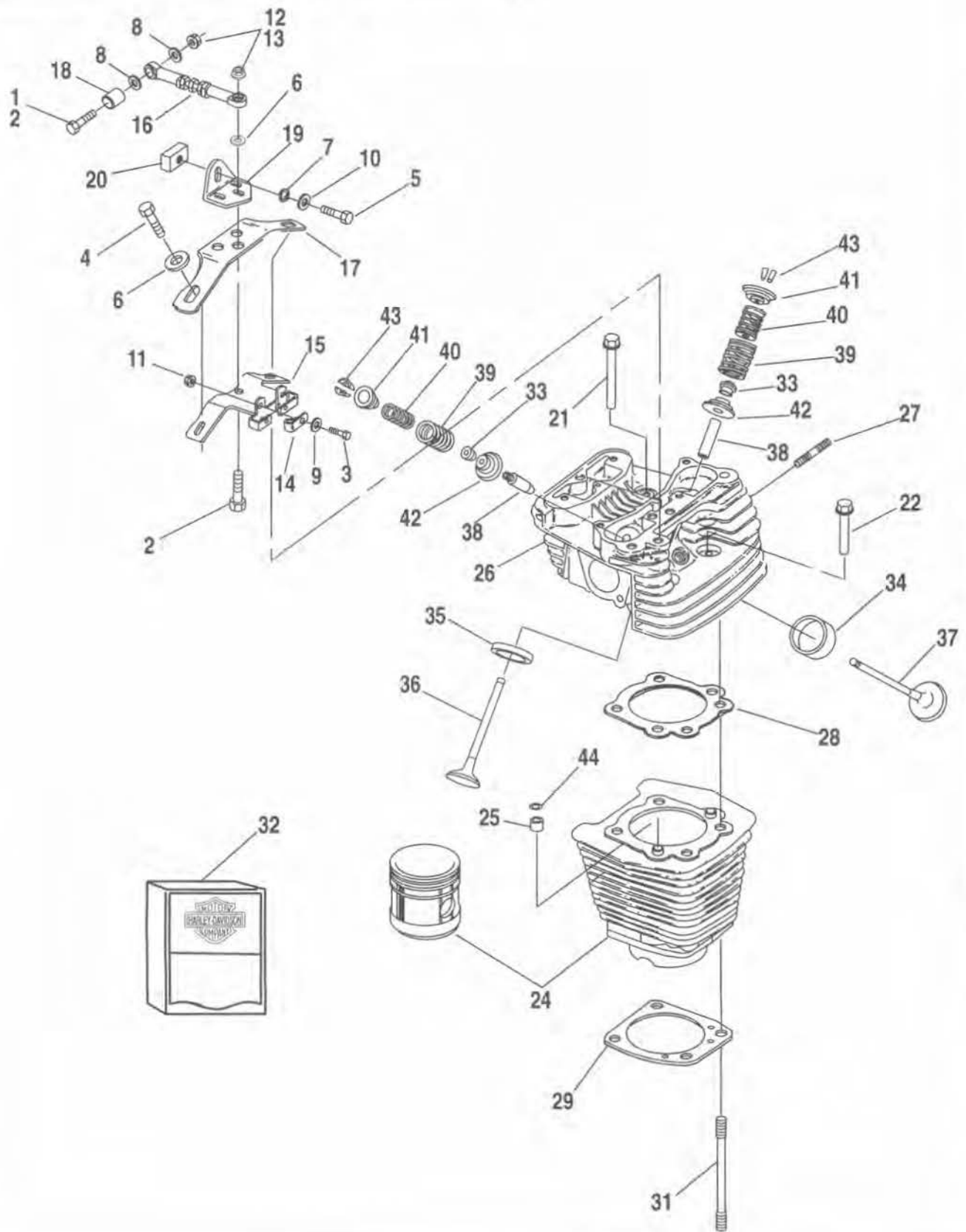

INDEX NO.	PART NO.	DESCRIPTION	FLT MODELS	FXR MODELS	SOFTAIL MODELS	DYNA MODELS
1	855B	BOLT	--	--	--	93*-ALL
	4721	BOLT (2 - FXR)	93*-ALL	93*-ALL	--	--
2	2879W	BOLT (3)	--	--	93*-ALL	--
	4355A	BOLT	93*-ALL	--	--	--
3	2882W	SCREW	--	93*-ALL	--	--
4	4716W	BOLT (2)	93*-ALL	93*-ALL	93*-ALL	93*-ALL
5	4726	BOLT	--	--	93*-ALL	--
6	6019	WASHER (3; 2 - Softail)	93*-ALL	93*-ALL	93*-ALL	93*-ALL
7	6516HW	WASHER	--	--	93*-ALL	--
8	6701	WASHER (2 - FXR)	--	93*-ALL	--	93*-ALL
9	6702	WASHER	--	93*-ALL	--	--
10	7039	LOCKWASHER	--	--	93*-ALL	--
11	7531	NUT	--	93*-ALL	--	--
12	7601	NUT, flange (3 - Softail; 2 - FLT)	93*-ALL	93*-ALL	93*-ALL	93*-ALL
13	7778	LOCKNUT	--	93*-ALL	--	--
14	10003	CLAMP	--	93*-ALL	--	--
	16101-93	ENGINE ASM., complete	93-FA	--	--	--
	16103-93	ENGINE ASM., complete (Cal. only)	93-FA	--	--	--
	16114-93	ENGINE ASM., complete	--	93-EA	--	--
	16114-94	ENGINE ASM., complete	--	94*-EA	--	--
	16121-93	ENGINE ASM., complete (C & BW)	--	--	93-ALL	--
	16121-94	ENGINE ASM., complete (C & BW)	--	--	94*-ALL	--
	16124-93	ENGINE ASM., complete (C & BW)	--	93-EG/L/M	--	--
	16124-94	ENGINE ASM., complete (C & BW)	--	94*-EL	--	--
	16125-93	ENGINE ASM., complete (C & BW)	93-DJ/M/P	--	--	--
	16125-94	ENGINE ASM., complete (C & BW)	94*-DJ/M/P	--	--	--
	16126-93	ENGINE ASM., complete (C & BW)(Cal. only)	--	--	93-ALL	--
	16126-94	ENGINE ASM., complete (C & BW)(Cal. only)	--	--	94*-ALL	--
	16127-93	ENGINE ASM., complete (C & BW)(Cal. only)	93-DJ/M/P	--	--	--
	16127-94	ENGINE ASM., complete (C & BW)(Cal. only)	94*-DJ/P	--	--	--
	16128-93	ENGINE ASM., complete (Cal. only)	--	93-EA	--	--
	16128-94	ENGINE ASM., complete (Cal. only)	--	94*-EA	--	--
	16131-93	ENGINE ASM., complete (C & BW)(Cal. only)	--	93-EG/L/M	--	--
	16131-94	ENGINE ASM., complete (C & BW)(Cal. only)	--	94*-EL	--	--
	16134-94	ENGINE ASM., complete (C & BW)	94*-FD	--	--	--
	16146-94	ENGINE ASM., complete (C & BW)(Cal. only)	94*-FD	--	--	--
	16165-93	ENGINE ASM., complete (C & BW)	--	--	--	93-ALL
	16165-94	ENGINE ASM., complete (C & BW)	--	--	--	94*-ALL
	16166-93	ENGINE ASM., complete (C & BW)(Cal. only)	--	--	--	93-ALL
	16166-94	ENGINE ASM., complete (C & BW)(Cal. only)	--	--	--	94*-ALL
15	16216-91	BRACKET, engine mounting	--	93*-ALL	--	--
16	16219-79A	STABILIZER LINK, top	93*-ALL	93*-ALL	--	93*-ALL
17	16242-90	BRACKET, engine mounting	93*-ALL	--	93*-ALL	93*-ALL
18	16241-90	SPACER	--	--	--	93*-ALL
19	16247-91	BRACKET, engine mounting	--	--	93*-ALL	--
20	16284-84	MOUNTING BLOCK	--	--	93*-ALL	--
21	16478-85A	SCREW, internal thread (4)	93*-ALL	93*-ALL	93*-ALL	93*-ALL
22	16480-92	SCREW, internal thread (4)	93*-ALL	93*-ALL	93*-ALL	93*-ALL
24	16510-83A	CYLINDER W/ PISTON (2)	93-FA	93*-EA	--	--
	16512-86A	CYLINDER W/ PISTON (black wrinkle)(2)	93-DJ/M/P; 94*-ALL	93*-EG/L/M	93*-ALL	93*-ALL

FLT MODELS

FLHTC DJ
 FLTC-U DM
 FLHTC-U DP
 FLHS FA
 FLHR FD

FXR MODELS

FXR EA
 FXRS-SP EG
 FXLR EL
 FXRS-CON EM

SOFTAIL MODELS

FLSTC BJ
 FXSTC BK
 FXSTS BL
 FLSTF BM
 FLSTN BN

DYNA MODELS

FXDL GD
 FXDWG GE
 FXDS-CON GG

CYLINDERS, HEADS & VALVES V²TM

- REAR SHOWN

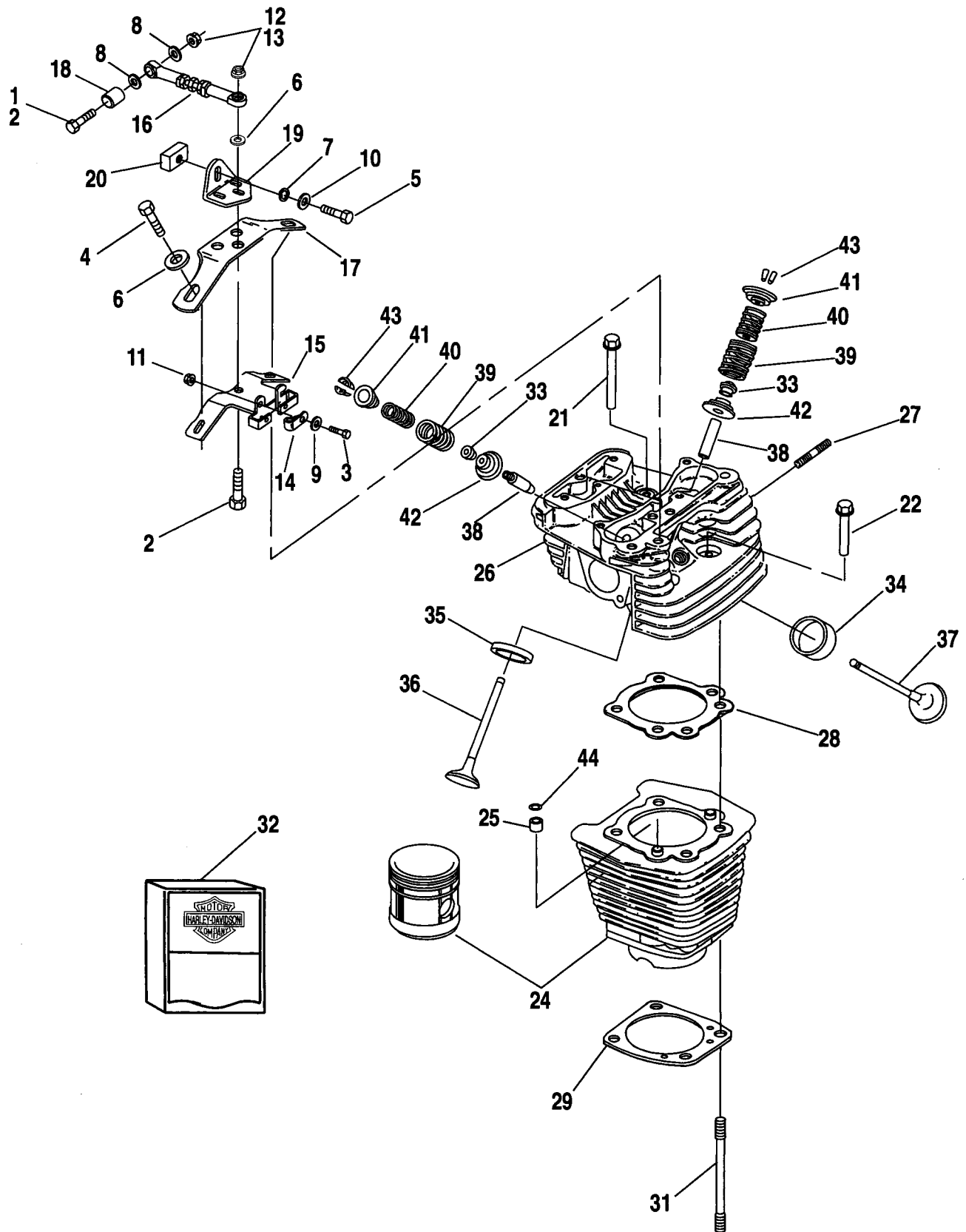

INDEX NO.	PART NO.	DESCRIPTION	FLT MODELS	FXR MODELS	SOFTAIL MODELS	DYNA MODELS
25	16573-83	INSERT, cylinder stud (4)	93*-ALL	93*-ALL	93*ALL	93*-ALL
26	16690-92	HEAD, rear cylinder w/guides & seats	93*-FA	93*-EA	--	--
	16691-92	HEAD, front cylinder w/guides & seats	93*-FA	93*-EA	--	--
	16692-92	HEAD, front cylinder w/guides & seats (blk wrkl)	93-DJ/M/P; 94*-ALL	93*-EG/L/M	93*-ALL	93*-ALL
	16696-92	HEAD, rear cylinder w/guides & seats (blk wrkl)	93-DJ/M/P; 94*-ALL	93*-EG/L/M	93*-ALL	93*-ALL
27	16715-83	STUD, exhaust port (4)	93*-ALL	93*-ALL	93*-ALL	93*-ALL
28	16770-84B	GASKET, cylinder head (2)	93*-ALL	93*-ALL	93*-ALL	93*-ALL
29	16774-86C	GASKET, cylinder base (2)	93*-ALL	93*-ALL	93*-ALL	93*-ALL
31	16837-85B	STUD, cylinder base (8)	93*-ALL	93*-ALL	93*-ALL	93*-ALL
32	17040-92A	GASKET KIT, top overhaul	93*-ALL	93*-ALL	93*-ALL	93*-ALL
	17041-92A	GASKET KIT, engine overhaul	93*-ALL	93*-ALL	93*-ALL	93*-ALL
33	18001-83B	SEAL, valve (4)	93*-ALL	93*-ALL	93*-ALL	93*-ALL
34	18011-86	INSERT, exhaust valve seat (2)	93*-ALL	93*-ALL	93*-ALL	93*-ALL
	18124-83	INSERT, exhaust valve seat - 0.005 O.S. (2)	93*-ALL	93*-ALL	93*-ALL	93*-ALL
35	18020-83	INSERT, intake valve seat (2)	93*-ALL	93*-ALL	93*-ALL	93*-ALL
	18134-83	INSERT, intake valve seat - 0.005 O.S. (2)	93*-ALL	93*-ALL	93*-ALL	93*-ALL
36	18074-83A	INTAKE VALVE (2)	93*-ALL	93*-ALL	93*-ALL	93*-ALL
1	18076-83	INTAKE VALVE, 0.03 short(2)	93*-ALL	93*-ALL	93*-ALL	93*-ALL
37	18082-83	EXHAUST VALVE (2)	93*-ALL	93*-ALL	93*-ALL	93*-ALL
	18087-83	EXHAUST VALVE, 0.030 short (2)	93*-ALL	93*-ALL	93*-ALL	93*-ALL
38	18112-92	VALVE GUIDE, int. & exh. (4)	93*-ALL	93*-ALL	93*-ALL	93*-ALL
	18130-83C	VALVE GUIDE, int. & exh. - 0.001 O.S. (4)	93*-ALL	93*-ALL	93*-ALL	93*-ALL
	18131-83C	VALVE GUIDE, int. & exh. - 0.003 O.S. (4)	93*-ALL	93*-ALL	93*-ALL	93*-ALL
	18133-83A	VALVE GUIDE, int. & exh. - 0.002 O.S. (4)	93*-ALL	93*-ALL	93*-ALL	93*-ALL
39	18201-83	VALVE SPRING, outer (4)	93*-ALL	93*-ALL	93*-ALL	93*-ALL
40	18202-83	VALVE SPRING, inner (4)	93*-ALL	93*-ALL	93*-ALL	93*-ALL
41	18219-83	COLLAR, valve spring - upper (4)	93*-ALL	93*-ALL	93*-ALL	93*-ALL
42	18222-83	COLLAR, valve spring - lower (4)	93*-ALL	93*-ALL	93*-ALL	93*-ALL
43	18229-83	RETAINER, valve collar (8)	93*-ALL	93*-ALL	93*-ALL	93*-ALL
44	26432-76A	O-RING, cylinder stud insert (4)	93*-ALL	93*-ALL	93*-ALL	93*-ALL

H-D INTERNATIONAL ONLY

	16115-93	ENGINE ASM., complete (HDI only)	--	93-EA	--	--
	16115-94	ENGINE ASM., complete (HDI only)	--	94*-EA	--	--
	16122-93	ENGINE ASM., complete (C & BW)(HDI only)	--	--	93-ALL	--
	16122-94	ENGINE ASM., complete (C & BW)(HDI only)	--	--	94*-ALL	--
	16123-93	ENGINE ASM., complete (C & BW)(HDI only)	--	93-EG/L/M	--	--
	16123-94	ENGINE ASM., complete (C & BW)(HDI only)	--	94*-EL	--	--
	16135-93	ENGINE ASM., complete (HDI only)	L93-FA	--	--	--
	16136-93	ENGINE ASM., complete (C & BW)(HDI only)	L93-DJ/M/P	--	--	--
	16136-94	ENGINE ASM., complete (C & BW)(HDI only)	94*-DJ//P	--	--	--
	16137-94	ENGINE ASM., complete (C & BW)(HDI only)	94*-FD	--	--	--
	16167-93	ENGINE ASM., complete (C & BW)(HDI only)	--	--	--	93-ALL
	16167-94	ENGINE ASM., complete (C & BW)(HDI only)	--	--	--	94*-ALL

FLT MODELS

FLHTC
FLTC-U
FLHTC-U
FLHS
FLHR

DJ
DM
DP
FA
FD

FXR MODELS

FXR
FXRS-SP
FXLR
FXRS-CON

EA
EG
EL
EM

SOFTAIL MODELS

FLSTC
FXSTC
FXSTS
FLSTF
FLSTN

BJ
BK
BL
BM
BN

DYNA MODELS

FXDL
FXDWG
FXDS-CON

GD
GE
GG

ROCKER ARMS, COVERS & PUSH RODS - V²™

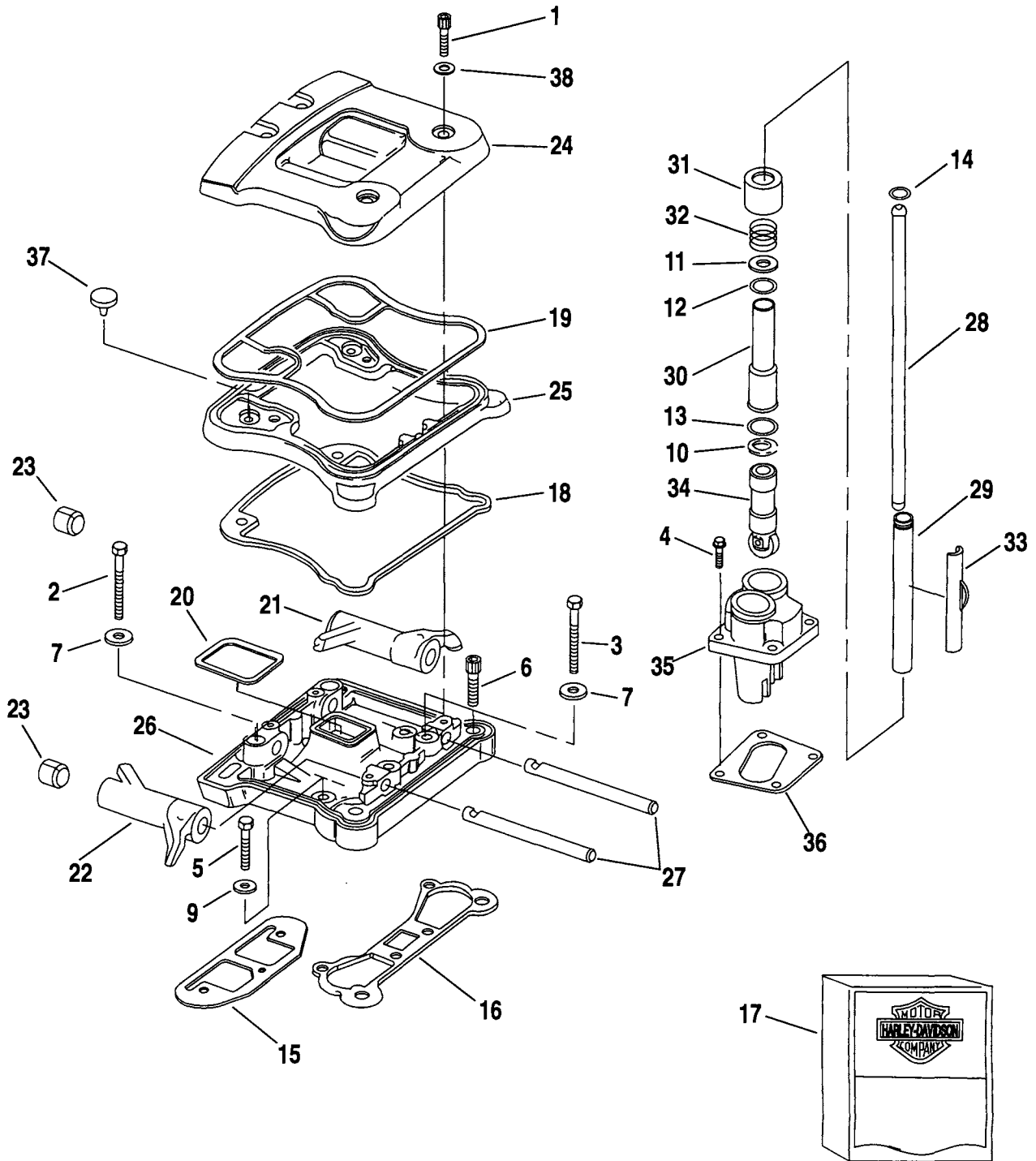

NOTE: PATENT PENDING

INDEX NO.	PART NO.	DESCRIPTION	FLT MODELS	FXR MODELS	SOFTAIL MODELS	DYNA MODELS
1	882	SCREW (8)	93*-ALL	93*-ALL	93*-ALL	93*-ALL
2	3500	BOLT (4)	93*-ALL	93*-ALL	93*-ALL	93*-ALL
3	3501	BOLT (4)	93*-ALL	93*-ALL	93*-ALL	93*-ALL
4	3770	SCREW (8)	93*-ALL	93*-ALL	93*-ALL	93*-ALL
5	3997	BOLT (6)	93*-ALL	93*-ALL	93*-ALL	93*-ALL
6	4718A	SCREW (4)	93*-ALL	93*-ALL	93*-ALL	93*-ALL
7	6016	WASHER (8)	93*-ALL	93*-ALL	93*-ALL	93*-ALL
9	6736	WASHER (6)	93*-ALL	93*-ALL	93*-ALL	93*-ALL
10	6737	WASHER (4)	93*-ALL	93*-ALL	93*-ALL	93*-ALL
11	6762B	WASHER (4)	93*-ALL	93*-ALL	93*-ALL	93*-ALL
12	11132	O-RING, push rod cover (4)	93*-ALL	93*-ALL	93*-ALL	93*-ALL
13	11145	O-RING, push rod cover (4)	93*-ALL	93*-ALL	93*-ALL	93*-ALL
14	11157	O-RING (4)	93*-ALL	93*-ALL	93*-ALL	93*-ALL
15	16778-84A	GASKET, cylinder head - right (2)	93*-ALL	93*-ALL	93*-ALL	93*-ALL
16	16779-84A	GASKET, cylinder head - left (2)	93*-ALL	93*-ALL	93*-ALL	93*-ALL
17	17042-92A	GASKET KIT, rocker boxes with #15, 16, 18, 19, 20, 37 & 38	93*-ALL	93*-ALL	93*-ALL	93*-ALL
18	17355-92	GASKET, rocker cover - lower (2)	93*-ALL	93*-ALL	93*-ALL	93*-ALL
19	17356-92	GASKET, rocker cover - upper (2)	93*-ALL	93*-ALL	93*-ALL	93*-ALL
20	17358-84A	GASKET, rocker cover - inner (2)	93*-ALL	93*-ALL	93*-ALL	93*-ALL
21	17360-83	ROCKER ARM, front intake, rear exhaust (2)	93*-ALL	93*-ALL	93*-ALL	93*-ALL
22	17375-83	ROCKER ARM, rear intake, front exhaust (2)	93*-ALL	93*-ALL	93*-ALL	93*-ALL
23	17428-57	BUSHING, rocker arm (8)	93*-ALL	93*-ALL	93*-ALL	93*-ALL
24	17503-92	ROCKER COVER, outer (2)	93-FA	93*-EA	--	--
	17528-92	ROCKER COVER, outer (chrome)(2)	93-DJ/M/P; 94*-ALL	93*-EG/L/M	93*-ALL	93*-ALL
25	17510-92	SPACER, rocker covers (2)	93-FA	93*-EA	--	--
	17529-92	SPACER, rocker covers (chrome)(2)	93-DJ/M/P; 94*-ALL	93*-EG/L/M	93*-ALL	93*-ALL
26	17521-92	ROCKER COVER, inner (2)	93-FA	93*-EA	--	--
	17530-92	ROCKER COVER, inner (chrome)(2)	93-DJ/M/P; 94*-ALL	93*-EG/L/M	93*-ALL	93*-ALL

NOTE: PATENT PENDING

FLT MODELS

FLHTC DJ
 FLTC-U DM
 FLHTC-U DP
 FLHS FA
 FLHR FD

FXR MODELS

FXR EA
 FXRS-SP EG
 FXLR EL
 FXRS-CON EM

SOFTAIL MODELS

FLSTC BJ
 FXSTC BK
 FXSTS BL
 FLSTF BM
 FLSTN BN

DYNA MODELS

FXDL GD
 FXDWG GE
 FXDS-CON GG

ROCKER ARMS, COVERS & PUSH RODS - V²™

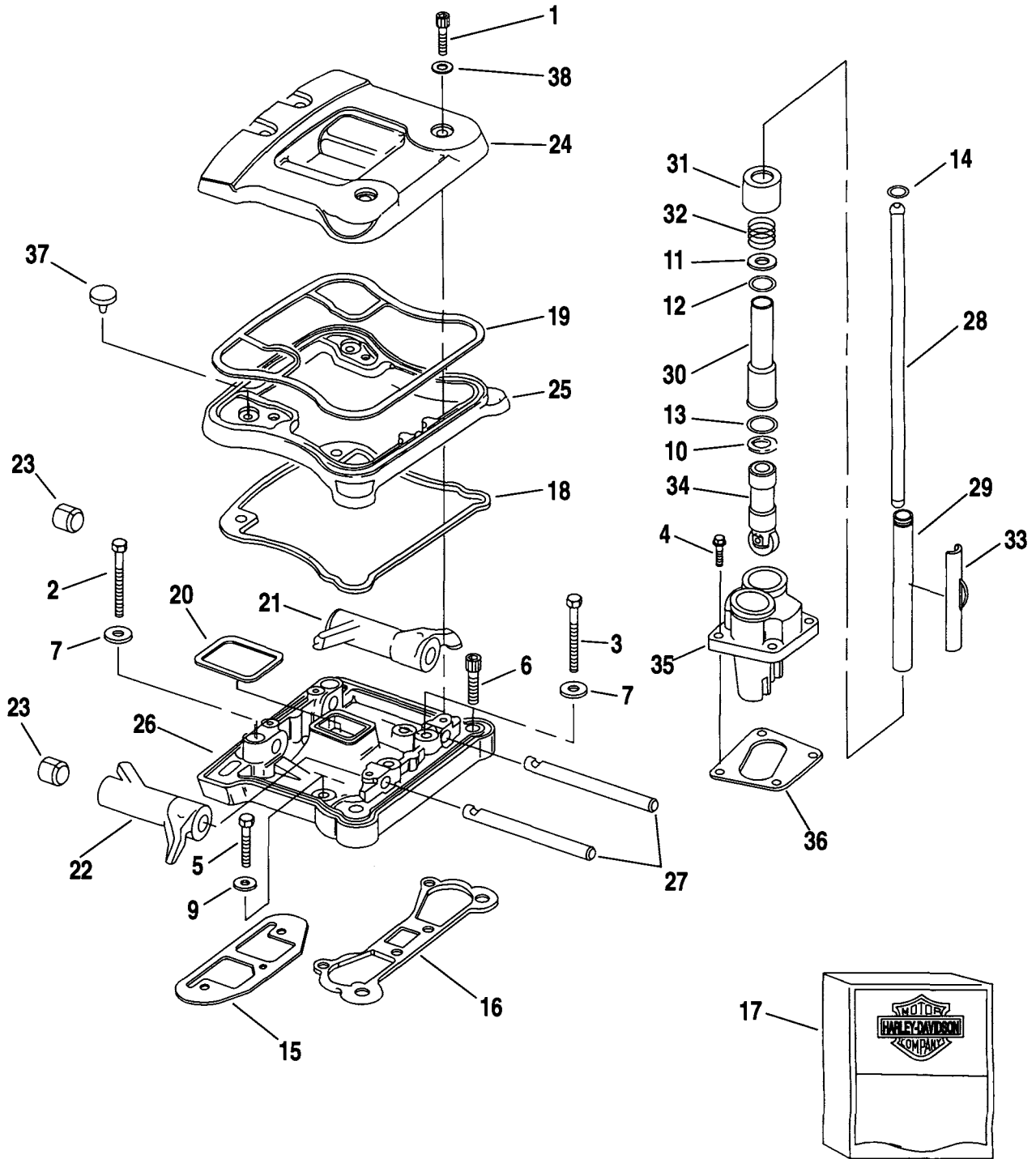

NOTE: PATENT PENDING

INDEX NO.	PART NO.	DESCRIPTION	FLT MODELS	FXR MODELS	SOFTAIL MODELS	DYNA MODELS
27	17611-83	SHAFT, rocker arm (4)	93*-ALL	93*-ALL	93*-ALL	93*-ALL
28	17921-83	PUSH ROD, rear exhaust - 11.210" long	93*-ALL	93*-ALL	93*-ALL	93*-ALL
	17924-83	PUSH ROD, rear intake - 11.045" long	93*-ALL	93*-ALL	93*-ALL	93*-ALL
	17927-83	PUSH ROD, front exhaust - 11.325" long	93*-ALL	93*-ALL	93*-ALL	93*-ALL
	17930-83	PUSH ROD, front intake - 11.090" long	93*-ALL	93*-ALL	93*-ALL	93*-ALL
29	17935-79B	COVER, push rod - upper (4)	93*-ALL	93*-ALL	93*-ALL	93*-ALL
30	17938-83	COVER, push rod - lower (4)	93*-ALL	93*-ALL	93*-ALL	93*-ALL
31	17945-36B	CAP, cover spring (4)	93*-ALL	93*-ALL	93*-ALL	93*-ALL
32	17947-36	SPRING, push rod cover (4)	93*-ALL	93*-ALL	93*-ALL	93*-ALL
33	17950-66	RETAINER, spring cap (4)	93*-ALL	93*-ALL	93*-ALL	93*-ALL
34	18523-86	TAPPET, with roller (4)	93*-ALL	93*-ALL	93*-ALL	93*-ALL
35	18540-83A	TAPPET GUIDE, rear	93-FA	93*-EA	--	--
	18622-85A	TAPPET GUIDE, rear (black wrinkle)	93-DJ/M/P; 94*-ALL	93*-EG/L/M	93*-ALL	93*-ALL
	18542-83A	TAPPET GUIDE, front	93-FA	93*-EA	--	--
	18623-85A	TAPPET GUIDE, front (black wrinkle)	93-DJ/M/P; 94*-ALL	93*-EG/L/M	93*-ALL	93*-ALL
36	18633-48D	GASKET, tappet guide - rear	93*-ALL	93*-ALL	93*-ALL	93*-ALL
	18634-48C	GASKET, tappet guide - front	93*-ALL	93*-ALL	93*-ALL	93*-ALL
37	26856-89	VALVE, umbrella	93*-ALL	93*-ALL	93*-ALL	93*-ALL
38	63858-49	GASKET (8)	93*-ALL	93*-ALL	93*-ALL	93*-ALL

NOTE: PATENT PENDING

FLT MODELS

FLHTC DJ
 FLTC-U DM
 FLHTC-U DP
 FLHS FA
 FLHR FD

FXR MODELS

FXR EA
 FXRS-SP EG
 FXLR EL
 FXRS-CON EM

SOFTAIL MODELS

FLSTC BJ
 FXSTC BK
 FXSTS BL
 FLSTF BM
 FLSTN BN

DYNA MODELS

FXDL GD
 FXDWG GE
 FXDS-CON GG

PISTONS, CONNECTING RODS & FLYWHEELS

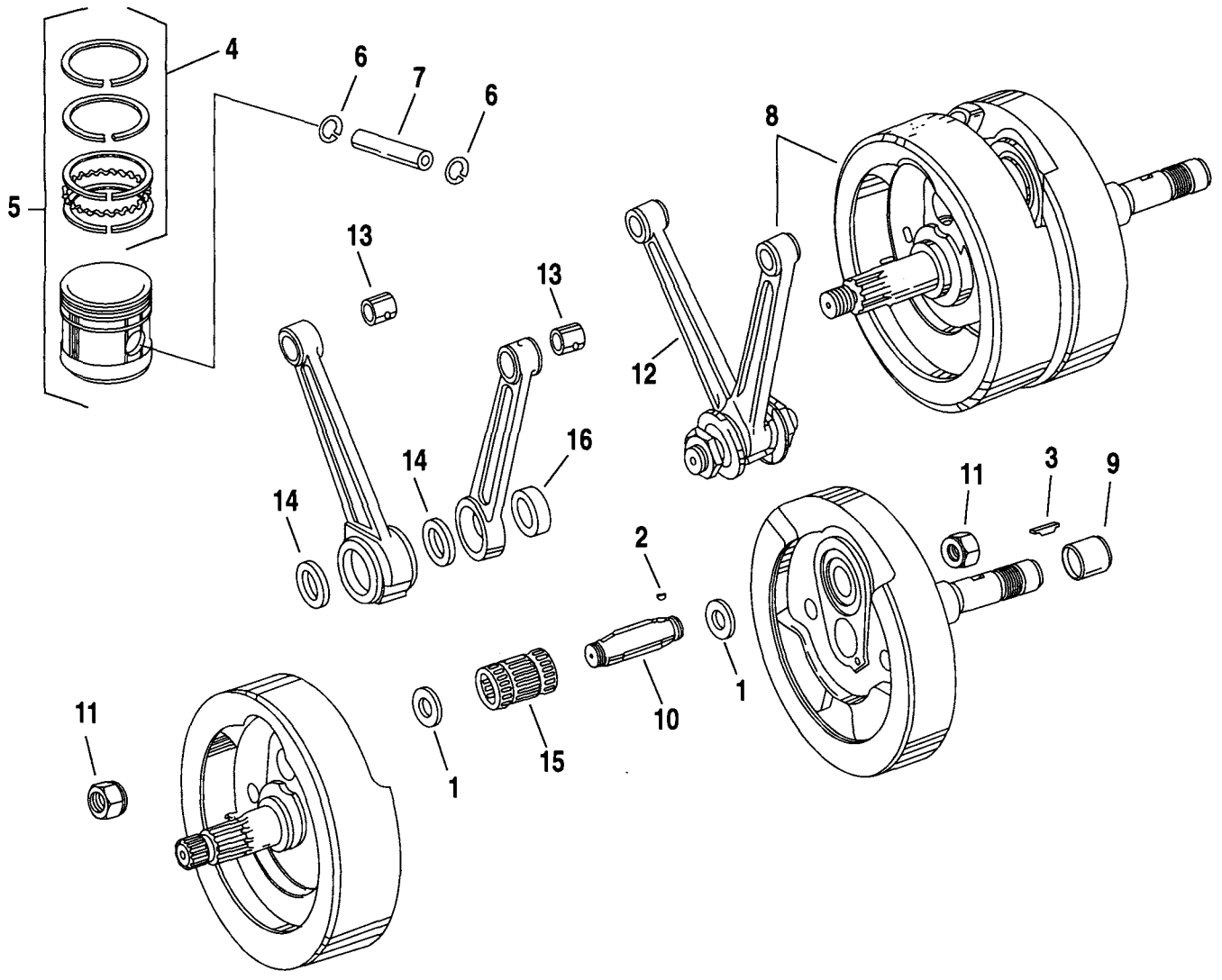

INDEX NO.	PART NO.	DESCRIPTION	FLT MODELS	FXR MODELS	SOFTAIL MODELS	DYNA MODELS
1	6506	WASHER (bronze)(2)	93*-ALL	93*-ALL	93*-ALL	93*-ALL
2	11218	KEY, crank pin & gearshaft	93*-ALL	93*-ALL	93*-ALL	93*-ALL
3	11219	T-KEY	93*-ALL	93*-ALL	93*-ALL	93*-ALL
4	21920-83	PISTON RING SET- std. (2)	93*-ALL	93*-ALL	93*-ALL	93*-ALL
	21921-83	PISTON RING SET - 0.005" O.S.(2)	93*-ALL	93*-ALL	93*-ALL	93*-ALL
	21922-83	PISTON RING SET - 0.010" O.S. (2)	93*-ALL	93*-ALL	93*-ALL	93*-ALL
	21923-83	PISTON RING SET - 0.020" O.S. (2)	93*-ALL	93*-ALL	93*-ALL	93*-ALL
	21924-83	PISTON RING SET - 0.030" O.S. (2)	93*-ALL	93*-ALL	93*-ALL	93*-ALL
5	21940-83	PISTON RINGS ASM. - std. (2)	93*-ALL	93*-ALL	93*-ALL	93*-ALL
	21941-83	PISTON AND RINGS ASM. - 0.005" O.S. (2)	93*-ALL	93*-ALL	93*-ALL	93*-ALL
	21942-83	PISTON AND RINGS ASM. - 0.010" O.S. (2)	93*-ALL	93*-ALL	93*-ALL	93*-ALL
	21943-83	PISTON AND RINGS ASM. - 0.020" O.S. (2)	93*-ALL	93*-ALL	93*-ALL	93*-ALL
	21944-83	PISTON AND RINGS ASM. - 0.030" O.S. (2)	93*-ALL	93*-ALL	93*-ALL	93*-ALL
6	22589-83A	LOCK RING, piston pin (4)	93*-ALL	93*-ALL	93*-ALL	93*-ALL
7	22764-83	PISTON PIN (2)	93*-ALL	93*-ALL	93*-ALL	93*-ALL
8	23906-93A	SET OF FLYWHEELS & SHAFT W/RODS	93*-ALL	93*-ALL	93*-ALL	93*-ALL
9	23928-87	INNER RING	93*-ALL	93*-ALL	93*-ALL	93*-ALL
10	23961-80A	CRANK PIN - std.	93*-ALL	93*-ALL	93*-ALL	93*-ALL
	23974-87	CRANK PIN - 0.001" O.S.	93*-ALL	93*-ALL	93*-ALL	93*-ALL
	23975-87	CRANK PIN - 0.002" O.S.	93*-ALL	93*-ALL	93*-ALL	93*-ALL
11	23969-83	NUT, crank pin (2)	93*-ALL	93*-ALL	93*-ALL	93*-ALL
12	24281-83	SET OF RODS W/BRGS. & CRANKPIN	93*-ALL	93*-ALL	93*-ALL	93*-ALL
13	24334-36	BUSHING, piston pin - 0.002" O.S. (2)	93*-ALL	93*-ALL	93*-ALL	93*-ALL
	24335-36	BUSHING, piston pin - 0.010" O.S. (2)	93*-ALL	93*-ALL	93*-ALL	93*-ALL
14	24345-36A	BUSHING, rear conn. rod - lower (2)	93*-ALL	93*-ALL	93*-ALL	93*-ALL
15	24346-87A	BEARING SET	93*-ALL	93*-ALL	93*-ALL	93*-ALL
16	24356-36A	BUSHING, front conn. rod - lower	93*-ALL	93*-ALL	93*-ALL	93*-ALL

FLT MODELS

FLHTC DJ
 FLTC-U DM
 FLHTC-U DP
 FLHS FA
 FLHR FD

FXR MODELS

FXR EA
 FXRS-SP EG
 FXLR EL
 FXRS-CON EM

SOFTAIL MODELS

FLSTC BJ
 FXSTC BK
 FXSTS BL
 FLSTF BM
 FLSTN BN

DYNA MODELS

FXDL GD
 FXDWG GE
 FXDS-CON GG

CRANKCASE

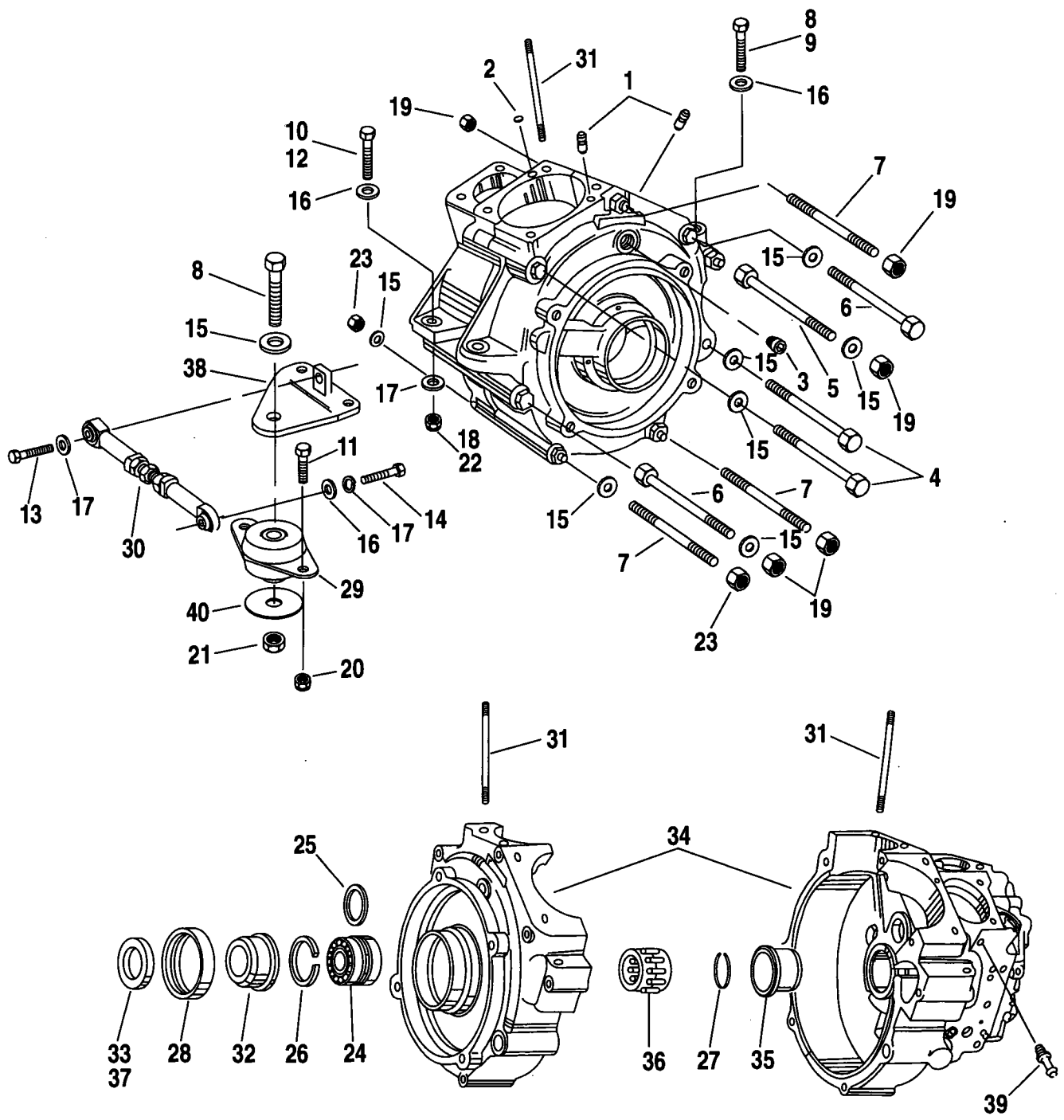

INDEX NO.	PART NO.	DESCRIPTION	FLT MODELS	FXR MODELS	SOFTAIL MODELS	DYNA MODELS
1	358	DOWEL PIN (2)	93*-ALL	93*-ALL	93*-ALL	93*-ALL
2	653	EXPANSION PLUG	93*-ALL	93*-ALL	93*-ALL	93*-ALL
3	720	PLUG, timing hole	93*-ALL	93*-ALL	93*-ALL	93*-ALL
4	3427	BOLT (2)	93*-ALL	93*-ALL	93*-ALL	93*-ALL
5	3430	BOLT	93*-ALL	93*-ALL	93*-ALL	93*-ALL
6	3504	BOLT (2)	93*-ALL	93*-ALL	93*-ALL	93*-ALL
7	3506	STUD (3)	93*-ALL	93*-ALL	93*-ALL	93*-ALL
8	3512	BOLT (2-Softtail)	93*-ALL	93*-ALL	93*-ALL	--
9	3528	BOLT (2)	93*-ALL	93*-ALL	--	93*-ALL
10	3554	BOLT (2)	93*-ALL	93*-ALL	--	93*-ALL
11	4319	BOLT (2)	93*-ALL	93*-ALL	--	--
12	4416	BOLT (2)	--	--	93*-ALL	--
13	4716W	BOLT	93*-ALL	93*-ALL	--	--
14	4721	BOLT	93*-ALL	93*-ALL	--	--
15	6016	WASHER (7)	93*-ALL	93*-ALL	93*-ALL	93*-ALL
16	6019	WASHER (4; 5 FLT, FXR)	93*-ALL	93*-ALL	93*-ALL	93*-ALL
17	7038	LOCKWASHER (4)	93*-ALL	93*-ALL	--	--
18	7506	LOCKNUT (4)	--	--	93*-ALL	--
19	7593	NUT, flange (7)	93*-ALL	93*-ALL	93*-ALL	93*-ALL
20	7780	LOCKNUT (2)	93*-ALL	93*-ALL	--	--
21	7782	NUT	93*-ALL	93*-ALL	--	93*-ALL
22	7783	NUT(2)	93*-ALL	93*-ALL	--	--
23	7883	NUT (2)	93*-ALL	93*-ALL	93*-ALL	93*-ALL
24	9028	BEARING ASM., sprocket shaft	93*-ALL	93*-ALL	93*-ALL	93*-ALL
25	9110	SHIM, brg. asm. 0.0905 - .0895"	93*-ALL	93*-ALL	93*-ALL	93*-ALL
	9120	SHIM, brg. asm. 0.0925 - .0915"	93*-ALL	93*-ALL	93*-ALL	93*-ALL
	9121	SHIM, brg. asm. 0.0945 - .0935"	93*-ALL	93*-ALL	93*-ALL	93*-ALL
	9122	SHIM, brg. asm. 0.0965 - .0955"	93*-ALL	93*-ALL	93*-ALL	93*-ALL
	9123	SHIM, brg. asm. 0.0985 - .0975"	93*-ALL	93*-ALL	93*-ALL	93*-ALL
	9124	SHIM, brg. asm. 0.1005 - .0995"	93*-ALL	93*-ALL	93*-ALL	93*-ALL
	9125	SHIM, brg. asm. 0.1025 - .1015"	93*-ALL	93*-ALL	93*-ALL	93*-ALL
	9126	SHIM, brg. asm. 0.1045 - .1035"	93*-ALL	93*-ALL	93*-ALL	93*-ALL
	9127	SHIM, brg. asm. 0.1065 - .1055"	93*-ALL	93*-ALL	93*-ALL	93*-ALL
	9128	SHIM, brg. asm. 0.1085 - .1075"	93*-ALL	93*-ALL	93*-ALL	93*-ALL
	9129	SHIM, brg. asm. 0.1105 - .1095"	93*-ALL	93*-ALL	93*-ALL	93*-ALL
	9130	SHIM, brg. asm. 0.1125 - .1115"	93*-ALL	93*-ALL	93*-ALL	93*-ALL
	9131	SHIM, brg. asm. 0.1145 - .1135"	93*-ALL	93*-ALL	93*-ALL	93*-ALL
	9132	SHIM, brg. asm. 0.1165 - .1155"	93*-ALL	93*-ALL	93*-ALL	93*-ALL
	9133	SHIM, brg. asm. 0.1185 - .1175"	93*-ALL	93*-ALL	93*-ALL	93*-ALL
	9134	SHIM, brg. asm. 0.1205 - .1195"	93*-ALL	93*-ALL	93*-ALL	93*-ALL
26	11160A	RETAINING RING, brg. - left	93*-ALL	93*-ALL	93*-ALL	93*-ALL
27	11177	RETAINING RING, brg. - right	93*-ALL	93*-ALL	93*-ALL	93*-ALL
28	12026B	OIL SEAL	93*-ALL	93*-ALL	93*-ALL	93*-ALL

FLT MODELS

FLHTC DJ
 FLTC-U DM
 FLHTC-U DP
 FLHS FA
 FLHR FD

FXR MODELS

FXR EA
 FXRS-SP EG
 FXLR EL
 FXRS-CON EM

SOFTAIL MODELS

FLSTC BJ
 FXSTC BK
 FXSTS BL
 FLSTF BM
 FLSTN BN

DYNA MODELS

FXDL GD
 FXDWG GE
 FXDS-CON GG

CRANKCASE

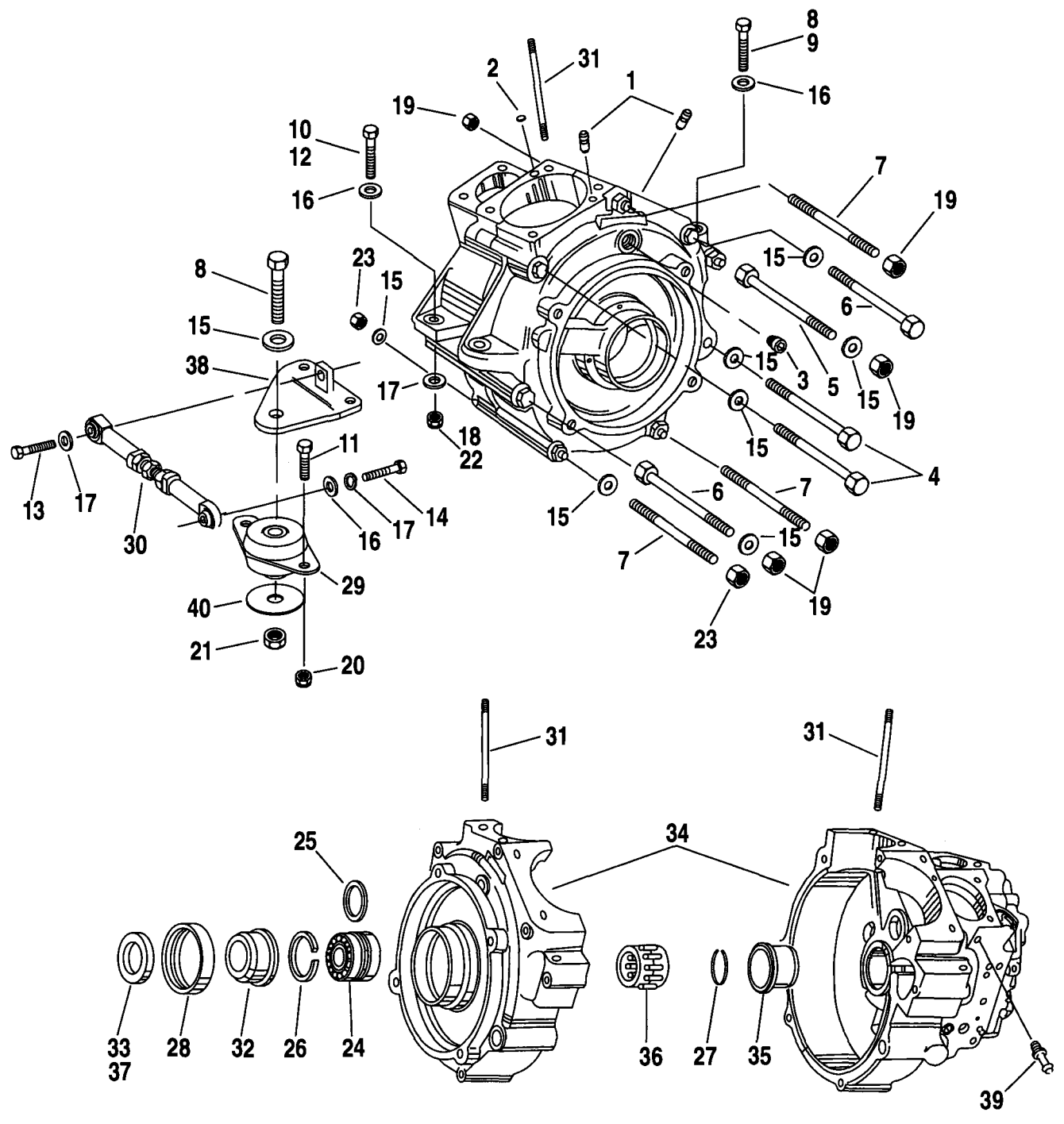

CRANKCASE (CONT'D)

FB4-2

INDEX NO.	PART NO.	DESCRIPTION	FLT MODELS	FXR MODELS	SOFTAIL MODELS	DYNA MODELS
29	16207-79B	ENGINE MOUNT, front	93*-ALL	93*-ALL	--	--
30	16219-79A	STABILIZER LINK, lower	93*-ALL	93*-ALL	--	--
31	16837-85B	STUD, cylinder base (8)	93*-ALL	93*-ALL	93*-ALL	93*-ALL
32	24002-70	SPACER, sprocket shaft	93*-ALL	93*-ALL	93*-ALL	93*-ALL
33	24032-70	SPACER, sprocket shaft - 0.060" thk.	93*-ALL	93*-ALL	93*-ALL	93*-ALL
	24033-70	SPACER, sprocket shaft - 0.090" thk.	93*-ALL	93*-ALL	93*-ALL	93*-ALL
	24034-70	SPACER, sprocket shaft - 0.120" thk.	93*-ALL	93*-ALL	93*-ALL	93*-ALL
	24035-70	SPACER, sprocket shaft - 0.150" thk.	93*-ALL	93*-ALL	93*-ALL	93*-ALL
	24036-70	SPACER, sprocket shaft - 0.180" thk.	93*-ALL	93*-ALL	93*-ALL	93*-ALL
	24037-70	SPACER, sprocket shaft - 0.210" thk.	93*-ALL	93*-ALL	93*-ALL	93*-ALL
34	24571-93	SET OF CRANKCASES (blackwrinkle)	93-DJ/M/P; 94*-ALL	93*-EG/L/M	93*-ALL	93*-ALL
	24572-93	SET OF CRANKCASES	93-FA	93*-EA	--	--
	24599-58B	BUSHING, right crankcase -std.	93*-ALL	93*-ALL	93*-ALL	93*-ALL
35	24600-58B	BUSHING, right crankcase - 0.002" O.S.O.D.	93*-ALL	93*-ALL	93*-ALL	93*-ALL
	24601-58B	BUSHING, right crankcase - 0.005" O.S.O.D.	93*-ALL	93*-ALL	93*-ALL	93*-ALL
	24626-87	BEARING SET, gear side (white/grey)	93*-ALL	93*-ALL	93*-ALL	93*-ALL
36	24628-87	BEARING SET, gear side (green)	93*-ALL	93*-ALL	93*-ALL	93*-ALL
	24641-87	BEARING SET, gear side (red)	93*-ALL	93*-ALL	93*-ALL	93*-ALL
	24643-87	BEARING SET, gear side (blue)	93*-ALL	93*-ALL	93*-ALL	93*-ALL
	35850-84	SPACER, sprocket shaft - 0.010" thk.	93*-ALL	93*-ALL	93*-ALL	93*-ALL
37	35851-84	SPACER, sprocket shaft - 0.020" thk.	93*-ALL	93*-ALL	93*-ALL	93*-ALL
	35852-84	SPACER, sprocket shaft - 0.030" thk.	93*-ALL	93*-ALL	93*-ALL	93*-ALL
	47159-79A	BRACKET, front engine mount	93*-ALL	93*-ALL	--	--
38	63533-41	FITTING, oil hose	93*-ALL	93*-ALL	93*-ALL	93*-ALL
39	96210-80	WASHER	93*-ALL	93*-ALL	--	--

FLT MODELS

FLHTC DJ
 FLTC-U DM
 FLHTC-U DP
 FLHS FA
 FLHR FD

FXR MODELS

FXR EA
 FXRS-SP EG
 FXLR EL
 FXRS-CON EM

SOFTAIL MODELS

FLSTC BJ
 FXSTC BK
 FXSTS BL
 FLSTF BM
 FLSTN BN

DYNA MODELS

FXDL GD
 FXDWG GE
 FXDS-CON GG

CRANKCASE - GEAR SIDE

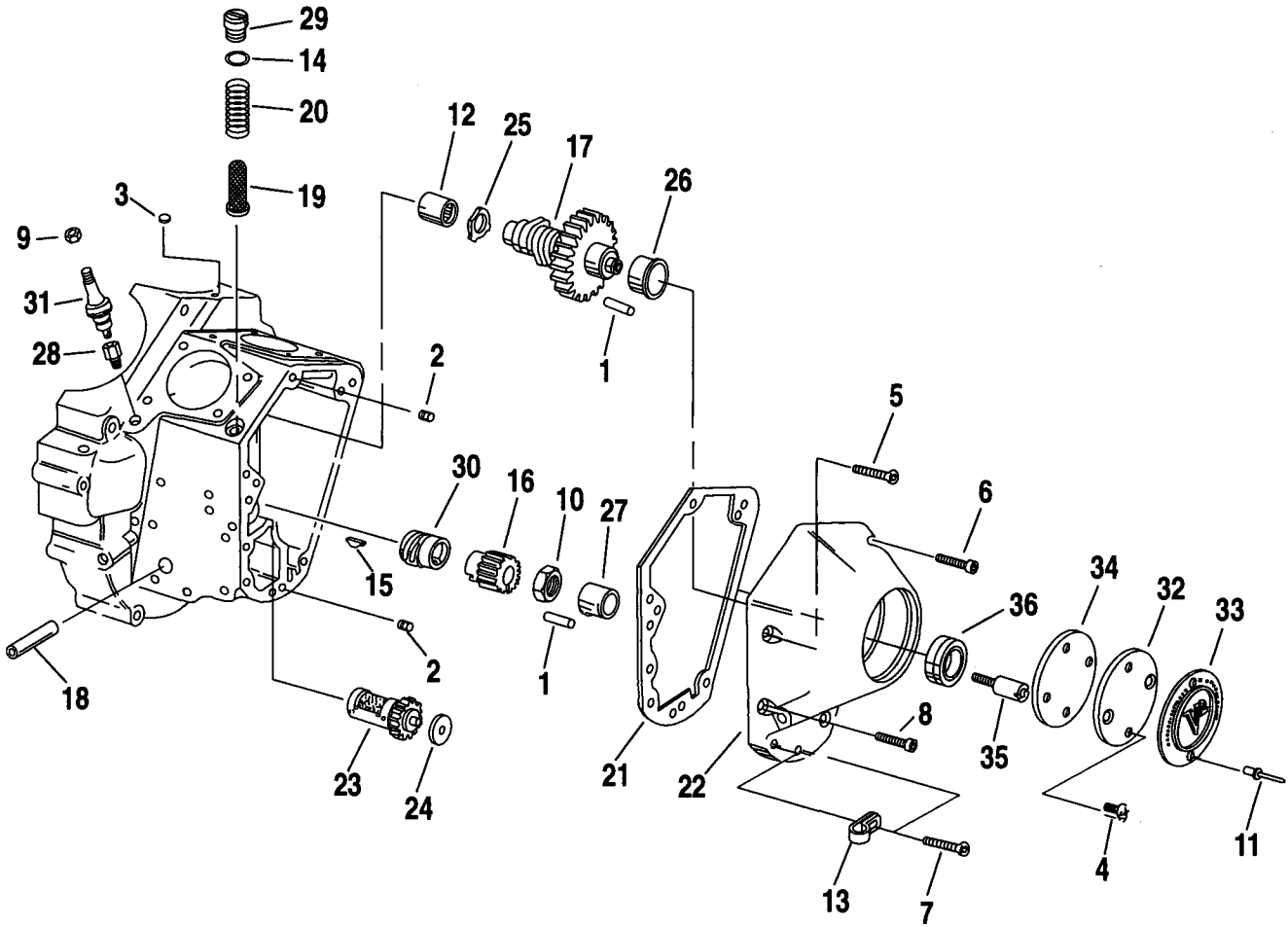

INDEX NO.	PART NO.	DESCRIPTION	FLT MODELS	FXR MODELS	SOFTAIL MODELS	DYNA MODELS
1	275	DOWEL PIN (2 - as required)	93*-ALL	93*-ALL	93*-ALL	--
2	358	DOWEL PIN (2)	93*-ALL	93*-ALL	93*-ALL	93*-ALL
3	653	PLUG, crankcase	93*-ALL	93*-ALL	93*-ALL	93*-ALL
4	1601	SCREW (2)	93*-ALL	93*-ALL	93*-ALL	93*-ALL
5	3480A	SCREW	93*-ALL	93*-ALL	93*-ALL	93*-ALL
6	4813A	SCREW	93*-ALL	93*-ALL	93*-ALL	93*-ALL
7	4718A	SCREW (4 - FXR; 3 - DYNA)	93*-ALL	93*-ALL	93*-ALL	93*-ALL
8	4740A	SCREW (3 - FLT & Softail)	93*-ALL	--	93*-ALL	93*-ALL
9	7629	NUT	--	93*-ALL	93*-ALL	93*-ALL
10	7916A	NUT, gear shaft	93*-ALL	93*-ALL	93*-ALL	93*-ALL
11	8699	RIVET, ignition cover (2)	93*-ALL	93*-ALL	93*-ALL	93*-ALL
12	9058	NEEDLE BEARING, crankcase camcover	93*-ALL	93*-ALL	93*-ALL	93*-ALL
13	10046	CLAMP, ignition wire	--	93*-ALL	--	93*-ALL
14	11105	O-RING	93*-ALL	93*-ALL	93*-ALL	93*-ALL
15	11219	T-KEY	93*-ALL	93*-ALL	93*-ALL	93*-ALL
16	24040-93	PINION GEAR, 1.4850-53 pd. (orange)	93*-ALL	93*-ALL	93*-ALL	93*-ALL
	24041-93	PINION GEAR, 1.4846-49 pd. (white)	93*-ALL	93*-ALL	93*-ALL	93*-ALL
	24042-93	PINION GEAR, 1.4842-45 pd. (yellow)	93*-ALL	93*-ALL	93*-ALL	93*-ALL
	24043-93	PINION GEAR, 1.4838-41 pd. (red)	93*-ALL	93*-ALL	93*-ALL	93*-ALL
	24044-93	PINION GEAR, 1.4834-37 pd. (blue)	93*-ALL	93*-ALL	93*-ALL	93*-ALL
	24045-93	PINION GEAR, 1.4830-33 pd. (green)	93*-ALL	93*-ALL	93*-ALL	93*-ALL
	24046-93	PINION GEAR, 1.4826-29 pd. (black)	93*-ALL	93*-ALL	93*-ALL	93*-ALL
17	24581-93	SET OF CAM & PINION GEARS (matched) (Cal. only)	93*-ALL	93*-ALL	93*-ALL	93*-ALL
	24586-93	SET OF CAM & PINION GEARS (matched)	93*-ALL	93*-ALL	93*-ALL	93*-ALL
18	24641-36	BUSHING, oil pump shaft	93*-ALL	93*-ALL	93*-ALL	93*-ALL
19	24981-70	OIL SCREEN, crankcase	93*-ALL	93*-ALL	93*-ALL	93*-ALL
20	24982-70	SPRING, oil screen	93*-ALL	93*-ALL	93*-ALL	93*-ALL
21	25225-93B	GASKET, gear cover	93*-ALL	93*-ALL	93*-ALL	93*-ALL
22	25254-93A	GEAR COVER	93-FA	93*-EA	--	--
	25256-93A	GEAR COVER, (chrome)	93-D/M/P; 94*-ALL	93*-EG/L/M	93*-ALL	93*-ALL

FLT MODELS

FLHTC DJ
 FLTC-U DM
 FLHTC-U DP
 FLHS FA
 FLHR FD

FXR MODELS

FXR EA
 FXRS-SP EG
 FXLR EL
 FXRS-CON EM

SOFTAIL MODELS

FLSTC BJ
 FXSTC BK
 FXSTS BL
 FLSTF BM
 FLSTN BN

DYNA MODELS

FXDL GD
 FXDWG GE
 FXDS-CON GG

CRANKCASE - GEAR SIDE

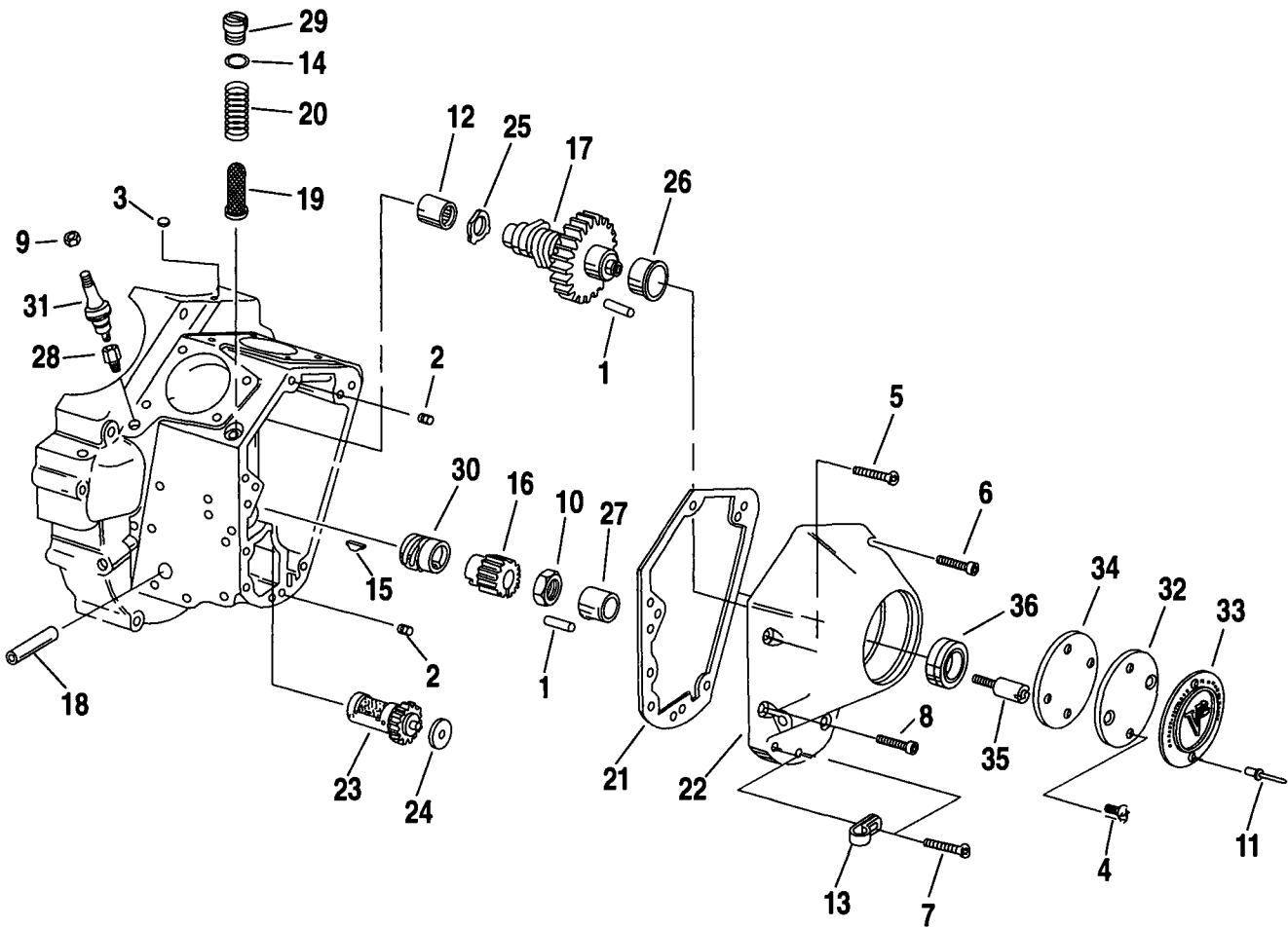

INDEX NO.	PART NO.	DESCRIPTION	FLT MODELS	FXR MODELS	SOFTAIL MODELS	DYNA MODELS
23	25310-82A	BREATHER VALVE GEAR	93*-ALL	93*-ALL	93*-ALL	93*-ALL
24	25320-82	THRUST WASHER, brthr valve - 0.130" thk.	93*-ALL	93*-ALL	93*-ALL	93*-ALL
	25321-82	THRUST WASHER, brthr valve - 0.135" thk.	93*-ALL	93*-ALL	93*-ALL	93*-ALL
	25322-82	THRUST WASHER, brthr valve - 0.140" thk.	93*-ALL	93*-ALL	93*-ALL	93*-ALL
	25323-82	THRUST WASHER, brthr valve - 0.145" thk.	93*-ALL	93*-ALL	93*-ALL	93*-ALL
	25325-82	THRUST WASHER, brthr valve - 0.150" thk.	93*-ALL	93*-ALL	93*-ALL	93*-ALL
	25326-82	THRUST WASHER, brthr valve - 0.155" thk.	93*-ALL	93*-ALL	93*-ALL	93*-ALL
	25327-82	THRUST WASHER, brthr valve - 0.160" thk.	93*-ALL	93*-ALL	93*-ALL	93*-ALL
	25328-82	THRUST WASHER, brthr valve - 0.165" thk.	93*-ALL	93*-ALL	93*-ALL	93*-ALL
	25	25550-57	THRUST WASHER, cam gear	93*-ALL	93*-ALL	93*-ALL
26	25581-70	BUSHING, gear cover	93*-ALL	93*-ALL	93*-ALL	93*-ALL
27	25582-93	BUSHING, gear cover pinion shaft	93*-ALL	93*-ALL	93*-ALL	93*-ALL
28	26052-92A	FITTING, oil pressure	93*-DJ/M/P	--	--	--
29	26263-80	PLUG, oil screen	93*-ALL	93*-ALL	93*-ALL	93*-ALL
30	26354-93	DRIVE GEAR, oil pump	93*-ALL	93*-ALL	93*-ALL	93*-ALL
31	26561-84	OIL PRESSURE SWITCH	93*-FA/D	93*-ALL	93*-ALL	93*-ALL
	74406-87	OIL PRESSURE SWITCH	93*-DJ/M/P	--	--	--
32	32504-80	COVER, inner	93*-ALL	93*-ALL	93*-ALL	93*-ALL
33	32524-83	TIMER COVER	93*-ALL	93*-ALL	93*-ALL	93*-ALL
34	32591-80	GASKET, ignition cover	93*-ALL	93*-ALL	93*-ALL	93*-ALL
35	32606-82	SCREW (2)	93*-ALL	93*-ALL	93*-ALL	93*-ALL
36	83162-51	OIL SEAL, bearing	93*-ALL	93*-ALL	93*-ALL	93*-ALL

FLT MODELS

FLHTC DJ
 FLTC-U DM
 FLHTC-U DP
 FLHS FA
 FLHR FD

FXR MODELS

FXR EA
 FXRS-SP EG
 FXLR EL
 FXRS-CON EM

SOFTAIL MODELS

FLSTC BJ
 FXSTC BK
 FXSTS BL
 FLSTF BM
 FLSTN BN

DYNA MODELS

FXDL GD
 FXDWG GE
 FXDS-CON GG

OIL PUMP

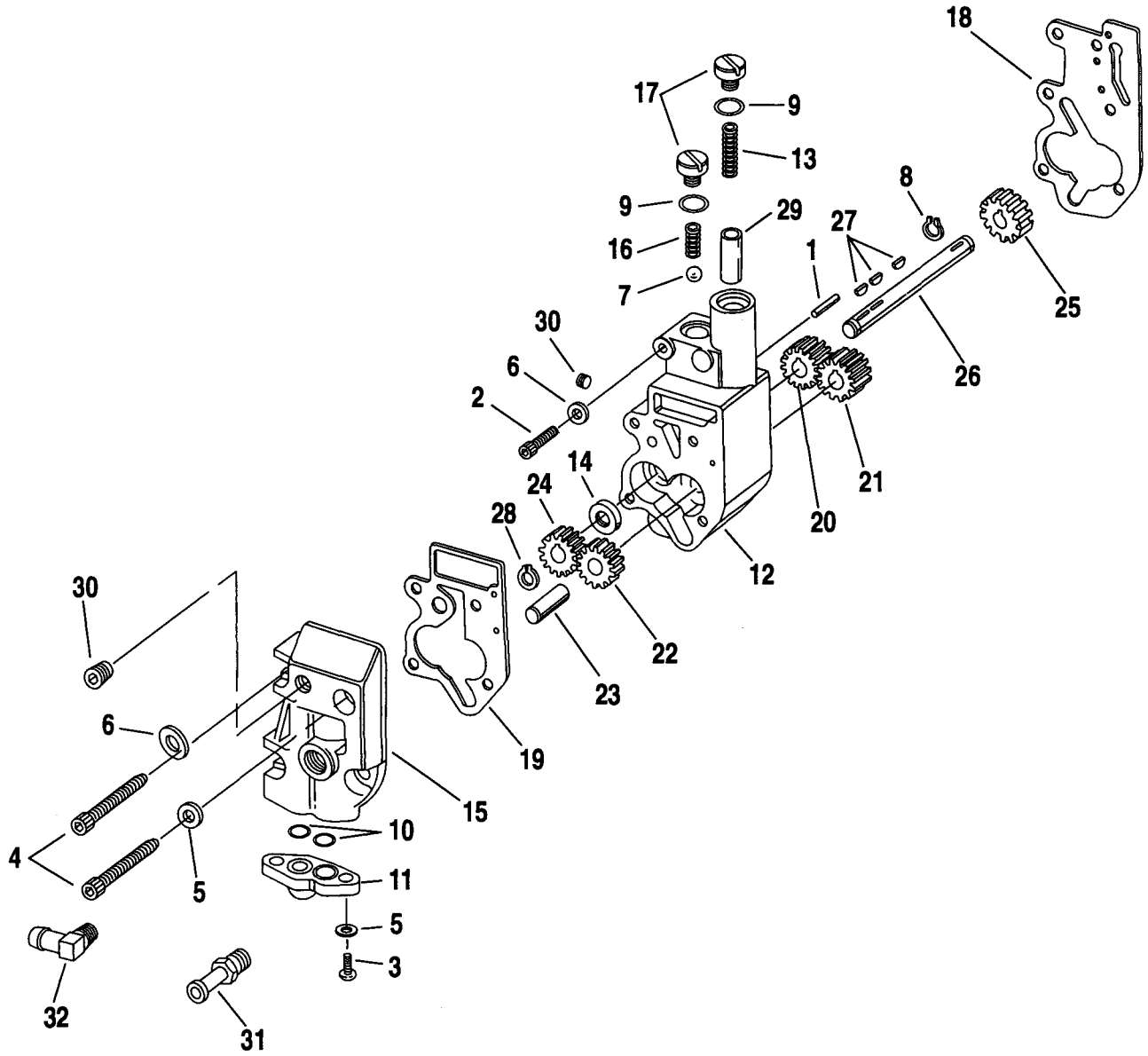

INDEX NO.	PART NO.	DESCRIPTION	FLT MODELS	FXR MODELS	SOFTAIL MODELS	DYNA MODELS
1	239	PIN, valve stop	93*-ALL	93*-ALL	93*-ALL	93*-ALL
2	891	SCREW (2)	93*-ALL	93*-ALL	93*-ALL	93*-ALL
3	927A	SCREW (2)	93*-ALL	93*-ALL	93*-ALL	93*-ALL
4	4742A	SCREW (4)	93*-ALL	93*-ALL	93*-ALL	93*-ALL
5	6099	WASHER (2)	93*-ALL	93*-ALL	93*-ALL	93*-ALL
6	6239	WASHER (4)	93*-ALL	93*-ALL	93*-ALL	93*-ALL
7	8873	BALL, check valve - 3/8" dia.	93*-ALL	93*-ALL	93*-ALL	93*-ALL
8	11002	RETAINING RING, oil pump	93*-ALL	93*-ALL	93*-ALL	93*-ALL
9	11105	O-RING, check valve cover screw (2)	93*-ALL	93*-ALL	93*-ALL	93*-ALL
10	11241	O-RING (2)	93*-ALL	93*-ALL	93*-ALL	93*-ALL
11	26030-92	END CAP (black wrinkle)	93*-ALL	93*-ALL	93*-ALL	93*-ALL
12	26050-92	OIL PUMP (blk wrkl)	93-DJ/M/P; 94*-ALL	93*-EG/L/M	93*-ALL	93*-ALL
13	26053-92	OIL PUMP	93-FA	93*-EA	--	93*-ALL
	26225-92	BODY, oil pump	93-FA	93*-EA	--	93*-ALL
	26226-92	BODY, oil pump (blk wrkl)	93-DJ/M/P; 94*-ALL	93*-EG/L/M	93*-ALL	93*-ALL
14	26207-83	SPRING, relief valve	93*-ALL	93*-ALL	93*-ALL	93*-ALL
15	26227-58	OIL SEAL	93*-ALL	93*-ALL	93*-ALL	93*-ALL
16	26267-92	COVER, oil pump (black wrinkle)	93*-DJ/M/P; 94*-ALL	93*-EG/L/M	93*-ALL	93*-ALL
17	26270-92	COVER, oil pump	93-FA	93*-EA	--	--
	26262-80	SPRING, check valve	93*-ALL	93*-ALL	93*-ALL	93*-ALL
	26263-80	COVER SCREW, check & relief valves (2)	93*-ALL	93*-ALL	93*-ALL	93*-ALL
19	26273-92	GASKET, body (paper)	93*-ALL	93*-ALL	93*-ALL	93*-ALL
20	26276-92	GASKET, cover (paper)	93*-ALL	93*-ALL	93*-ALL	93*-ALL
21	26315-68A	DRIVE GEAR	93*-ALL	93*-ALL	93*-ALL	93*-ALL
22	26317-68A	IDLER GEAR	93*-ALL	93*-ALL	93*-ALL	93*-ALL
23	26326-62A	DRIVE IDLER GEAR	93*-ALL	93*-ALL	93*-ALL	93*-ALL
24	26327-68	SHAFT, idler gear	93*-ALL	93*-ALL	93*-ALL	93*-ALL
25	26328-74	DRIVE GEAR	93*-ALL	93*-ALL	93*-ALL	93*-ALL
26	26345-73	DRIVE GEAR, 24 T	93*-ALL	93*-ALL	93*-ALL	93*-ALL
27	26346-70	DRIVE SHAFT	93*-ALL	93*-ALL	93*-ALL	93*-ALL
28	26348-15	KEY, drive shaft (3)	93*-ALL	93*-ALL	93*-ALL	93*-ALL
29	26348-36	RETAINING RING, drive shaft	93*-ALL	93*-ALL	93*-ALL	93*-ALL
30	26400-82	VALVE, oil pump	93*-ALL	93*-ALL	93*-ALL	93*-ALL
31	45830-48	PLUG (2)	93*-ALL	93*-ALL	93*-ALL	93*-ALL
32	63533-41	FITTING, straight	--	--	93*-ALL	--
33	63554-90	FITTING 90 degree elbow	93*-ALL	93*-ALL	--	93*-ALL

FLT MODELS

FLHTC DJ
 FLTC-U DM
 FLHTC-U DP
 FLHS FA
 FLHR FD

FXR MODELS

FXR EA
 FXRS-SP EG
 FXLR EL
 FXRS-CON EM

SOFTAIL MODELS

FLSTC BJ
 FXSTC BK
 FXSTS BL
 FLSTF BM
 FLSTN BN

DYNA MODELS

FXDL GD
 FXDWG GE
 FXDS-CON GG

CARBURETOR

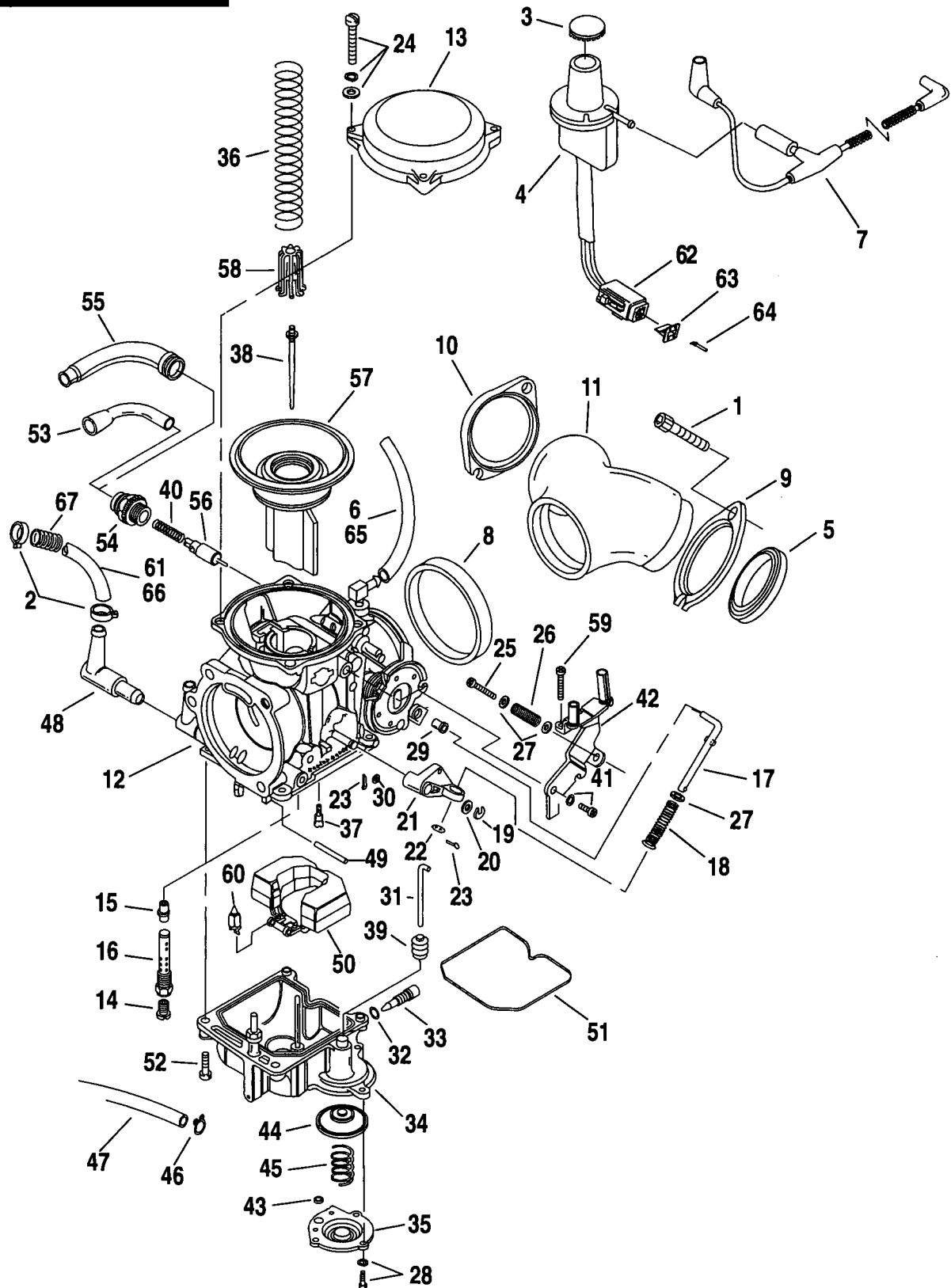

INDEX NO.	PART NO.	DESCRIPTION	FLT MODELS	FXR MODELS	SOFTAIL MODELS	DYNA MODELS
1	3201WA	SCREW (4)	93*-ALL	93*-ALL	93*-ALL	93*-ALL
2	10014	CLAMP (2)	93*-ALL	93*-ALL	93*-ALL	93*-ALL
3	11192	RETAINING RING	93*-ALL	93*-ALL	93*-ALL	93*-ALL
4	26555-91	VACUUM SWITCH	93-ALL	--	--	--
	26555-94	VACUUM SWITCH w/ #62,63 & 64	94*-ALL	--	--	--
	26566-91	VACUUM SWITCH	--	93*-ALL	93*-ALL	93*-ALL
5	26995-86A	SEAL, intake manifold (2)	93*-ALL	93*-ALL	93*-ALL	93*-ALL
6	26563-91A	VACUUM HOSE	93-ALL	93*-ALL	93*-ALL	93*-ALL
7	26563-94	VACUUM HOSE ASM.	94*-ALL	--	--	--
8	27002-89	SEAL RING	93*-ALL	93*-ALL	93*-ALL	93*-ALL
9	27009-86A	FLANGE, mounting -front	93*-ALL	93*-ALL	93*-ALL	93*-ALL
10	27010-86A	FLANGE, mounting - rear	93*-ALL	93*-ALL	93*-ALL	93*-ALL
11	27019-89	MANIFOLD	93*-ALL	93*-ALL	93*-ALL	93*-ALL
12	27026-92A	CARBURETOR (Cal. only)	93*-ALL	--	--	--
	27035-92A	CARBURETOR (Cal. only)	--	93*-ALL	93*-ALL	93*-ALL
	27038-92	CARBURETOR	--	E93*-ALL	E93*-ALL	E93-AL
	27039-92	CARBURETOR	E93*-ALL	--	--	--
	27206-93	CARBURETOR	--	L93*-ALL	L93*-ALL	L93*-ALL
	27207-93	CARBURETOR	L93*-ALL	--	--	--
13	27040-88	TOP, carburetor	93*-ALL	93*-ALL	93*-ALL	93*-ALL
14	27090-89	MAIN JET, 1.75 mm	93*-ALL	--	--	--
	27116-88	MAIN JET, 1.65 mm (Cal. only)	93*-ALL	93*-ALL	93*-ALL	93*-ALL
15	27100-88	NEEDLE JET	93*-ALL	93*-ALL	93*-ALL	93*-ALL
16	27101-88	NEEDLE JET HOLDER	93*-ALL	93*-ALL	93*-ALL	93*-ALL
17	27122-89	ROD	93*-ALL	93*-ALL	93*-ALL	93*-ALL
18	27123-89	SPRING	93*-ALL	93*-ALL	93*-ALL	93*-ALL
19	27124-89	E-CLIP	93*-ALL	93*-ALL	93*-ALL	93*-ALL
20	27125-89	WASHER	93*-ALL	93*-ALL	93*-ALL	93*-ALL
21	27126-89	LEVER	93*-ALL	93*-ALL	93*-ALL	93*-ALL
22	27127-89	WASHER	93*-ALL	93*-ALL	93*-ALL	93*-ALL
23	27128-89	PIN (2)	93*-ALL	93*-ALL	93*-ALL	93*-ALL
24	27129-88	SCREW, top (3)	93*-ALL	93*-ALL	93*-ALL	93*-ALL
25	27130-90	IDLE SCREW	93*-ALL	93*-ALL	93*-ALL	93*-ALL
26	27136-90	SPRING	93*-ALL	93*-ALL	93*-ALL	93*-ALL
27	27137-81	WASHER (3)	93*-ALL	93*-ALL	93*-ALL	93*-ALL
28	27146-89	SCREW W/WASHER (3)	93*-ALL	93*-ALL	93*-ALL	93*-ALL
29	27147-89	COLLAR	93*-ALL	93*-ALL	93*-ALL	93*-ALL
30	27148-89	WASHER	93*-ALL	93*-ALL	93*-ALL	93*-ALL
31	27156-89	ROD	93*-ALL	93*-ALL	93*-ALL	93*-ALL
32	27157-89	O-RING	93*-ALL	93*-ALL	93*-ALL	93*-ALL
33	27158-89	DRAIN SCREW	93*-ALL	93*-ALL	93*-ALL	93*-ALL
34	27159-92	FLOAT CHAMBER ASM.	93*-ALL	93*-ALL	93*-ALL	93*-ALL
35	27160-89	PUMP HOUSING	93*-ALL	93*-ALL	93*-ALL	93*-ALL
36	27162-89	SPRING	93*-ALL	93*-ALL	93*-ALL	93*-ALL
37	27171-89	SLOW JET	L93*-ALL	--	--	--
	27281-92	SLOW JET	E93-ALL	93*-ALL	93*-ALL	93*-ALL

FLT MODELS

FLHTC DJ
 FLTC-U DM
 FLHTC-U DP
 FLHS FA
 FLHR FD

FXR MODELS

FXR EA
 FXRS-SP EG
 FXLR EL
 FXRS-CON EM

SOFTAIL MODELS

FLSTC BJ
 FXSTC BK
 FXSTS BL
 FLSTF BM
 FLSTN BN

DYNA MODELS

FXDL GD
 FXDWG GE
 FXDS-CON GG

CARBURETOR

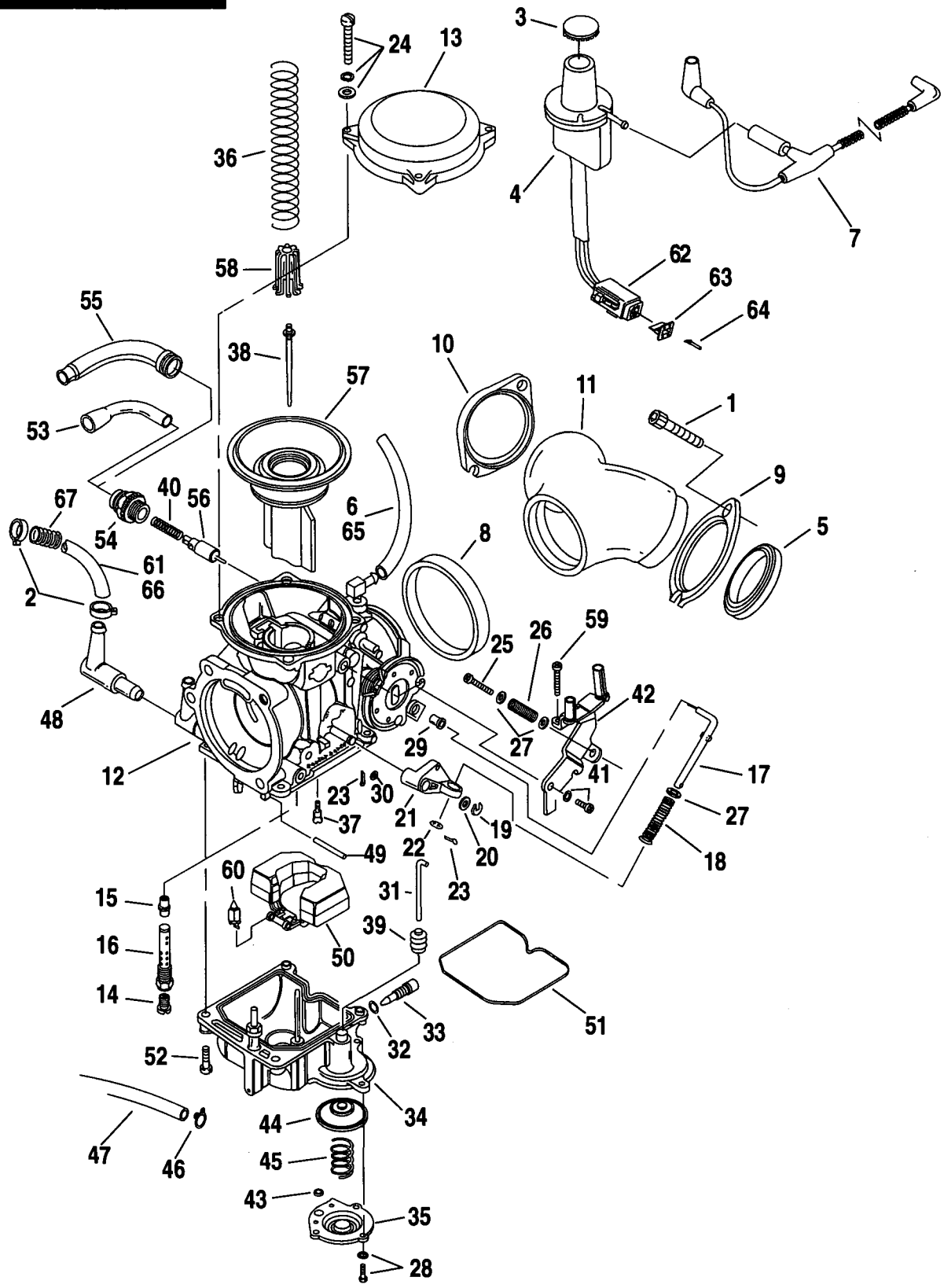

INDEX NO.	PART NO.	DESCRIPTION	FLT MODELS	FXR MODELS	SOFTAIL MODELS	DYNA MODELS
38	27184-92	JET NEEDLE	93*-ALL	--	--	--
	27186-92	JET NEEDLE	--	93*-ALL	93*-ALL	93*-ALL
	27280-92	JET NEEDLE (Cal. only)	--	93*-ALL	93*-ALL	93*-ALL
39	27311-76	CAP, accelerator pump	93*-ALL	93*-ALL	93*-ALL	93*-ALL
40	27315-88A	SPRING	93*-ALL	93*-ALL	93*-ALL	93*-ALL
41	27317-88	SCREW	93*-ALL	93*-ALL	93*-ALL	93*-ALL
42	27339-90	BRACKET, throttle cables	--	93*-ALL	93*-ALL	93*-ALL
	27340-90	BRACKET, throttle cables	93*-ALL	--	--	--
43	27360-76	O-RING	93*-ALL	93*-ALL	93*-ALL	93*-ALL
44	27361-76	DIAPHRAM, accelerator pump	93*-ALL	93*-ALL	93*-ALL	93*-ALL
45	27362-76	SPRING, diaphragm	93*-ALL	93*-ALL	93*-ALL	93*-ALL
46	27368-76	CLIP, overflow hose	93*-ALL	93*-ALL	93*-ALL	93*-ALL
47	27369-76	HOSE, overflow w/#46	93*-ALL	93*-ALL	93*-ALL	93*-ALL
48	27371-76	FITTING	93*-ALL	93*-ALL	93*-ALL	93*-ALL
49	27575-88	PIN	93*-ALL	93*-ALL	93*-ALL	93*-ALL
50	27576-92	FLOAT	93*-ALL	93*-ALL	93*-ALL	93*-ALL
51	27577-92	O-RING	93*-ALL	93*-ALL	93*-ALL	93*-ALL
52	27579-88A	SCREW (4)	93*-ALL	93*-ALL	93*-ALL	93*-ALL
53	27580-88	CABLE GUIDE	93*-ALL	93*-ALL	93*-ALL	93*-ALL
54	27581-88	STARTER CAP	93*-ALL	93*-ALL	93*-ALL	93*-ALL
55	27582-88	CABLE SEALING CAP	93*-ALL	93*-ALL	93*-ALL	93*-ALL
56	27583-88	STARTER VALVE	93*-ALL	93*-ALL	93*-ALL	93*-ALL
57	27585-88	VACUUM PISTON	93*-ALL	93*-ALL	93*-ALL	93*-ALL
58	27586-88	SPRING SEAT	93*-ALL	93*-ALL	93*-ALL	93*-ALL
59	27587-88	SCREW	93*-ALL	93*-ALL	93*-ALL	93*-ALL
60	27886-78A	VALVE W/CLIP	93*-ALL	93*-ALL	93*-ALL	93*-ALL
61	62356-92	FUEL HOSE	93*-ALL	--	--	--
62	72112-94BK	PLUG, two-way socket	94*-ALL	--	--	--
63	72152-94	SOCKET LOCK, secondary. two-way	94*-ALL	--	--	--
64	72191-94	TERMINAL, socket (2)	94*-ALL	--	--	--

NOTE: Hose is sold only in bulk length under the following part numbers. Cut to length.

65	26570-84	HOSE, 3/16 I.D. (10 ft. lg.) (black)	--	93*-ALL	93*-ALL	93*-ALL
66	63501-68	HOSE, 1/4 I.D. (25 ft. lg.)(black)	--	93*-ALL	93*-ALL	93*-ALL
67	63505-84	INSULATOR, 1/2 I.D. (nylon) (8 ft. lg.)	93*-ALL	93*-ALL	93*-ALL	93*-ALL

H-D INTERNATIONAL ONLY

11	26994-90	MANIFOLD (HDI only)	--	93*-ALL	93*-ALL	93*-ALL
12	27039-92	CARBURETOR (HDI only)	L93*-ALL	--	--	--
37	27281-91	SLOW JET (HDI only)	L93*-ALL	--	--	--

FLT MODELS

FLHTC DJ
 FLTC-U DM
 FLHTC-U DP
 FLHS FA
 FLHR FD

FXR MODELS

FXR EA
 FXRS-SP EG
 FXLR EL
 FXRS-CON EM

SOFTAIL MODELS

FLSTC BJ
 FXSTC BK
 FXSTS BL
 FLSTF BM
 FLSTN BN

DYNA MODELS

FXDL GD
 FXDWG GE
 FXDS-CON GG

AIR CLEANER & ENRICHENER

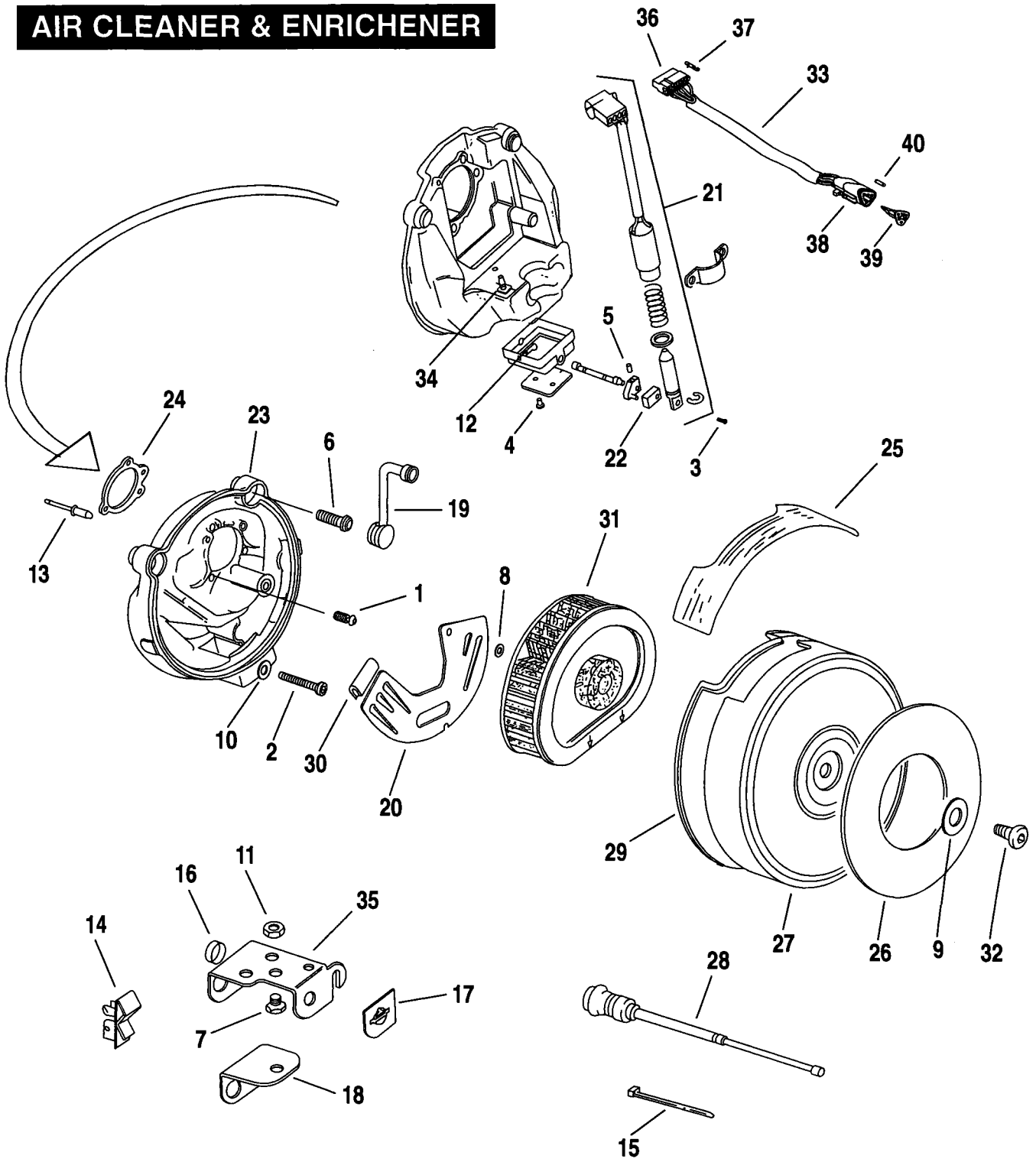

INDEX NO.	PART NO.	DESCRIPTION	FLT MODELS	FXR MODELS	SOFTAIL MODELS	DYNA MODELS
1	864	SCREW (3)	93*-ALL	93*-ALL	93*-ALL	93*-ALL
2	1795A	SCREW (Cal. only)(2)	93*-ALL	93*-ALL	93*-ALL	93*-ALL
3	2711	SCREW (Cal. only)	93*-ALL	93*-ALL	93*-ALL	93*-ALL
4	2737	SCREW (Cal. only)(2)	93*-ALL	93*-ALL	93*-ALL	93*-ALL
5	3221	SET SCREW (Cal. only)	93*-ALL	93*-ALL	93*-ALL	93*-ALL
6	3577	SCREW, breather (2)	93*-ALL	93*-ALL	93*-ALL	93*-ALL
7	4713W	BOLT (2)	93*-ALL	--	93*-ALL	93*-ALL
8	6048W	WASHER	93*-ALL	93*-ALL	93*-ALL	93*-ALL
9	6109	WASHER	93*-ALL	93*-ALL	93*-ALL	93*-ALL
10	6253W	WASHER (Cal. only)(2)	93*-ALL	93*-ALL	93*-ALL	93*-ALL
11	7601	NUT, flange (2)	93*-ALL	--	93*-ALL	93*-ALL
12	8535	RIVET (Cal. only)(2)	93*-ALL	93*-ALL	93*-ALL	93*-ALL
13	8625	POP RIVET	93*-ALL	93*-ALL	93*-ALL	93*-ALL
14	9894	CLIP, ground	--	--	93*-ALL	--
15	10006	CABLE STRAP	93*-ALL	93*-ALL	93*-ALL	--
	10065	CABLE STRAP	93*-ALL	--	--	--
16	11460	GROMMET	93*-ALL	93*-ALL	93*-ALL	93*-ALL
17	14340-90	DECAL	--	--	--	93*-ALL
18	16249-92	BRACKET, enrichment cable	--	93*-ALL	--	--
19	24922-93	BREATHER CONNECTOR (2)	93*-ALL	93*-ALL	93*-ALL	93*-ALL
20	28823-89	BAFFLE PLATE ASSEMBLY (Cal. only)	93*-ALL	93*-ALL	93*-ALL	93*-ALL
	29068-89	BAFFLE PLATE	93*-ALL	93*-ALL	93*-ALL	93*-ALL
21	28841-89	SOLENOID (Cal. only)	93*-ALL	93*-ALL	93*-ALL	93*-ALL
22	28842-89	LINK (Cal. only)	93*-ALL	93*-ALL	93*-ALL	93*-ALL
23	29017-92	BACKPLATE ASSEMBLY (Cal. only)	93*-ALL	93*-ALL	93*-ALL	93*-ALL
	29134-92	BACKPLATE ASSEMBLY	93*-ALL	93*-ALL	93*-ALL	93*-ALL
24	29059-88A	GASKET	93*-ALL	93*-ALL	93*-ALL	93*-ALL
25	29126-90	SAFETY LABEL	93*-ALL	93*-ALL	93*-ALL	93*-ALL
26	29142-91	TRIM, - "DYNA LOW RIDER™"	--	--	--	93*-GD
	29150-93	TRIM, - "DYNA WIDE GLIDE"	--	--	--	93*-GE
	29161-86	TRIM, - "HERITAGE™ SOFTAIL"	--	--	93*-BJ/N	--
	29164-87	TRIM, - "SPORT GLIDE™ CUSTOM"	--	93*-EL	--	--
	29166-86	TRIM, - "LOW RIDER™ SPORT"	--	93*-EG	--	--
	29169-84	TRIM, - "SOFTAIL"	--	--	93*-B/K	--
	29181-88	TRIM, - "SPRINGER SOFTAIL™"	--	--	93*-BL	--
	29256-90	TRIM, - "FAT BOY"	--	--	93*-BM	--
	29278-86	TRIM, - "TOUR GLIDE™"	93*-DM	--	--	--
	29279-86	TRIM, - "ELECTRA GUIDE™"	93*-DJ/P; 93*-FA	--	--	--
	29292-94	TRIM, - "ROAD KING™"	94*-FD	--	--	--
	29307-94	TRIM, - "DYNA GLIDE™ CONVERTIBLE"	--	--	--	94*-GG
	90358-89	TRIM, - "LOW RIDER CONVERTIBLE"	--	93*-EM	--	--

FLT MODELS

FLHC DJ
FLTC-U DM
FLHC-U DP
FLHS FA
FLHR FD

FXR MODELS

FXR EA
FXRS-SP EG
FXLR EL
FXRS-CON EM

SOFTAIL MODELS

FLSTC BJ
FXSTC BK
FXSTS BL
FLSTF BM
FLSTN BN

DYNA MODELS

FXDL GD
FXDWG GE
FXDS-CON GG

AIR CLEANER & ENRICHENER

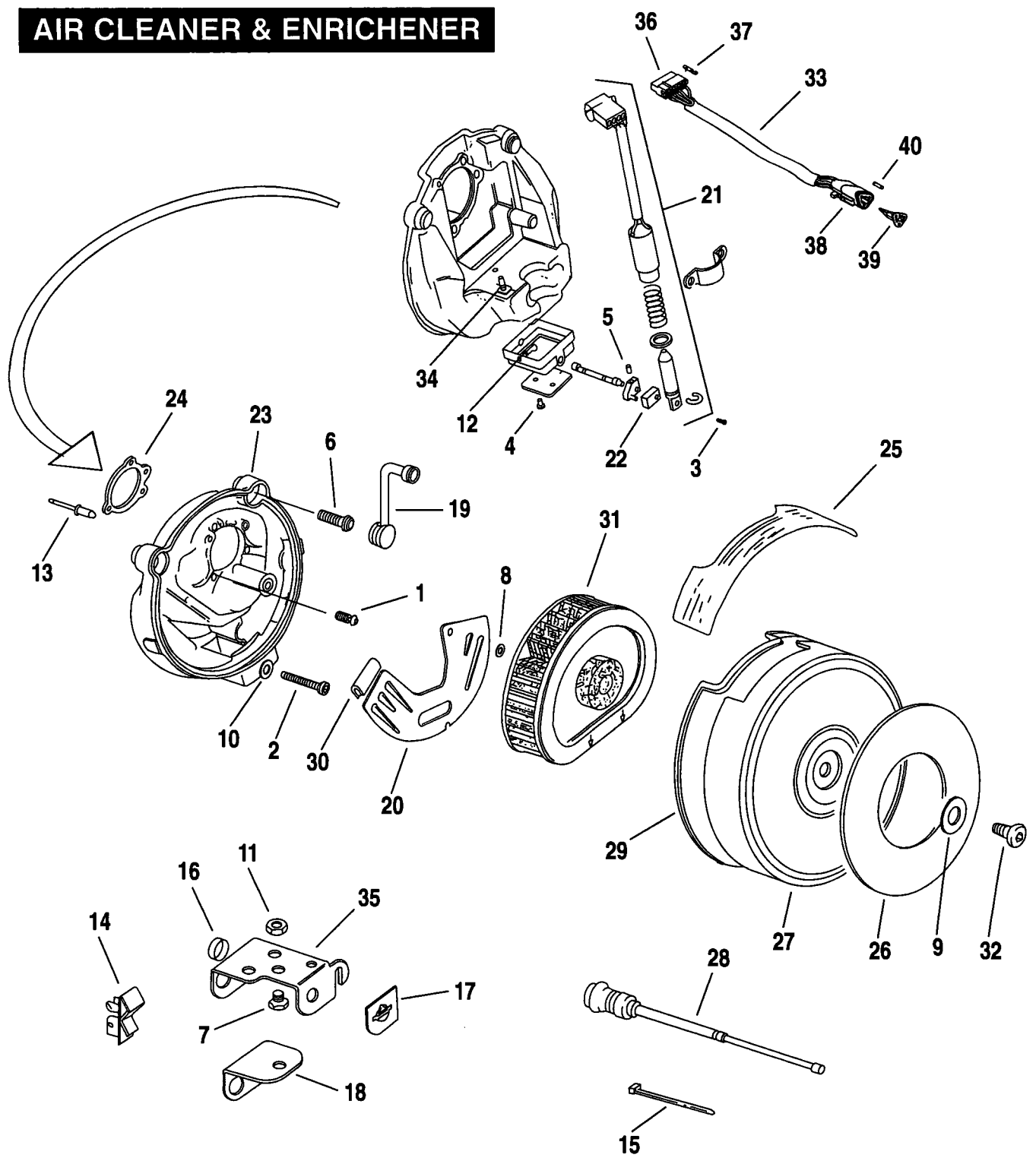

INDEX NO.	PART NO.	DESCRIPTION	FLT MODELS	FXR MODELS	SOFTAIL MODELS	DYNA MODELS
27	29165-89	COVER, air cleaner	93*-ALL	93*-ALL	93*-ALL	93*-ALL
28	29229-88A	CABLE, enrichment	93*-ALL	93*-ALL	93*-ALL	93*-ALL
29	29252-89	MOLDING	93*-ALL	93*-ALL	93*-ALL	93*-ALL
30	29258-91	MOLDING	93*-ALL	93*-ALL	93*-ALL	93*-ALL
31	29259-91A	FILTER ELEMENT	93*-ALL	93*-ALL	93*-ALL	93*-ALL
32	29269-83A	SCREW	93-ALL	93-ALL	93-ALL	93-ALL
	29283-93	SCREW	94*-ALL	94*-ALL	94*-ALL	94*-ALL
33	32441-92	WIRING HARNESS, solenoid (Cal. only)	93-ALL	--	--	--
	32441-94	WIRING HARNESS, solenoid w/ #36, 37, 38,39 & 40 (Cal. only)	94*-DJ/P;FD	--	--	--
	32442-93	WIRING HARNESS, solenoid (Cal. only)	--	--	93*-ALL	--
	32443-92	WIRING HARNESS, solenoid (Cal. only)	--	93*-ALL	--	--
	70963-92	WIRING HARNESS, solenoid (Cal. only)	--	--	--	93*-ALL
34	61095-92	FITTING (Cal. only)	93*-ALL	93*-ALL	93*-ALL	93*-ALL
35	69126-92	BRACKET, enrichment cable	93*-ALL	--	93*-ALL	93*-ALL
36	70292-89	CONNECTOR, four pin	94*-DJ/P;FD	--	--	--
37	72038-71	SOCKET, single pin (4)	94*-DJ/P;FD	--	--	--
38	72113-94BK	PLUG, 3-way socket	94*-DJ/P;FD	--	--	--
39	72153-94	SOCKET LOCK, sec. 3-way	94*-DJ/P;FD	--	--	--
40	72191-94	TERMINAL, socket (3)	94*-DJ/P;FD	--	--	--
H-D INTERNATIONAL ONLY						
20	29070-89B	BAFFLE PLATE	93*-ALL	93*-ALL	93*-ALL	93*-ALL

FLT MODELS

FLHTC DJ
 FLTC-U DM
 FLHTC-U DP
 FLHS FA
 FLHR FD

FXR MODELS

FXR EA
 FXRS-SP EG
 FXLR EL
 FXRS-CON EM

SOFTAIL MODELS

FLSTC BJ
 FXSTC BK
 FXSTS BL
 FLSTF BM
 FLSTN BN

DYNA MODELS

FXDL GD
 FXDWG GE
 FXDS-CON GG

ALTERNATOR & REGULATOR

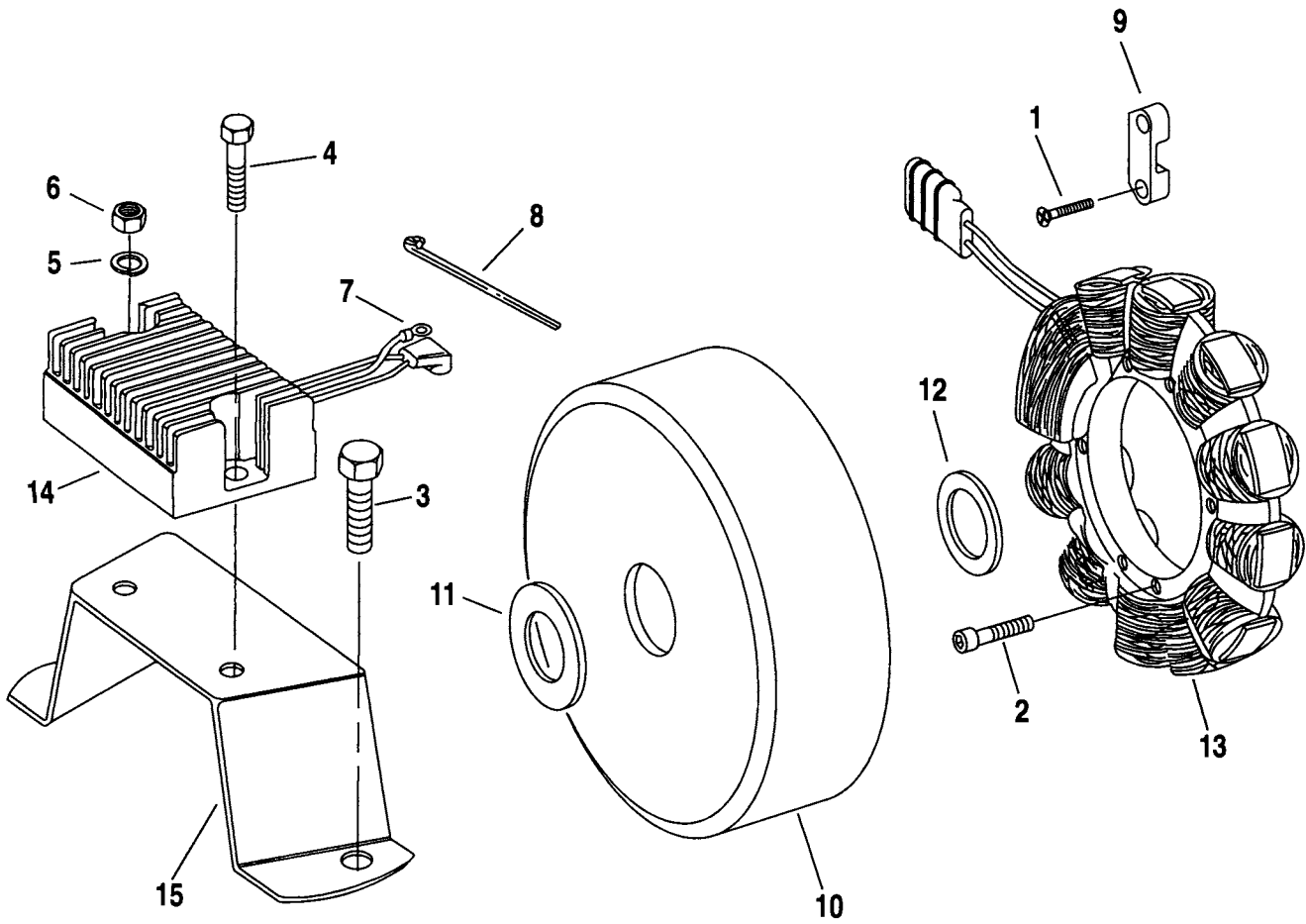

INDEX NO.	PART NO.	DESCRIPTION	FLT MODELS	FXR MODELS	SOFTAIL MODELS	DYNA MODELS
1	2216W	SCREW (2)	93*-ALL	93*-ALL	93*-ALL	93*-ALL
2	2720	SCREW (4)	93*-ALL	93*-ALL	93*-ALL	93*-ALL
3	4328	BOLT (2)	93*-ALL	93*-ALL	--	--
4	939	SCREW, right	--	93*-ALL	--	--
	4329	SCREW (2 - FLT, DYNA)	93*-ALL	93*-ALL	--	93*-ALL
5	7124	LOCKWASHER (2 - SOFTAIL)	--	93*-ALL	93*-ALL	--
6	7688	LOCKNUT (2)	--	--	93*-ALL	--
7	9866	WIRE TERMINAL, ring type	93*-ALL	93*-ALL	93*-ALL	93*-ALL
8	10006	CABLE STRAP	93*-ALL	--	93*-ALL	--
9	29954-71A	RETAINER, alternator plug	93*-ALL	93*-ALL	93*-ALL	93*-ALL
10	29957-81B	ROTOR ASSEMBLY	93*-ALL	93*-ALL	93*-ALL	93*-ALL
11	29960-91	SPACER	93*-ALL	93*-ALL	--	--
12	29961-85	SPACER	93*-ALL	93*-ALL	93*-ALL	93*-ALL
13	29970-88B	STATOR	93*-ALL	93*-ALL	93*-ALL	93*-ALL
14	74519-88	REGULATOR	93*-ALL	93*-ALL	93*-ALL	93*-ALL
15	74529-79A	BRACKET, regulator mounting	93*-ALL	93*-ALL	--	--

FLT MODELS

FLHTC DJ
 FLTC-U DM
 FLHTC-U DP
 FLHS FA
 FLHR FD

FXR MODELS

FXR EA
 FXRS-SP EG
 FXLR EL
 FXRS-CON EM

SOFTAIL MODELS

FLSTC BJ
 FXSTC BK
 FXSTS BL
 FLSTF BM
 FLSTN BN

DYNA MODELS

FXDL GD
 FXDWG GE
 FXDS-CON GG

ELECTRONIC IGNITION SYSTEM

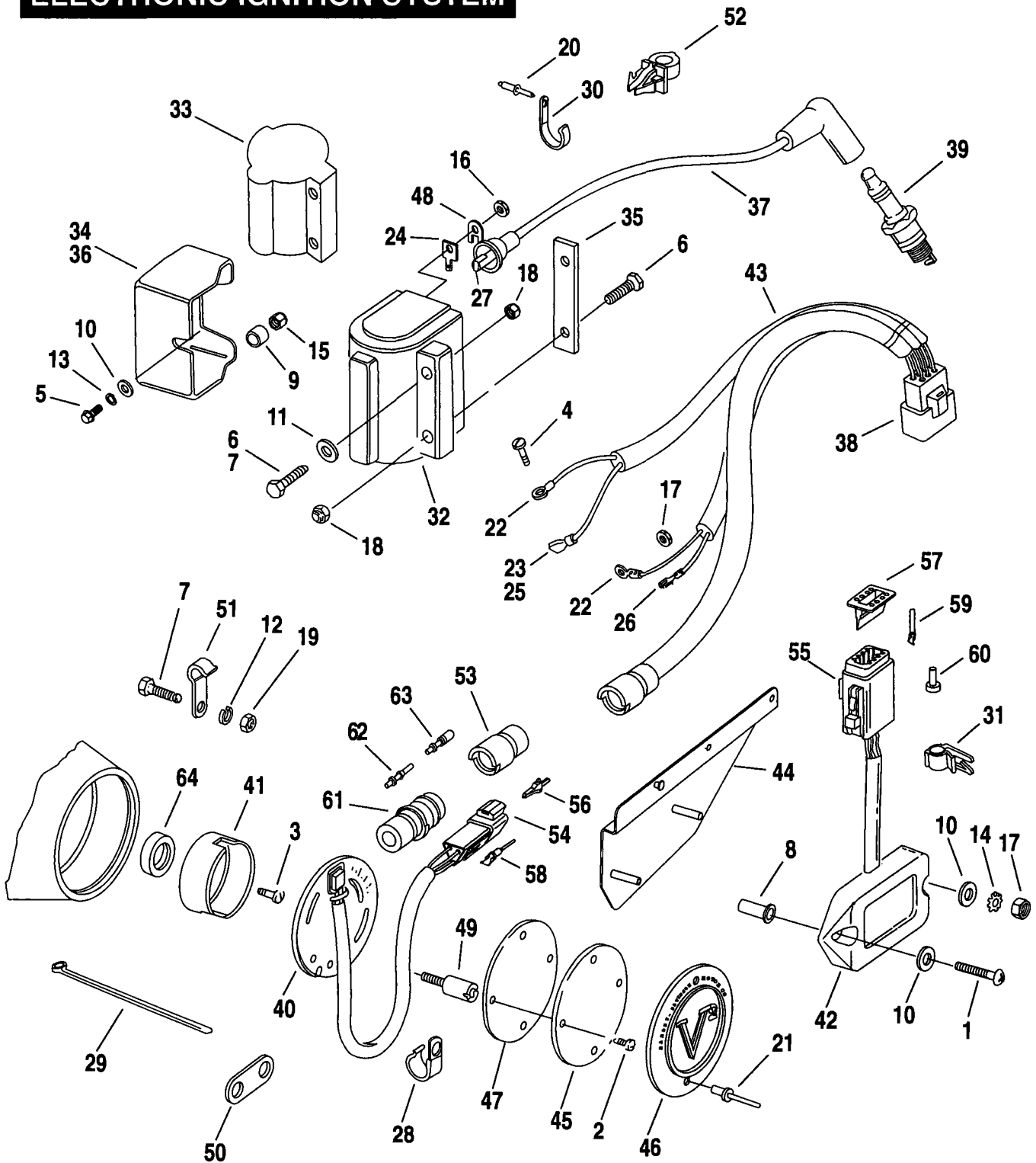

INDEX NO.	PART NO.	DESCRIPTION	FLT MODELS	FXR MODELS	SOFTAIL MODELS	DYNA MODELS
1	933	SCREW (2)	--	--	93*-ALL	--
2	1601	SCREW (2)	93*-ALL	93*-ALL	93*-ALL	93*-ALL
3	2611B	SCREW	93*-ALL	93*-ALL	93*-ALL	93*-ALL
4	2731W	SCREW	--	93*-ALL	93*-ALL	--
	4091	SCREW	93-ALL	--	--	93-ALL
5	3473	SCREW (2;3-DYNA)	--	93*-ALL	--	93*-ALL
	3602	SCREW (2)	--	--	93*-ALL	--
6	3993	BOLT (2)	93*-ALL	--	93*-ALL	--
	4741A	SCREW (2)	--	--	--	93*-ALL
7	4718A	SCREW (3)	--	93*-ALL	--	--
8	5207	WELL NUT (2)	--	--	93*-ALL	--
9	6058	SPACER (3)	93*-ALL	--	--	93*-ALL
10	6716	WASHER (2)	93*-ALL	93*-ALL	93*-ALL	93*-ALL
11	7036	LOCKWASHER (2)	94*-ALL	--	93*-ALL	--
12	7041	LOCKWASHER	--	--	93*-ALL	--
13	7069	LOCKWASHER (2)	--	--	--	93*-ALL
	7118	LOCKWASHER (2)	--	93*-ALL	--	--
14	7220	LOCKWASHER (2)	--	93*-ALL	--	--
15	7626W	NUT (3)	--	--	--	93*-ALL
16	7629	NUT (2)	93*-ALL	93*-ALL	93*-ALL	--
17	7634	NUT (brass) (2)	93*-ALL	93*-ALL	--	93*-ALL
18	7686	LOCKNUT (2)	93-ALL	93*-ALL	93*-ALL	--
19	7753	NUT	--	--	93*-ALL	--
20	8483	RIVET, blind	93*-ALL	--	--	--
21	8699	RIVET, timer cover (2)	93*-ALL	93*-ALL	93*-ALL	93*-ALL
22	9857	TERMINAL, ring type (2-FLT, FXR)	93-ALL	93*-ALL	93*-ALL	93*-ALL
23	9863	TERMINAL, female spade type	--	--	93*-ALL	93*-ALL
24	9881	ADAPTOR, terminal	--	--	93*-ALL	--
25	9900	TERMINAL, female spade type	93-ALL	93*-ALL	93*-ALL	--
26	9907	TERMINAL, female spade type	93-ALL	93*-ALL	93*-ALL	93*-ALL
27	9908	TERMINAL, spark plug cable	--	--	93*-ALL	--
28	9951	CLIP, sensor wire	--	--	--	93*-ALL
	10003	CLAMP	93-ALL	--	93*-ALL	--
29	10065	CABLE STRAP	--	93*-ALL	93*-ALL	93*-ALL
	10073	CABLE STRAP	--	--	94*-ALL	--

FLT MODELS

FLHTC DJ
 FLTC-U DM
 FLHTC-U DP
 FLHS FA
 FLHR FD

FXR MODELS

FXR EA
 FXRS-SP EG
 FXLR EL
 FXRS-CON EM

SOFTAIL MODELS

FLSTC BJ
 FXSTC BK
 FXSTS BL
 FLSTF BM
 FLSTN BN

DYNA MODELS

FXDL GD
 FXDWG GE
 FXDS-CON GG

ELECTRONIC IGNITION SYSTEM

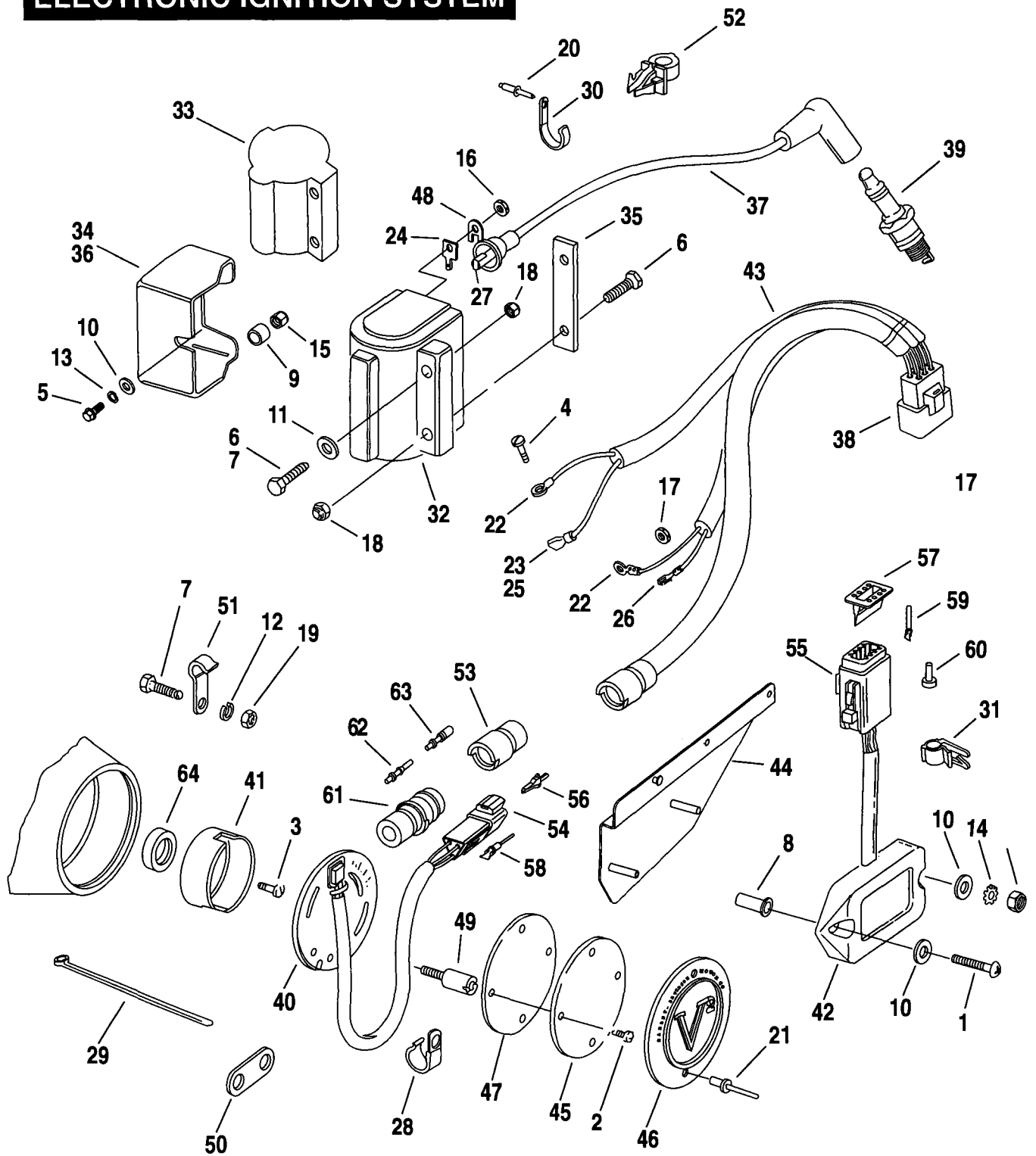

ELECTRONIC IGNITION SYSTEM (CONT'D)

FB10-2

INDEX NO.	PART NO.	DESCRIPTION	FLT MODELS	FXR MODELS	SOFTAIL MODELS	DYNA MODELS
30	10092	CLAMP	93*-ALL	--	--	--
31	10110	CLIP, module wires	93-ALL	--	--	--
32	31614-83A	IGNITION COIL	93*-ALL	93*-ALL	93*-ALL	93*-ALL
33	31625-82	COVER, coil	--	93*-ALL	--	--
34	31640-91	COVER, coil (chrome)	--	--	--	93*-ALL
35	31727-85	NUT PLATE	94*-ALL	--	93*-ALL	93*-ALL
36	31800-78A	IGNITION COIL COVER KIT (chrome)	--	--	93*-ALL	--
37	31981-65B	SPARK PLUG CABLE, front cylinder	--	--	--	93*-ALL
	31983-71A	SPARK PLUG CABLE, rear cylinder	--	--	93*-ALL	93*-ALL
	31985-91	SPARK PLUG CABLE, front cylinder	--	--	93*-ALL	--
	31992-91	SPARK PLUG CABLE, rear cylinder	93*-ALL	--	--	--
	31994-91	SPARK PLUG CABLE, front cylinder	93*-ALL	--	--	--
	70187-82	SPARK PLUG CABLE (2)	--	93*-ALL	--	--
38	31998-91	INSULATOR, receptacle housing	93-ALL	93*-ALL	93*-ALL	93*-ALL
39	32311-83	SPARK PLUG, No. 5R6A - 0.40 gap (2)	93*-ALL	93*-ALL	93*-ALL	93*-ALL
40	32400-80A	SENSOR ASSEMBLY w/o receptacle	93-ALL	93*-ALL	93*-ALL	--
	32400-94	SENSOR ASSEMBLY w/ #58	94*-ALL	--	--	--
	32404-90	SENSOR ASSEMBLY w/o receptacle	--	--	--	93*-ALL
41	32402-83	ROTOR	93*-ALL	93*-ALL	93*-ALL	93*-ALL
42	32405-91A	IGNITION MODULE	93-ALL	93*-ALL	93*-ALL	93*-ALL
	32426-94	IGNITION MODULE w/ #55,57,59 & 60	94*-ALL	--	--	--
43	32435-91	WIRING HARNESS, ignition module	93-ALL	--	--	--
	70339-91A	WIRING HARNESS, ignition module	--	--	--	93*-ALL
44	32451-94	BRACKET, ignition module	94*-ALL	--	--	--
45	32504-80	TIMER COVER, inner	93*-ALL	93*-ALL	93*-ALL	93*-ALL
46	32524-83	TIMER COVER	93*-ALL	93*-ALL	93*-ALL	93*-ALL
47	32591-80	GASKET, timer cover	93*-ALL	93*-ALL	93*-ALL	93*-ALL
48	32604-78	TERMINAL ADAPTOR	93-ALL	--	--	--
49	32606-82	SCREW, timer plate (2)	93*-ALL	93*-ALL	93*-ALL	93*-ALL
50	38711-93	RETAINER, sensor wire	--	--	93*-ALL	--
51	67075-57A	BRACKET, spark plug cable	--	--	93*-ALL	--
52	70345-84	RETAINER, coil wire to frame (2)	94*-ALL	--	--	--
53	72051-77	RECEPTACLE - three-way	93-ALL	93*-ALL	93*-ALL	93*-ALL
54	72103-94BK	RECEPTACLE - three-way	94*-ALL	--	--	--
55	72118-94BK	PLUG, eight-way socket	94*-ALL	--	--	--
56	72143-94	SECONDARY LOCK, three-way receptacle	94*-ALL	--	--	--
57	72158-94	SOCKET LOCK, eight-way	94*-ALL	--	--	--
58	72190-94	TERMINAL, pin (3)	94*-ALL	--	--	--
59	72191-94	TERMINAL, socket (7)	94*-ALL	--	--	--
60	72195-94	SEAL PIN	94*-ALL	--	--	--
61	74521-77	PLUG, three-way - sensor	93-ALL	93*-ALL	93*-ALL	93*-ALL
62	74536-77A	PIN, single socket (10)	93-ALL	93*-ALL	93*-ALL	93*-ALL
63	74539-77A	SOCKET, single pin (10)	93-ALL	93*-ALL	93*-ALL	93*-ALL
64	83162-51	OIL SEAL	93*-ALL	93*-ALL	93*-ALL	93*-ALL

FLT MODELS

FLHTC DJ
 FLTC-U DM
 FLHTC-U DP
 FLHS FA
 FLHR FD

FXR MODELS

FXR EA
 FXRS-SP EG
 FXLR EL
 FXRS-CON EM

SOFTAIL MODELS

FLSTC BJ
 FXSTC BK
 FXSTS BL
 FLSTF BM
 FLSTN BN

DYNA MODELS

FXDL GD
 FXDWG GE
 FXDS-CON GG

STARTER MOTOR

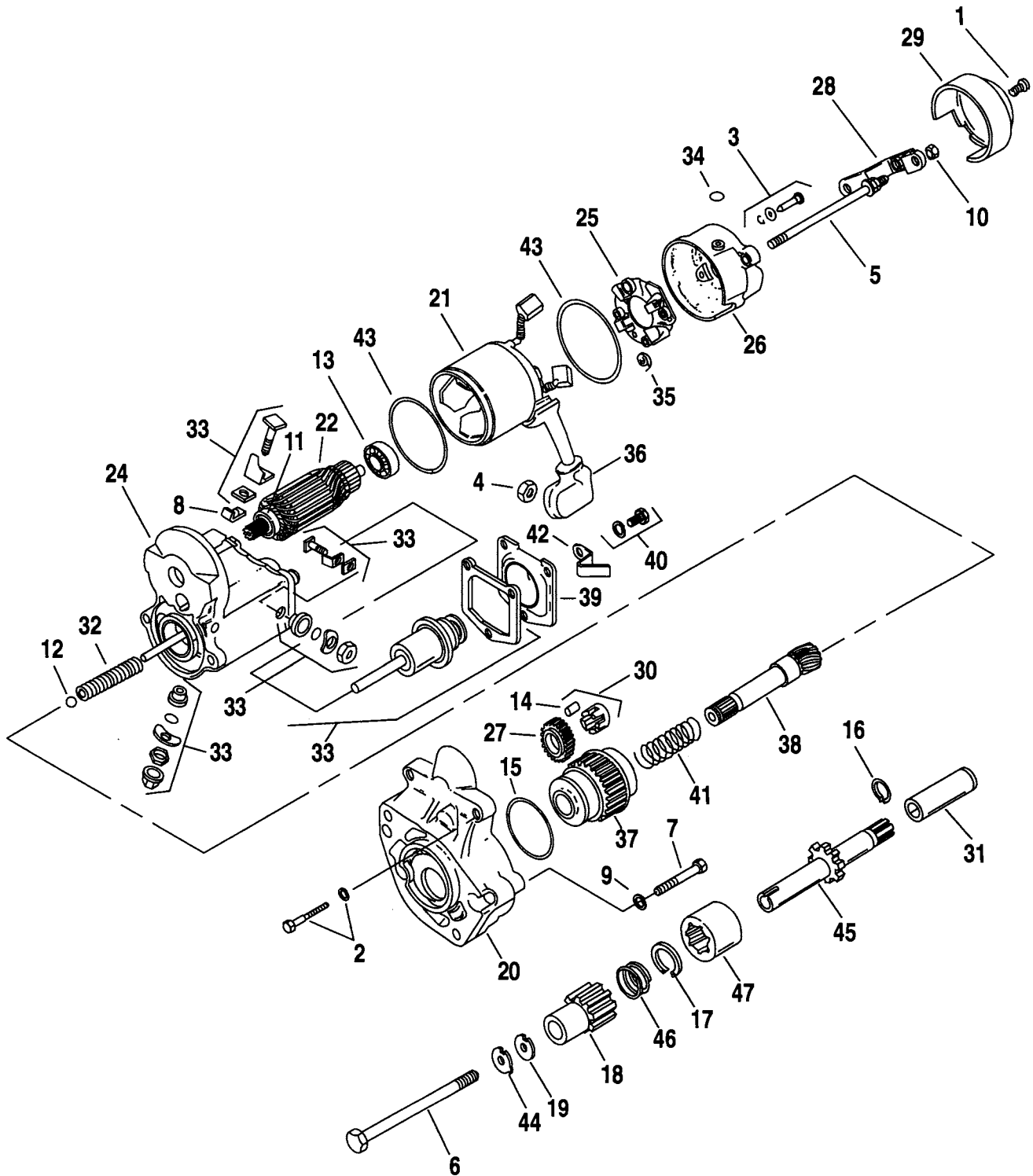

STARTER MOTOR

FB11-1

INDEX NO.	PART NO.	DESCRIPTION	FLT MODELS	FXR MODELS	SOFTAIL MODELS	DYNA MODELS
1	925	SCREW, cover	93*-ALL	93*-ALL	93*-ALL	93*-ALL
2	928	BOLT, starter (2)	93*-ALL	93*-ALL	93*-ALL	93*-ALL
3	929	SCREW with O-Ring (2)	93*-ALL	93*-ALL	93*-ALL	93*-ALL
4	3403	NUT, flange	93*-ALL	93*-ALL	93*-ALL	93*-ALL
5	3559	BOLT, starter (2)	93*-ALL	93*-ALL	93*-ALL	93*-ALL
6	4325	SCREW	93-ALL	93-ALL	93-ALL	93-ALL
	4358	SCREW	94*-ALL	94*-ALL	94*-ALL	94*-ALL
7	4326A	SCREW (2)	93*-ALL	93*-ALL	93*-ALL	93*-ALL
8	6217	WASHER	93*-ALL	93*-ALL	93*-ALL	93*-ALL
9	7041	LOCKWASHER (2)	93*-ALL	93*-ALL	93*-ALL	93*-ALL
10	7838	NUT, keps (2)	93*-ALL	93*-ALL	93*-ALL	93*-ALL
11	8871	BALL BEARING	93*-ALL	93*-ALL	93*-ALL	93*-ALL
12	8879	BALL	93*-ALL	93*-ALL	93*-ALL	93*-ALL
13	8883	BALL BEARING	93*-ALL	93*-ALL	93*-ALL	93*-ALL
14	9077	CLUTCH ROLLER (5)	93*-ALL	93*-ALL	93*-ALL	93*-ALL
15	11116	O-RING	93*-ALL	93*-ALL	93*-ALL	93*-ALL
16	11182	RETAINING RING	93*-ALL	93*-ALL	93*-ALL	93*-ALL
17	11183	RETAINING RING	93-ALL	93-ALL	93-ALL	93-ALL
	11248	RETAINING RING	94*-ALL	94*-ALL	94*-ALL	94*-ALL
18	31342-93	PINION GEAR	93-ALL	93-ALL	93-ALL	93-ALL
	31342-94	PINION GEAR	94*-ALL	94*-ALL	94*-ALL	94*-ALL
19	31430-93	WASHER, thrust	93-ALL	93-ALL	93-ALL	93-ALL
	31430-94	WASHER, thrust	94*-ALL	94*-ALL	94*-ALL	94*-ALL
20	31510-90	HOUSING, starter	93*-ALL	93*-ALL	93*-ALL	93*-ALL
21	31514-90	YOKE ASSEMBLY, starter	93*-ALL	93*-ALL	93*-ALL	93*-ALL
22	31515-90	ARMATURE ASSEMBLY	93*-ALL	93*-ALL	93*-ALL	93*-ALL
	31516-90	CLUTCH ASSEMBLY, starter w/ #37, 38, & 41	93-ALL	93-ALL	93-ALL	93-ALL
	31516-94	CLUTCH ASSEMBLY, starter w/ #37, 38, & 41	94*-ALL	94*-ALL	94*-ALL	94*-ALL
24	31517-90	SWITCH ASSEMBLY, magnetic w/ housing, #8, 33, 39, & 42	93*-ALL	93*-ALL	93*-ALL	93*-ALL

FLT MODELS

FLHTC DJ
 FLTC-U DM
 FLHTC-U DP
 FLHS FA
 FLHR FD

FXR MODELS

FXR EA
 FXRS-SP EG
 FXLR EL
 FXRS-CON EM

SOFTAIL MODELS

FLSTC BJ
 FXSTC BK
 FXSTS BL
 FLSTF BM
 FLSTN BN

DYNA MODELS

FXDL GD
 FXDWG GE
 FXDS-CON GG

STARTER MOTOR

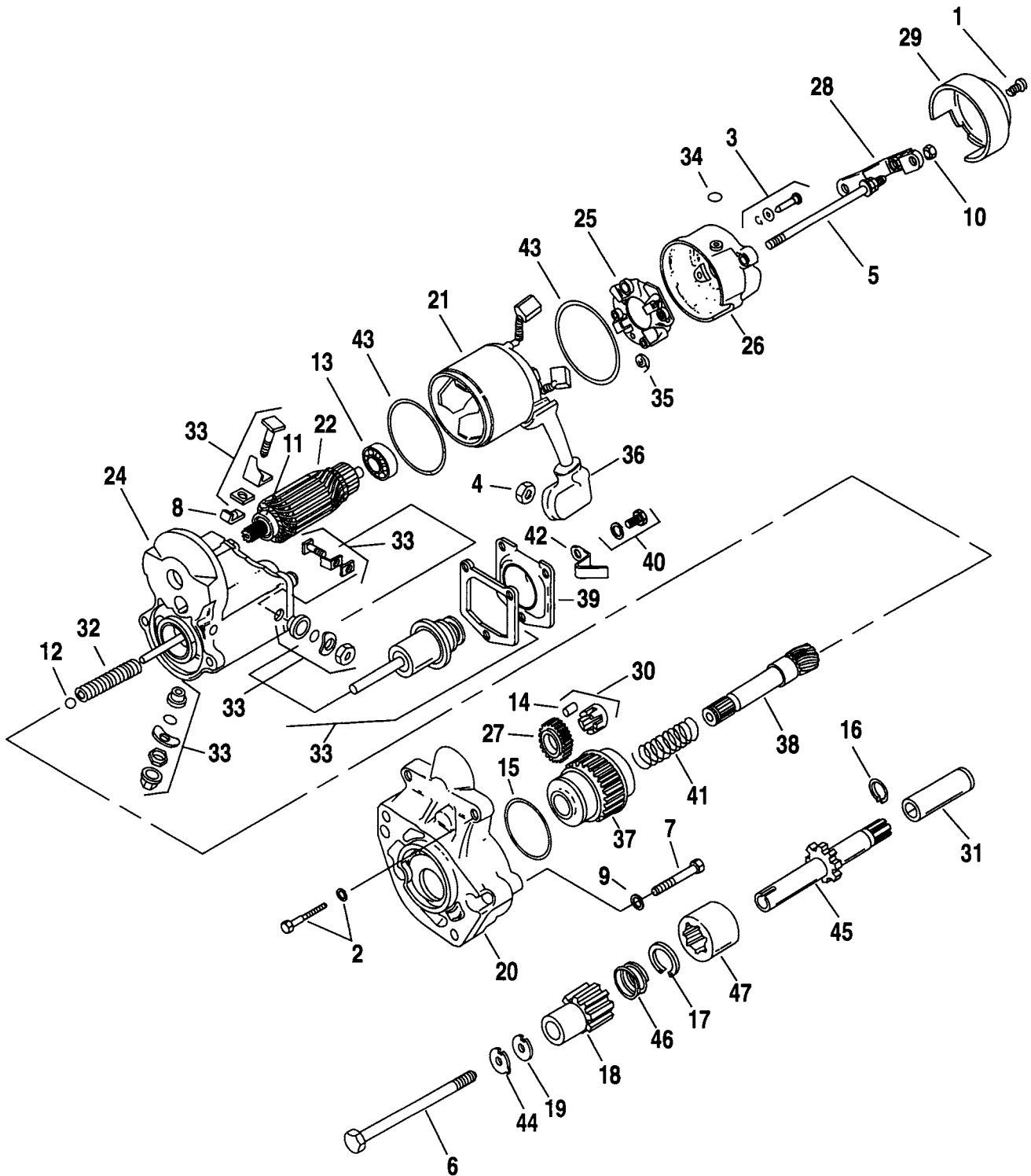

INDEX NO.	PART NO.	DESCRIPTION	FLT MODELS	FXR MODELS	SOFTAIL MODELS	DYNA MODELS
25	31518-90	BRUSH HOLDER ASSEMBLY	93*-ALL	93*-ALL	93*-ALL	93*-ALL
26	31519-90	FRAME, starter end	93*-ALL	93*-ALL	93*-ALL	93*-ALL
27	31525-90	IDLER GEAR	93*-ALL	93*-ALL	93*-ALL	93*-ALL
28	31527-90	BRACKET, cover	93*-ALL	93*-ALL	93*-ALL	93*-ALL
29	31535-91	COVER (chrome)	93*-ALL	93*-ALL	93*-ALL	93*-ALL
30	31530-90	RETAINER, idler gear	93*-ALL	93*-ALL	93*-ALL	93*-ALL
31	31548-90	COUPLING	93*-ALL	93*-ALL	93*-ALL	93*-ALL
	31553-90	STARTER, complete	93-ALL	93-ALL	93-ALL	93-ALL
	31553-94	STARTER, complete	94*-ALL	94*-ALL	94*-ALL	94*-ALL
32	31600-90	SPRING, return	93*-ALL	93*-ALL	93*-ALL	93*-ALL
33	31604-91	STARTER REPAIR KIT	93*-ALL	93*-ALL	93*-ALL	93*-ALL
34	31660-90	DRAIN VENT	93*-ALL	93*-ALL	93*-ALL	93*-ALL
35	31661-90	SPRING, brush (4)	93*-ALL	93*-ALL	93*-ALL	93*-ALL
36	31662-90A	BOOT, insulating	93*-ALL	93*-ALL	93*-ALL	93*-ALL
37	31663-90	CLUTCH, starter	93*-ALL	93*-ALL	93*-ALL	93*-ALL
38	31664-90	SHAFT, output	93-ALL	93-ALL	93-ALL	93-ALL
	31664-94	SHAFT, output	94*-ALL	94*-ALL	94*-ALL	94*-ALL
39	31688-90	COVER, solenoid	93*-ALL	93*-ALL	93*-ALL	93*-ALL
40	31689-90	BOLT w/ washer (3)	93*-ALL	93*-ALL	93*-ALL	93*-ALL
41	31692-90	SPRING	93*-ALL	93*-ALL	93*-ALL	93*-ALL
42	31693-90	CLIP, cable	93*-ALL	93*-ALL	93*-ALL	93*-ALL
43	31695-90	O-RING (2)	93*-ALL	93*-ALL	93*-ALL	93*-ALL
44	33126-93	LOCKPLATE	93-ALL	93-ALL	93-ALL	93-ALL
	33126-94	LOCKPLATE	94*-ALL	94*-ALL	94*-ALL	94*-ALL
45	33127-93	SHAFT, extension	93-ALL	93-ALL	93-ALL	93-ALL
	33127-94	SHAFT, extension	94*-ALL	94*-ALL	94*-ALL	94*-ALL
46	33449-90	SPRING, pinion gear	93-ALL	93-ALL	93-ALL	93-ALL
	33449-94	SPRING, pinion gear	94*-ALL	94*-ALL	94*-ALL	94*-ALL
47	60647-90	COUPLING	93-ALL	93-ALL	93-ALL	93-ALL
	60647-94	COUPLING	94*-ALL	94*-ALL	94*-ALL	94*-ALL

FLT MODELS

FLHTC
FLTC-U
FLHTC-U
FLHS
FLHR

DJ
DM
DP
FA
FD

FXR MODELS

FXR
FXRS-SP
FXLR
FXRS-CON

EA
EG
EL
EM

SOFTAIL MODELS

FLSTC
FXSTC
FXSTS
FLSTF
FLSTN

BJ
BK
BL
BM
BN

DYNA MODELS

FXDL
FXDWG
FXDS-CON

GD
GE
GG

GEAR SHIFTER

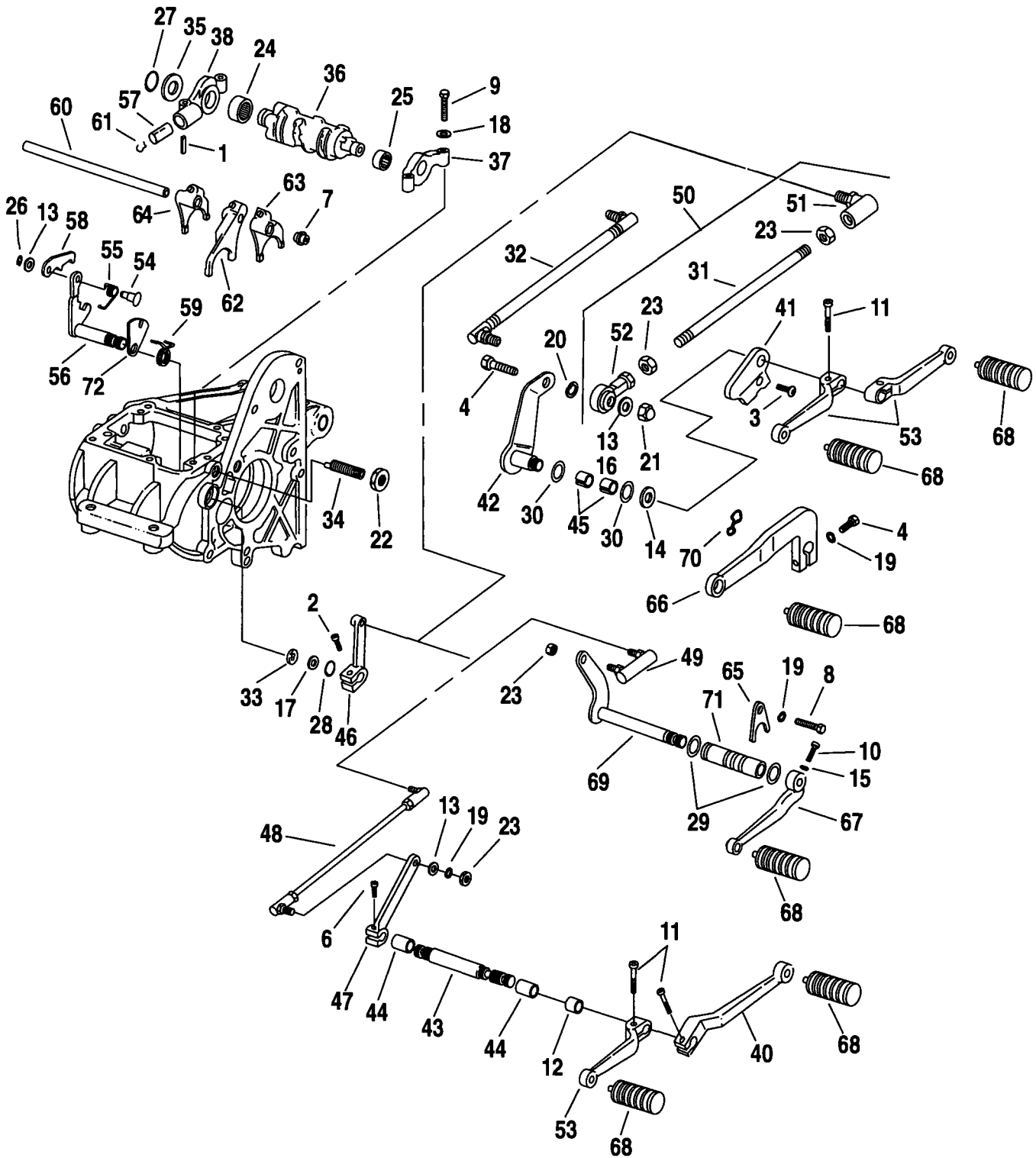

INDEX NO.	PART NO.	DESCRIPTION	FLT MODELS	FXR MODELS	SOFTAIL MODELS	DYNA MODELS
1	601	ROLL PIN	93*-ALL	93*-ALL	93*-ALL	93*-ALL
2	856A	SCREW	93*-ALL	93*-ALL	93*-ALL	93*-ALL
3	1719W	SCREW	--	--	93*-BJ/M/N	--
4	4017	BOLT (2-BJ/K; GD)	--	--	93*-ALL	93*-ALL
6	3444A	SCREW	93*-ALL	--	--	--
7	3784	SET SCREW, shf. fork shaft - left	93*-ALL	93*-ALL	93*-ALL	93*-ALL
8	3987	SCREW	--	--	--	93*-GD/G
9	3993	BOLT (4)	93*-ALL	93*-ALL	93*-ALL	93*-ALL
10	4016	SCREW	--	93*-ALL	--	--
11	4069A	SCREW (2)	93*-ALL	--	93*-BJ/M	--
12	5702	SPACER	93*-ALL	--	--	--
13	6016	WASHER (as required)	93*-ALL	93*-ALL	93*-ALL	93*-GD/G
14	6057	WASHER	--	--	93*-ALL	--
15	6314W	LOCKWASHER	--	93*-ALL	--	--
16	6316HW	WASHER	--	--	93*-ALL	93*-GE
17	6497HW	WASHER	93*-ALL	93*-ALL	93*-ALL	93*-ALL
18	6736	WASHER (4)	93*-ALL	93*-ALL	93*-ALL	93*-ALL
19	7041	LOCKWASHER	93*-ALL	--	93*-BK/L	93*-GD/G
20	7230	LOCKWASHER	--	--	93*-BJ/M/N	--
21	7507	ACORN NUT	--	--	93*-ALL	93*-GD/G
	7736	ACORN NUT	--	--	--	93*-GE
22	7515	JAM NUT	93*-ALL	93*-ALL	93*-ALL	93*-ALL
23	7744	NUT (2 - FXR)	93*-ALL	93*-ALL	--	93*-GD/G
24	9114	NEEDLE BEARING	93*-ALL	93*-ALL	93*-ALL	93*-ALL
25	9115	NEEDLE BEARING	93*-ALL	93*-ALL	93*-ALL	93*-ALL
26	11016	RETAINING RING	93*-ALL	93*-ALL	93*-ALL	93*-ALL
27	11083	RETAINING RING	93*-ALL	93*-ALL	93*-ALL	93*-ALL
28	11150	RETAINING RING	93*-ALL	93*-ALL	93*-ALL	93*-ALL
29	11117	O-RING, sleeve (2)	--	93*-ALL	--	93*-GD/G
30	11191	O-RING (2)	--	--	93*-ALL	--
31	11729	STUD	--	--	93*-ALL	--
32	11739A	SHIFTER ROD	--	--	--	93*-GE
33	12045	SEAL	93*-ALL	93*-ALL	93*-ALL	93*-ALL
34	33119-79B	ADJUSTING SCREW, shifter arm	93*-ALL	93*-ALL	93*-ALL	93*-ALL
35	33205-80	THRUST WASHER, 0.017 thk. (as req'd)	93*-ALL	93*-ALL	93*-ALL	93*-ALL
	33206-80	THRUST WASHER, 0.020 thk. (as req'd)	93*-ALL	93*-ALL	93*-ALL	93*-ALL
	33207-80	THRUST WASHER, 0.022 thk. (as req'd)	93*-ALL	93*-ALL	93*-ALL	93*-ALL
	33208-80	THRUST WASHER, 0.025 thk. (as req'd)	93*-ALL	93*-ALL	93*-ALL	93*-ALL
	33209-80	THRUST WASHER, 0.028 thk. (as req'd)	93*-ALL	93*-ALL	93*-ALL	93*-ALL
	33210-80	THRUST WASHER, 0.031 thk. (as req'd)	93*-ALL	93*-ALL	93*-ALL	93*-ALL
	33211-80	THRUST WASHER, 0.035 thk. (as req'd)	93*-ALL	93*-ALL	93*-ALL	93*-ALL
	33212-80	THRUST WASHER, 0.039 thk. (as req'd)	93*-ALL	93*-ALL	93*-ALL	93*-ALL
36	33320-79D	SHIFTER CAM	93*-ALL	93*-ALL	93*-ALL	93*-ALL
37	33326-79A	SUPPORT, shifter cam - left	93*-ALL	93*-ALL	93*-ALL	93*-ALL
38	33332-79	SUPPORT, shifter cam - right	93*-ALL	93*-ALL	93*-ALL	93*-ALL

FLT MODELS

FLHTC DJ
 FLTC-U DM
 FLHTC-U DP
 FLHS FA
 FLHR FD

FXR MODELS

FXR EA
 FXRS-SP EG
 FXLR EL
 FXRS-CON EM

SOFTAIL MODELS

FLSTC BJ
 FXSTC BK
 FXSTS BL
 FLSTF BM
 FLSTN BN

DYNA MODELS

FXDL GD
 FXDWG GE
 FXDS-CON GG

GEAR SHIFTER

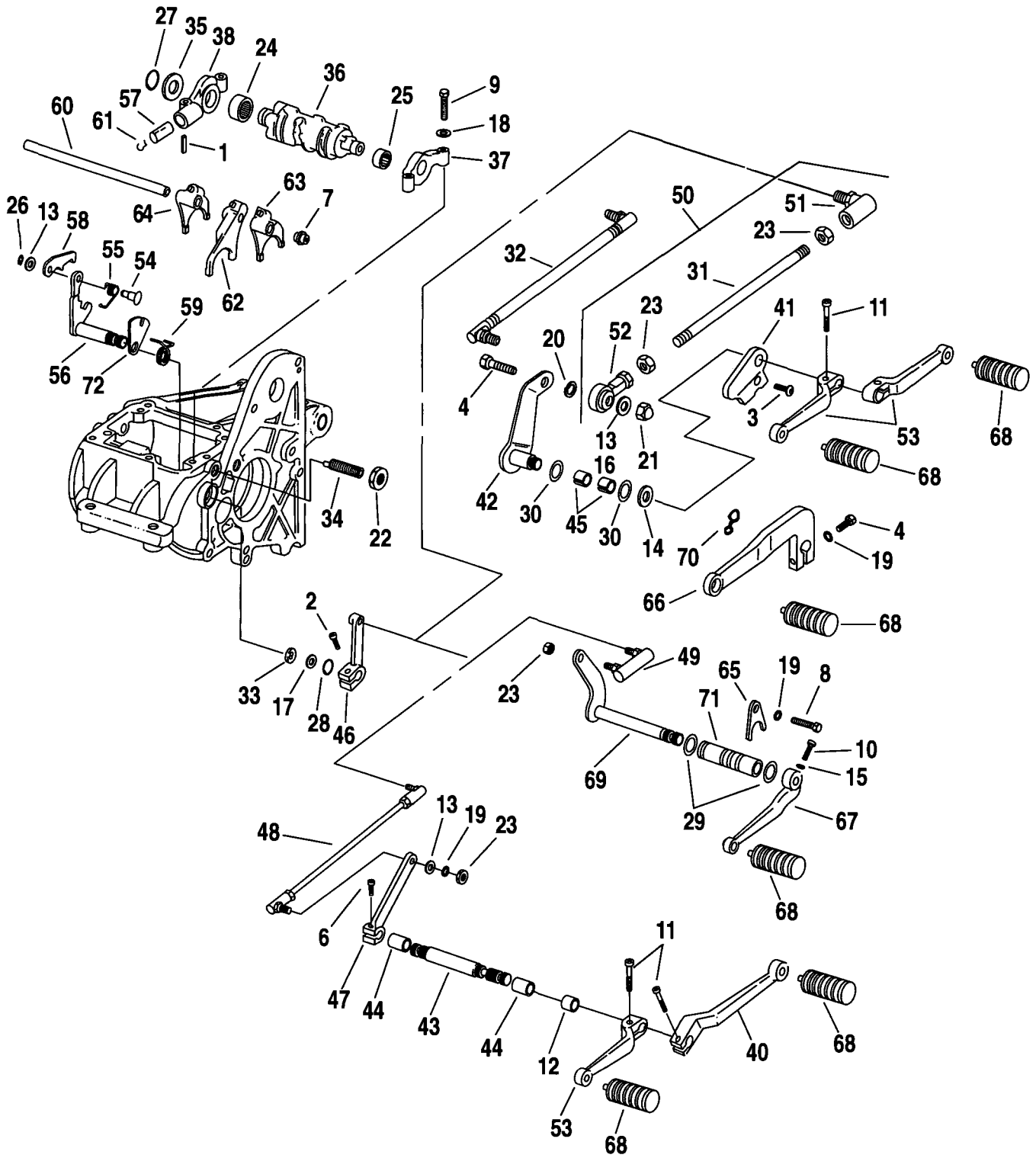

INDEX NO.	PART NO.	DESCRIPTION	FLT MODELS	FXR MODELS	SOFTAIL MODELS	DYNA MODELS
40	33640-83	SHIFT LEVER, heel	93*-ALL	--	--	--
41	33642-89	COVER ASSEMBLY, shifter (chrome)	--	--	93*-BJ/M/N	--
42	33660-90A	SHIFT LEVER (chrome)	--	--	93*-BK/L	93*-GE
	33668-90A	SHIFT LEVER (chrome)	--	--	93*-BJ/M/N	--
43	33709-82	SHAFT	93*-ALL	--	--	--
44	33713-85	BUSHING, shifter bracket (2)	93*-ALL	--	--	--
45	33714-90	BUSHING (2; 3 - GE)	--	--	93*-ALL	93*-GE
46	33715-85	LEVER, shifter rod	93*-ALL	93*-ALL	93*-ALL	93*-ALL
47	33718-82	LEVER	93*-ALL	--	--	--
48	33719-79A	SHIFTER ROD	93*-ALL	--	--	--
49	33728-82A	BALL JOINT	--	93*-ALL	--	93*-GE
50	33728-90	SHIFTER ROD	--	--	--	93*-GD/G
51	33729-82	BALL JOINT	--	--	93*-ALL	--
52	33871-85	END, shifter rod	--	--	93*-ALL	93*-GD/G
53	33895-82	SHIFTER LEVER, (chrome) (2-BJ/M/N)	93*-ALL	--	93*-BJ/M/N	--
54	34082-79	PIN, shifter shaft lever	93*-ALL	93*-ALL	93*-ALL	93*-ALL
55	34083-79	SPRING, shifter shaft lever	93*-ALL	93*-ALL	93*-ALL	93*-ALL
56	34084-86	LEVER, shifter shaft w/#54 & 55	93*-ALL	93*-ALL	93*-ALL	93*-ALL
57	34085-79A	CAM FOLLOWER	93*-ALL	93*-ALL	93*-ALL	93*-ALL
58	34086-79	PAWL, shifter cam	93*-ALL	93*-ALL	93*-ALL	93*-ALL
59	34087-79A	SPRING, shifter shaft	93*-ALL	93*-ALL	93*-ALL	93*-ALL
60	34088-87	SHAFT, shifter fork	93*-ALL	93*-ALL	93*-ALL	93*-ALL
61	34089-79	SPRING	93*-ALL	93*-ALL	93*-ALL	93*-ALL
62	34191-79D	SHIFTER FORK	93*-ALL	93*-ALL	93*-ALL	93*-ALL
63	34193-79D	SHIFTER FORK	93*-ALL	93*-ALL	93*-ALL	93*-ALL
64	34195-79D	SHIFTER FORK	93*-ALL	93*-ALL	93*-ALL	93*-ALL
65	34561-84	SLEEVE LOCATOR PLATE	--	93*-ALL	--	93*-GD/G
66	34564-90A	SHIFT LEVER (chrome)	--	--	93*-BK/L	93*-ALL
67	34599-81	LEVER, shifter	--	93*-ALL	--	--
68	34611-65	PEG, shift lever (2-FLT, BJ/M/N)	93*-ALL	93*-ALL	93*-ALL	93*-ALL
69	34621-84	SHIFT LEVER	--	93*-ALL	--	--
	34621-90	SHIFT LEVER	--	--	--	93*-GD/G
70	34625-90	WAVE WASHER	--	--	--	93*-GE
71	34632-84	SLEEVE, shift lever	-	93*-ALL	--	93*-ALL
72	35068-79	PLATE	93*-ALL	93*-ALL	93*-ALL	93*-ALL
		H-D INTERNATIONAL ONLY				
	14270-92	DECAL, shift pattern (Japan only)	93*-ALL	93*-ALL	93*-ALL	93*-ALL

FLT MODELS

FLHTC DJ
 FLTC-U DM
 FLHTC-U DP
 FLHS FA
 FLHR FD

FXR MODELS

FXR EA
 FXRS-SP EG
 FXLR EL
 FXRS-CON EM

SOFTAIL MODELS

FLSTC BJ
 FXSTC BK
 FXSTS BL
 FLSTF BM
 FLSTN BN

DYNA MODELS

FXDL GD
 FXDWG GE
 FXDS-CON GG

TRANSMISSION HOUSING

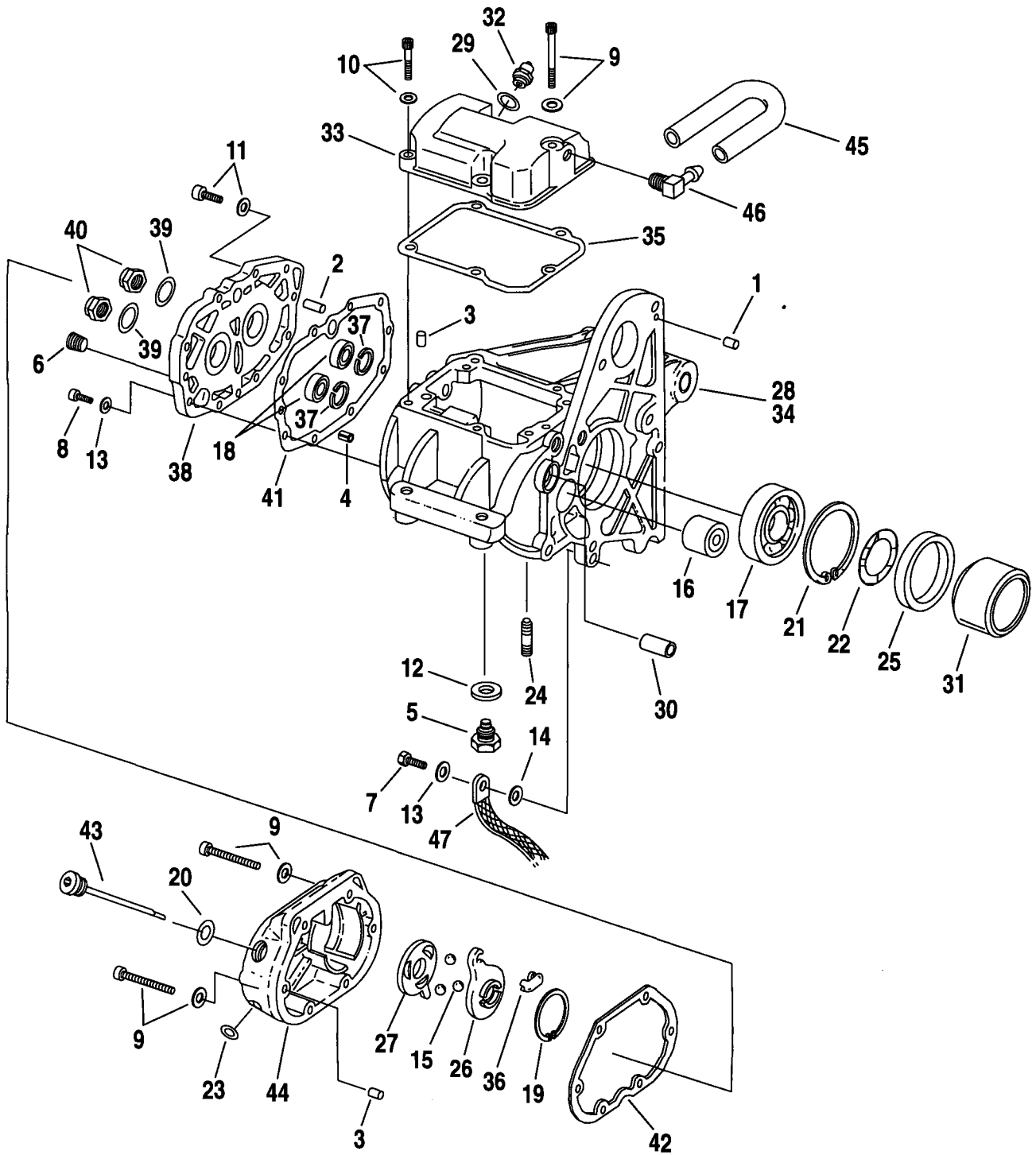

INDEX NO.	PART NO.	DESCRIPTION	FLT MODELS	FXR MODELS	SOFTAIL MODELS	DYNA MODELS
1	337	DOWEL PIN	--	93*-ALL	93*-ALL	--
2	375	DOWEL PIN	--	93*-ALL	93*-ALL	--
3	609	PIN (6; 2 - FLT)	93*-ALL	93*-ALL	93*-ALL	93*-ALL
4	634	PIN	93*-ALL	93*-ALL	93*-ALL	93*-ALL
5	722A	PLUG	--	93*-ALL	--	--
6	739A	PLUG, magnetic	--	--	93*-ALL	--
7	2871W	BOLT	--	93*-ALL	--	--
8	3210A	SCREW (4)	93*-ALL	93*-ALL	93*-ALL	93*-ALL
9	4717A	SCREW (7; 5-Softail)	93*-ALL	93*-ALL	93*-ALL	--
10	4741A	SCREW (4)	93*-ALL	93*-ALL	93*-ALL	--
11	4814A	SCREW (2)	93*-ALL	93*-ALL	93*-ALL	93*-ALL
12	6007	WASHER (nylon)	--	93*-ALL	--	--
13	6016	WASHER (7; 6 - Softail)	93*-ALL	93*-ALL	93*-ALL	93*-ALL
14	7100	LOCKWASHER	--	93*-ALL	--	--
15	8873	BALL (3)	93*-ALL	93*-ALL	93*-ALL	93*-ALL
16	8977	NEEDLE BEARING	--	93*-ALL	93*-ALL	--
17	8996	BALL BEARING, mainshaft - left side	--	93*-ALL	93*-ALL	--
18	8998	BALL BEARING (2)	93*-ALL	93*-ALL	93*-ALL	93*-ALL
19	10998	RETAINING RING	93*-ALL	93*-ALL	93*-ALL	93*-ALL
20	11132	O-RING, filler plug	93*-ALL	93*-ALL	93*-ALL	93*-ALL
21	11161	RETAINING RING, ball bearing	--	93*-ALL	93*-ALL	--
22	11165	QUAD SEAL, ball bearing	93*-ALL	93*-ALL	93*-ALL	93*-ALL
23	11179	O-RING, clutch cable	93*-ALL	93*-ALL	93*-ALL	93*-ALL
24	11733	STUD (5)	--	--	93*-ALL	--
25	12050	OIL SEAL, mainshaft - left side	--	93,E94-ALL	93,E94-ALL	--
	12067A	OIL SEAL, mainshaft - left side	--	L94*-ALL	L94*-ALL	--
26	25452-87A	INNER RAMP	93*-ALL	93*-ALL	93*-ALL	93*-ALL
27	25453-87A	OUTER RAMP	93*-ALL	93*-ALL	93*-ALL	93*-ALL
28	33006-93	TRANSMISSION (C & BW)	--	--	93-ALL	--
	33006-94	TRANSMISSION (C & BW)	--	--	94*-ALL	--
	33013-93	TRANSMISSION (C & BW)	93-DJ/M/P	--	--	--
	33013-94	TRANSMISSION (C & BW)	94*-DJ/M/P	--	--	--
	33017-93	TRANSMISSION	93-FA	--	--	--
	33021-93	TRANSMISSION (C & BW)	--	93-EM	--	--
	33022-93	TRANSMISSION	--	93-EA	--	--
	33022-94	TRANSMISSION	--	94*-EA	--	--
	33024-93	TRANSMISSION (C & BW)	--	93-EL	--	--
	33024-94	TRANSMISSION (C & BW)	--	94*-EL	--	--
	33035-94	TRANSMISSION (C & BW)	94*-FD	--	--	--
	33037-93	TRANSMISSION (C & BW)	--	93-EG	--	--
	33037-94	TRANSMISSION (C & BW)	--	94*-EG	--	--
	33038-93	TRANSMISSION (C & BW)	--	--	--	93-ALL
	33038-94	TRANSMISSION (C & BW)	--	--	--	94*-ALL

FLT MODELS

FLHTC
FLTC-U
FLHTC-U
FLHS
FLHR

DJ
DM
DP
FA
FD

FXR MODELS

FXR
FXRS-SP
FXLR
FXRS-CON

EA
EG
EL
EM

SOFTAIL MODELS

FLSTC
FXSTC
FXSTS
FLSTF
FLSTN

BJ
BK
BL
BM
BN

DYNA MODELS

FXDL
FXDWG
FXDS-CON

GD
GE
GG

TRANSMISSION HOUSING

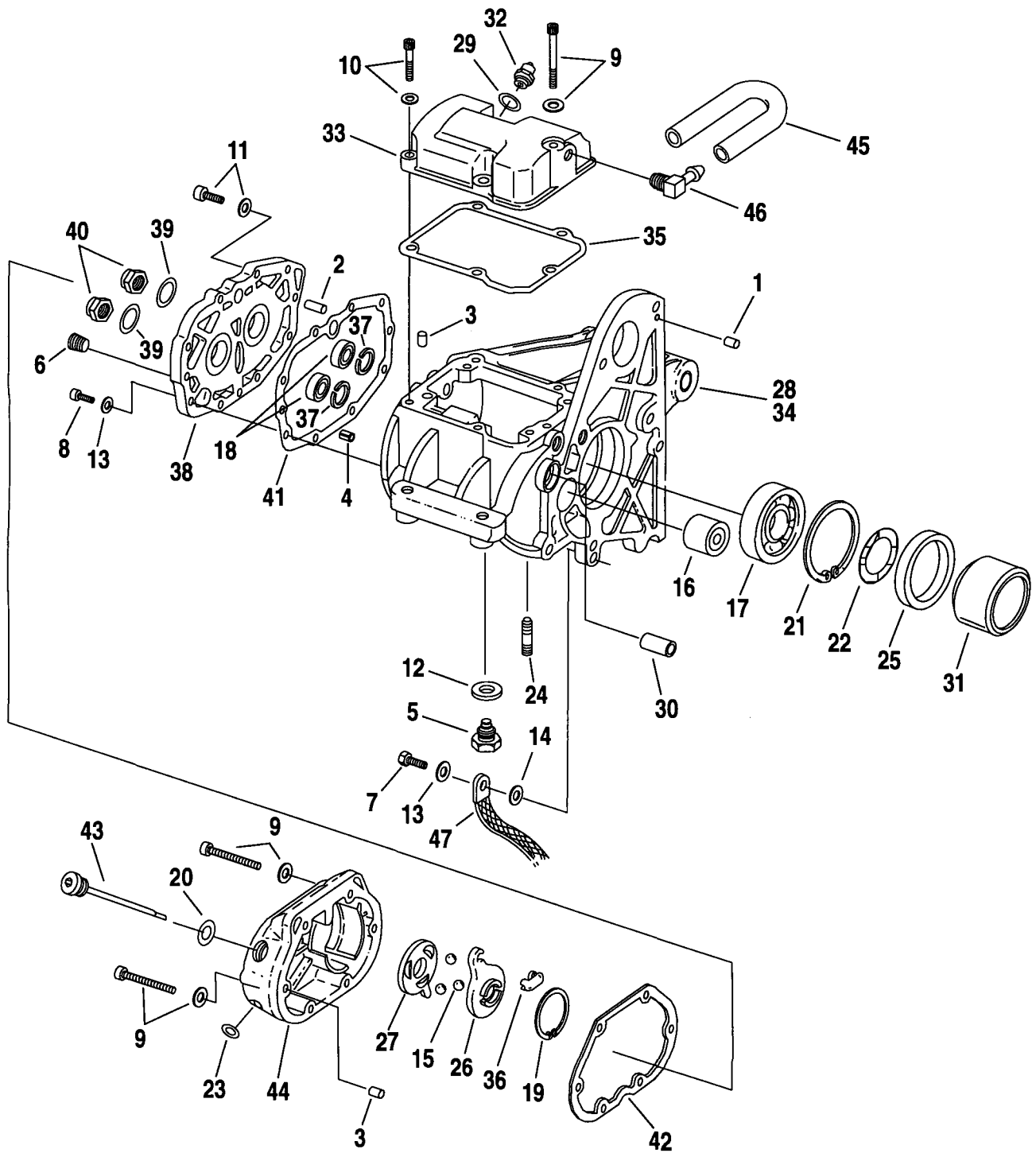

INDEX NO.	PART NO.	DESCRIPTION	FLT MODELS	FXR MODELS	SOFTAIL MODELS	DYNA MODELS
29	33043-80	WASHER, neutral indicator switch	93*-ALL	93*-ALL	93*-ALL	93*-ALL
30	33114-79	SPACER	--	93*-ALL	93*-ALL	--
31	33334-85	SPACER, sprocket	93,E94-ALL	93,E94-ALL	93,E94-ALL	93,E94-ALL
	33344-94	SPACER, sprocket	L94*-ALL	L94*-ALL	L94*-ALL	L94*-ALL
32	33900-59C	SWITCH, neutral indicator	93*-ALL	93*-ALL	93*-ALL	93*-ALL
33	34464-86A	COVER, upper (polished)	93-FA	93*-EA	--	--
	34468-86A	COVER, upper (chrome)	93-DJ/M/P; 94*-ALL	93*-EG/L/M	93*-ALL	--
34	34703-92	HOUSING (black wrinkle)	--	93*-EG/L/M	--	--
	34705-92	HOUSING	--	93*-EA	--	--
	34732-89A	HOUSING (black wrinkle)	--	--	93*-ALL	--
35	34904-86A	GASKET, upper cover	93*-ALL	93*-ALL	93*-ALL	--
36	34920-86	COUPLING	93*-ALL	93*-ALL	93*-ALL	93*-ALL
37	35021-89	RETAINING RING, bearing (2)	94*-ALL	94*-EA/L	94*-ALL	94*-ALL
	11020	RETAINING RING, bearing (2)	93-ALL	93-ALL	93-ALL	93-ALL
38	35250-90B	BEARING HOUSING ASM. w/ #3,18 & 37 (polished)	--	93*-EA	--	--
	35251-93	BEARING HOUSING (polished)	93-FA	--	--	--
	35252-93A	BEARING HOUSING ASM. w/ #3,18 & 37 (black wrinkle)	93-DJ/M/P; 94*-ALL	--	--	--
	35258-87C	BEARING HOUSING ASM. w/ #3,18 & 37 (black wrinkle)	--	--	93*-ALL	--
	35260-90B	BEARING HOUSING w/ # 3,18 & 37 (black wrinkle)	--	93*-EG/L/M	--	93*-ALL
39	35076-79	SPACER (2)	93*-ALL	93*-ALL	93*-ALL	93*-ALL
40	35078-79	NUT, mainshaft & countershaft	93*-ALL	93*-ALL	93*-ALL	93*-ALL
41	35652-79B	GASKET, bearing housing	93*-ALL	93*-ALL	93*-ALL	93*-ALL
42	36801-87B	GASKET, right side cover	93*-ALL	93*-ALL	93*-ALL	93*-ALL
43	37071-87	FILLER PLUG, (polished)	--	93*-EA	--	--
	37075-87	FILLER PLUG (chrome)	--	93*-EG/L/M	93*-ALL	--
44	37081-87A	CLUTCH RELEASE COVER (polished)	93-FA	--	--	--
	37103-87A	CLUTCH RELEASE COVER (polished)	--	93*-EA	--	--
	37105-87A	CLUTCH RELEASE COVER (chrome)	93-DJ/M/P; 94*-ALL	--	93*-ALL	93*-ALL
	37109-87A	CLUTCH RELEASE COVER (chrome)	--	93*-EG/L/M	--	--
45	42533-91	VENT HOSE	93*-ALL	93*-ALL	93*-ALL	93*-ALL
46	62375-57	FITTING, upper cover	93*-ALL	93*-ALL	93*-ALL	--
47	70186-82	GROUND STRAP	--	93*-ALL	--	--
H-D INTERNATIONAL ONLY						
31	33009-94	TRANSMISSION (HDI except Japan)	--	94*-EA	--	--
	33010-94	TRANSMISSION (C & BW) HDI except Japan)	--	94*-EL	--	--
	33019-94	TRANSMISSION (C & BW)(HDI except Japan)	94*-DJ/P	--	--	--
	33036-94	TRANSMISSION (C & BW) (HDI except Japan)	94*-FD	--	--	--
	33040-94	TRANSMISSION (C & BW) (HDI except Japan)	--	--	94*-ALL	--
	33042-94	TRANSMISSION (C & BW) HDI except Japan)	--	--	--	94*-ALL

FLT MODELS
 FLHTC DJ
 FLTC-U DM
 FLHTC-U DP
 FLHS FA
 FLHR FD

FXR MODELS
 FXR EA
 FXRS-SP EG
 FXLR EL
 FXRS-CON EM

SOFTAIL MODELS
 FLSTC BJ
 FXSTC BK
 FXSTF BL
 FLSTF BM
 FLSTN RN

DYNA MODELS
 FXDL GD
 FXDWG GE
 FXDS-CON GG

TRANSMISSION HOUSING & OIL TANK - FLT

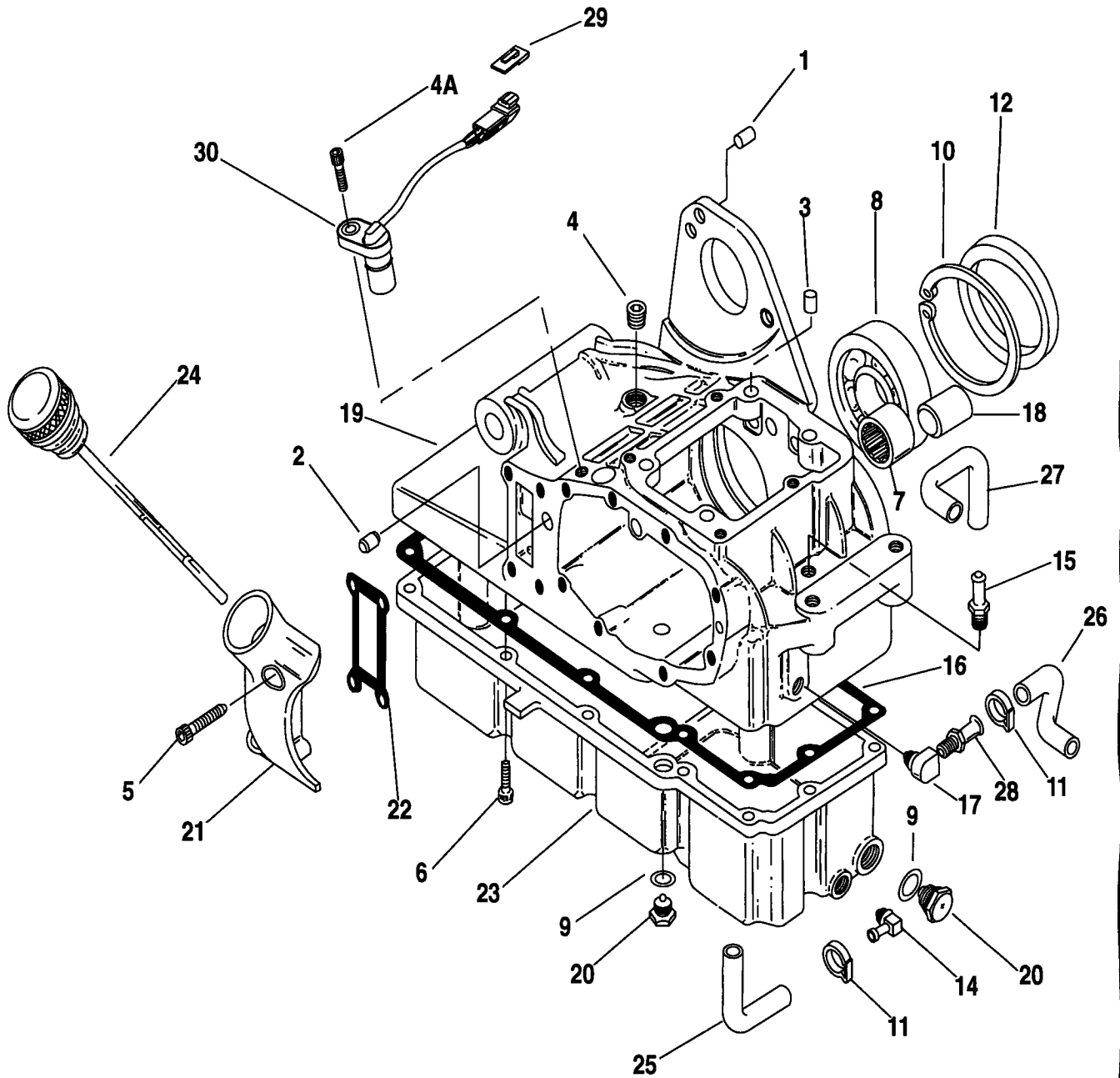

INDEX NO.	PART NO.	DESCRIPTION	FLT MODELS	FXR MODELS	SOFTAIL MODELS	DYNA MODELS
1	337	DOWEL PIN	93*-ALL	--	--	--
2	375	DOWEL PIN	93*-ALL	--	--	--
3	609	PIN, pillow block (4)	93*-ALL	--	--	--
4	721	PLUG	93*-ALL	--	--	--
4A	3594	SCREW	94*-ALL	--	--	--
5	4718A	SCREW (4)	93*-ALL	--	--	--
6	4741A	SCREW (12)	93*-ALL	--	--	--
7	8977	BEARING	93*-ALL	--	--	--
8	8996	BEARING	93*-ALL	--	--	--
9	11105	O-RING (2)	93*-ALL	--	--	--
10	11161	RETAINING RING	93*-ALL	--	--	--
11	10080	CLAMP, hose (2)	93*-ALL	--	--	--
12	12050	OIL SEAL	93,E94-ALL	--	--	--
	12067A	OIL SEAL	L94*-ALL			
14	16304-87	FITTING, 90 degree	93*-ALL	--	--	--
15	25259-93	FITTING, straight	93*-ALL	--	--	--
16	26077-93	GASKET, oil pan	93*-ALL	--	--	--
17	26338-68	FITTING, 90 degree	93*-ALL	--	--	--
	33013-93	TRANSMISSION (C & BW)	93-DJ/M/P	--	--	--
	33013-94	TRANSMISSION (C & BW)	94*-DJ/M/P	--	--	--
	33017-93	TRANSMISSION	93-FA	--	--	--
	33035-94	TRANSMISSION (C & BW)	94*-FD			
18	33114-79	SPACER	93*-ALL	--	--	--
19	34736-93	HOUSING (blk wrkl)	93*-DJ/M/P	--	--	--
	34739-93	HOUSING	93-FA	--	--	--
	34740-94	HOUSING (blk wrkl)	94*-FD			
20	60348-65A	PLUG, magnetic (2)	93*-ALL	--	--	--
21	62419-93	OIL FILLER SPOUT	93-FA	--	--	--
	62429-93	OIL FILLER SPOUT (blk wrkl)	93-DJ/M/P; 94*-ALL	--	--	--
22	62432-93	GASKET, oil spout	93*-ALL	--	--	--
23	62489-93	OIL PAN (blk wrkl)	93-DJ/M/P; 94*-ALL	--	--	--
	62490-93	OIL PAN	93-FA	--	--	--
24	62607-93	FILLER CAP	93-FA	--	--	--
	62640-93	FILLER CAP (blk wrkl)	93-DJ/M/P; 94*-ALL	--	--	--
25	62683-93	HOSE, oil pan to oil pump	93*-ALL	--	--	--
26	62684-93	HOSE, trans. case to filter	93*-ALL	--	--	--
27	63511-93	HOSE, trans. case to crankcase	93*-ALL	--	--	--
28	63533-41	FITTING, straight	93*-ALL	--	--	--
29	72199-94	ATTACHMENT CLIP	94*-FD	--	--	--
30	74420-94	SPEED SENSOR	94*-FD	--	--	--

H-D INTERNATIONAL ONLY

33019-94	TRANSMISSION (C & BW) (HDI except Japan)	94*-DJ/P	--	--	--
33036-94	TRANSMISSION (C & BW) (HDI except Japan)	94*-FD	--	--	--

FLT MODELS

FLHTC
FLTC-U
FLHTC-U
FLHS
FLHR

DJ
DM
DP
FA
FD

FXR MODELS

FXR
FXRS-SP
FXLR
FXRS-CON
EA
EG
EL
EM

SOFTAIL MODELS

FLSTC
FXSTC
FXSTS
FLSTF
FLSTN
BJ
BK
BL
BM
BN

DYNA MODELS

FXDL
FXDWG
FXDS-CON
GD
GE
GG

TRANSMISSION HOUSING & OIL TANK - DYNA

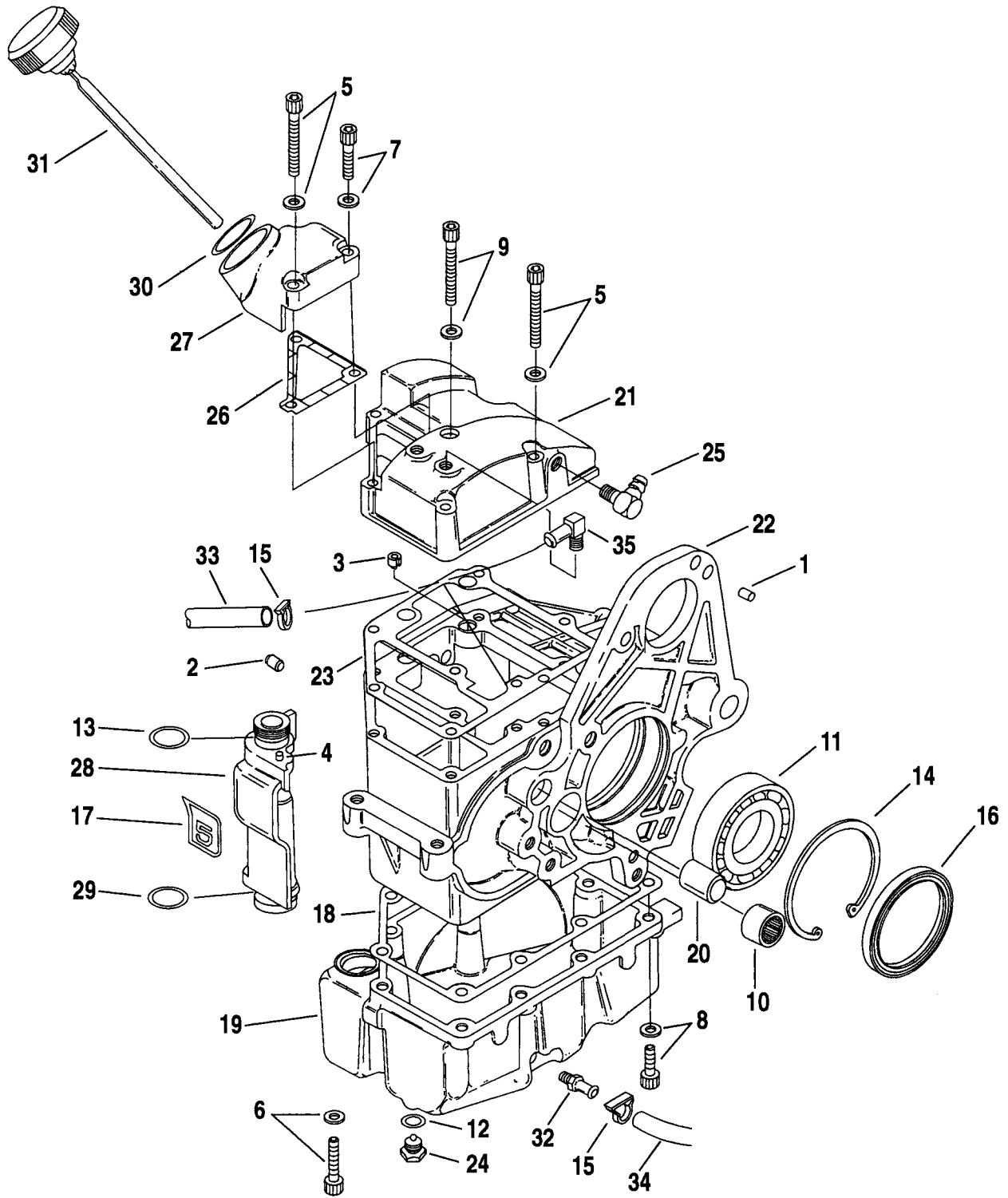

INDEX NO.	PART NO.	DESCRIPTION	FLT MODELS	FXR MODELS	SOFTAIL MODELS	DYNA MODELS
1	337	DOWEL PIN	--	--	--	93*-ALL
2	375	DOWEL PIN	--	--	--	93*-ALL
3	609	PIN, pillow block (2)	--	--	--	93*-ALL
4	631	ROLL PIN	--	--	--	93*-ALL
5	4717A	SCREW (4)	--	--	--	93*-ALL
6	4718A	SCREW (2)	--	--	--	93*-ALL
7	4740A	SCREW	--	--	--	93*-ALL
8	4741A	SCREW (11)	--	--	--	93*-ALL
9	4822A	SCREW	--	--	--	93*-ALL
10	8977	BEARING	--	--	--	93*-ALL
11	8996	BEARING	--	--	--	93*-ALL
12	11105	O-RING (2)	--	--	--	93*-ALL
13	11132	O-RING	--	--	--	93*-ALL
14	11161	RETAINING RING	--	--	--	93*-ALL
15	10080	CLAMP, hose (5)	--	--	--	93*-ALL
16	12050	OIL SEAL	--	--	--	93,E94-ALL
	12067A	OIL SEAL	--	--	--	L94*-ALL
17	14263-91	DECAL, dipstick cover (black)	--	--	--	93*-ALL
18	26072-90A	GASKET, oil pan	--	--	--	93*-ALL
19	26074-90	OIL PAN, (black wrinkle)	--	--	--	93*-ALL
	33038-93	TRANSMISSION	--	--	--	93-ALL
	33038-94	TRANSMISSION	--	--	--	94*-ALL
20	33114-79	SPACER	--	--	--	93*-ALL
21	34469-90	COVER, upper	--	--	--	93*-ALL
22	34747-90A	HOUSING, (black wrinkle)	--	--	--	93*-ALL
23	34917-90A	GASKET, transmission cover	--	--	--	93*-ALL
24	60348-81	MAGNETIC PLUG (2)	--	--	--	93*-ALL
25	62375-57	FITTING, elbow	--	--	--	93*-ALL
26	62423-90A	GASKET, oil spout	--	--	--	93*-ALL
27	62421-90	SPOUT, oil fill (chrome)	--	--	--	93*-ALL
28	62649-90	DIPSTICK COVER	--	--	--	93*-ALL
29	62672-90	O-RING	--	--	--	93*-ALL
30	62673-90	O-RING	--	--	--	93*-ALL
31	62681-92	FILLER CAP	--	--	--	93*-ALL
32	63533-41	FITTING, oil hose	--	--	--	93*-ALL
33	63534-90	HOSE, crankcase to tank vent	--	--	--	93*-ALL
34	63535-90	HOSE, oil pan to pump (feed)	--	--	--	93*-ALL
35	63554-90	FITTING, elbow (2)	--	--	--	93*-ALL
		H-D INTERNATIONAL ONLY				
	33042-94	TRANSMISSION (C & BW)(HDI except Japan)	--	--	--	94*-ALL

FLT MODELS

FLHTC DJ
 FLTC-U DM
 FLHTC-U DP
 FLHS FA
 FLHR FD

FXR MODELS

FXR EA
 FXRS-SP EG
 FXLR EL
 FXRS-CON EM

SOFTAIL MODELS

FLSTC BJ
 FXSTC BK
 FXSTS BL
 FLSTF BM
 FLSTN BN

DYNA MODELS

FXDL GD
 FXDWG GE
 FXDS-CON GG

TRANSMISSION GEARS

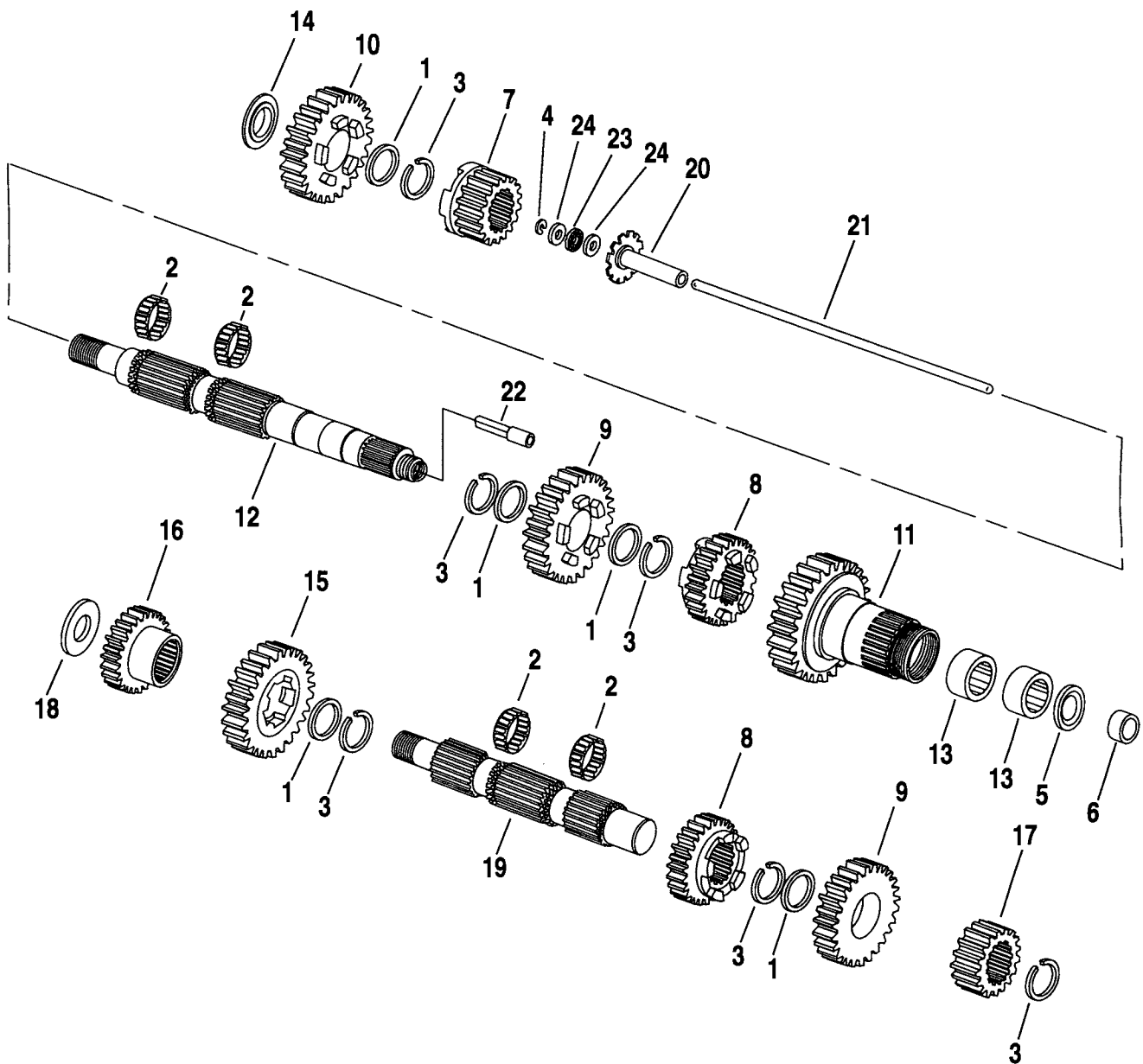

INDEX NO.	PART NO.	DESCRIPTION	FLT MODELS	FXR MODELS	SOFTAIL MODELS	DYNA MODELS
1	6003	THRUST WASHER (5)	93*-ALL	93*-ALL	93*-ALL	93*-ALL
2	8876A	BEARING (4)	93*-ALL	93*-ALL	93*-ALL	93*-ALL
3	11067	RETAINING RING (6)	93*-ALL	93*-ALL	93*-ALL	93*-ALL
4	11096	RETAINING RING	93*-ALL	93*-ALL	93*-ALL	93*-ALL
5	12035	OIL SEAL, mainshaft fifth gear	93*-ALL	93*-ALL	93*-ALL	93*-ALL
6	34091-85	BEARING, inner race	93*-ALL	93*-ALL	93*-ALL	93*-ALL
7	35025-79B	FIRST GEAR, mainshaft	93*-ALL	93*-ALL	93*-ALL	93*-ALL
8	35026-79C	GEAR, mainshaft 2nd & countershaft 3rd (2)	93*-ALL	93*-ALL	93*-ALL	93*-ALL
9	35027-79B	GEAR, mainshaft 3rd & countershaft 2nd (2)	93*-ALL	93*-ALL	93*-ALL	93*-ALL
10	35028-79B	FOURTH GEAR, mainshaft	93*-ALL	93*-ALL	93*-ALL	93*-ALL
11	35029-91A	FIFTH GEAR, mainshaft	93*-ALL	93*-ALL	93*-ALL	93*-ALL
12	35042-91	MAINSHAFT	93*-ALL	93*-ALL	93*-ALL	93*-ALL
13	35051-89	NEEDLE BEARING (2)	93*-ALL	93*-ALL	93*-ALL	93*-ALL
14	35064-79	SPACER, mainshaft	93*-ALL	93*-ALL	93*-ALL	93*-ALL
15	35622-79C	FIRST GEAR, countershaft	93*-ALL	93*-ALL	93*-ALL	93*-ALL
16	35625-79B	FOURTH GEAR, countershaft	93*-ALL	93*-ALL	93*-ALL	93*-ALL
17	35626-79B	FIFTH GEAR, countershaft	93*-ALL	93*-ALL	93*-ALL	93*-ALL
18	35629-79	SPACER	93*-ALL	93*-ALL	93*-ALL	93*-ALL
19	35632-79	COUNTERSHAFT	93*-ALL	93*-ALL	93*-ALL	93*-ALL
20	37069-90	PUSH ROD END	93*-ALL	93*-ALL	93*-ALL	93*-ALL
21	37088-90	PUSH ROD, clutch release (through mainshaft)	93*-ALL	93*-ALL	93*-ALL	93*-ALL
22	37090-84A	END, clutch push rod - left side	93*-ALL	93*-ALL	93*-ALL	93*-ALL
23	37312-75	BEARING	93*-ALL	93*-ALL	93*-ALL	93*-ALL
24	37313-80	THRUST WASHER (2)	93*-ALL	93*-ALL	93*-ALL	93*-ALL

H-D INTERNATIONAL ONLY

8	35026-94	GEAR, mainshaft 2nd & countershaft 3rd (2) (HDI except Japan)	94*-ALL	94*-ALL	94*-ALL	94*-ALL
9	35027-94	GEAR, mainshaft 3rd & countershaft 2nd (2) (HDI except Japan)	94*-ALL	94*-ALL	94*-ALL	94*-ALL
10	35028-94	FOURTH GEAR, mainshaft (HDI except Japan)	94*-ALL	94*-ALL	94*-ALL	94*-ALL
11	35029-94	FIFTH GEAR, mainshaft (HDI except Japan)	94*-ALL	94*-ALL	94*-ALL	94*-ALL
16	35625-94	FOURTH GEAR, countershaft (HDI except Japan)	94*-ALL	94*-ALL	94*-ALL	94*-ALL
17	35626-94	FIFTH GEAR, countershaft (HDI except Japan)	94*-ALL	94*-ALL	94*-ALL	94*-ALL

FLT MODELS

FLHTC DJ
 FLTC-U DM
 FLHTC-U DP
 FLHS FA
 FLHR FD

FXR MODELS

FXR EA
 FXRS-SP EG
 FXLR EL
 FXRS-CON EM

SOFTAIL MODELS

FLSTC BJ
 FXSTC BK
 FXSTS BL
 FLSTF BM
 FLSTN BN

DYNA MODELS

FXDL GD
 FXDWG GE
 FXDS-CON GG

CLUTCH

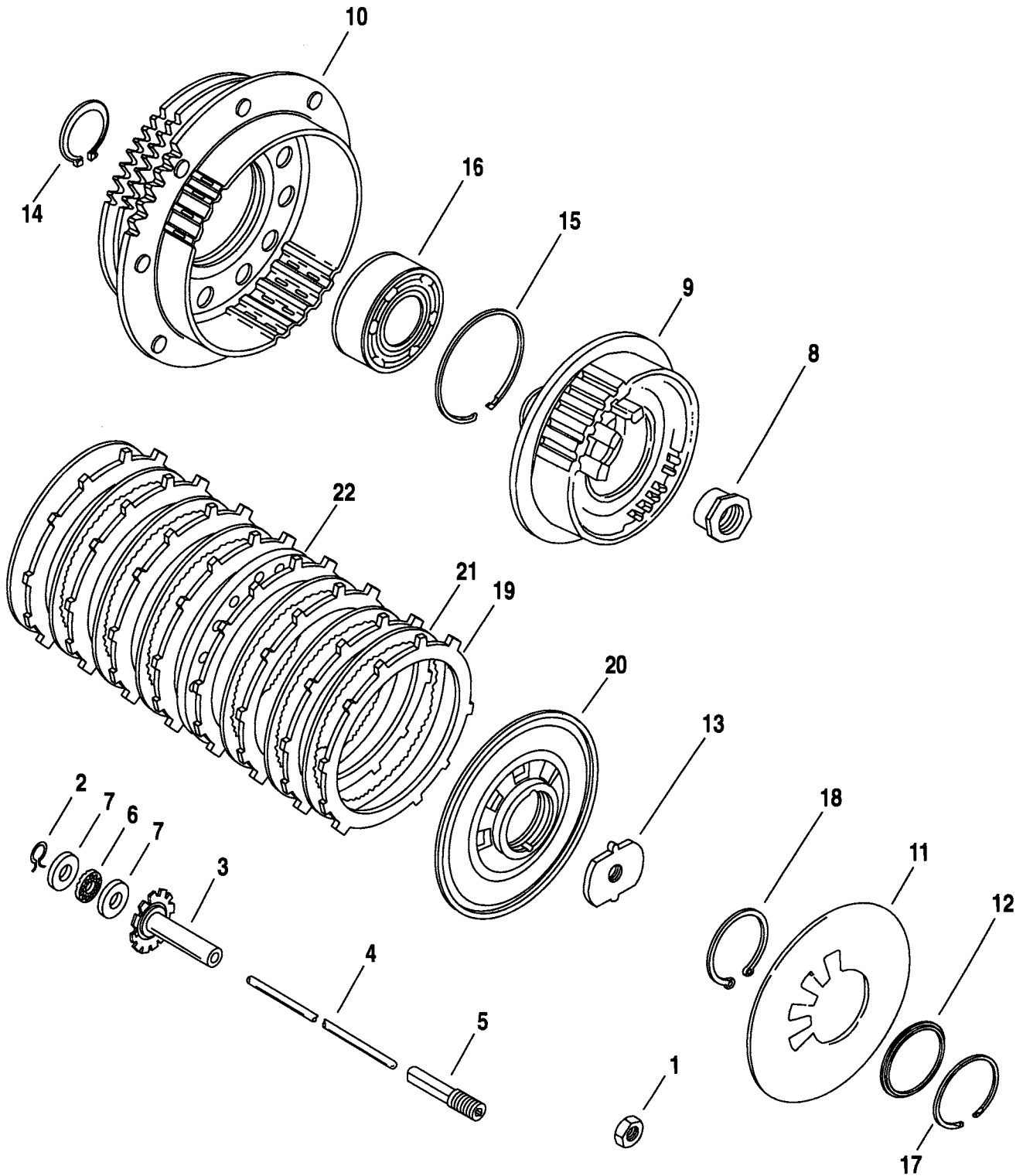

INDEX NO.	PART NO.	DESCRIPTION	FLT MODELS	FXR MODELS	SOFTAIL MODELS	DYNA MODELS
1	7848W	LOCKNUT	93*-ALL	93*-ALL	93*-ALL	93*-ALL
2	11096	RETAINING RING	93*-ALL	93*-ALL	93*-ALL	93*-ALL
3	37069-90	PUSH ROD END	93*-ALL	93*-ALL	93*-ALL	93*-ALL
4	37088-90	PUSH ROD, clutch release	93*-ALL	93*-ALL	93*-ALL	93*-ALL
5	37090-84A	END, push rod - left	93*-ALL	93*-ALL	93*-ALL	93*-ALL
6	37312-75	BEARING, push rod	93*-ALL	93*-ALL	93*-ALL	93*-ALL
7	37313-80	THRUST WASHER (2)	93*-ALL	93*-ALL	93*-ALL	93*-ALL
8	37496-90	NUT, mainshaft	93*-ALL	93*-ALL	93*-ALL	93*-ALL
9	37550-90A	CLUTCH HUB	93*-ALL	93*-ALL	93*-ALL	93*-ALL
10	37707-90	SHELL & SPROCKET w/ RING GEAR	93-ALL	93-ALL	93-ALL	93-ALL
	37707-94	SHELL & SPROCKET w/ RING GEAR	94*-ALL	94*-ALL	94*-ALL	94*-ALL
11	37871-90	SPRING, diaphragm	93*-ALL	93*-ALL	93*-ALL	93*-ALL
12	37872-90	SEAT, clutch spring	93*-ALL	93*-ALL	93*-ALL	93*-ALL
13	37903-90	RELEASE PLATE	93*-ALL	93*-ALL	93*-ALL	93*-ALL
14	37904-90	RETAINING RING, external	93*-ALL	93*-ALL	93*-ALL	93*-ALL
15	37905-90	RETAINING RING, internal	93*-ALL	93*-ALL	93*-ALL	93*-ALL
16	37906-90	BEARING, ball - double row	93*-ALL	93*-ALL	93*-ALL	93*-ALL
17	37908-90	RETAINING RING, internal	93*-ALL	93*-ALL	93*-ALL	93*-ALL
18	37909-90	RETAINING RING, internal	93*-ALL	93*-ALL	93*-ALL	93*-ALL
19	37911-90	FRICTION PLATE (paper) (Set of 8)	93*-ALL	93*-ALL	93*-ALL	93*-ALL
20	37912-91	PRESSURE PLATE	93*-ALL	93*-ALL	93*-ALL	93*-ALL
21	37913-90	STEEL PLATE (smooth) (6)	93*-ALL	93*-ALL	93*-ALL	93*-ALL
	37971-90	CLUTCH PLATE KIT w/#19, 21 & 22	93*-ALL	93*-ALL	93*-ALL	93*-ALL
22	37977-90	SPRING PLATE (smooth)	93*-ALL	93*-ALL	93*-ALL	93*-ALL

FLT MODELS

FLHTC
FLTC-U
FLHTC-U
FLHS
FLHR

DJ
DM
DP
FA
FD

FXR MODELS

FXR
FXRS-SP
FXLR
FXRS-CON

EA
EG
EL
EM

SOFTAIL MODELS

FLSTC
FXSTC
FXSTS
FLSTF
FLSTN

BJ
BK
BL
BM
BN

DYNA MODELS

FXDL
FXDWG
FXDS-CON

GD
GE
GG

CLUTCH CONTROL

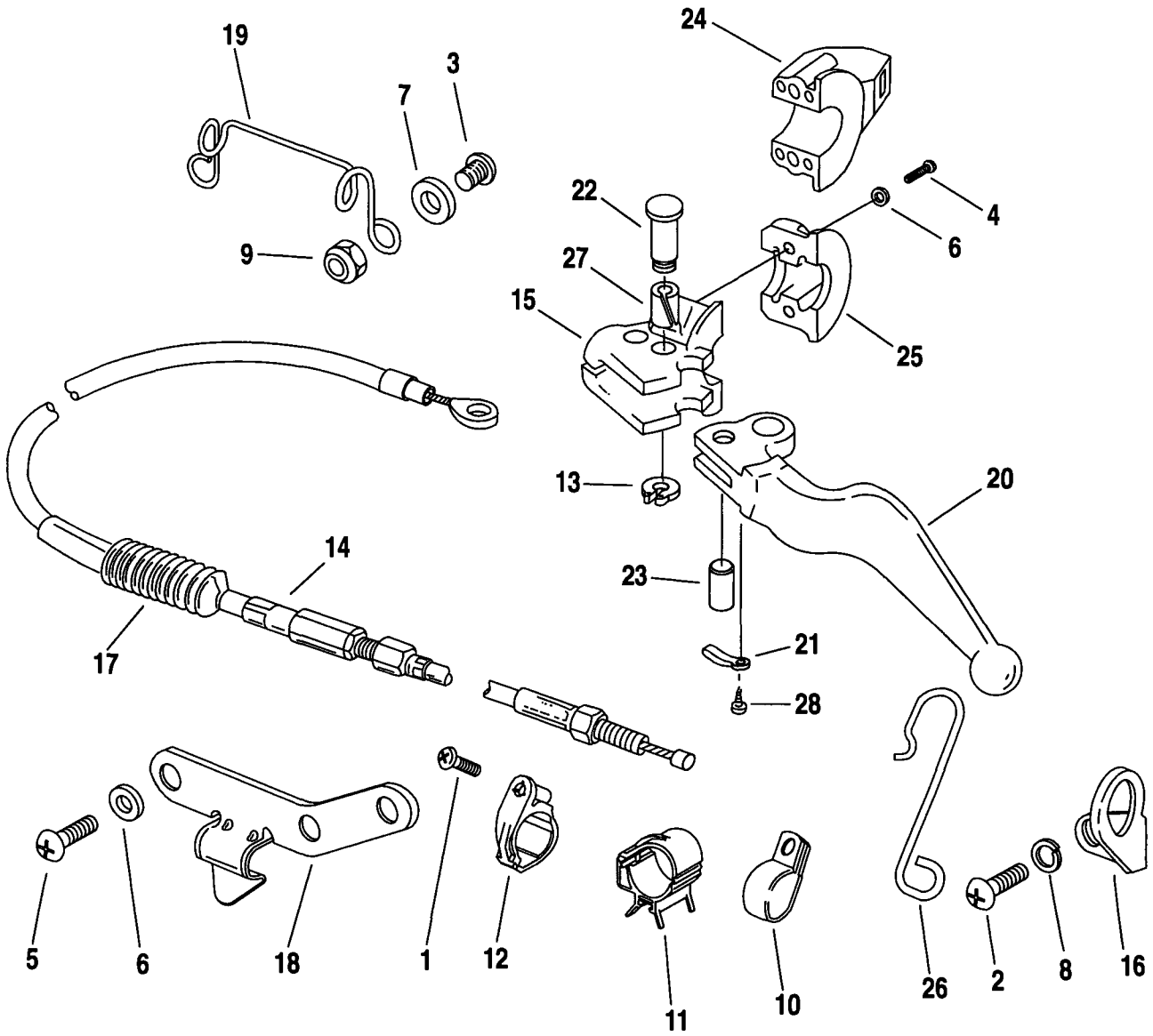

INDEX NO.	PART NO.	DESCRIPTION	FLT MODELS	FXR MODELS	SOFTAIL MODELS	DYNA MODELS
1	2562	SCREW	--	--	93*-ALL	--
2	2782	SCREW	--	93*-ALL	--	--
3	3767B	SCREW (2)	93*-DM	--	--	--
4	4015	SCREW (2)	93*-DJ,FA/D	93*-ALL	93*-ALL	93*-ALL
	4033	SCREW (2)	93*-DM/P	--	--	--
5	4740A	SCREW (2)	93*-ALL	--	--	--
6	6099	WASHER (2)	93*-ALL	93*-ALL	93*-ALL	93*-ALL
7	6703	WASHER (2)	93*-DM	--	--	--
8	7127	LOCKWASHER (2)	--	93*-ALL	--	--
9	7686	LOCKNUT (2)	93*-DM	--	--	--
10	9990W	CLAMP	93*-FA/D	--	--	--
11	10108	CLIP (3)	--	--	--	94*-ALL
12	10124	CLAMP	--	--	93*-ALL	--
13	11143	RETAINING RING	93*-ALL	93*-ALL	93*-ALL	93*-ALL
14	36753-87A	CABLE, clutch control	--	93*-EL	--	--
	36755-87A	CABLE, clutch control	--	93*-EG	--	--
	38601-89	CABLE, clutch control	93*-ALL	--	--	--
	38602-92	CABLE, clutch control	--	--	--	93*-ALL
	38606-87A	CABLE, clutch control	--	93*-EA/M	--	--
	38607-87A	CABLE, clutch control	--	--	93*-ALL	--
15	38608-82B	BRACKET, hand lever	93*-ALL	93*-ALL	93*-ALL	93*-ALL
16	38624-92	BRACKET	--	93*-ALL	--	--
17	38630-88	BOOT, clutch cable	93*-ALL	93*-ALL	93*-ALL	93*-ALL
18	38713-93A	CLAMP, clutch cable	93*-ALL	--	--	--
19	38715-85A	CLIP	93*-DM	--	--	--
20	45017-93	HAND LEVER	93*-ALL	93*-ALL	93*-ALL	93*-ALL
21	45021-86	SPRING, anti-rattle	93*-ALL	93*-ALL	93*-ALL	93*-ALL
22	45032-82	PIN, hand lever pivot	93*-ALL	93*-ALL	93*-ALL	93*-ALL
23	45036-88	ANCHOR PIN	93*-ALL	93*-ALL	93*-ALL	93*-ALL
24	45043-89	CLAMP w/switch housing	93*-DM/P	--	--	--
25	45044-82	CLAMP, lever bracket	93*-DJ,FA/D	93*-ALL	93*-ALL	93*-ALL
26	45090-92	GUIDE, clutch cable	--	93*-ALL	--	--
27	45423-92	BUSHING	93*-ALL	93*-ALL	93*-ALL	93*-ALL
28	90770-79	SCREW	93*-ALL	93*-ALL	93*-ALL	93*-ALL

FLT MODELS

FLHTC DJ
 FLTC-U DM
 FLHTC-U DP
 FLHS FA
 FLHR FD

FXR MODELS

FXR EA
 FXRS-SP EG
 FXLR EL
 FXRS-CON EM

SOFTAIL MODELS

FLSTC BJ
 FXSTC BK
 FXSTS BL
 FLSTF BM
 FLSTN BN

DYNA MODELS

FXDL GD
 FXDWG GE
 FXDS-CON GG

BELTS, CHAINS & SPROCKETS

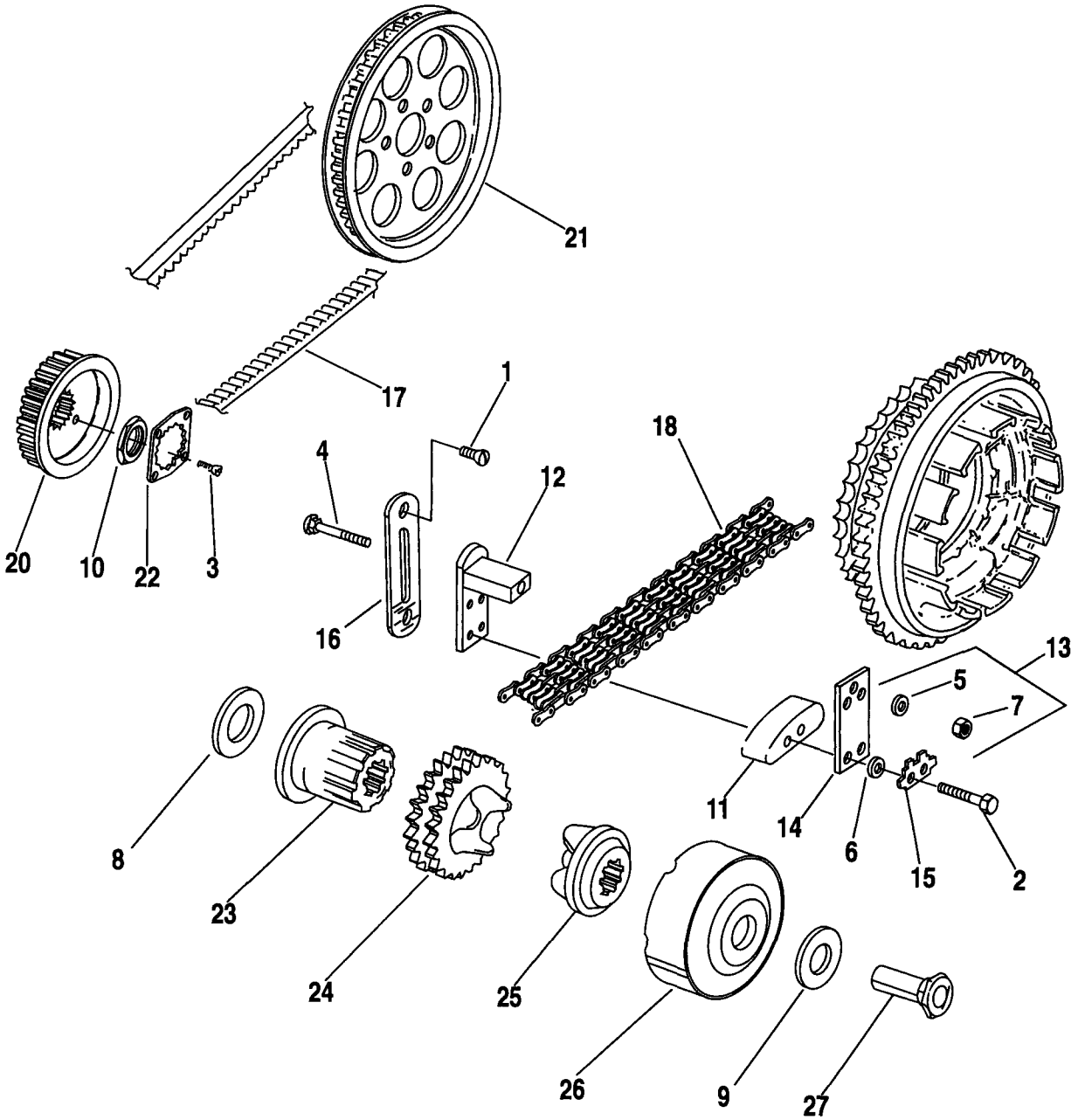

INDEX NO.	PART NO.	DESCRIPTION	FLT MODELS	FXR MODELS	SOFTAIL MODELS	DYNA MODELS
1	1783	SCREW (2)	93*-ALL	93*-ALL	93*-ALL	93*-ALL
2	2614	BOLT (2)	93*-ALL	93*-ALL	93*-ALL	93*-ALL
3	3594	SCREW (2)	93*-ALL	93*-ALL	93*-ALL	93*-ALL
4	5444	BOLT	93*-ALL	93*-ALL	93*-ALL	93*-ALL
5	6400HB	WASHER	93*-ALL	93*-ALL	93*-ALL	93*-ALL
6	6703	WASHER (2)	93*-ALL	93*-ALL	93*-ALL	93*-ALL
7	7778	NUT	93*-ALL	93*-ALL	93*-ALL	93*-ALL
8	24032-70	SPACER, sprkt. sft. - 0.06 thk.	93*-ALL	93*-ALL	93*-ALL	93*-ALL
	24033-70	SPACER, sprkt. sft. - 0.09 thk.	93*-ALL	93*-ALL	93*-ALL	93*-ALL
	24034-70	SPACER, sprkt. sft. - 0.12 thk.	93*-ALL	93*-ALL	93*-ALL	93*-ALL
	24035-70	SPACER, sprkt. sft. - 0.15 thk.	93*-ALL	93*-ALL	93*-ALL	93*-ALL
	24036-70	SPACER, sprkt. sft. - 0.18 thk.	93*-ALL	93*-ALL	93*-ALL	93*-ALL
	24037-70	SPACER, sprkt. sft. - 0.21 thk.	93*-ALL	93*-ALL	93*-ALL	93*-ALL
	35850-84	SPACER, sprkt. sft. - 0.01 thk. (as req'd)	93*-ALL	93*-ALL	93*-ALL	93*-ALL
	35851-84	SPACER, sprkt. sft. - 0.02 thk. (as req'd)	93*-ALL	93*-ALL	93*-ALL	93*-ALL
	35852-84	SPACER, sprkt. sft. - 0.03 thk. (as req'd)	93*-ALL	93*-ALL	93*-ALL	93*-ALL
9	29960-91	SPACER	--	--	93*-ALL	93*-ALL
10	35211-91A	NUT, sprocket	93*-ALL	93*-ALL	93*-ALL	93*-ALL
11	39976-65B	PAD, chain tensioner	93*-ALL	93*-ALL	93*-ALL	93*-ALL
12	39990-65	CHAIN TENSIONER	93*-ALL	93*-ALL	93*-ALL	93*-ALL
13	39992-65C	CHAIN TENSIONER MTG. KIT, w/#4, 5 & 7	93*-ALL	93*-ALL	93*-ALL	93*-ALL
14	39993-65	PLATE, chain tensioner	93*-ALL	93*-ALL	93*-ALL	93*-ALL
15	39996-65	LOCKWASHER, chain tensioner plate	93*-ALL	93*-ALL	93*-ALL	93*-ALL
16	39998-65	ANCHOR PLATE, chain tensioner	93*-ALL	93*-ALL	93*-ALL	93*-ALL
17	40001-85	REAR BELT - 136 T	93*-ALL	93*-ALL	--	--
	40012-90	REAR BELT - 128 T	--	--	93-ALL	--
	40015-90	REAR BELT - 133 T	--	--	--	93*-ALL
	40023-86	REAR BELT - 132 T	--	--	94*-ALL	--
18	40007-36A	PRIMARY CHAIN	--	--	93*-ALL	93*-ALL
	40037-79	PRIMARY CHAIN	93*-ALL	93*-ALL	--	--
20	40210-85D	TRANSMISSION SPROCKET KIT, includes seal, spacer, #3, 10 & 22	93,E94-ALL	93,E94-ALL	93,E94-ALL	93,E94-ALL
21	40250-94	SPROCKET, transmission, 32T.	L94*-ALL	L94*-ALL	L94*-ALL	L94*-ALL
	40217-79A	SPROCKET, rear, 70 T - (black)	93*-ALL	93*-EA	94*-BJ/L/N	93*-ALL
	40221-85A	SPROCKET, rear, 70 T - (silver)	--	93*-EG/L/M	94*-BK/M	--
	40236-88A	SPROCKET, rear, 61 T - (silver)	--	--	93-BK/M	--
	40237-88A	SPROCKET, rear, 61 T - (black)	--	--	93-BJ/L/N	--
22	40251-92	LOCKPLATE	93*-ALL	93*-ALL	93*-ALL	93*-ALL

FLT MODELS

FLHTC DJ
 FLTC-U DM
 FLHTC-U DP
 FLHS FA
 FLHR FD

FXR MODELS

FXR EA
 FXRS-SP EG
 FXLR EL
 FXRS-CON EM

SOFTAIL MODELS

FLSTC BJ
 FXSTC BK
 FXSTS BL
 FLSTF BM
 FLSTN BN

DYNA MODELS

FXDL GD
 FXDWG GE
 FXDS-CON GG

BELTS, CHAINS & SPROCKETS

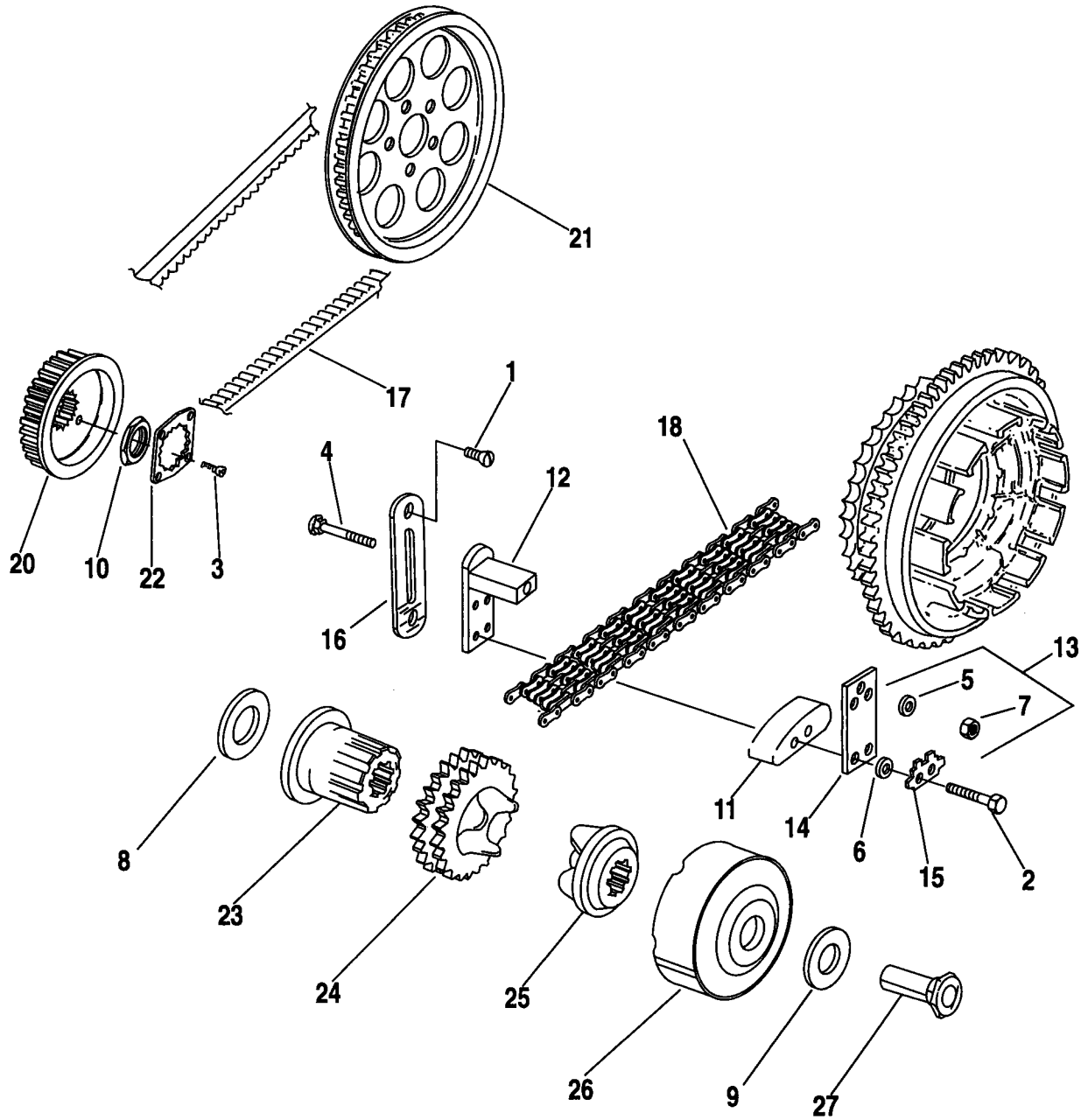

INDEX NO.	PART NO.	DESCRIPTION	FLT MODELS	FXR MODELS	SOFTAIL MODELS	DYNA MODELS
23	40266-85	SHAFT EXTENSION	93*-ALL	93*-ALL	93*-ALL	93*-ALL
24	40269-85A	COMPENSATING SPROCKET	93-ALL	93-ALL	93-ALL	93-ALL
	40308-94	COMPENSATING SPROCKET, 25 T	94*-ALL	94*-ALL	94*-ALL	94*-ALL
25	40299-83A	SLIDING CAM	93*-ALL	93*-ALL	93*-ALL	93*-ALL
26	40384-91	COVER ASSEMBLY, w/springs	93*-ALL	93*-ALL	93*-ALL	93*-ALL
27	40392-91	NUT	93*-ALL	93*-ALL	93*-ALL	93*-ALL
H-D INTERNATIONAL ONLY						
17	40012-90	REAR BELT - 128 T (HDI only & E1994 Australia Softail Models)	--	--	E94-ALL	93-ALL
	40015-90	REAR BELT - 133 T (Swiss only)	94*-ALL	--	--	--
	40017-94	REAR BELT - 130 T (Swiss & L1994 Australia Softail Models)	--	--	94*-ALL	94*-ALL
	40023-86	REAR BELT - 132 T (HDI only)	93-ALL	93-ALL	--	--
21	40236-88A	SPROCKET, rear, 61 T - (silver) (HDI & E1994 Australia Softail Models)	--	93-EG/L/M	E94-BK/M	--
	40237-88A	SPROCKET, rear, 61 T - (black)(HDI & E1994 Australia Softail Models)	93-ALL	93-EA	E94-BJ/L/N	93-ALL
	40311-94	SPROCKET, rear, 65 T - (silver) (Swiss & L1994 Australia Softail Models)	--	--	94*-BK/M	--
	40312-94	SPROCKET, rear, 65 T - (black) (Swiss & L1994 Australia Softail Models)	94*-ALL	94*-ALL	94*-BJ/L/N	94*-ALL

FLT MODELS

FLHTC DJ
 FLTC-U DM
 FLHTC-U DP
 FLHS FA
 FLHR FD

FXR MODELS

FXR EA
 FXRS-SP EG
 FXLR EL
 FXRS-CON EM

SOFTAIL MODELS

FLSTC BJ
 FXSTC BK
 FXSTS BL
 FLSTF BM
 FLSTN BN

DYNA MODELS

FXDL GD
 FXDWG GE
 FXDS-CON GG

REAR BELT GUARD

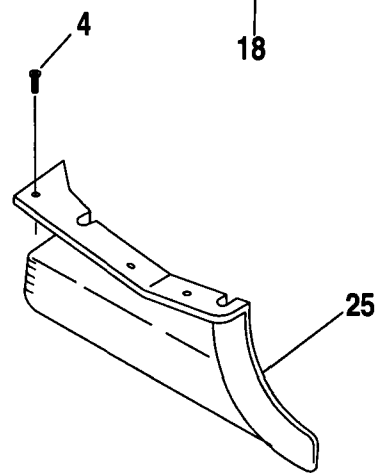
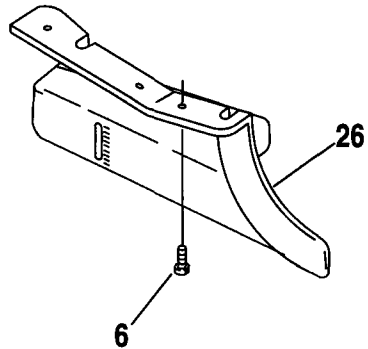
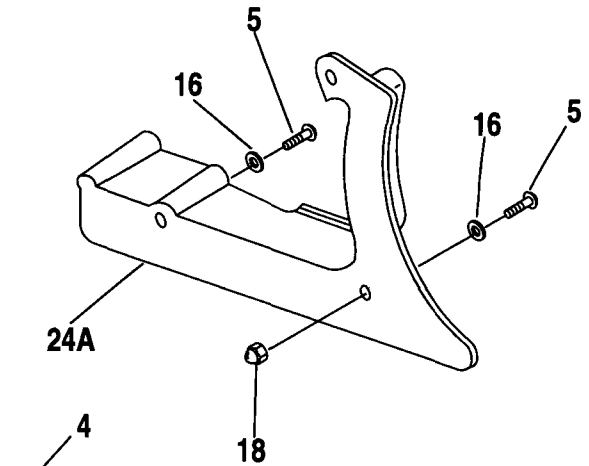
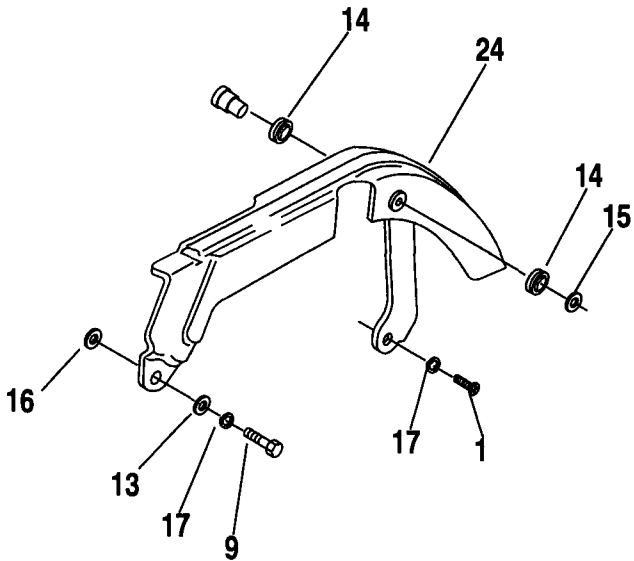
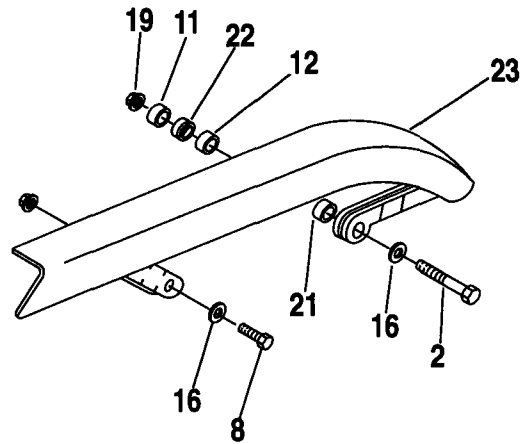
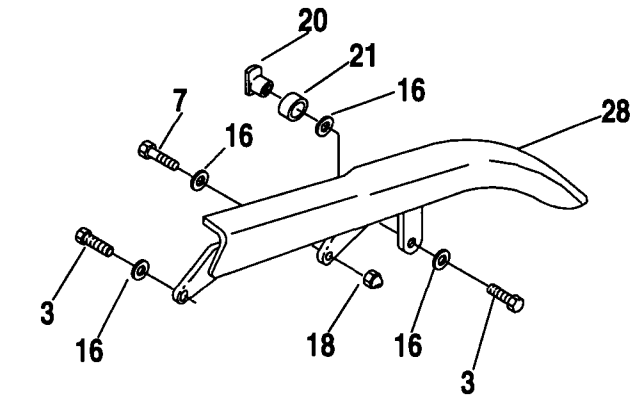

REAR BELT GUARD

FB18

INDEX NO.	PART NO.	DESCRIPTION	FLT MODELS	FXR MODELS	SOFTAIL MODELS	DYNA MODELS
1	2698A	SCREW	--	93*-ALL	--	--
2	2871W	BOLT	--	--	--	93*-ALL
3	2882W	BOLT (2)	--	--	93*-ALL	--
4	3537	SCREW (3)	93*-ALL	93*-ALL	--	--
5	3540	SCREW (2)	--	--	93*-ALL	--
6	3579	SCREW (3)	--	--	--	93*-ALL
7	3987	BOLT	--	--	93*-ALL	--
8	3991	BOLT	--	--	--	93*-ALL
9	4014W	BOLT	--	93*-ALL	--	--
11	5883	SPACER	--	--	--	93*-ALL
12	5926B	SPACER	--	--	--	93*-ALL
13	6107B	WASHER	--	93*-ALL	--	--
14	6398	WASHER (rubber)	--	93*-ALL	--	--
15	6701	WASHER	--	93*-ALL	--	--
16	6702	WASHER (6 - Softail; 2 - DYNA)	--	93*-ALL	93*-ALL	93*-ALL
17	7041	LOCKWASHER	--	93*-ALL	--	--
18	7507	ACORN NUT (2)	--	--	93*-ALL	--
19	7531	LOCKNUT (2)	--	--	--	93*-ALL
20	7669	TEE NUT (2)	--	--	93*-ALL	--
21	11411	GROMMET	--	--	93*-ALL	93*-ALL
22	11458	GROMMET	--	--	--	93*-ALL
23	60293-90	BELT GUARD (chrome)	--	--	--	93*-ALL
24	60297-87A	BELT GUARD	--	93*-ALL	--	--
24A	60362-86A	DEBRIS DEFLECTOR	--	--	94*-ALL	--
	60415-89B	DEBRIS DEFLECTOR	--	--	93-ALL	--
25	60397-85B	DEBRIS DEFLECTOR	93*-ALL	93*-ALL	--	--
26	60399-90A	DEBRIS DEFLECTOR	--	--	--	93*-ALL
28	60533-86	BELT GUARD (chrome)	--	--	94*-ALL	--
	60537-89	BELT GUARD (chrome) w/ #3, 16, 20 & 21	--	--	93-ALL	--
H-D INTERNATIONAL ONLY						
	6109	WASHER (HDI only)	93*-ALL	93*-ALL	--	--
	6235	WASHER (HDI only)	--	93*-ALL	--	--
16	6703	WASHER (HDI only)	--	--	93*-ALL	--
23	60298-88	BELT GUARD (HDI only)	--	93*-ALL	--	--
24	60294-90	BELT GUARD (HDI only)	--	--	--	93*-ALL
23	60427-90	BELT GUARD (chrome) (Swiss)	--	--	--	94*-ALL
26	60403-90A	DEBRIS DEFLECTOR (HDI & 1994 Swiss)	--	--	--	93*-ALL
24A	60415-89B	DEBRIS DEFLECTOR (HDI only)	--	--	94*-ALL	--
28	60555-89	BELT GUARD (HDI only)	--	--	94*-ALL	--

FLT MODELS

FLHTC DJ
 FLTC-U DM
 FLHTC-U DP
 FLHS FA
 FLHR FD

FXR MODELS

FXR EA
 FXRS-SP EG
 FXLR EL
 FXRS-CON EM

SOFTAIL MODELS

FLSTC BJ
 FXSTC BK
 FXSTS BL
 FLSTF BM
 FLSTN BN

DYNA MODELS

FXDL GD
 FXDWG GE
 FXDS-CON GG

FRONT BRAKE CONTROL

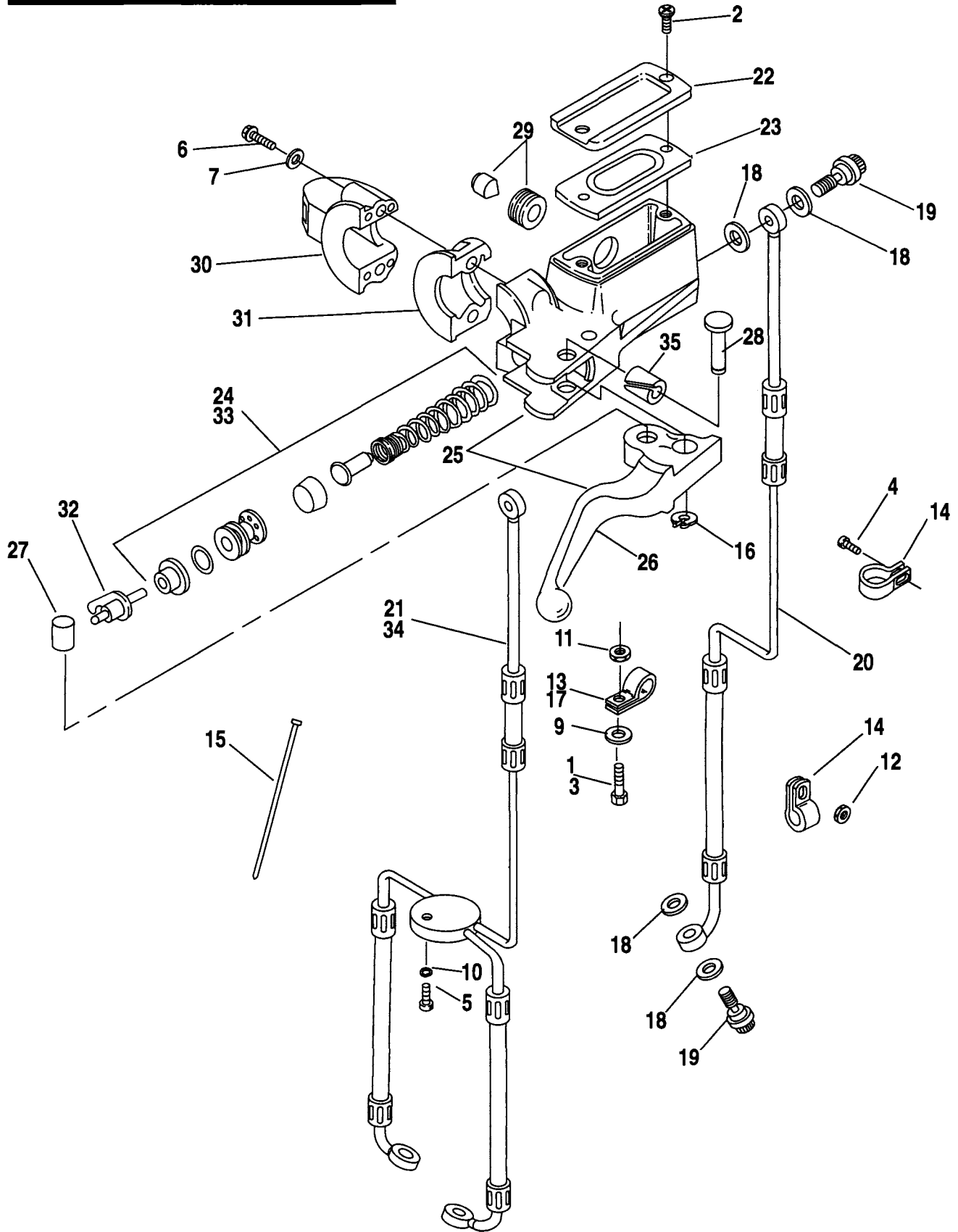

INDEX NO.	PART NO.	DESCRIPTION	FLT MODELS	FXR MODELS	SOFTAIL MODELS	DYNA MODELS
1	923	SCREW	--	--	93*-BJ/M/N	--
2	2579	SCREW (2)	93*-ALL	93*-ALL	93*-ALL	93*-ALL
3	3444A	SCREW	--	93*-EA/L	93*-BJ/L/M	93*-GE
	4104	SCREW	--	93*-ALL	--	94*-GG
4	3538	SCREW	--	--	93*-BL	--
5	3996	SCREW	93*-ALL	--	--	--
	4741A	SCREW	--	93*-EM	--	93*-GD
6	4015	SCREW (2)	93*-DJ,FA	93*-ALL	93*-ALL	93*-ALL
	4033	SCREW (2)	93*-DM/P	--	--	--
7	6099	WASHER (2)	93*-ALL	93*-ALL	93*-ALL	93*-ALL
9	6703	WASHER	--	--	93*-ALL	93*-GE
10	7041	LOCKWASHER	93*-ALL	--	--	--
	7220	LOCKWASHER	--	93*-ALL	93*-ALL	93*-ALL
11	7686	LOCKNUT	--	--	93*-BJ/M/N	--
12	7531	LOCKNUT	--	--	93*-BL	--
13	10031	CLAMP, brake line	--	93*-ALL	93*-BK	93*-ALL
	10053	CLAMP, brake line	--	93*-EA	--	--
14	10076	CLAMP (2)	--	--	93*-BL	--
15	10081	CABLE STRAP, double loop	--	93*-ALL	93*-ALL	--
16	11143	RETAINING RING	93*-ALL	93*-ALL	93*-ALL	93*-ALL
17	41713-86	CLAMP, brake line (3 - BJ)	--	--	93*-BJ/L	93*-GE
18	41731-88A	GASKET, (2; 6 - dual calipers)	93*-ALL	93*-ALL	93*-ALL	93*-ALL
	41733-88	GASKET, master cylinder - single disc (2)	--	93*-EA/L	93*-ALL	93*-GE
19	41739-84A	FITTING, master cylinder - single disc	--	93*-EA/L	93*-ALL	93*-GE
	41747-82A	FITTING, (3 - dual calipers)	93*-ALL	93*-ALL	93*-ALL	93*-ALL
20	42303-89A	BRAKE LINE	--	--	93*-BM/N	--
	42305-86A	BRAKE LINE	--	--	93*-BJ	--
	45110-88B	BRAKE LINE	--	--	93*-BL	--
	45112-84A	BRAKE LINE	--	--	93*-BK	93*-GE
	45121-88A	BRAKE LINE	--	93*-EA	--	--
	45141-87A	BRAKE LINE	--	93*-EL	--	--
21	43349-84B	BRAKE LINE	93-ALL;94* DJ/M/P	--	--	--
	43350-94	BRAKE LINE	94*-FD	--	--	--
22	45004-85	COVER, master cylinder	93*-ALL	93*-ALL	93*-ALL	93*-ALL
23	45005-85	GASKET, master cylinder cover	93*-ALL	93*-ALL	93*-ALL	93*-GD/G
24	45006-87A	REPAIR KIT, master cylinder	93*-ALL	--	--	93*-GD/G
25	45013-93	MASTER CYLINDER, w/ hand lever	93*-ALL	93*-EG/M	--	93*-GD/G
	45019-93	MASTER CYLINDER, w/ hand lever	--	93*-EA/L	93*-ALL	93*-GE
26	45016-93	HAND LEVER	93*-ALL	93*-ALL	93*-ALL	93*-ALL
27	45031-82A	PIN, stoplamp switch & pushrod	93*-ALL	93*-ALL	93*-ALL	93*-ALL
28	45032-82	PIN, hand lever pivot	93*-ALL	93*-ALL	93*-ALL	93*-ALL
29	45042-82	SIGHT GLASS REPAIR KIT	93*-ALL	93*-ALL	93*-ALL	93*-ALL
30	45043-89	CLAMP, w/ switch housing	93*-DM/P	--	--	--
31	45044-82	CLAMP, master cylinder	93*-DJ,FA/D	93*-ALL	93*-ALL	93*-ALL
32	45051-82	PUSHROD, stoplamp switch	93*-ALL	93*-ALL	93*-ALL	93*-ALL
33	45072-87	REPAIR KIT, master cylinder	--	93*-EA/L	93*-ALL	93*-GE
34	45111-89	BRAKE LINE	--	93*-EM	--	93*-GD/G
	45140-87	BRAKE LINE	--	93*-EG	--	--
35	45423-92	BUSHING	93*-ALL	93*-ALL	93*-ALL	93*-ALL

FLT MODELS

FLHTC
FLTC-U
FLHTC-U
FLHS
FLHR

DJ
DM
DP
FA
FD

FXR MODELS

FXR
FXRS-SP
FXLR
FXRS-CON
EA
EG
EL
EM

SOFTAIL MODELS

FLSTC
FXSTC
FXSTS
FLSTF
FLSTN
BJ
BK
BL
BM
BN

DYNA MODELS

FXDL
FXDWG
FXDS-CON
GD
GE
GG

FRONT BRAKE CALIPER

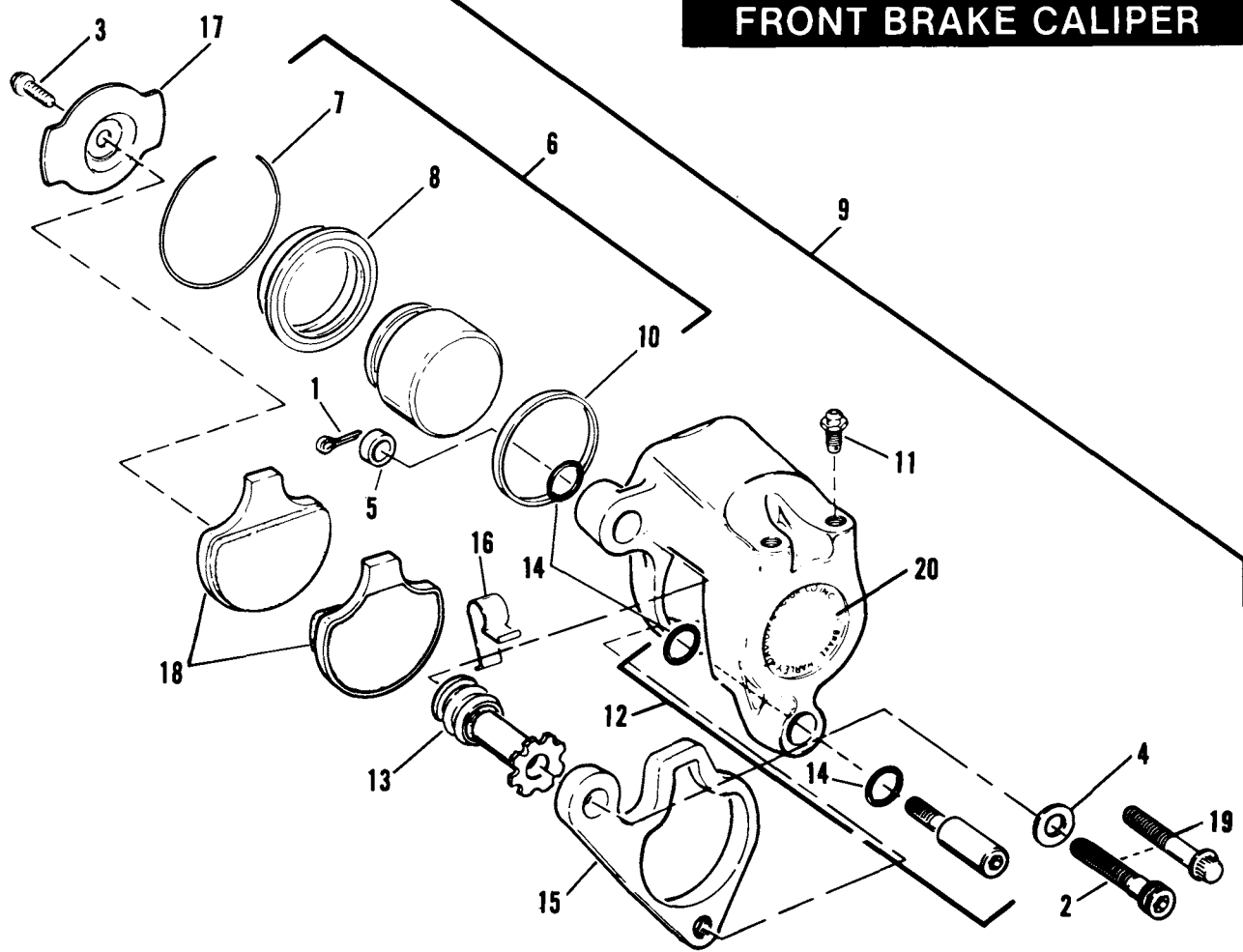

INDEX NO.	PART NO.	DESCRIPTION	FLT MODELS	FXR MODELS	SOFTAIL MODELS	DYNA MODELS
1	534	COTTER PIN	--	--	93*-BL	--
2	855B	SCREW (2 - dual calipers)	93*-ALL	93*-ALL	93*-ALL	93*-ALL
3	3562	SCREW (2 - dual calipers)	93*-ALL	93*-ALL	93*-ALL	93*-ALL
4	6019	WASHER (2 - dual calipers)	93*-ALL	93*-ALL	93*-ALL	93*-ALL
5	6758	WASHER	--	--	93*-BL	--
6	44020-83	PISTON REBUILD KIT, w/ #8, 9 &10 (2 - dual calipers)	93*-ALL	93*-ALL	93*-ALL	93*-ALL
7	44021-83	RETAINING RING, piston (2 - dual calipers)	93*-ALL	93*-ALL	93*-ALL	93*-ALL
8	44022-83	DUST BOOT, piston (2 - dual calipers)	93*-ALL	93*-ALL	93*-ALL	93*-ALL
9	44023-83B	CALIPER ASSEMBLY, right	93*-ALL	93*-EG/M	--	93*-GD/G
	44046-84B	CALIPER ASSEMBLY, left	93*-ALL	93*-ALL	93*-BJ/K/ M/N	93*-ALL
	44077-88C	CALIPER ASSEMBLY, right	--	--	93*-BL	--
10	44047-83	SEAL, piston (2 - dual calipers)	93*-ALL	93*-ALL	93*-ALL	93*-ALL
11	44048-83	BLEEDER FITTING (2 - dual calipers)	93*-ALL	93*-ALL	93*-ALL	93*-ALL
12	44053-83A	GUIDE PIN KIT w/ #13, 14 & mtg. pins	--	--	93*-BL	--
	44053-92	GUIDE PIN KIT w/ #13, 14 & mtg. pins (2 - dual calipers)	93*-ALL	93*-ALL	93*-BJ/K/ M/N	93*-ALL
13	44054-83	PIN BOOT (2 - dual calipers)	93*-ALL	93*-ALL	93*-ALL	93*-ALL
14	44059-83	O-RING (3; 6 - dual calipers)	93*-ALL	93*-ALL	93*-ALL	93*-ALL
15	44072-92	BRACKET, caliper mounting (left)	93*-ALL	93*-ALL	93*-BJ/K/ M/N	93*-ALL
	44073-92	BRACKET, caliper mounting, (right)	93*-ALL	93*-EG/M	--	93*-GD/G
	44074-88A	BRACKET, caliper mounting	--	--	93*-BL	--
16	44061-83	SPRING CLIP (2 - dual calipers)	93*-ALL	93*-ALL	93*-ALL	93*-ALL
17	44062-83	RETAINING PAD (2 - dual calipers)	93*-ALL	93*-ALL	93*-ALL	93*-ALL
18	44063-83C	PAD SET, w/ #3 (2 - dual calipers)	93*-ALL	93*-ALL	93*-ALL	93*-ALL
19	44190-88	SCREW, flange	--	--	93*-BL	--
20	44197-77	LABEL (2 - dual calipers)	93*-ALL	93*-ALL	93*-ALL	93*-ALL

NOTE: FOR FXSTS CALIPER MOUNTING SEE SECTION FB25E.

FLT MODELS

FLHTC DJ
 FLTC-U DM
 FLHTC-U DP
 FLHS FA
 FLHR FD

FXR MODELS

FXR EA
 FXRS-SP EG
 FXLR EL
 FXRS-CON EM

SOFTAIL MODELS

FLSTC BJ
 FXSTC BK
 FXSTS BL
 FLSTF BM
 FLSTN BN

DYNA MODELS

FXDL GD
 FXDWG GE
 FXDS-CON GG

FRONT WHEEL

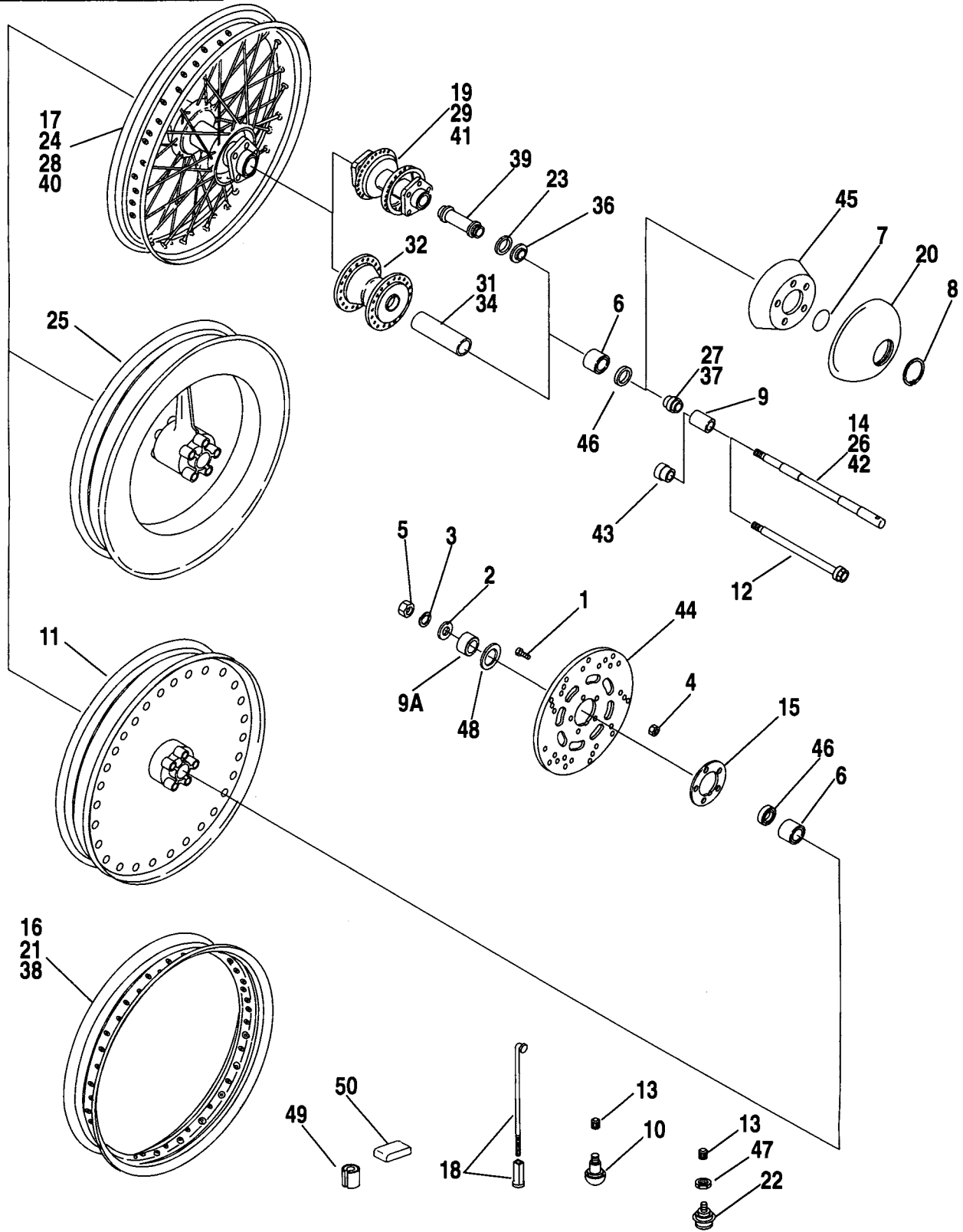

INDEX NO.	PART NO.	DESCRIPTION	FLT MODELS	FXR MODELS	SOFTAIL MODELS	DYNA MODELS
1	3655	SCREW (5; 10 - FLT, EG; BM; GD)	93*-ALL	93*-ALL	93*-ALL	93*-ALL
2	6590HW	WASHER	--	93*-ALL	93*-BJ/K/ M/N	93*-ALL
	6639	WASHER, left	--	--	93*-BL	--
3	7068	LOCKWASHER	93*-ALL	93*-ALL	93*-BJ/K/ M/N	93*-ALL
4	7739	LOCKNUT (10; 5 - SOFTAIL)	93*-ALL	--	93*-ALL	--
5	7845	NUT	93*-ALL	93*-ALL	93*-BJ/K/ M/N	93*-ALL
	7994	LOCKNUT	--	--	93*-BL	--
6	9052	ROLLER BEARING (2)	93*-ALL	93*-ALL	93*-ALL	93*-ALL
7	11173	O-RING	--	--	93*-BJ/N	--
8	11175	SNAP RING	--	--	93*-BJ/N	--
9	40910-84A	SPACER, right bearing	93*-ALL	--	93*-BK	93*-GE
	43657-89	SPACER, right bearing	--	--	93*-BM	--
9A	40915-94	SPACER, left	94*-FD	--	--	--
10	40999-87	VALVE STEM	93*-ALL	--	--	--
11	41043-89	DISC WHEELASSEMBLY, 16"	--	--	E93-BM	--
	41043-89A	DISC WHEELASSEMBLY, 16"	--	--	L93*-BM	--
12	41109-88	AXLE	--	--	93*-BL	--
13	41123-79	VALVE CAP	93*-ALL	93*-ALL	93*-ALL	93*-ALL
14	41584-86	AXLE	--	--	93*-BJ/ M/N	--
15	41814-76A	HUB PLATE	--	93*-EL	--	--
	43359-84	HUB PLATE	--	93*-EA	--	--
16	43001-79	RIM, 19" (chrome)	--	93*-EA	--	--
17	43005-86	WHEELASSEMBLY, 16" laced	--	--	93*-BJ/N	--
18	43020-87	SPOKE & NIPPLE SET, 21" short (20)	--	93*-EL	--	--
	43024-73B	SPOKE & NIPPLE SET, 19" short (20)	--	93*-EA	--	--
	43025-73B	SPOKE & NIPPLE SET, 19" long (20)	--	93*-EA	--	--
	43032-40B	SPOKE & NIPPLE SET, 16" (40)	93*-ALL	--	93*-BJ/N	--
	43035-87	SPOKE & NIPPLE SET, 21" long (20)	--	93*-EL	--	--
	43057-80A	SPOKE & NIPPLE SET, 21" (40)	--	--	93*-BK/L	93*-GE
19	43053-86	HUB, w/ bearings, seals & spacers	--	--	93*-BJ/N	--
20	43067-86	CAP, hub (chrome)	--	--	93*-BJ/N	--
21	43085-81	RIM, 16" (chrome)	93*-ALL	--	93*-BJ/N	--
22	43150-83	VALVE STEM	--	93*-EA/G/M	--	93*-GD/G
	43157-83A	VALVE STEM	93*-ALL	--	93*-BM	--
23	43290-82	SPACER, 0.032 thk.	93*-ALL	93*-ALL	93*-ALL	93*-ALL
	43291-82	SPACER, 0.016 thk.	93*-ALL	93*-ALL	93*-ALL	93*-ALL
	43292-82	SPACER, 0.008 thk.	93*-ALL	93*-ALL	93*-ALL	93*-ALL
	43293-82	SPACER, 0.004 thk.	93*-ALL	93*-ALL	93*-ALL	93*-ALL
	43294-82	SPACER, 0.002 thk.	93*-ALL	93*-ALL	93*-ALL	93*-ALL
24	43312-84	WHEEL ASSEMBLY, 19" laced	--	93*-EA	--	--
25	43338-83	WHEEL ASSEMBLY, 19" - 9 spoke (silver)	--	93*-EG/M	--	--
	43345-87	WHEEL ASSEMBLY, 16" - 10 spoke (black)	93*-ALL	--	--	--
	43626-84	WHEEL ASSEMBLY, 19" - 9 spoke (black)	--	93*-EA	--	93*-GD/G

FLT MODELS

FLHTC
FLTC-U
FLHTC-U
FLHS
FLHR

DJ
DM
DP
FA
FD

FXR MODELS

FXR
FXRS-SP
FXLR
FXRS-CON
EA
EG
EL
EM

SOFTAIL MODELS

FLSTC
FXSTC
FXSTS
FLSTF
FLSTN
BJ
BK
BL
BM
BN

DYNA MODELS

FXDL
FXDWG
FXDS-CON
GD
GE
GG

FRONT WHEEL

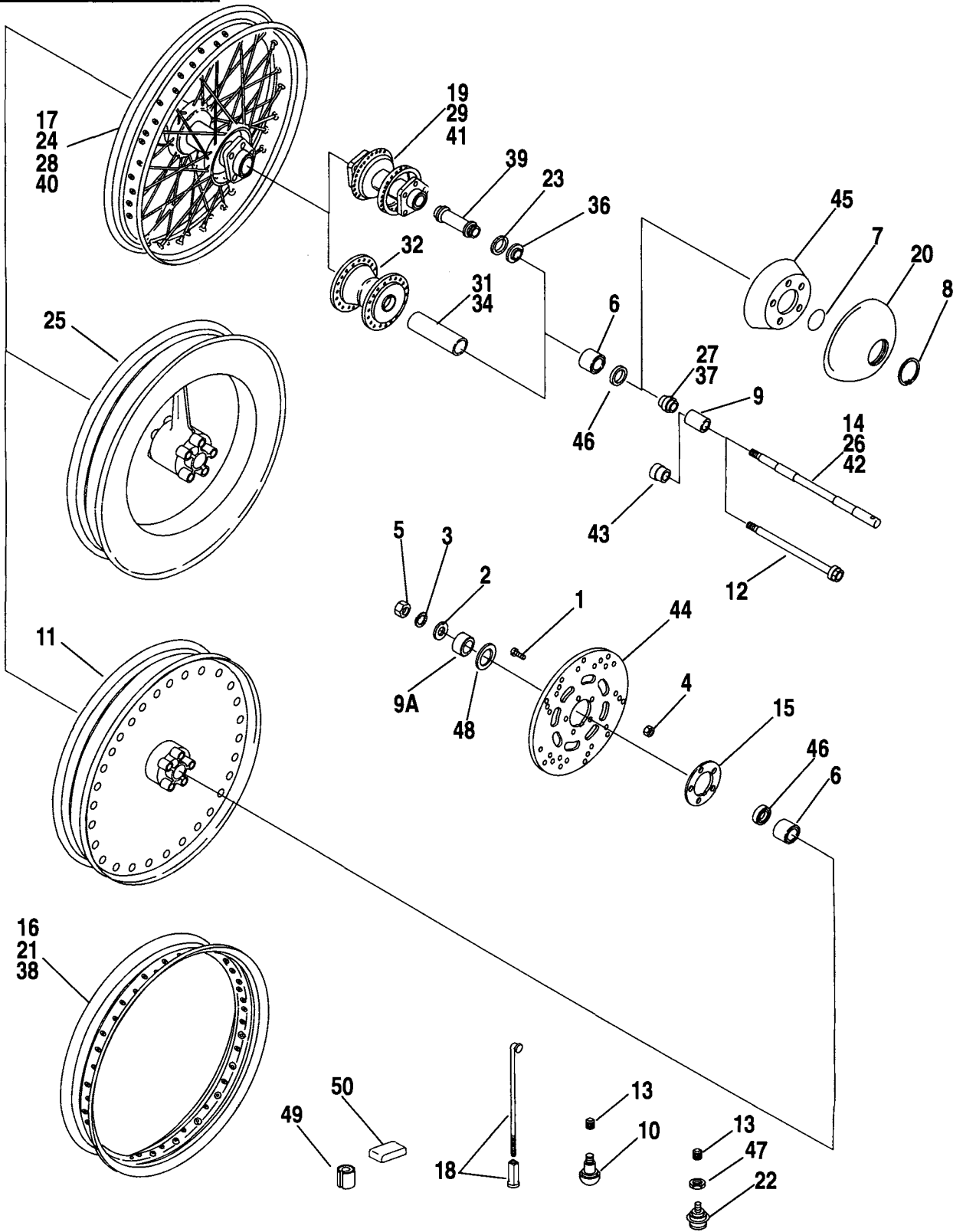

INDEX NO.	PART NO.	DESCRIPTION	FLT MODELS	FXR MODELS	SOFTAIL MODELS	DYNA MODELS
26	43346-83	AXLE	93*-ALL	--	93*-BK	93*-GE
27	43358-83A	SPACER, bearing	--	93*-ALL	--	93*-GD/G
28	43403-87	WHEEL ASSEMBLY, 16" laced	93*-ALL	--	--	--
	43557-87	WHEEL ASSEMBLY, 21" laced	--	93*-EL	--	--
	43676-88	WHEEL ASSEMBLY, 21" laced	--	--	93*-BL	--
29	43404-87	HUB ASSEMBLY, with #31	93*-ALL	--	--	--
31	43608-82	SPACER, sleeve (cast wheel only)	93*-ALL	93*-ALL	--	93*-GD/G
32	43610-87	HUB, w/ bearings & seals	--	93*-EL	--	--
	43619-84	HUB, w/ bearings & seals	--	93*-EA	--	--
34	43612-92	SLEEVE	--	--	93*-BM	--
	43613-92	SLEEVE	--	93*-ALL	--	93*-GD/G
36	43650-82	SPACER WASHER	93*-ALL	93*-ALL	93*-ALL	93*-ALL
37	43654-86A	SPACER	93*-ALL	--	93*-BJ/K/ M/N	--
38	43662-80B	RIM, 21" (chrome)	--	93*-EL	93*-BJ/K/ L/N	93*-GE
39	43668-82	SLEEVE (laced only)	93*-ALL	--	93*-BJ/K/ L/N	93*-GE
40	43671-84	WHEEL ASSEMBLY, 21" laced	--	--	93*-BK	93*-GE
41	43672-84	HUB, w/ bearings & seals	--	--	93*-BK	93*-GE
	43677-88	HUB,w/ bearings & seals	--	--	93*-BL	--
42	43895-87	AXLE	--	93*-ALL	--	93*-GD/G
43	44029-88	SPACER, hub - right	--	--	93*-BL	--
44	44136-92	BRAKE DISC (2 - dual calipers)	93*-ALL	93*-ALL	93*-ALL	93*-ALL
45	44447-89	COVER, disc wheel	--	--	E93-BM	--
	44447-92	COVER, disc wheel	--	--	L93*-BM	--
46	47519-83A	OIL SEAL (2)	93*-ALL	93*-ALL	93*-ALL	93*-ALL
47	54321-85	NUT, valve stem	93*-ALL	93*-EL	93*-BJ/K/ L/N	93*-GE
48	67098-87	SEAL	94*-FD	--	--	--
49	95578-41	WEIGHT, 1/2 oz. - 0.275" I.D. - round	93*-ALL	93*-EA/L	93*-BK/L/N	93*-GE
	95581-47	WEIGHT, 3/4 oz. - 0.275" I.D. - round	93*-ALL	93*-EA/L	93*-BK/L/N	93*-GE
	95582-47	WEIGHT, 1 oz. - 0.275" I.D. - round	93*-ALL	93*-EA/L	93*-BK/L/N	93*-GE
50	95594-84	WEIGHT, 1/4 oz. for cast wheel (black)	93*-ALL	93*-EA	--	93*-GD/G
	95595-84	WEIGHT, 1/4 oz. for cast wheel (silver)	--	93*-EG/L	93*-BM	--

FLT MODELS

FLHTC DJ
 FLTC-U DM
 FLHTC-U DP
 FLHS FA
 FLHR FD

FXR MODELS

FXR EA
 FXRS-SP EG
 FXLR EL
 FXRS-CON EM

SOFTAIL MODELS

FLSTC BJ
 FXSTC BK
 FXSTS BL
 FLSTF BM
 FLSTN BN

DYNA MODELS

FXDL GD
 FXDWG GE
 FXDS-CON GG

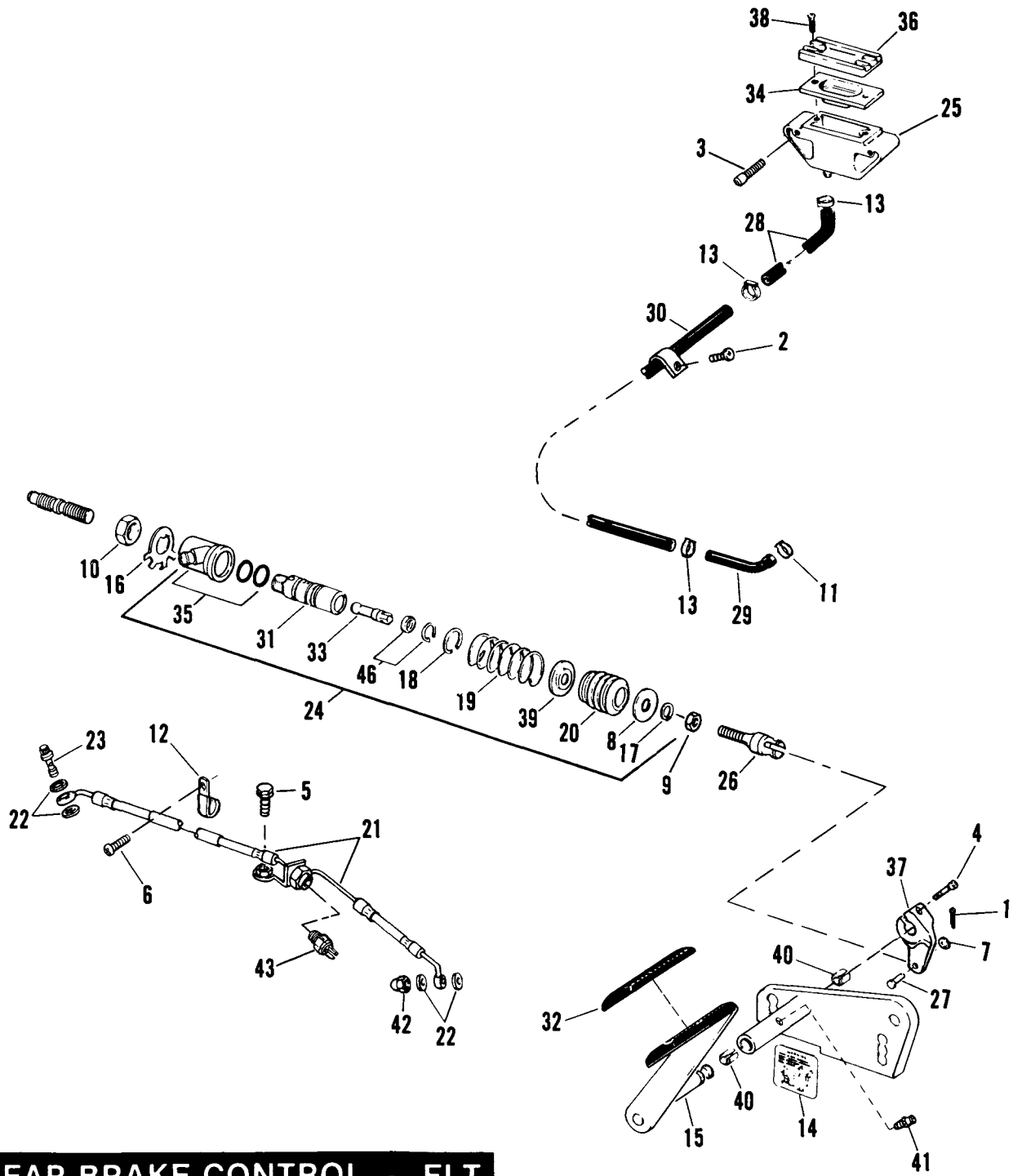

REAR BRAKE CONTROL — FLT

INDEX NO.	PART NO.	DESCRIPTION	FLT MODELS	FXR MODELS	SOFTAIL MODELS	DYNA MODELS
1	515	COTTER PIN	93*-ALL	--	--	--
2	2523	SCREW (2)	93*-ALL	--	--	--
3	3380	SCREW (2)	93*-ALL	--	--	--
4	2708A	BOLT	93*-ALL	--	--	--
5	3588	SCREW	93*-ALL	--	--	--
6	4091	SCREW	93*-ALL	--	--	--
7	6220W	WASHER	93*-ALL	--	--	--
8	6366	WASHER	93*-ALL	--	--	--
9	7744	NUT	93*-ALL	--	--	--
10	7855W	NUT, master cylinder	93*-ALL	--	--	--
11	10014	CLAMP	93*-ALL	--	--	--
12	10031	CLAMP	93*-ALL	--	--	--
13	10038	CLAMP, brake hose (3)	93*-ALL	--	--	--
14	14027-92	LABEL, brake adjustment	93*-ALL	--	--	--
15	33882-83B	FOOT BRAKE LEVER	93*-ALL	--	--	--
16	37503-41	LOCKWASHER	93*-ALL	--	--	--
17	40903-87	RETAINING RING	93*-ALL	--	--	--
18	40918-87	RETAINING RING	93*-ALL	--	--	--
19	40920-87	SPRING, brake rod return	93*-ALL	--	--	--
20	40922-87	BOOT, master cylinder	93*-ALL	--	--	--
21	40971-93	BRAKE HOSE, rear	93*-ALL	--	--	--
22	41731-88A	GASKET (4)	93*-ALL	--	--	--
23	41747-82A	BOLT	93*-ALL	--	--	--
24	41755-92	MASTER CYLINDER	93*-ALL	--	--	--
25	41804-84A	RESERVOIR, master cylinder	93*-ALL	--	--	--
26	41957-92	PUSH ROD	93*-ALL	--	--	--
27	42460-80B	CLEVIS PIN	93*-ALL	--	--	--
28	42310-93	HOSE, reservoir	93*-ALL	--	--	--
29	42315-92	HOSE, reservoir	93*-ALL	--	--	--
30	42322-93	TUBE, reservoir	93*-ALL	--	--	--
31	42382-87A	REBUILD KIT, master cylinder	93*-ALL	--	--	--
32	42416-83	PAD, brake pedal	93*-ALL	--	--	--
33	42448-87	PUSH ROD	93*-ALL	--	--	--
34	42455-80	GASKET, master cylinder reservoir	93*-ALL	--	--	--
35	42457-92	REPAIR KIT, res. adaptor	93*-ALL	--	--	--
36	45057-82	COVER, reservoir	93*-ALL	--	--	--
37	42510-92	CLEVIS ASSEMBLY	93*-ALL	--	--	--
38	42534-90	SCREW (2)	93*-ALL	--	--	--
39	44126-87	RETAINER, brake return spring	93*-ALL	--	--	--
40	47247-83	BUSHING, hub foot brake (2)	93*-ALL	--	--	--
41	50972-75	FITTING, lubrication	93*-ALL	--	--	--
42	54307-92	ACORN NUT, brake	93*-ALL	--	--	--
43	72023-51A	SWITCH, stoplamp	93*-ALL	--	--	--

FLT MODELS

FLHTC DJ
 FLTC-U DM
 FLHTC-U DP
 FLHS FA
 FLHR FD

FXR MODELS

FXR EA
 FXRS-SP EG
 FXLR EL
 FXRS-CON EM

SOFTAIL MODELS

FLSTC BJ
 FXSTC BK
 FXSTS BL
 FLSTF BM
 FLSTN BN

DYNA MODELS

FXDL GD
 FXDWG GE
 FXDS-CON GG

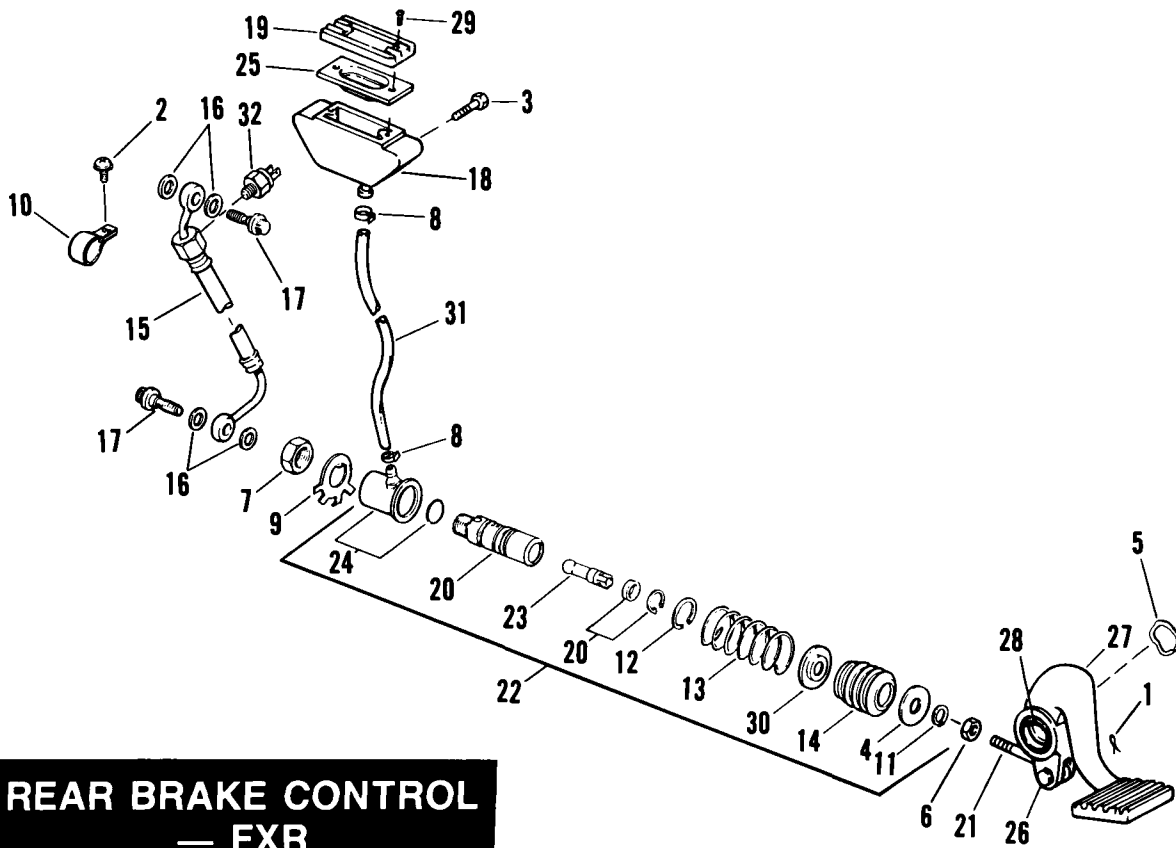

**REAR BRAKE CONTROL
— FXR**

REAR BRAKE CONTROL - FXR MODELS

FB22A

INDEX NO.	PART NO.	DESCRIPTION	FLT MODELS	FXR MODELS	SOFTAIL MODELS	DYNA MODELS
1	515	COTTER PIN	--	93*-ALL	--	--
2	2501A	SCREW	--	93*-ALL	--	--
3	3473	BOLT (2)	--	93*-ALL	--	--
4	6366	WASHER	--	93*-ALL	--	--
5	7012	WASHER	--	93*-ALL	--	--
6	7744	NUT	--	93*-ALL	--	--
7	7855W	NUT	--	93*-ALL	--	--
8	10038	CLAMP (2)	--	93*-ALL	--	--
9	37503-41	LOCKWASHER	--	93*-ALL	--	--
10	38712-68	CLAMP	--	93*-ALL	--	--
11	40903-87	RETAINING RING	--	93*-ALL	--	--
12	40918-87	RETAINING RING	--	93*-ALL	--	--
13	40920-87	SPRING, brake return	--	93*-ALL	--	--
14	40922-87	BOOT, master cylinder	--	93*-ALL	--	--
15	40956-87	BRAKE LINE, rear	--	93*-ALL	--	--
16	41731-88A	GASKET (4)	--	93*-ALL	--	--
17	41747-82A	BOLT (2)	--	93*-ALL	--	--
18	41804-84A	RESERVOIR, master cylinder	--	93*-ALL	--	--
19	45057-82	COVER, reservoir	--	93*-ALL	--	--
20	42382-87A	REPAIR KIT, master cylinder	--	93*-ALL	--	--
21	42437-87	ROD END	--	93*-ALL	--	--
22	42446-87A	MASTER CYLINDER, rear	--	93*-ALL	--	--
23	42448-87	PUSH ROD	--	93*-ALL	--	--
24	42452-87	REPAIR KIT, master cylinder body	--	93*-ALL	--	--
25	42455-80	GASKET, reservoir	--	93*-ALL	--	--
26	42460-80B	CLEVIS PIN	--	93*-ALL	--	--
27	42523-87	BRAKE PEDAL ASM., w/ #1, 21, 26 & 28	--	93*-ALL	--	--
28	42524-82	BUSHING (2)	--	93*-ALL	--	--
29	42534-90	SCREW (2)	--	93*-ALL	--	--
30	44126-87	RETAINER, brake return spring	--	93*-ALL	--	--
31	63561-87	HOSE, reservoir to master cylinder	--	93*-ALL	--	--
32	72023-51A	STOPLAMP SWITCH	--	93*-ALL	--	--

FLT MODELS

FLHTC DJ
 FLTC-U DM
 FLHTC-U DP
 FLHS FA
 FLHR FD

FXR MODELS

FXR EA
 FXRS-SP EG
 FXLR EL
 FXRS-CON EM

SOFTAIL MODELS

FLSTC BJ
 FXSTC BK
 FXSTS BL
 FLSTF BM
 FLSTN BN

DYNA MODELS

FXDL GD
 FXDWG GE
 FXDS-CON GG

REAR BRAKE CONTROL - FXST

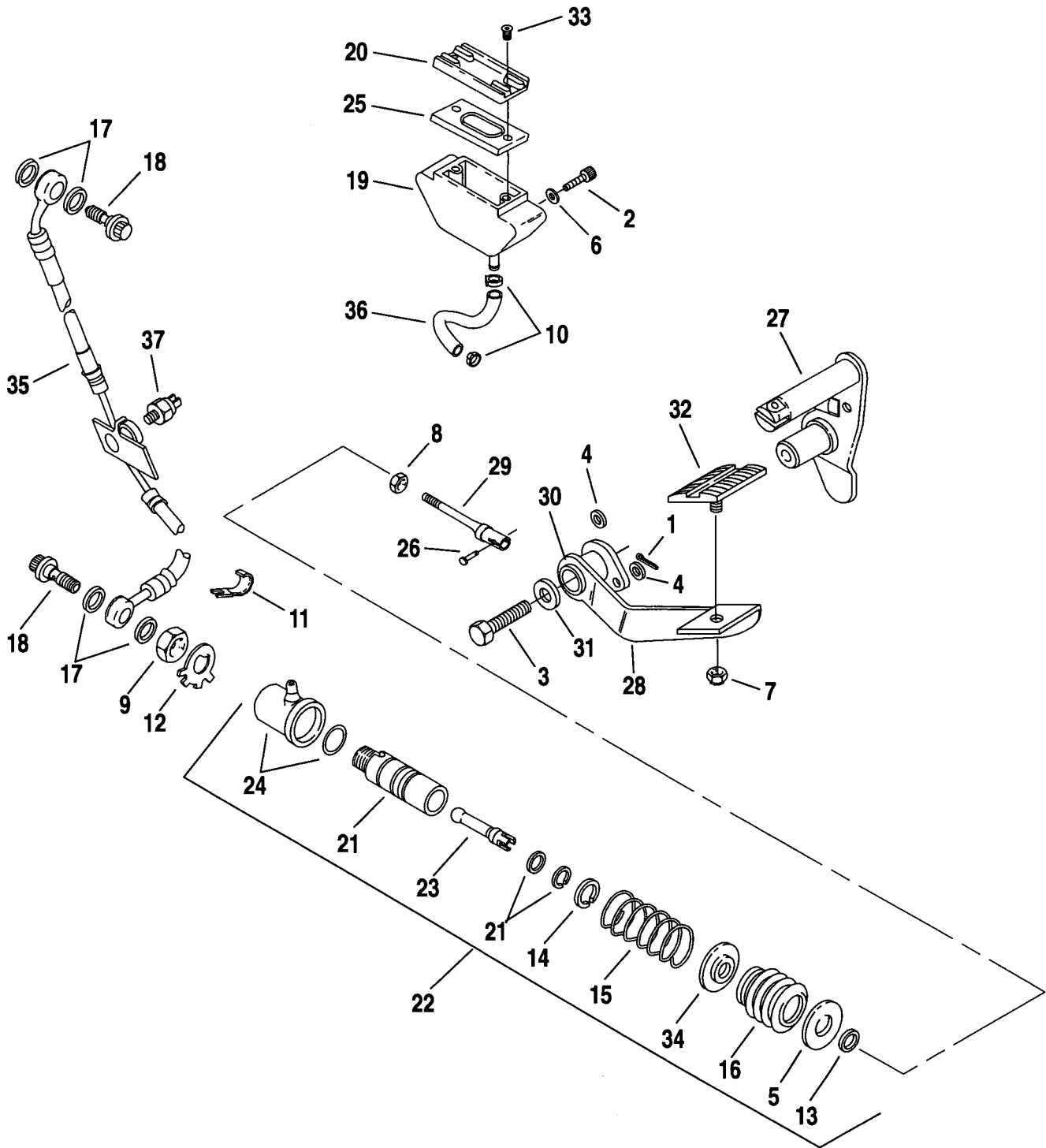

INDEX NO.	PART NO.	DESCRIPTION	FLT MODELS	FXR MODELS	SOFTAIL MODELS	DYNA MODELS
1	515	COTTER PIN	--	--	93*-BK/L	--
2	3473	BOLT (2)	--	--	93*-BK/L	--
3	3509	SCREW	--	--	93*-BK/L	--
4	6099	WASHER (2)	--	--	93*-BK/L	--
5	6366	WASHER	--	--	93*-BK/L	--
6	6716	WASHER (2)	--	--	93*-BK/L	--
7	7742	LOCKNUT	--	--	93*-BK/L	--
8	7744	JAM NUT	--	--	93*-BK/L	--
9	7855W	NUT	--	--	93*-BK/L	--
10	10038	CLAMP, reservoir hose (2)	--	--	93*-BK/L	--
11	10122	CLIP	--	--	93*-BK/L	--
12	37503-41	LOCKWASHER	--	--	93*-BK/L	--
13	40903-87	RETAINING RING	--	--	93*-BK/L	--
14	40918-87	RETAINING RING	--	--	93*-BK/L	--
15	40920-87	SPRING, brake return	--	--	93*-BK/L	--
16	40922-87	BOOT, push rod	--	--	93*-BK/L	--
17	41731-88A	GASKET (4)	--	--	93*-BK/L	--
18	41747-82A	BOLT (2)	--	--	93*-BK/L	--
19	41804-84A	RESERVOIR, master cylinder	--	--	93*-BK/L	--
20	45057-82	COVER, reservoir	--	--	93*-BK/L	--
21	42382-87A	REPAIR KIT, master cylinder	--	--	93*-BK/L	--
22	42446-87A	MASTER CYLINDER ASSEMBLY	--	--	93*-BK/L	--
23	42448-87	PUSH ROD, master cylinder	--	--	93*-BK/L	--
24	42452-87	REPAIR KIT, master cylinder body	--	--	93*-BK/L	--
25	42455-80	GASKET, reservoir	--	--	93*-BK/L	--
26	42460-80B	PIN, rear brake rod clevis	--	--	93*-BK/L	--
27	42507-89A	BRACKET, brake lever & footrest	--	--	93*-BK/L	--
28	42515-82	LEVER, foot brake (chrome)	--	--	93*-BK/L	--
29	42522-87	CLEVIS, brake rod	--	--	93*-BK/L	--
30	42524-82	BUSHING (2)	--	--	93*-BK/L	--
31	42531-87	WASHER	--	--	93*-BK/L	--
32	42532-82	PAD, brake lever	--	--	93*-BK/L	--
33	42534-90	SCREW (2)	--	--	93*-BK/L	--
34	44126-87	RETAINER, return spring	--	--	93*-BK/L	--
35	45156-89C	REAR BRAKE HOSE	--	--	93*-BK/L	--
36	63546-87	HOSE, reservoir	--	--	93*-BK/L	--
37	72023-51A	STOPLAMP SWITCH, rear	--	--	93*-BK/L	--

FLT MODELS

FLHTC
FLTC-U
FLHTC-U
FLHS
FLHR

DJ
DM
DP
FA
FD

FXR MODELS

FXR
FXRS-SP
FXLR
FXRS-CON

EA
EG
EL
EM

SOFTAIL MODELS

FLSTC
FXSTC
FXSTS
FLSTF
FLSTN

BJ
BK
BL
BM
BN

DYNA MODELS

FXDL
FXDWG
FXDS-CON

GD
GE
GG

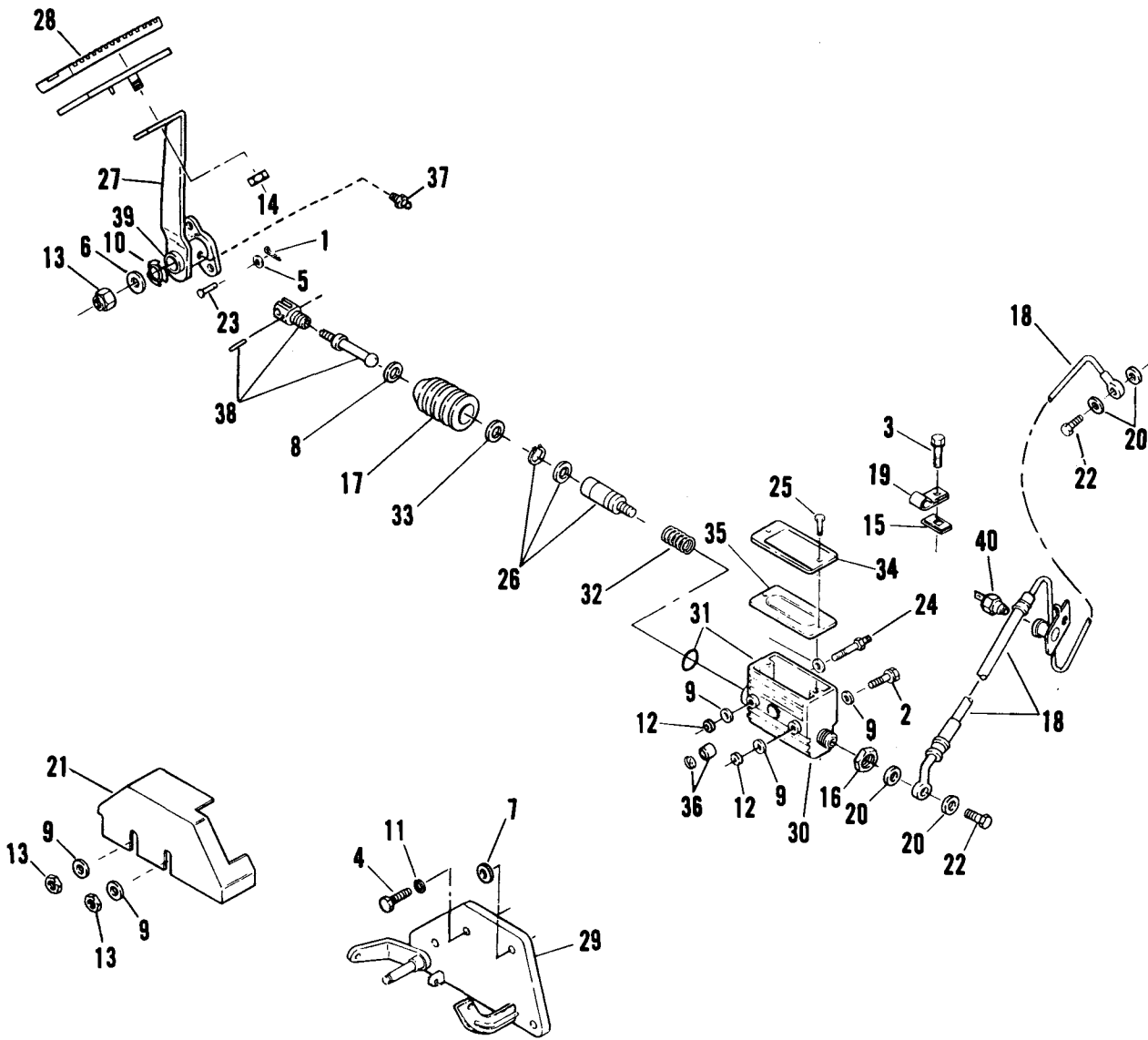

**REAR BRAKE CONTROL
— FLST**

REAR BRAKE CONTROL - FLST MODELS

FB22C

INDEX NO.	PART NO.	DESCRIPTION	FLT MODELS	FXR MODELS	SOFTAIL MODELS	DYNA MODELS
1	515	COTTER PIN	--	--	93*-BJ/M/N	--
2	3787	BOLT	--	--	93*-BJ/M/N	--
3	4068	BOLT	--	--	93*-BJ/M/N	--
4	4713W	BOLT	--	--	93*-BJ/M/N	--
5	6220W	WASHER	--	--	93*-BJ/M/N	--
6	6334	WASHER	--	--	93*-BJ/M/N	--
7	6352	WASHER	--	--	93*-BJ/M/N	--
8	6366	WASHER	--	--	93*-BJ/M/N	--
9	6702	WASHER (3)	--	--	93*-BJ/M/N	--
10	7007	SPRING WASHER	--	--	93*-BJ/M/N	--
11	7038	LOCKWASHER	--	--	93*-BJ/M/N	--
12	7740	NUT (2)	--	--	93*-BJ/M/N	--
13	7748W	NUT (2)	--	--	93*-BJ/M/N	--
14	7825	LOCKNUT	--	--	93*-BJ/M/N	--
15	8108	CLIP NUT	--	--	93*-BJ/M/N	--
16	35078-79	LOCKNUT	--	--	93*-BJ/M/N	--
17	40922-87	BOOT, push rod	--	--	93*-BJ/M/N	--
18	40957-87A	BRAKE LINE	--	--	93*-BJ/M/N	--
19	41713-86	CLAMP, rear brake line	--	--	93*-BJ/M/N	--
20	41731-88A	GASKET (4)	--	--	93*-BJ/M/N	--
21	41745-79	COVER, master cylinder (chrome)	--	--	93*-BJ/M/N	--
22	41747-82A	BOLT (2)	--	--	93*-BJ/M/N	--
23	42269-30	PIN, rear brake rod clevis	--	--	93*-BJ/M/N	--
24	42301-87	STUD, master cylinder	--	--	93*-BJ/M/N	--
25	42375-87	SCREW, master cylinder cover (2)	--	--	93*-BJ/M/N	--
26	42382-87A	REPAIR KIT, master cylinder	--	--	93*-BJ/M/N	--
27	42407-87B	LEVER, foot brake (chrome)	--	--	93*-BJ/M/N	--
28	42416-83	PAD, brake lever	--	--	93*-BJ/M/N	--
29	42431-87	SUPPORT, foot brake lever	--	--	93*-BJ/M/N	--
30	42468-87C	MASTER CYLINDER ASSEMBLY	--	--	93*-BJ/M/N	--
31	42473-87	REPAIR KIT, master cylinder body	--	--	93*-BJ/M/N	--
32	42479-90	SPRING	--	--	93*-BJ/M/N	--
33	44126-87	RETAINER, spring	--	--	93*-BJ/M/N	--
34	45004-85	COVER, master cylinder (black)	--	--	93*-BJ/M/N	--
35	45005-85	GASKET, cover	--	--	93*-BJ/M/N	--
36	45042-82	REPAIR KIT, sight glass	--	--	93*-BJ/M/N	--
37	50972-75	FITTING, lubrication	--	--	93*-BJ/M/N	--
38	50992-87	ROD END, master cylinder	--	--	93*-BJ/M/N	--
39	57215-75	BUSHING, foot brake lever (2)	--	--	93*-BJ/M/N	--
40	72023-51A	STOPLAMP SWITCH, rear	--	--	93*-BJ/M/N	--

FLT MODELS

FLHTC
FLTC-U
FLHTC-U
FLHS
FLHR

DJ
DM
DP
FA
FD

FXR MODELS

FXR
FXRS-SP
FXLR
FXRS-CON
EA
EG
EL
EM

SOFTAIL MODELS

FLSTC
FXSTC
FXSTS
FLSTF
FLSTN
BJ
BK
BL
BM
BN

DYNA MODELS

FXDL
FXDWG
FXDS-CON
GD
GE
GG

REAR BRAKE CONTROL - DYNA

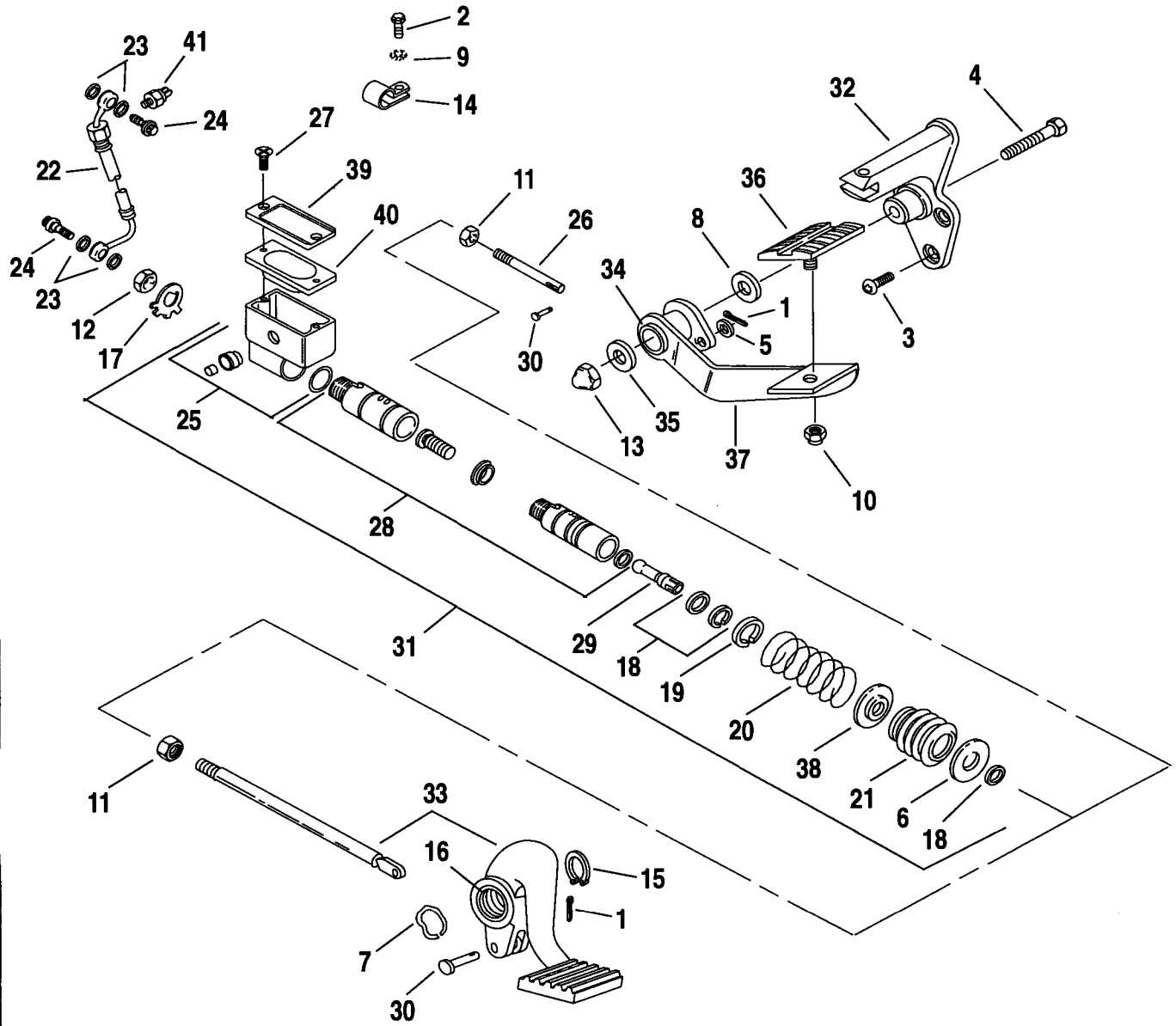

REAR BRAKE CONTROL - DYNA

FB22D

INDEX NO.	PART NO.	DESCRIPTION	FLT MODELS	FXR MODELS	SOFTAIL MODELS	DYNA MODELS
1	515	COTTER PIN	--	--	--	93*-ALL
2	3537	SCREW	--	--	--	93*-ALL
3	4059	SCREW(2)	--	--	--	93*-GE
4	4713W	BOLT	--	--	--	93*-GE
5	6099	WASHER	--	--	--	93*-GE
6	6366	WASHER	--	--	--	93*-ALL
7	7003	WASHER, spring	--	--	--	93*-GD/G
8	7009	WASHER, spring	--	--	--	93*-GE
9	7229W	LOCKWASHER	--	--	--	93*-ALL
10	7742	LOCKNUT	--	--	--	93*-GE
11	7744	NUT	--	--	--	93*-ALL
12	7855W	NUT	--	--	--	93*-ALL
13	7862	ACORN NUT, locking	--	--	--	93*-GE
14	10053	CLAMP	--	--	--	93*-ALL
15	11005	RETAINING RING	--	--	--	93*-GD/G
16	33714-90	BEARING (2)	--	--	--	93*-GD/G
17	37503-41	LOCKWASHER	--	--	--	93*-ALL
18	40903-87	RETAINING RING	--	--	--	93*-ALL
19	40918-87	RETAINING RING	--	--	--	93*-ALL
20	40920-87	SPRING	--	--	--	93*-ALL
21	40922-87	BOOT	--	--	--	93*-ALL
22	40956-90	BRAKE LINE	--	--	--	93*-ALL
23	41731-88A	GASKET (4)	--	--	--	93*-ALL
24	41747-82A	BOLT (2)	--	--	--	93*-ALL
25	41803-90	RESERVOIR ASM.	--	--	--	93*-ALL
26	41955-93	PUSH ROD	--	--	--	93*-GE
27	42375-87	SCREW (2)	--	--	--	93*-ALL
28	42382-87A	REPAIR KIT, master cylinder	--	--	--	93*-ALL
29	42448-87	PUSH ROD	--	--	--	93*-ALL
30	42460-80B	CLEVIS PIN	--	--	--	93*-ALL
31	42474-90A	MASTER CYLINDER	--	--	--	93*-ALL
32	42481-92	BRACKET, brake lever & footrest	--	--	--	93*-GE
33	42502-90A	BRAKE PEDAL ASM.	--	--	--	93*-GD/G
34	42524-82	BUSHING, brake lever (2)	--	--	--	93*-GE
35	42531-87	WASHER	--	--	--	93*-GE
36	42532-82	PAD, brake pedal	--	--	--	93*-GE
37	42542-93	BRAKE PEDAL ASM.	--	--	--	93*-GE
38	44126-87	SPRING RETAINER	--	--	--	93*-ALL
39	45004-85	COVER, master cylinder	--	--	--	93*-ALL
40	45005-85	GASKET, cover	--	--	--	93*-ALL
41	72023-51A	STOPLAMP SWITCH	--	--	--	93*-ALL

FLT MODELS

FLHTC DJ
 FLTC-U DM
 FLHTC-U DP
 FLHS FA
 FLHR FD

FXR MODELS

FXR EA
 FXRS-SP EG
 FXLR EL
 FXRS-CON EM

SOFTAIL MODELS

FLSTC BJ
 FXSTC BK
 FXSTS BL
 FLSTF BM
 FLSTN BN

DYNA MODELS

FXDL GD
 FXDWG GE
 FXDS-CON GG

REAR BRAKE CALIPER

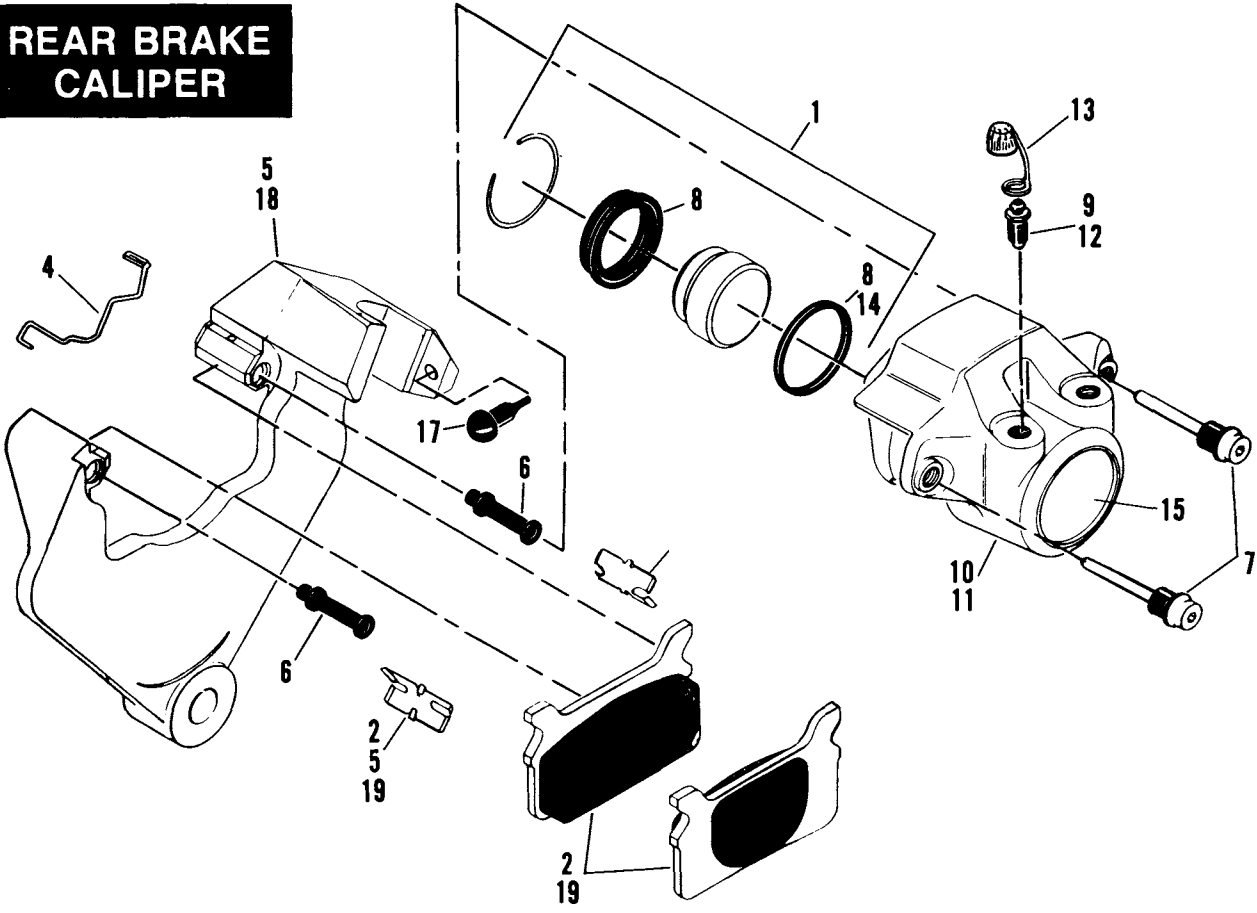

INDEX NO.	PART NO.	DESCRIPTION	FLT MODELS	FXR MODELS	SOFTAIL MODELS	DYNA MODELS
1	43946-86	PISTON KIT, w/# 14	93*-ALL	93*-ALL	93*-ALL	--
2	43957-86E	PAD SET w/ inserts	93*-ALL	--	--	--
4	43960-86	RETAINER	93*-ALL	93*-ALL	93*-ALL	--
5	44034-86	BRACKET, w/ # 6, 17, & inserts	93*-ALL	--	--	--
6	44035-86A	BUSHING (2)	93*-ALL	93*-ALL	93*-ALL	--
7	44039-86	MOUNTING KIT, w/ guide pins & bushings	93*-ALL	93*-ALL	93*-ALL	--
8	44045-87	SEAL & BOOT KIT	93*-ALL	93*-ALL	93*-ALL	--
9	44048-83	BLEEDER FITTING	93*-ALL	93*-ALL	93*-ALL	--
10	44050-87	CALIPER ASSEMBLY, without bracket	--	93*-ALL	93*-ALL	--
11	44076-86A	CALIPER ASSEMBLY, without bracket	93*-ALL	--	--	--
12	44146-77	BLEEDER FITTING	--	93*-ALL	93*-ALL	--
13	44147-87	CAP, bleeder screw	93*-ALL	93*-ALL	93*-ALL	--
14	44152-77	SEAL, piston	93*-ALL	93*-ALL	93*-ALL	--
15	44198-87	LABEL	--	93*-ALL	93*-ALL	--
17	44199-79	BUMPER	93*-ALL	93*-ALL	93*-ALL	--
18	44205-87	BRACKET, mounting w/ # 6, 17 & shims	--	93*-ALL	--	--
	44207-87	BRACKET, mounting w/ # 6, 17 & shims	--	--	93*-ALL	--
19	44209-87C	PAD SET w/ inserts	--	93*-ALL	93*-ALL	--

FLT MODELS

FLHTC DJ
 FLTC-U DM
 FLHTC-U DP
 FLHS FA
 FLHR FD

FXR MODELS

FXR EA
 FXRS-SP EG
 FXLR EL
 FXRS-CON EM

SOFTAIL MODELS

FLSTC BJ
 FXSTC BK
 FXSTS BL
 FLSTF BM
 FLSTN BN

DYNA MODELS

FXDL GD
 FXDWG GE
 FXDS-CON GG

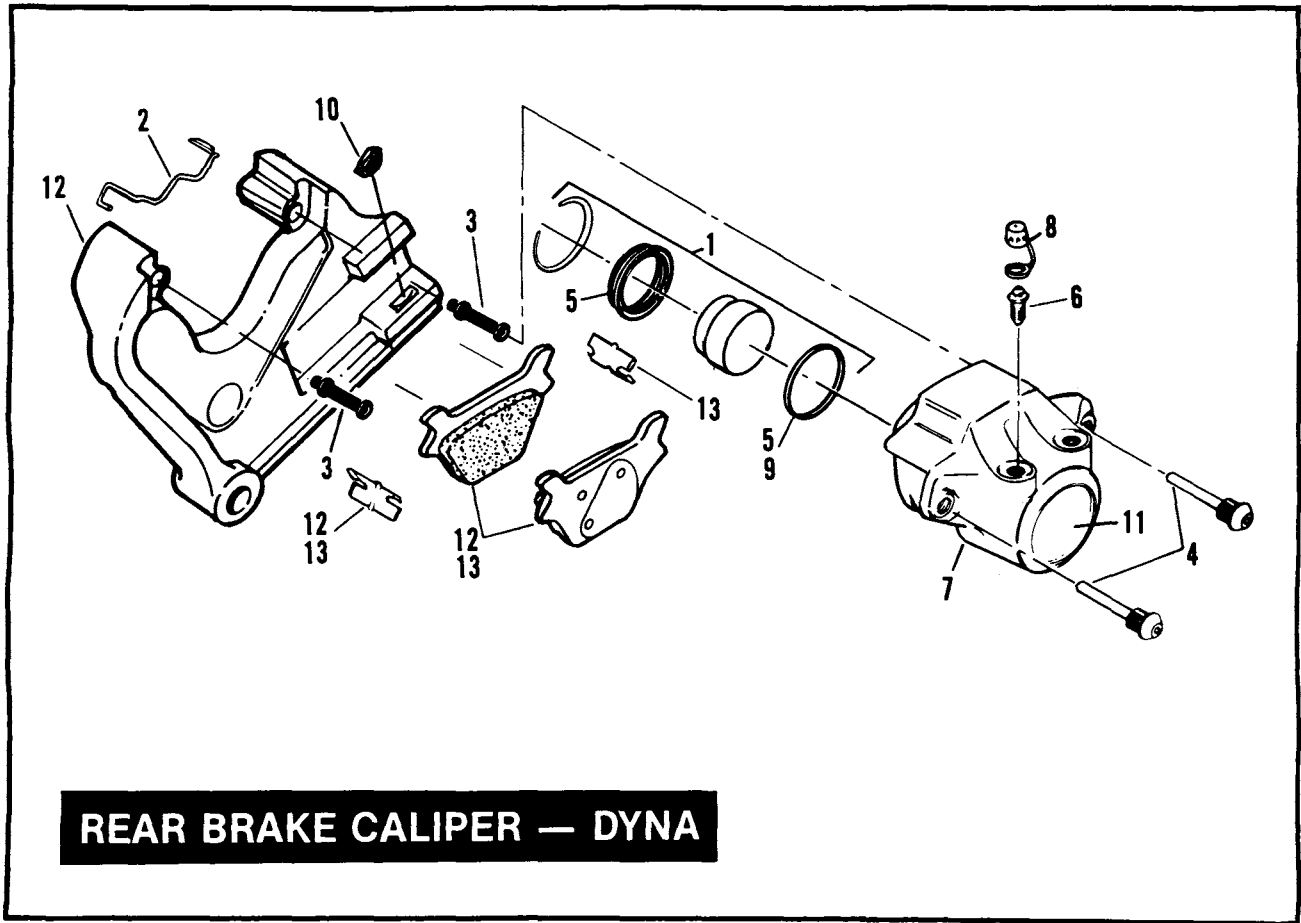

REAR BRAKE CALIPER - DYNA

FB23A

INDEX NO.	PART NO.	DESCRIPTION	FLT MODELS	FXR MODELS	SOFTAIL MODELS	DYNA MODELS
1	43946-86	PISTON KIT w/ #9	--	--	--	93*-ALL
2	43960-86	RETAINER	--	--	--	93*-ALL
3	44035-86A	BUSHING (2)	--	--	--	93*-ALL
4	44039-86	MOUNTING KIT w/ #12	--	--	--	93*-ALL
5	44045-87	SEAL & BOOT KIT	--	--	--	93*-ALL
6	44048-83	SCREW, bleeder	--	--	--	93*-ALL
7	44050-87	CALIPER ASSEMBLY, without bracket	--	--	--	93*-ALL
8	44147-87	CAP, bleeder screw	--	--	--	93*-ALL
9	44152-77	BOOT	--	--	--	93*-ALL
10	44196-90	BUMPER	--	--	--	93*-ALL
11	44198-87	CALIPER INSERT	--	--	--	93*-ALL
12	44204-90	BRACKET, mounting w/ #3,10 & insert	--	--	--	93*-ALL
13	44209-87C	PAD SET w/ inserts	--	--	--	93*-ALL

FLT MODELS

FLHTC DJ
 FLTC-U DM
 FLHTC-U DP
 FLHS FA
 FLHR FD

FXR MODELS

FXR EA
 FXRS-SP EG
 FXLR EL
 FXRS-CON EM

SOFTAIL MODELS

FLSTC BJ
 FXSTC BK
 FXSTS BL
 FLSTF BM
 FLSTN BN

DYNA MODELS

FXDL GD
 FXDWG GE
 FXDS-CON GG

REAR WHEEL

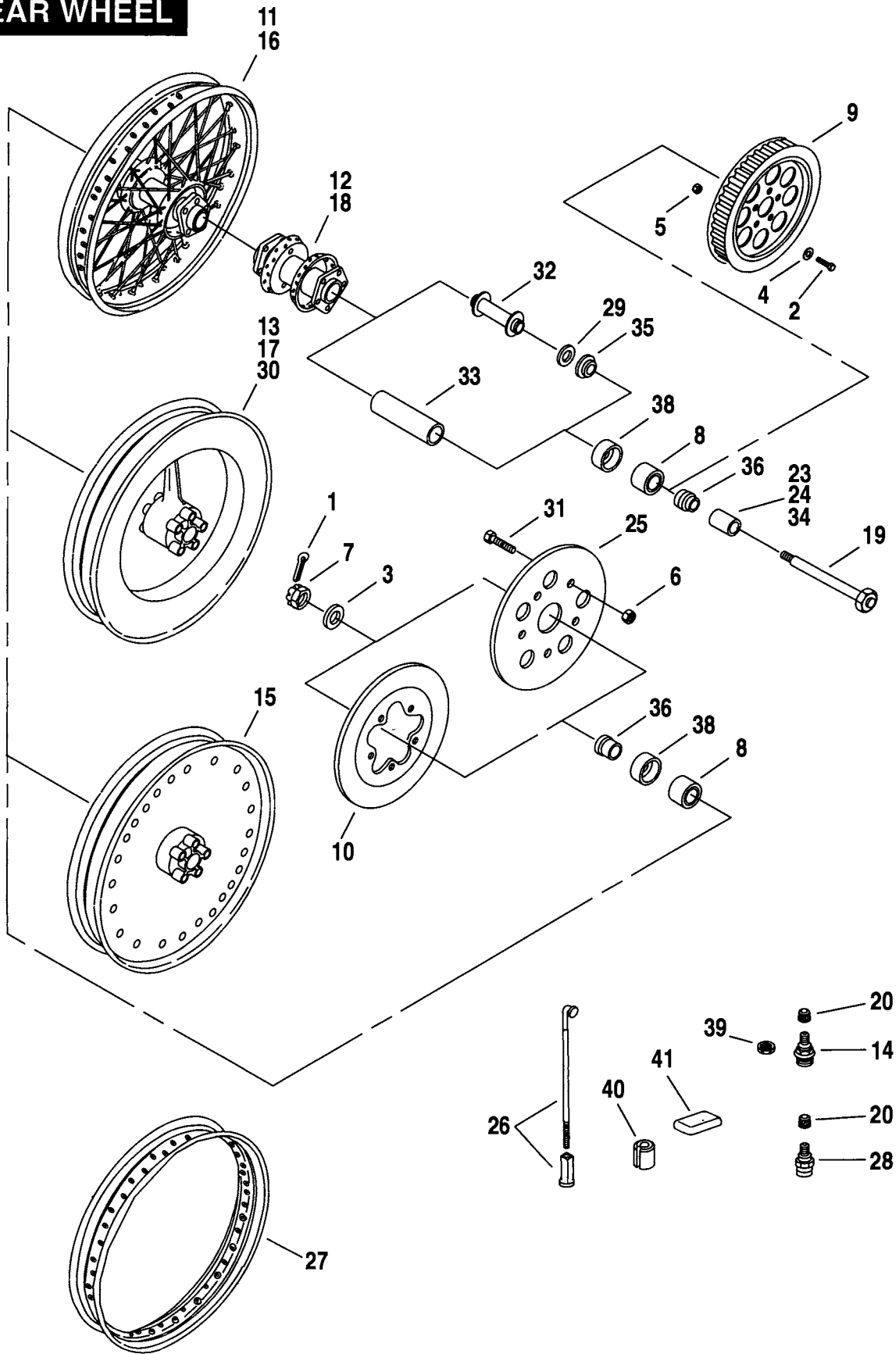

REAR WHEEL

FB24-1

INDEX NO.	PART NO.	DESCRIPTION	FLT MODELS	FXR MODELS	SOFTAIL MODELS	DYNA MODELS
1	511	COTTER PIN	93*-ALL	93*-ALL	93*-ALL	93*-ALL
2	3730A	BOLT (5) (cast wheels only)	93*-ALL	93*-ALL	93*-ALL	93*-GD
	3769	BOLT (5) (laced wheels only)	93*-ALL	93*-EA	93*-ALL	93*-GE
3	5756	SPACER	93*-ALL	93*-ALL	93*-ALL	93*-ALL
4	6516HW	WASHER (5)	93*-ALL	--	93*-ALL	93*-ALL
5	7827W	NUT (5)	93*-ALL	93*-EA	93*-ALL	93*-GE
6	7778	LOCKNUT (5)	--	93*-EA	93*-BJ/L/N	--
7	7987	CASTLE NUT	93*-ALL	93*-ALL	93*-ALL	93*-ALL
8	9052	ROLLER BEARING (2)	93*-ALL	93*-ALL	93*-ALL	93*-ALL
9	40217-79A	SPROCKET, 70T (black)	93*-ALL	93*-EA	94*-BJ/L/N	93*-ALL
	40221-85A	SPROCKET, 70T (silver)	--	93*-EG/L/M	94*-BK/M	--
	40236-88A	SPROCKET, 61T (silver)	--	--	93*-BK/M	--
	40237-88A	SPROCKET, 61T (black)	--	--	93*-BJ/L/N	--
10	40939-86A	BRAKE DISC	93*-ALL	--	--	--
11	40975-86	WHEEL ASSEMBLY, 16" - laced (chrome)	--	93*-EA	93*-BJ/L/N	93*-GE
12	40976-86	HUB ASSEMBLY, w/ spacer	--	93*-EA	93*-BJ/L/N	93*-GE
13	40983-86	WHEEL ASSEMBLY, cast - 9 spoke (silver)	--	93*-EG/M	--	--
14	40999-87	VALVE STEM	93*-ALL	--	--	--
15	41008-87A	DISC WHEEL	--	93*-EL	93*-BK/M	--
16	41010-86	WHEEL ASSEMBLY, 16" - laced	93*-ALL	--	--	--
17	41015-86	WHEEL ASSEMBLY, cast - 9 spoke (black)	--	93*-EA	--	93*-GD/G
18	41020-86	HUB ASSEMBLY, laced wheel, w/ spacer	93*-ALL	--	--	--
19	41110-79A	AXLE ASSEMBLY	93*-ALL	93*-ALL	93*-ALL	--
	41114-90	AXLE	--	--	--	93*-ALL
20	41123-79	VALVE CAP	93*-ALL	93*-ALL	93*-ALL	93*-ALL
23	41591-90	SPACER, rear axle - left	--	--	--	93*-ALL
24	41595-86	SPACER, rear axle - left	--	--	93*-ALL	--
25	41789-92	DISC, brake w/# 31	--	93*-ALL	93*-ALL	93*-ALL
26	43032-40B	SPOKE & NIPPLE SET, 16" rim (40)	93*-ALL	93*-EA	93*-BJ/L/N	93*-GE
27	43085-81	RIM, 16" (chrome)	93*-ALL	93*-EA	93*-BJ/L/N	93*-GE
28	43157-83A	VALVE STEM ASSEMBLY	--	93*-EA	--	93*-GD/G
29	43290-82	SPACER, 0.032" thk.	93*-ALL	93*-ALL	93*-ALL	93*-ALL
	43291-82	SPACER, 0.016" thk.	93*-ALL	93*-ALL	93*-ALL	93*-ALL
	43292-82	SPACER, 0.008" thk.	93*-ALL	93*-ALL	93*-ALL	93*-ALL
	43293-82	SPACER, 0.004" thk.	93*-ALL	93*-ALL	93*-ALL	93*-ALL
	43294-82	SPACER, 0.002" thk.	93*-ALL	93*-ALL	93*-ALL	93*-ALL
30	43299-87	WHEEL ASSEMBLY, 16" - 10 spoke (black)	93*-ALL	--	--	--

FLT MODELS

FLHTC DJ
 FLTC-U DM
 FLHTC-U DP
 FLHS FA
 FLHR FD

FXR MODELS

FXR
 FXRS-SP EG
 FXLR EL
 FXRS-CON EM

SOFTAIL MODELS

FLSTC BJ
 FXSTC BK
 FXSTS BL
 FLSTF BM
 FLSTN BN

DYNA MODELS

FXDL GD
 FXDWG GE
 FXDS-CON GG

REAR WHEEL

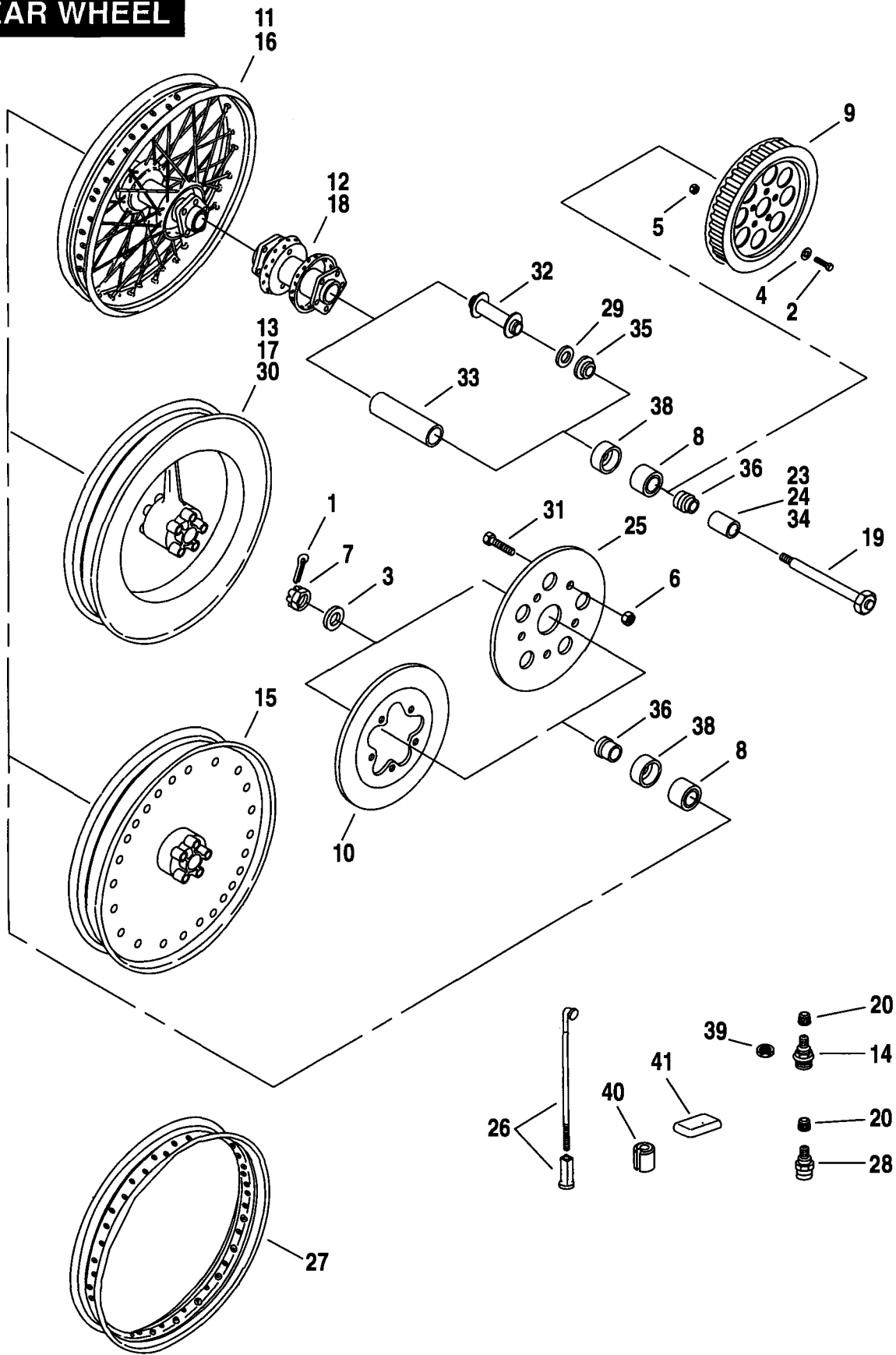

INDEX NO.	PART NO.	DESCRIPTION	FLT MODELS	FXR MODELS	SOFTAIL MODELS	DYNA MODELS
31	43567-92	SCREW (5)	93*-ALL	93*-ALL	93*-ALL	93*-ALL
32	43608-82	SPACER, (cast only)	93*-ALL	93*-ALL	93*-BK/M	93*-GD/G
33	43668-82	SPACER (laced only)	93*-ALL	93*-EA	93*-BJ/L/N	93*-GE
34	43648-86	SPACER, left	93*-ALL	--	--	--
35	43650-82	SPACER WASHER	93*-ALL	93*-ALL	93*-ALL	93*-ALL
36	43654-86A	SPACER (2)	93*-ALL	93*-ALL	93*-ALL	93*-ALL
38	47519-83A	OIL SEAL (2)	93*-ALL	93*-ALL	93*-ALL	93*-ALL
39	54321-85	NUT, valve stem	93*-ALL	93*-EA	93*-BJ/L/N	93*-GE
40	95578-41	WEIGHT, 1/2 oz. - 0.275" I.D. - round	93*-ALL	93*-EA	93*-BJ/L/N	93*-GE
	95581-47	WEIGHT, 3/4 oz. - 0.275" I.D. - round	93*-ALL	93*-EA	93*-BJ/L/N	93*-GE
	95582-47	WEIGHT, 1 oz. - 0.275" I.D. - round	93*-ALL	93*-EA	93*-BJ/L/N	93*-GE
41	95594-84	WEIGHT, 1/4 oz. (black)	93*-ALL	93*-EA	--	93*-GD/G
	95595-84	WEIGHT, 1/4 oz. (silver)	--	93*-EG/L/M	93*-BK/M	--
H-D INTERNATIONAL ONLY						
9	40236-88A	SPROCKET, 61T (silver) (HDI & E1994 Australia Softail Models)	--	93-EG/L/M	E94-BK/M	--
	40237-88A	SPROCKET, 61T (black) (HDI & E1994 Australia Softail Models)	93-ALL	93-EA	E94-BJ/L/N	93-ALL
	40311-94	SPROCKET, 65T (silver)(Swiss & L1994 Australia Softail Models)	--	--	94*-BK/M	--
	40312-94	SPROCKET, 65T (black)(Swiss & L1994 Australia Softail Models)	94*-ALL	94*-ALL	94*-BJ/L/N	94*-ALL

FLT MODELS

FLHTC DJ
 FLTC-U DM
 FLHTC-U DP
 FLHS FA
 FLHR FD

FXR MODELS

FXR EA
 FXRS-SP EG
 FXLR EL
 FXRS-CON EM

SOFTAIL MODELS

FLSTC BJ
 FXSTC BK
 FXSTS BL
 FLSTF BM
 FLSTN BN

DYNA MODELS

FXDL GD
 FXDWG GE
 FXDS-CON GG

FRONT FORK - FLT

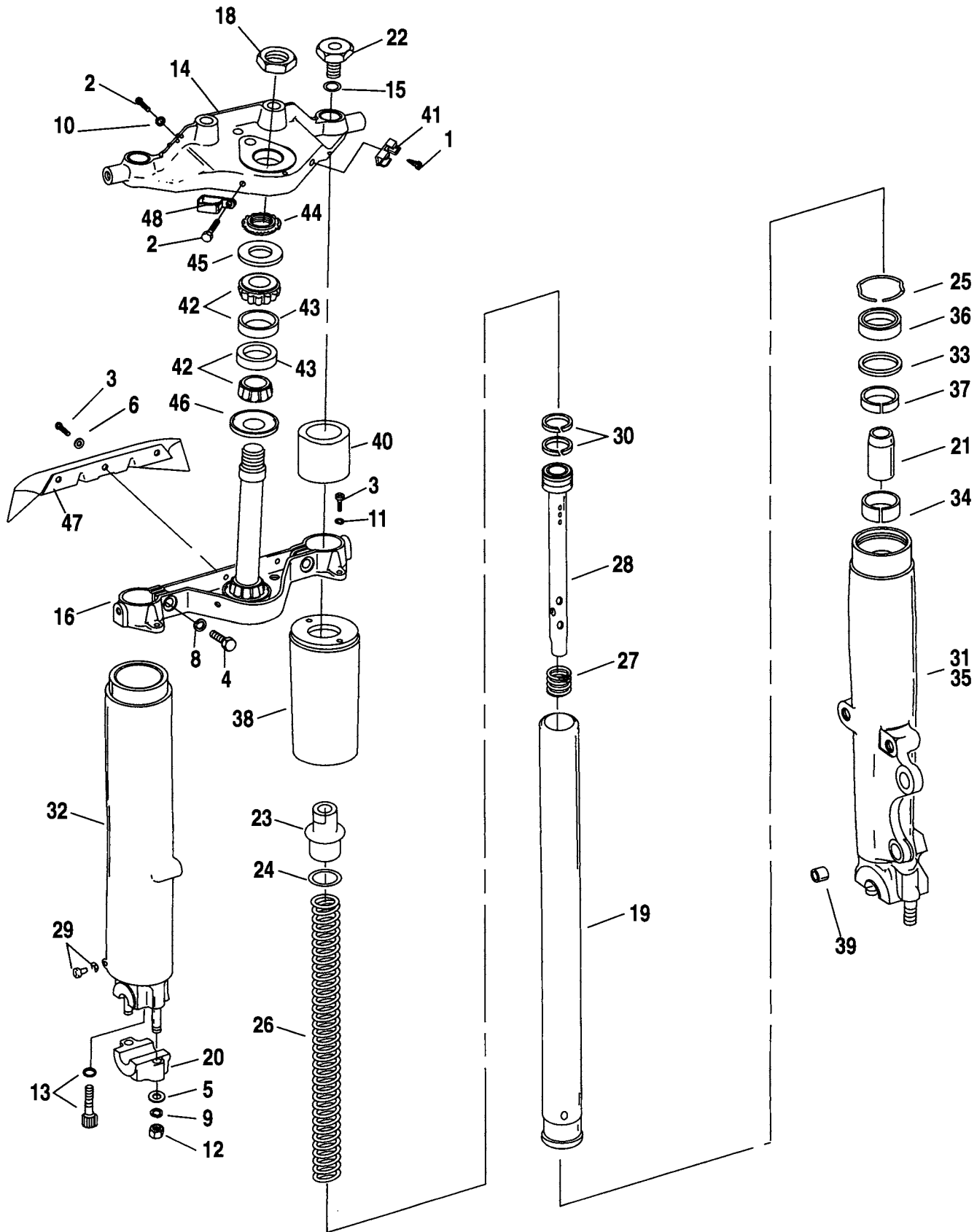

FRONT FORK - FLT MODELS

FB25-1

INDEX NO.	PART NO.	DESCRIPTION	FLT MODELS	FXR MODELS	SOFTAIL MODELS	DYNA MODELS
1	1046	SCREW (2)	93-ALL	--	--	--
	2523	SCREW, handlebar ground	94*-ALL	--	--	--
2	4091	SCREW	93-ALL	--	--	--
	4124	SCREW	94*-ALL	--	--	--
3	3739	BOLT (6)	93*-ALL	--	--	--
4	4729	BOLT (2)	93*-ALL	--	--	--
5	6702	WASHER (2)	93*-ALL	--	--	--
6	6703	WASHER (2)	93*-ALL	--	--	--
8	7039	LOCKWASHER (2)	93*-ALL	--	--	--
9	7041	LOCKWASHER (2)	93*-ALL	--	--	--
10	7069	LOCKWASHER (2)	93-ALL	--	--	--
11	7124	LOCKWASHER (4)	93*-ALL	--	--	--
12	7748W	NUT (2)	93*-ALL	--	--	--
13	45405-75A	SCREW w/ washer, damper tube (2)	93*-ALL	--	--	--
14	45435-93	BRACKET	93*-ALL	--	--	--
15	45443-86	O-RING (2)	93*-ALL	--	--	--
16	45446-87	FORK STEM & BRACKET	93-DJ/P, FA; 94*-DJ/P.FD	--	--	--
	45534-87	FORK STEM & BRACKET	93*-DM	--	--	--
18	45718-60	NUT, fork stem	93*-ALL	--	--	--
19	45827-84	SLIDER TUBE (2)	93*-ALL	--	--	--
20	45832-77A	AXLE CAP, right slider	93*-ALL	--	--	--
21	45834-77	LOWER STOP (2)	93*-ALL	--	--	--
22	45839-84	CAP, upper bracket (2)	93*-ALL	--	--	--
23	45841-84	PLUG, fork tube (2)	93*-ALL	--	--	--
24	45845-77	O-RING, slider tube plug (2)	93*-ALL	--	--	--
25	45847-84	RETAINING RING, oil seal (2)	93*-ALL	--	--	--
26	45853-83	SPRING (2)	93*-ALL	--	--	--
27	45855-77	SPRING, slider tube (2)	93*-ALL	--	--	--
28	45857-83	DAMPER TUBE (2)	93*-ALL	--	--	--

FLT MODELS

FLHTC DJ
 FLTC-U DM
 FLHTC-U DP
 FLHS FA
 FLHR FD

FXR MODELS

FXR EA
 FXRS-SP EG
 FXLR EL
 FXRS-CON EM

SOFTAIL MODELS

FLSTC BJ
 FXSTC BK
 FXSTS BL
 FLSTF BM
 FLSTN BN

DYNA MODELS

FXDL GD
 FXDWG GE
 FXDS-CON GG

FRONT FORK - FLT

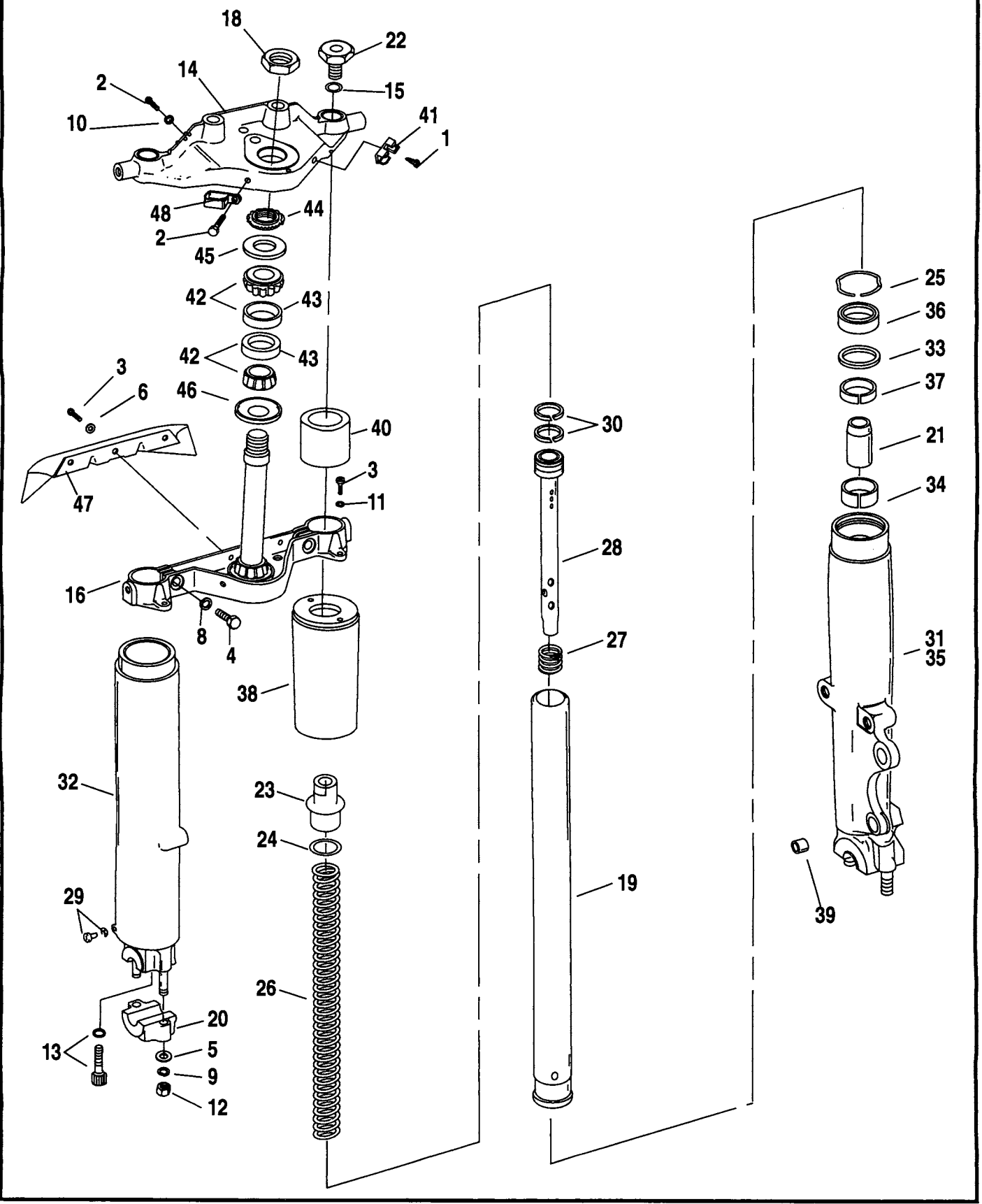

INDEX NO.	PART NO.	DESCRIPTION	FLT MODELS	FXR MODELS	SOFTAIL MODELS	DYNA MODELS
29	45858-77	DRAIN SCREW, damper tube (2)	93*-ALL	--	--	--
30	45859-77	RING, damper tube (4)	93*-ALL	--	--	--
31	45860-84	SLIDER ASSEMBLY, left	93*-ALL	--	--	--
32	45863-84	FORK SLIDER, right (polished)	93*-ALL	--	--	--
	45864-84	FORK SLIDER, left (polished)	93*-ALL	--	--	--
33	45865-84	SPACER, slider (2)	93*-ALL	--	--	--
34	45866-84	BUSHING, slider (2)	93*-ALL	--	--	--
35	45870-84	SLIDER ASSEMBLY, right	93*-ALL	--	--	--
36	45875-84	OIL SEAL (2)	93*-ALL	--	--	--
37	45940-84	BUSHING, slider (2)	93*-ALL	--	--	--
38	45964-86	COVER, slider (stainless steel) (2)	93*-ALL	--	--	--
39	46020-84	BUSHING, brake caliper (2)	93*-ALL	--	--	--
40	47530-79A	FORK STOP (rubber) (2)	93*-ALL	--	--	--
41	47712-91	TERMINAL CONNECTOR (spade)	93-ALL	--	--	--
42	48300-60	ROLLER BEARING, w/ cup	93*-ALL	--	--	--
43	48315-60	CUP, bearing	93*-ALL	--	--	--
44	48333-80	BEARING ADJUSTER	93*-ALL	--	--	--
45	48361-80	DUST SHIELD, bearing - upper	93*-ALL	--	--	--
46	48365-48A	DUST SHIELD, bearing - lower	93*-ALL	--	--	--
47	58520-79A	BAFFLE	93*-ALL	--	--	--
48	68750-93	CLAMP	93*-ALL	--	--	--
		H-D INTERNATIONAL ONLY				
	48140-84A	STEERING HEAD LOCK ASM. (HDI only)	93*-ALL	--	--	--

FLT MODELS

FLHTC
FLTC-U
FLHTC-U
FLHS
FLHR

DJ
DM
DP
FA
FD

FXR MODELS

FXR
FXRS-SP
FXLR
FXRS-CON

EA
EG
EL
EM

SOFTAIL MODELS

FLSTC
FXSTC
FXSTS
FLSTF
FLSTN

BJ
BK
BL
BM
BN

DYNA MODELS

FXDL
FXDWG
FXDS-CON

GD
GE
GG

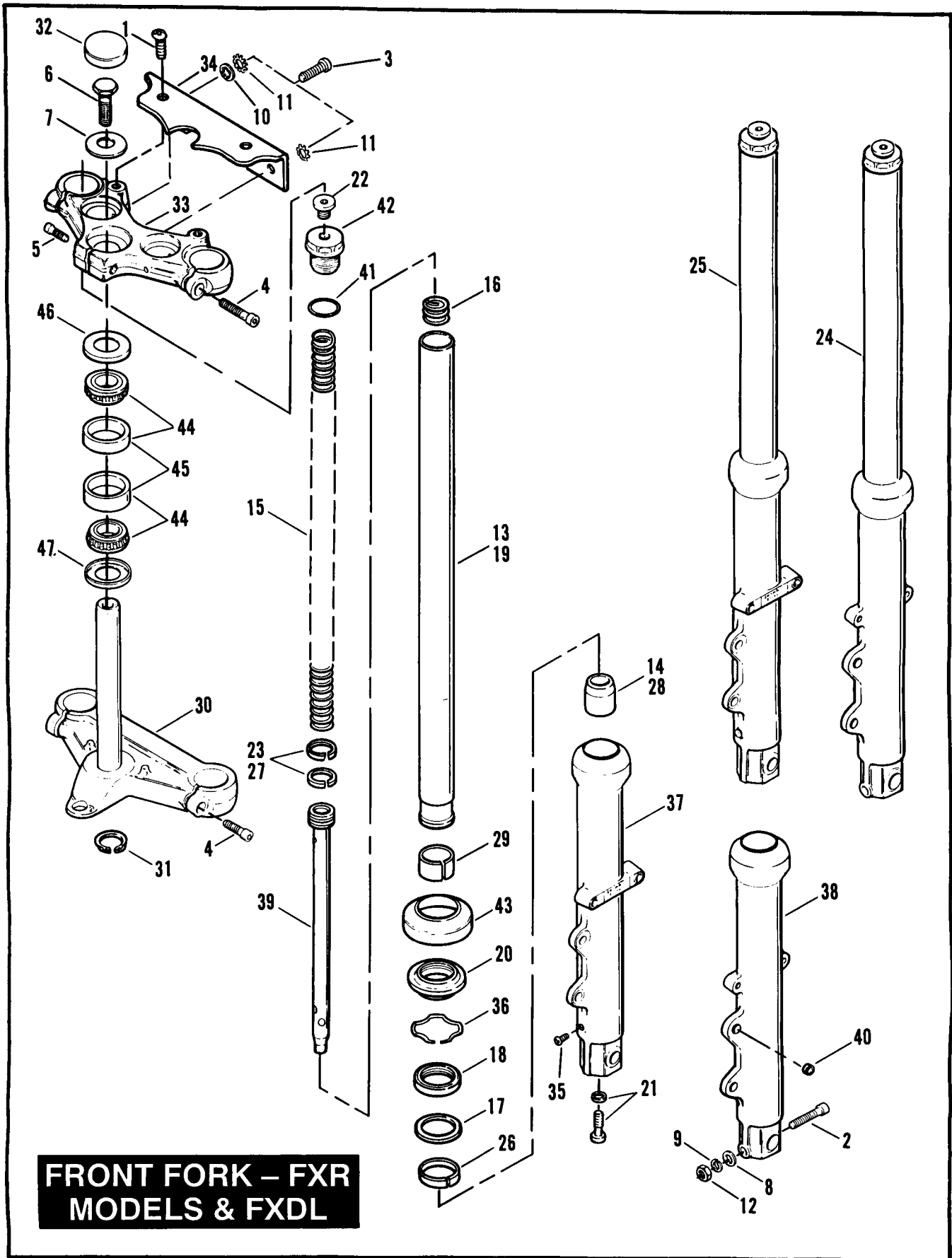

INDEX NO.	PART NO.	DESCRIPTION	FLT MODELS	FXR MODELS	SOFTAIL MODELS	DYNA MODELS
1	2582	SCREW	--	93*-EL	--	--
2	4029A	SCREW	--	93*-ALL	--	93*-GD
3	4091	SCREW	--	93*-ALL	--	--
	4104	SCREW (2)	--	93*-ALL	--	94*-GG
4	4351	SCREW (4-GD;2-GG)	--	93*-ALL	--	93*-GD/G
	4047	SCREW (2)	--	--	--	94*-GG
5	4352	BOLT	--	93*-ALL	--	93*-GD/G
6	4453	SCREW	--	93*-EG/L/M	--	93*-GD/G
	4460	SCREW	--	93*-EA	--	--
7	6655	WASHER	--	93*-ALL	--	93*-GD/G
8	6701	WASHER	--	93*-ALL	--	93*-GD/G
9	7038	LOCKWASHER	--	93*-ALL	--	93*-GD/G
10	7129	LOCKWASHER	--	93*-EA/G/M	--	--
11	7220	LOCKWASHER (2 - FXR)	--	93*-ALL	--	93*-GD/G
12	7783	NUT	--	93*-ALL	--	93*-GD/G
13	45360-90	SLIDER TUBE (2)	--	--	--	93*-GD
	45364-94	SLIDER TUBE (2)	--	--	--	94*-GG
14	45361-90	LOWER STOP (2)	--	--	--	93*-GD/G
15	45362-90	SPRING (2)	--	--	--	93*-GD
	45363-94	SPRING (2)	--	--	--	94*-GG
	45373-88	SPRING (2)	--	93*-EG/M	--	--
	45376-87	SPRING (2)	--	93*-EA/L	--	--
16	45374-87	SPRING, slider (2)	--	93*-ALL	--	93*-GD/G
17	45377-87	SPACER, oil seal (2)	--	93*-ALL	--	93*-GD/G
18	45378-87	OIL SEAL (2)	--	93*-ALL	--	93*-GD/G
19	45381-87	SLIDER TUBE (2)	--	93*-EA/L	--	--
	45393-87	SLIDER TUBE (2)	--	93*-EG/M	--	--
20	45401-87	SEAL, dust (2)	--	93*-ALL	--	93*-GD/G
21	45405-75A	SCREW w/ washer (2)	--	93*-ALL	--	94*-GG
22	45546-90	SCREW w/ washer (2)	--	--	--	93*-GD
23	45460-90	RING, damper tube (2)	--	--	--	93*-GD/G
24	45793-88	FORK SLIDER & TUBE ASSEMBLY, right	--	93*-EG/M	--	--
	45949-92	FORK SLIDER & TUBE ASSEMBLY, right	--	--	--	93*-GD
	45919-87	FORK SLIDER & TUBE ASSEMBLY, right	--	93*-EA/L	--	--
	45976-94	FORK SLIDER & TUBE ASSEMBLY, right	--	--	--	94*-GG
25	45791-88	FORK SLIDER & TUBE ASSEMBLY, left	--	93*-E/GM	--	--
	45920-87	FORK SLIDER & TUBE ASSEMBLY, left	--	93*-EA/L	--	--
	45952-90	FORK SLIDER & TUBE ASSEMBLY, left	--	--	--	93*-GD
	45977-94	FORK SLIDER & TUBE ASSEMBLY, left	--	--	--	94*-GG
26	45461-87	BUSHING, upper (2)	--	93*-ALL	--	93*-GD/G
27	45462-87	RING, damper tube (4)	--	93*-ALL	--	--

FLT MODELS

FLHTC
FLTC-U
FLHTC-U
FLHS
FLHR

DJ
DM
DP
FA
FD

FXR MODELS

FXR
FXRS-SP
FXLR
FXRS-CON
EA
EG
EL
EM

SOFTAIL MODELS

FLSTC
FXSTC
FXSTS
FLSTF
FLSTN
BJ
BK
BL
BM
BN

DYNA MODELS

FXDL
FXDWG
FXDS-CON
GD
GE
GG

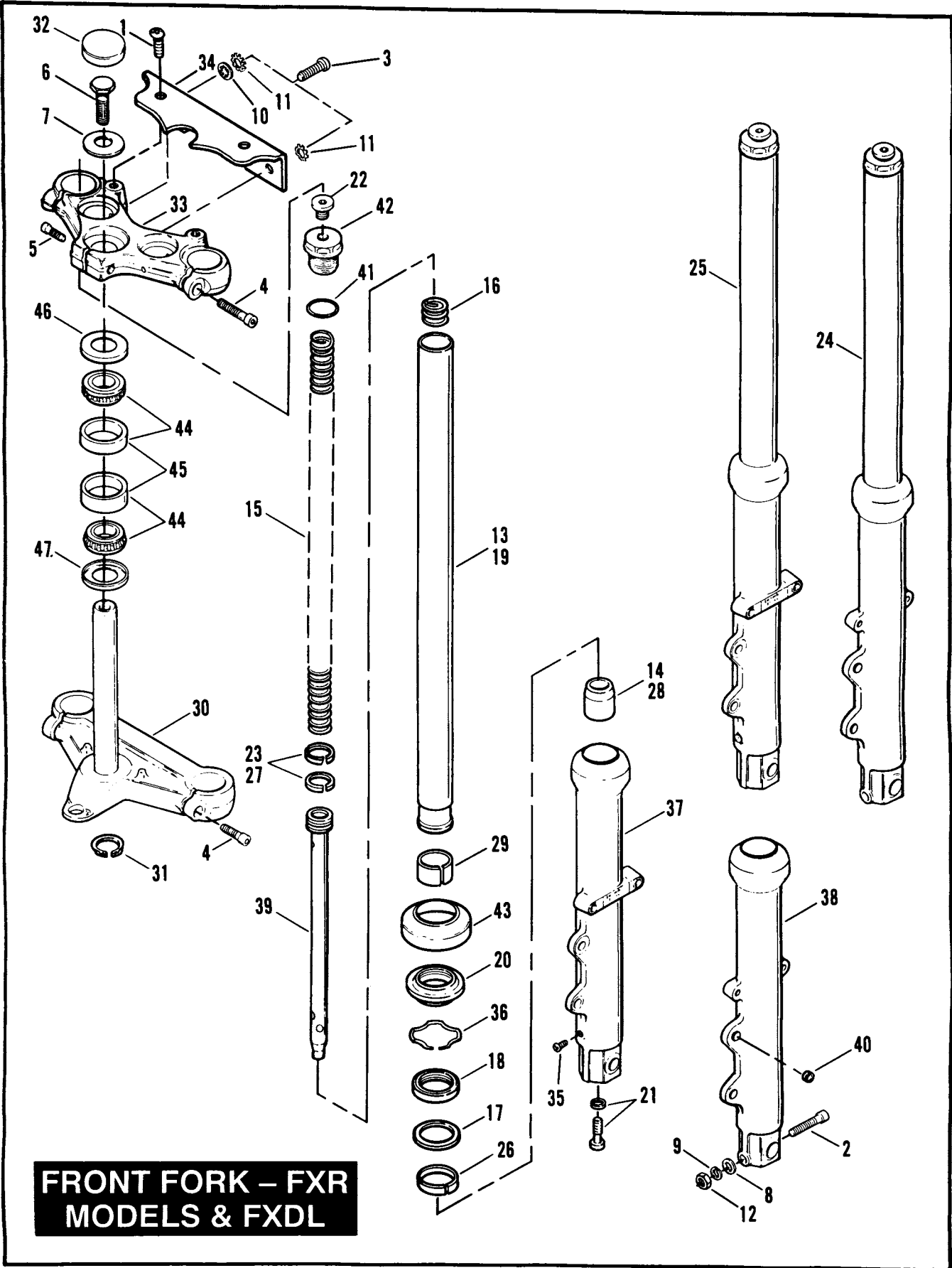

INDEX NO.	PART NO.	DESCRIPTION	FLT MODELS	FXR MODELS	SOFTAIL MODELS	DYNA MODELS
28	45463-87	LOWER STOP (2)	--	93*-ALL	--	--
29	45465-87	BUSHING, slider tube (2)	--	93*-ALL	--	93*-GD/G
30	45561-87	BRACKET, lower w/ stem	--	93*-EG/L/M	--	--
	45563-87	BRACKET, lower w/ stem	--	93*-EA	--	--
	45598-90A	BRACKET, lower w/ stem	--	--	--	93*-GD/G
31	45611-86	RETAINING RING	--	93*-ALL	--	93*-GD/G
32	45668-90	CAP, fork stem	--	93*-EG/L/M	--	93*-GD/G
33	45739-87	BRACKET, upper	--	93*-ALL	--	93*-GD/G
34	45750-87	COVER, upper bracket	--	93*-EL	--	--
35	45790-80	DRAIN SCREW, w/ washer (2)	--	93*-ALL	--	93*-GD/G
36	45905-87	RETAINING RING, oil seal	--	93*-ALL	--	93*-GD/G
37	45921-87	SLIDER ASSEMBLY, left	--	93*-ALL	--	93*-GD/G
38	45922-87	SLIDER ASSEMBLY, right	--	93*-EG/M	--	93*-GD/G
	45923-87	SLIDER ASSEMBLY, right	--	93*-EA/L	--	--
39	45924-87	DAMPER TUBE (2)	--	93*-EA/L	--	--
	45925-88	DAMPER TUBE (2)	--	93*-EG/M	--	--
	45926-90	DAMPER TUBE (2)	--	--	--	93*-GD
	45365-94	DAMPER TUBE (2)	--	--	--	94*-ALL
40	45934-86	BUSHING (2 - EC/G & GD/G)	--	93*-ALL	--	93*-GD/G
41	45984-87	O-RING (2)	--	93*-ALL	--	93*-GD/G
42	45990-88	CAP, slider tube (2)	--	93*-EG/M	--	93*-GD
	45996-87	CAP, slider tube (2)	--	93*-EA/L	--	94*-GG
43	46002-87	COVER, slider (2)	--	93*-ALL	--	93*-GD/G
44	48300-60	ROLLER BEARING, w/ cup (2)	--	93*-ALL	--	93*-GD/G
45	48315-60	BEARING CUP (2)	--	93*-ALL	--	93*-GD/G
46	48361-80	DUST SHIELD, upper	--	93*-ALL	--	93*-GD/G
47	48365-48A	DUST SHIELD, lower	--	93*-ALL	--	93*-GD/G

H-D INTERNATIONAL ONLY

48140-84A	STEERING HEAD LOCK ASM. (HDI only)	--	93*-ALL	--	--
-----------	------------------------------------	----	---------	----	----

FLT MODELS

FLHTC DJ
 FLTC-U DM
 FLHTC-U DP
 FLHS FA
 FLHR FD

FXR MODELS

FXR EA
 FXRS-SP EG
 FXLR EL
 FXRS-CON EM

SOFTAIL MODELS

FLSTC BJ
 FXSTC BK
 FXSTS BL
 FLSTF BM
 FLSTN BN

DYNA MODELS

FXDL GD
 FXDWG GE
 FXDS-CON GG

FRONT FORK - FXSTC & FXDWG

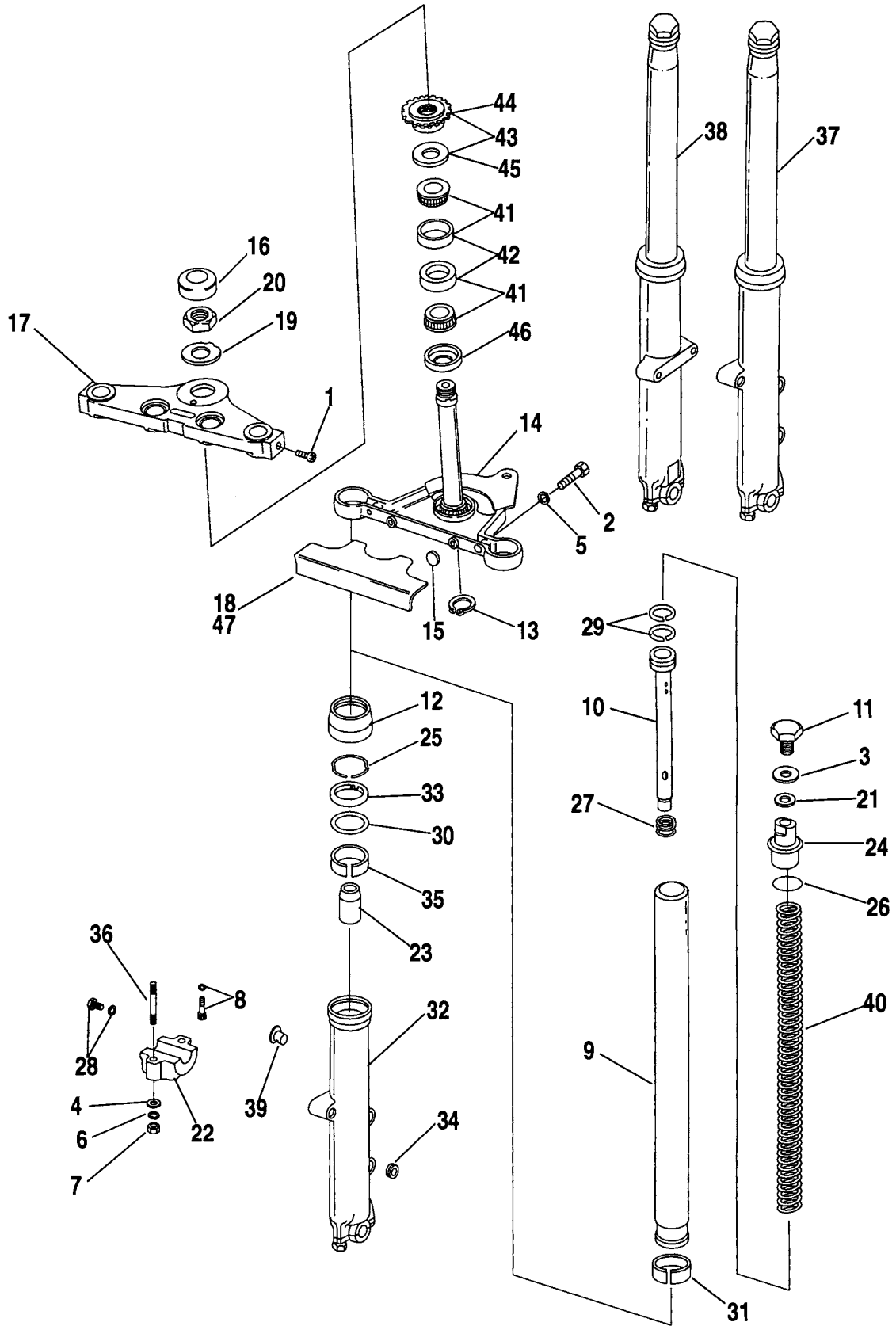

INDEX NO.	PART NO.	DESCRIPTION	FLT MODELS	FXR MODELS	SOFTAIL MODELS	DYNA MODELS
1	2823	SCREW (2)	--	--	93*-BK	93*-GE
2	4729	BOLT (2)	--	--	93*-BK	93*-GE
3	5710	SPACER (2)	--	--	93*-BK	93*-GE
4	6702	WASHER, right slider (2)	--	--	93*-BK	93*-GE
5	7039	LOCKWASHER (2)	--	--	93*-BK	93*-GE
6	7041	LOCKWASHER, right slider (2)	--	--	93*-BK	93*-GE
7	7748W	NUT, right slider (2)	--	--	93*-BK	93*-GE
8	45405-75A	SCREW w/ washer, damper tube (2)	--	--	93*-BK	93*-GE
9	45417-84	SLIDER TUBE (2)	--	--	93*-BK	93*-GE
10	45418-84	DAMPER TUBE, complete (2)	--	--	93*-BK	93*-GE
11	45419-80	CAP, slider tube (2)	--	--	93*-BK	93*-GE
12	45420-80	DUST COVER (2)	--	--	93*-BK	93*-GE
13	45611-86	RETAINING RING	--	--	93*-BK	93*-GE
14	45640-88B	STEM & BRACKET, w/ bearing & shield	--	--	93*-BK	--
	45679-92	STEM & BRACKET, w/ bearing & shield	--	--	--	93*-GE
15	45648-85	PAD (felt) (2)	--	--	93*-BK	93*-GE
16	45670-80	CAP, fork stem	--	--	93*-BK	93*-GE
17	45672-80	BRACKET, upper (chrome)	--	--	93*-BK	93*-GE
18	45685-93	MOUNTING PLATE, headlamp (chrome)	--	--	--	93*-GE
19	45717-63	LOCKWASHER, fork stem nut	--	--	93*-BK	93*-GE
20	45718-60	NUT, fork stem	--	--	93*-BK	93*-GE
21	45733-48	OIL SEAL, fork tube plug (2)	--	--	93*-BK	93*-GE
22	45832-77A	AXLE CAP, right slider	--	--	93*-BK	93*-GE
23	45834-77	LOWER STOP (2)	--	--	93*-BK	93*-GE
24	45838-77	PLUG, fork tube (2)	--	--	93*-BK	93*-GE
25	45842-77	RETAINING RING, oil seal (2)	--	--	93*-BK	93*-GE
26	45845-77	O-RING, slider tube plug (2)	--	--	93*-BK	93*-GE
27	45855-77	SPRING, damper tube (2)	--	--	93*-BK	93*-GE
28	45858-77	DRAIN SCREW w/ washer, slider (2)	--	--	93*-BK	93*-GE
29	45859-77	RING, damper tube (4)	--	--	93*-BK	93*-GE
30	45865-84	WASHER, slider (2)	--	--	93*-BK	93*-GE
31	45866-84	BUSHING, slider tube (2)	--	--	93*-BK	93*-GE
32	45873-91	SLIDER, left	--	--	93*-BK	93*-GE
	45874-91	SLIDER, right	--	--	93*-BK	93*-GE
33	45875-84	OIL SEAL, slider (2)	--	--	93*-BK	93*-GE
34	45934-86	BUSHING, brake caliper	--	--	93*-BK	93*-GE
35	45940-84	BUSHING, slider	--	--	93*-BK	93*-GE
36	45998-73	STUD (2)	--	--	93*-BK	93*-GE
37	46004-91	FORK SLIDER & TUBE ASSEMBLY, left	--	--	93*-BK	93*-GE
38	46006-91	FORK SLIDER & TUBE ASSEMBLY, right	--	--	93*-BK	93*-GE
39	46020-84	BUSHING, upper - left slider - brake caliper	--	--	93*-BK	93*-GE
40	46048-84	SPRING (2)	--	--	93*-BK	93*-GE

FLT MODELS

FLHTC DJ
 FLTC-U DM
 FLHTC-U DP
 FLHS FA
 FLHR FD

FXR MODELS

FXR EA
 FXRS-SP EG
 FXLR EL
 FXRS-CON EM

SOFTAIL MODELS

FLSTC BJ
 FXSTC BK
 FXSTS BL
 FLSTF BM
 FLSTN BN

DYNA MODELS

FXDL GD
 FXDWG GE
 FXDS-CON GG

FRONT FORK - FXSTC & FXDWG

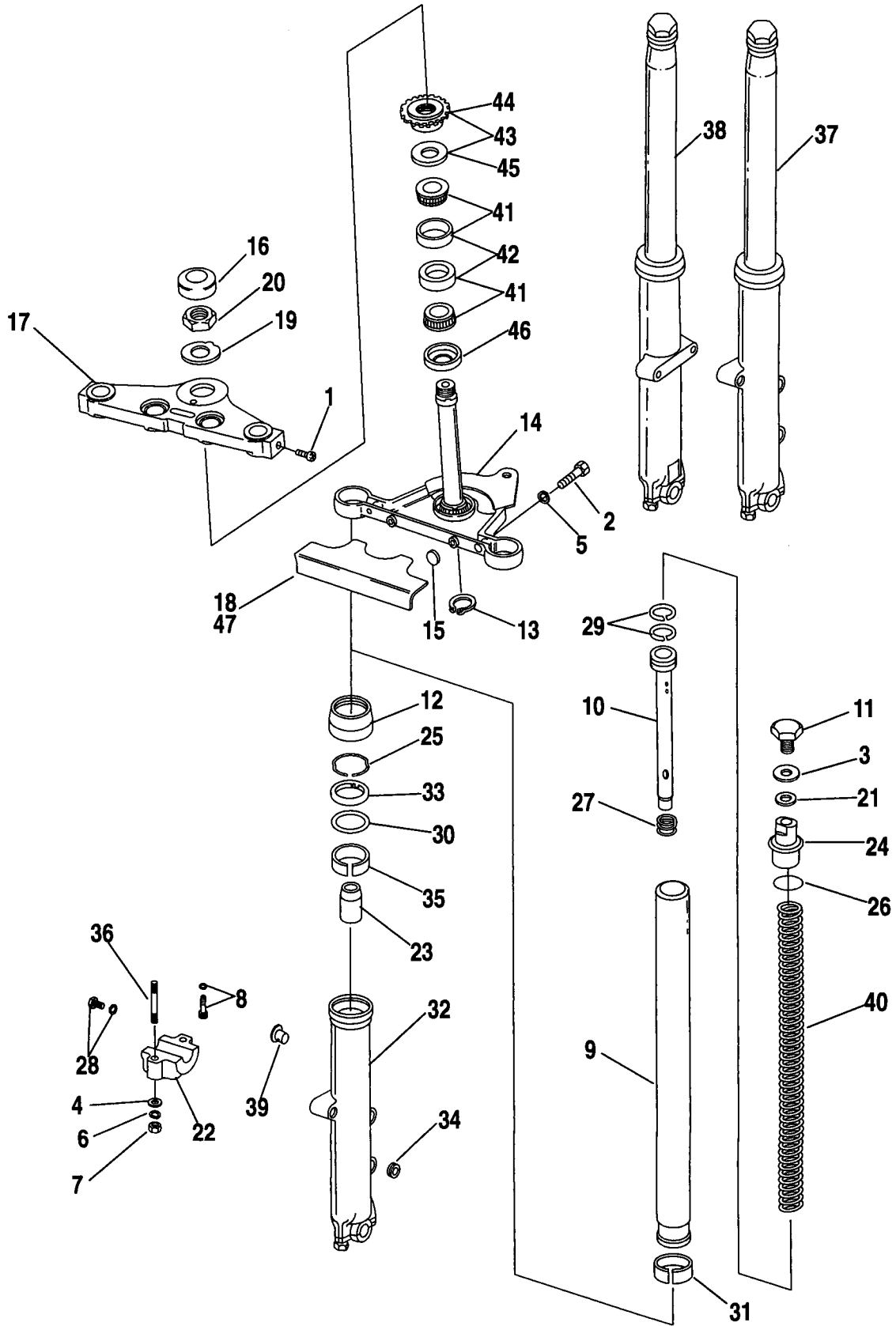

INDEX NO.	PART NO.	DESCRIPTION	FLT MODELS	FXR MODELS	SOFTAIL MODELS	DYNA MODELS
41	48300-60	ROLLER BEARING w/ cup (2)	--	--	93*-BK	--
42	48315-60	BEARING CUP (2)	--	--	93*-BK	--
43	48330-48A	ADJUSTING NUT, upper - w/ shield	--	--	93*-BK	--
44	48332-48B	ADJUSTING NUT, upper	--	--	93*-BK	93*-GE
45	48361-80	DUST SHIELD, bearing - upper	--	--	93*-BK	--
46	48365-48A	DUST SHIELD, bearing - lower	--	--	93*-BK	--
47	67773-80A	MOUNTING PLATE, headlamp (chrome)	--	--	93*-BK	--
		H-D INTERNATIONAL ONLY				
	48140-84A	STEERING HEAD LOCK ASM. (HDI only)	--	--	93*-BK	--

FLT MODELS

FLHTC DJ
 FLTC-U DM
 FLHTC-U DP
 FLHS FA
 FLHR FD

FXR MODELS

FXR EA
 FXRS-SP EG
 FXLR EL
 FXRS-CON EM

SOFTAIL MODELS

FLSTC BJ
 FXSTC BK
 FXSTS BL
 FLSTF BM
 FLSTN BN

DYNA MODELS

FXDL GD
 FXDWG GE
 FXDS-CON GG

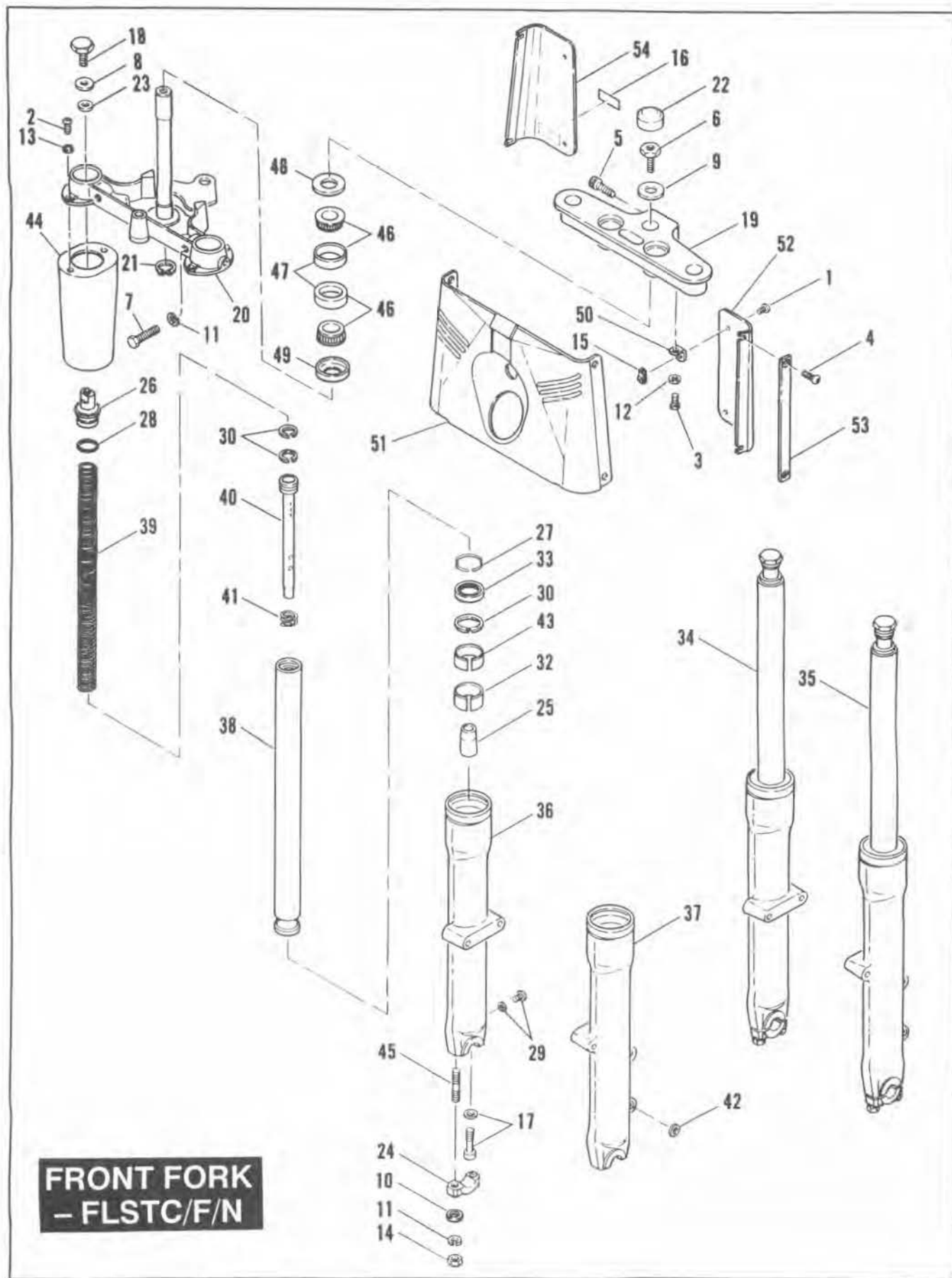

**FRONT FORK
- FLSTC/F/N**

INDEX NO.	PART NO.	DESCRIPTION	FLT MODELS	FXR MODELS	SOFTAIL MODELS	DYNA MODELS
1	923	SCREW (4)	--	--	93*-BJ/M/N	--
2	3739	SCREW (4)	--	--	93*-BJ/M/N	--
3	3953W	BOLT (2)	--	--	93*-BJ/M/N	--
4	4095	SCREW (4)	--	--	93*-BJ/M/N	--
5	4352	SCREW	--	--	93*-BJ/M/N	--
6	4453	BOLT	--	--	93*-BJ/M/N	--
7	4729	BOLT (2)	--	--	93*-BJ/M/N	--
8	5710	SPACER (2)	--	--	93*-BJ/M/N	--
9	6655	WASHER	--	--	93*-BJ/M/N	--
10	6702	WASHER (2)	--	--	93*-BJ/M/N	--
11	7039	LOCKWASHER (2)	--	--	93*-BJ/M/N	--
12	7041	LOCKWASHER (2)	--	--	93*-BJ/M/N	--
13	7124	LOCKWASHER (4)	--	--	93*-BJ/M/N	--
14	7748W	NUT (2)	--	--	93*-BJ/M/N	--
15	8108	CLIP NUT	--	--	93*-BJ/M/N	--
16	14150-86	WARNING LABEL	--	--	93*-BJ/M/N	--
17	45405-75A	SCREW w/ washer (2)	--	--	93*-BJ/M/N	--
18	45419-80	CAP, slider tube (2)	--	--	93*-BJ/M/N	--
19	45456-86	BRACKET, upper	--	--	93*-BJ/M/N	--
20	45605-88	STEM & BRACKET	--	--	93*-BJ/M/N	--
21	45611-86	RETAINING RING, fork stem	--	--	93*-BJ/M/N	--
22	45670-80	CAP, fork stem	--	--	93*-BJ/M/N	--
23	45733-48	OIL SEAL, fork tube plug (2)	--	--	93*-BJ/M/N	--
24	45832-77A	AXLE CAP, right slider	--	--	93*-BJ/M/N	--
25	45834-77	LOWER STOP (2)	--	--	93*-BJ/M/N	--
26	45838-77	PLUG, fork tube (2)	--	--	93*-BJ/M/N	--
27	45842-77	RETAINING RING, oil seal (2)	--	--	93*-BJ/M/N	--
28	45845-77	O-RING, slider tube plug (2)	--	--	93*-BJ/M/N	--
29	45858-77	DRAIN SCREW w/ washer, slider (2)	--	--	93*-BJ/M/N	--
30	45859-77	RING, damper tube (4)	--	--	93*-BJ/M/N	--
31	45865-84	WASHER, slider (2)	--	--	93*-BJ/M/N	--
32	45866-84	BUSHING, slider tube (2)	--	--	93*-BJ/M/N	--
33	45875-84	OIL SEAL (2)	--	--	93*-BJ/M/N	--
34	45915-86	FORK SLIDER & TUBE ASSEMBLY, right	--	--	93*-BJ/M/N	--
35	45916-86	FORK SLIDER & TUBE ASSEMBLY, left	--	--	93*-BJ/M/N	--
36	45917-86	SLIDER, right	--	--	93*-BJ/M/N	--
37	45918-86	SLIDER, left	--	--	93*-BJ/M/N	--
38	45930-86	SLIDER TUBE (2)	--	--	93*-BJ/M/N	--
39	45931-86	SPRING (2)	--	--	93*-BJ/M/N	--
40	45932-86	DAMPER TUBE (2)	--	--	93*-BJ/M/N	--
41	45933-86	SPRING, damper tube (2)	--	--	93*-BJ/M/N	--

FLT MODELS

FLHTC DJ
 FLTC-U DM
 FLHTC-U DP
 FLHS FA
 FLHR FD

FXR MODELS

FXR EA
 FXRS-SP EG
 FXLR EL
 FXRS-CON EM

SOFTAIL MODELS

FLSTC BJ
 FXSTC BK
 FXSTS BL
 FLSTF BM
 FLSTN BN

DYNA MODELS

FXDL GD
 FXDWG GE
 FXDS-CON GG

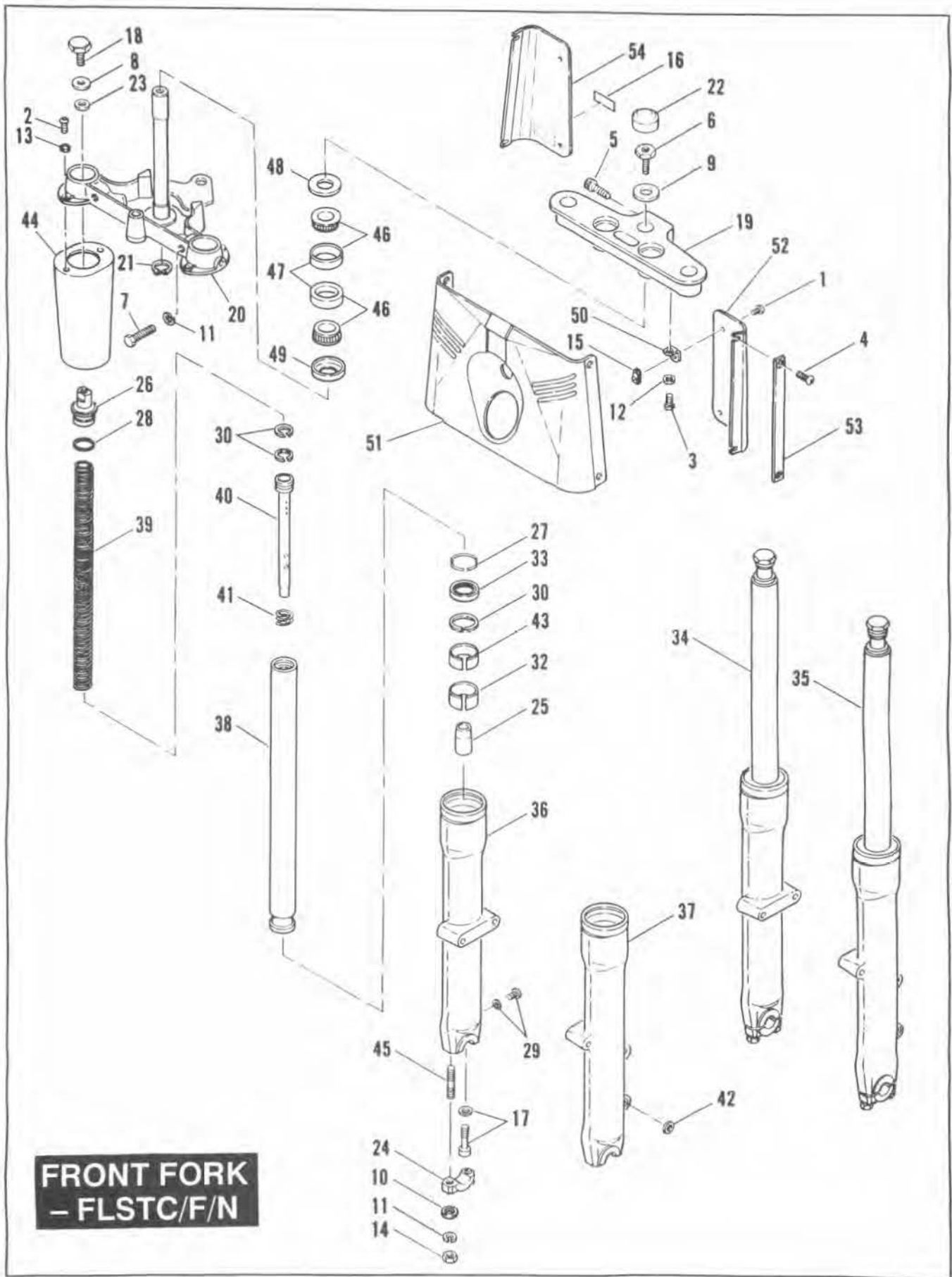

INDEX NO.	PART NO.	DESCRIPTION	FLT MODELS	FXR MODELS	SOFTAIL MODELS	DYNA MODELS
42	45934-86	BUSHING, brake caliper	--	--	93*-BJ/M/N	--
43	45940-84	BUSHING, slider (2)	--	--	93*-BJ/M/N	--
44	45964-86	COVER, slider (2)	--	--	93*-BJ/M/N	--
45	45998-73	STUD (2)	--	--	93*-BJ/M/N	--
46	48300-60	ROLLER BEARING, w/ cup (2)	--	--	93*-BJ/M/N	--
47	48315-60	BEARING CUP (2)	--	--	93*-BJ/M/N	--
48	48361-80	DUST SHIELD, bearing - upper	--	--	93*-BJ/M/N	--
49	48365-48A	DUST SHIELD, bearing - lower	--	--	93*-BJ/M/N	--
50	50991-86	BRACKET, front panel (2)	--	--	93*-BJ/M/N	--
51	67808-86	FRONT PANEL, (buffed stainless steel)	--	--	93*-BJ/M/N	--
52	67816-86	BACK PANEL, left - rear	--	--	93*-BJ/M/N	--
	67821-87	BACK PANEL, left - rear w/ switch hole	--	--	93*-BJ/M/N	--
53	67819-86	TRIM STRIP, front panel (2)	--	--	93*-BJ/M/N	--
54	67820-86	BACK PANEL, right - rear	--	--	93*-BJ/M/N	--
		H-D INTERNATIONAL ONLY				
	48140-84A	STEERING HEAD LOCK ASM. (HDI only)	--	--	93*-BJ/M/N	--

FLT MODELS

FLHTC DJ
 FLTC-U DM
 FLHTC-U DP
 FLHS FA
 FLHR FD

FXR MODELS

FXR EA
 FXRS-SP EG
 FXLR EL
 FXRS-CON EM

SOFTAIL MODELS

FLSTC BJ
 FXSTC BK
 FXSTS BL
 FLSTF BM
 FLSTN BN

DYNA MODELS

FXDL GD
 FXDWG GE
 FXDS-CON GG

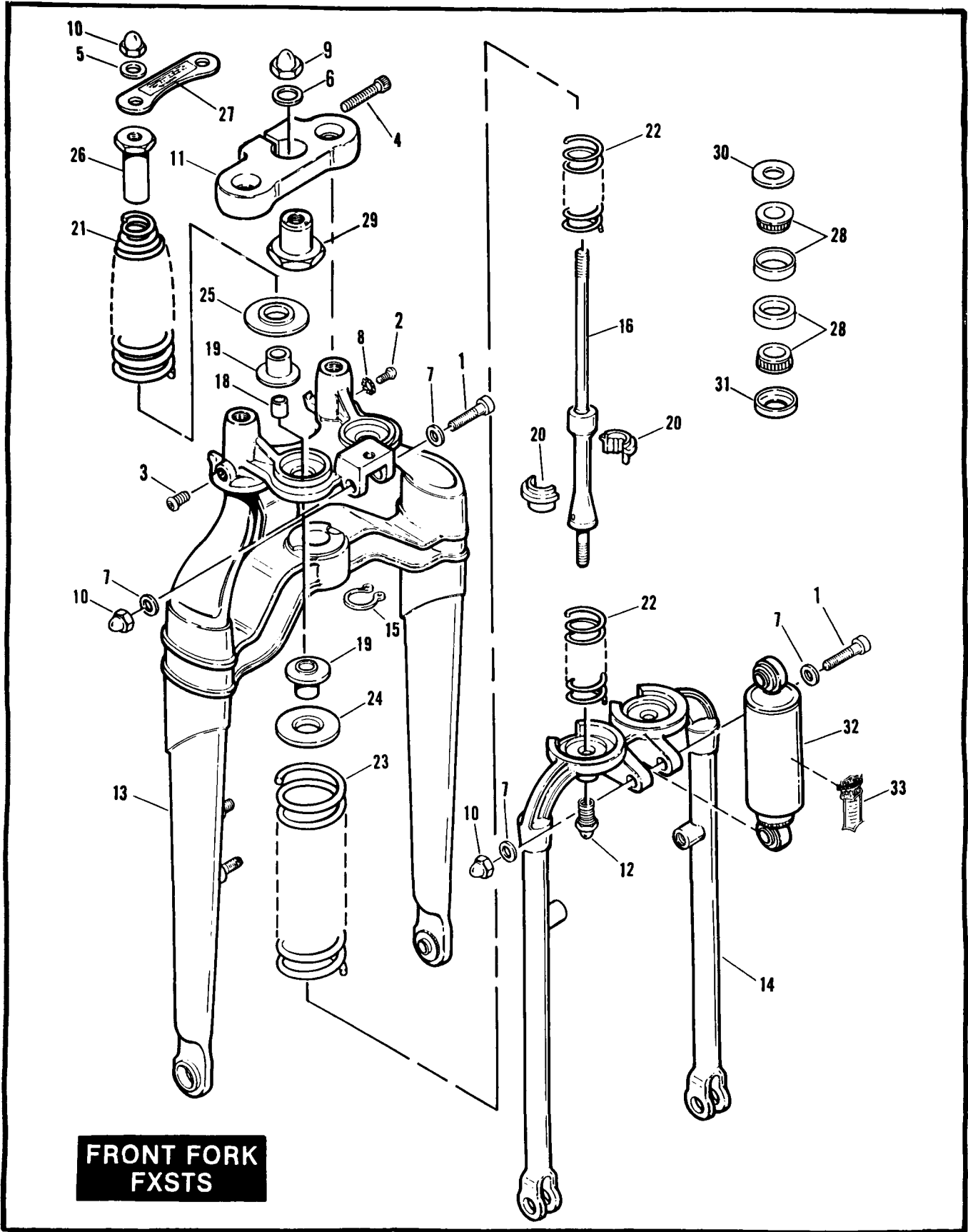

INDEX NO.	PART NO.	DESCRIPTION	FLT MODELS	FXR MODELS	SOFTAIL MODELS	DYNA MODELS
1	855B	SCREW, shock absorber mounting (2)	--	--	93*-BL	--
2	3533	SCREW, spring reaction bracket - right	--	--	93*-BL	--
3	3538	SCREW, spring reaction bracket - left	--	--	93*-BL	--
4	4350A	SCREW, upper triple clamp	--	--	93*-BL	--
5	6353	WASHER, spring rod (2)	--	--	93*-BL	--
6	6756	WASHER, steering stem	--	--	93*-BL	--
7	6812	WASHER, shock absorber mounting (4)	--	--	93*-BL	--
8	7232	LOCKWASHER, spring reaction bracket	--	--	93*-BL	--
9	7627	ACORN NUT, steering stem	--	--	93*-BL	--
10	7680W	ACORN NUT (4)	--	--	93*-BL	--
11	45473-88	UPPER TRIPLE CLAMP	--	--	93*-BL	--
12	45567-88	ACORN NUT, lower spring rod (2)	--	--	93*-BL	--
13	45569-88B	RIGID FORK ASSEMBLY w/ stem	--	--	93*-BL	--
14	45607-93	SPRING FORK	--	--	93*-BL	--
	46008-93	FORK ASSEMBLY, complete	--	--	93*-BL	--
15	45611-86	RETAINING RING, fork stem	--	--	93*-BL	--
16	45628-92	SPRING ROD ASM. (2)	--	--	93*-BL	--
18	45935-88	BUSHING, spring rod (2)	--	--	93*-BL	--
19	45936-88	TRAVEL BUMPER (4)	--	--	93*-BL	--
20	45937-88	SPRING SEAT (4)	--	--	93*-BL	--
21	46053-88	SPRING, rebound - top (2)	--	--	93*-BL	--
22	46054-88	SPRING, compression - inner (4)	--	--	93*-BL	--
23	46055-88	SPRING, compression - outer (2)	--	--	93*-BL	--
24	46056-88	SPRING CUP, compression spring (2)	--	--	93*-BL	--
25	46057-88	SPRING CUP, rebound spring (2)	--	--	93*-BL	--
26	46060-88	SPRING RESTRAINT, upper (2)	--	--	93*-BL	--
27	46065-88	SPRING BRIDGE	--	--	93*-BL	--
28	48300-60	ROLLER BEARING w/ cup	--	--	93*-BL	--
29	48306-88	BEARING RETAINER, steering head	--	--	93*-BL	--
30	48361-80	DUST SHIELD, bearing - upper	--	--	93*-BL	--
31	48365-48A	DUST SHIELD, bearing - lower	--	--	93*-BL	--
32	54483-88	FRONT SHOCK ABSORBER	--	--	93*-BL	--
33	66030-88	DECAL, shock absorber	--	--	93*-BL	--

H-D INTERNATIONAL ONLY

48140-84A	STEERING HEAD LOCK ASM. (HDI only)	--	--	93*-BL	--
-----------	------------------------------------	----	----	--------	----

FLT MODELS

FLHTC DJ
 FLTC-U DM
 FLHTC-U DP
 FLHS FA
 FLHR FD

FXR MODELS

FXR EA
 FXRS-SP EG
 FXLR EL
 FXRS-CON EM

SOFTAIL MODELS

FLSTC BJ
 FXSTC BK
 FXSTS BL
 FLSTF BM
 FLSTN BN

DYNA MODELS

FXDL GD
 FXDWG GE
 FXDS-CON GG

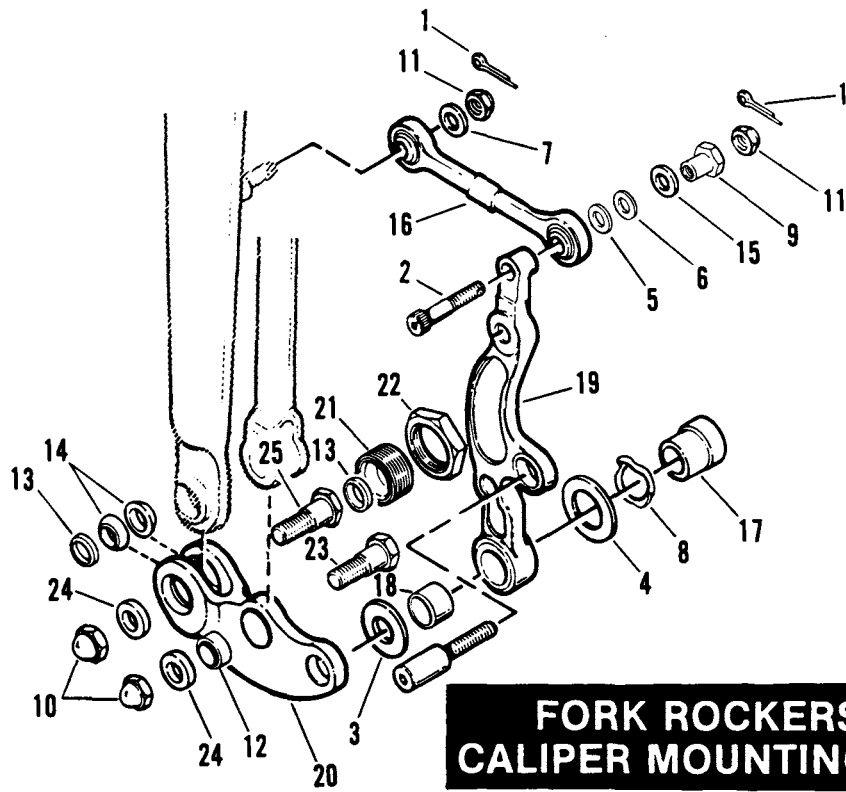

**FORK ROCKERS AND
CALIPER MOUNTING - FXSTS**

INDEX NO.	PART NO.	DESCRIPTION	FLT MODELS	FXR MODELS	SOFTAIL MODELS	DYNA MODELS
1	534	COTTER PIN, brake reaction link (2)	--	--	93*-BL	--
2	4747	SCREW, brake link to bracket	--	--	93*-BL	--
3	6040	WASHER, front axle - outside right	--	--	93*-BL	--
4	6042	WASHER, front axle - inside right	--	--	93*-BL	--
5	6371	WASHER	--	--	93*-BL	--
6	6498	WASHER	--	--	93*-BL	--
7	6812	WASHER, brake reaction link	--	--	93*-BL	--
8	7012	WAVE WASHER, front axle - right	--	--	93*-BL	--
9	7588	NUT, shaft	--	--	93*-BL	--
10	7627	ACORN NUT, rockers to forks (4)	--	--	93*-BL	--
11	7667	LOCKNUT, brake reaction link (2)	--	--	93*-BL	--
12	9139	BEARING, spherical - fork to rocker (2)	--	--	93*-BL	--
13	9140	RACE, spherical bearing - fork to rocker (4)	--	--	93*-BL	--
14	9141	BALL, spherical bearing - fork to rocker (4)	--	--	93*-BL	--
15	11244	SPACER (rubber)	--	--	93*-BL	--
16	41040-88B	BRAKE REACTION LINK	--	--	93*-BL	--
17	44029-88	SPACER, right	--	--	93*-BL	--
18	44030-88	BUSHING, caliper mounting	--	--	93*-BL	--
19	44044-88A	BRACKET, caliper mounting	--	--	93*-BL	--
20	45649-91	ROCKER,, left	--	--	93*-BL	--
	45651-91	ROCKER, right	--	--	93*-BL	--
21	45655-88	BEARING RETAINER, rigid fork (2)	--	--	93*-BL	--
22	45659-88	JAM NUT, bearing retainer (2)	--	--	93*-BL	--
23	45660-88A	PIVOT STUD, spring fork to rocker (2)	--	--	93*-BL	--
24	45662-88	WASHER, rocker to fork leg (4)	--	--	93*-BL	--
25	45663-88A	PIVOT STUD, rigid fork to rocker (2)	--	--	93*-BL	--

FLT MODELS

FLHTC DJ
 FLTC-U DM
 FLHTC-U DP
 FLHS FA
 FLHR FD

FXR MODELS

FXR EA
 FXRS-SP EG
 FXLR EL
 FXRS-CON EM

SOFTAIL MODELS

FLSTC BJ
 FXSTC BK
 FXSTS BL
 FLSTF BM
 FLSTN BN

DYNA MODELS

FXDL GD
 FXDWG GE
 FXDS-CON GG

FRONT FORK AIR CONTROL - FLT

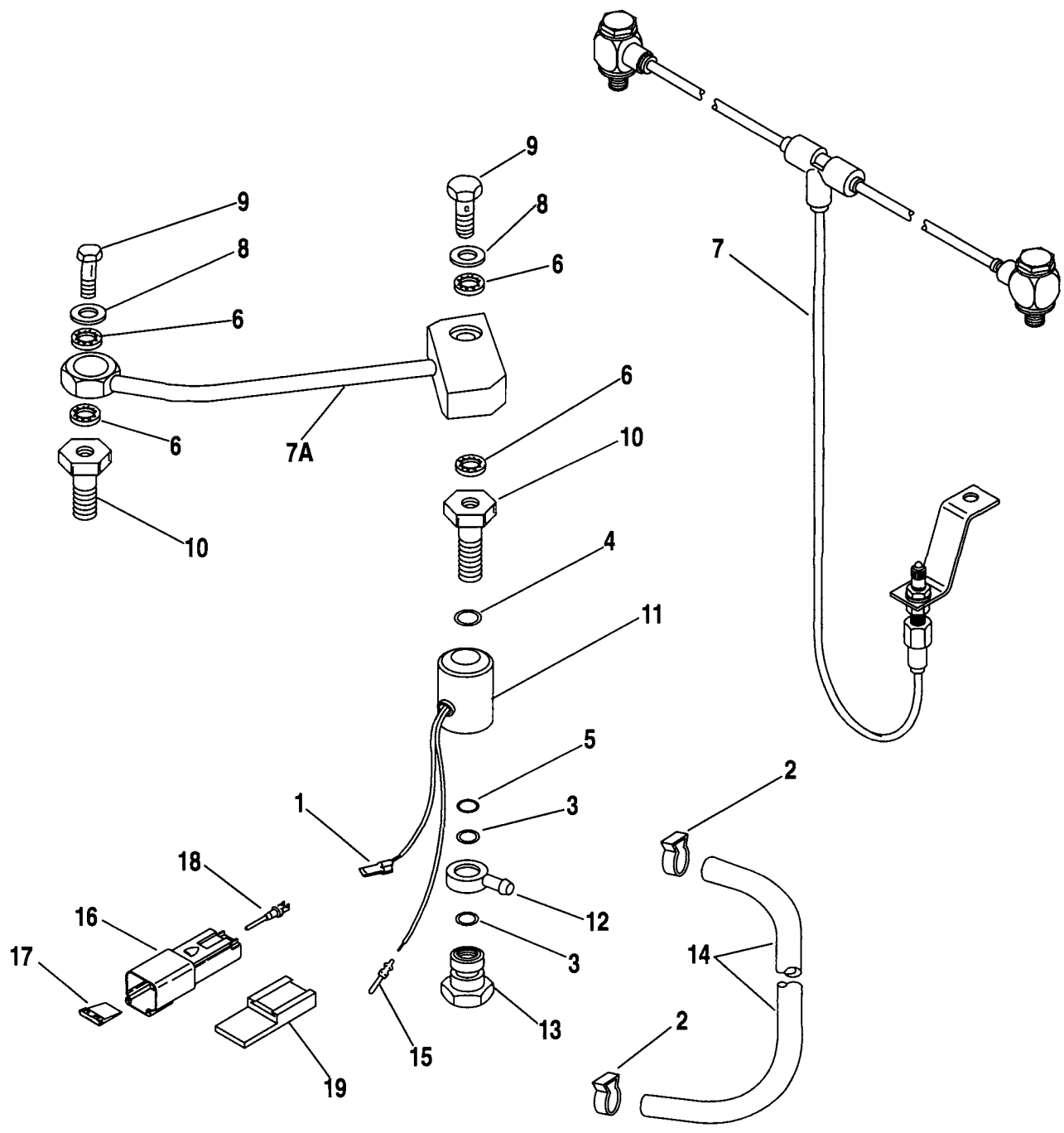

INDEX NO.	PART NO.	DESCRIPTION	FLT MODELS	FXR MODELS	SOFTAIL MODELS	DYNA MODELS
1	9914	TERMINAL, female spade-1/4" slot	93-ALL	--	--	--
2	9946	CLAMP (2)	93-ALL	--	--	--
3	11132	O-RING (2)	94*-DJ/M/P			
4	11170	O-RING	93-ALL	--	--	--
5	11171	O-RING	94*-DJ/M/P			
6	41733-88	GASKET (4)	93-ALL	--	--	--
7	42466-93	MANIFOLD	93*-ALL	--	--	--
7A	42475-94	MANIFOLD ASM.	94*-DJ/M/P			
8	45583-83	GASKET (2)	94*-FD	--	--	--
9	45585-83	BOLT, drilled (2)	93-ALL	--	--	--
10	45839-84	CAP, upper bracket (2)	94*-DJ/M/P			
11	46452-85	VALVE OPERATOR ASSEMBLY	93-ALL	--	--	--
12	46459-86	FITTING, banjo	94*-DJ/M/P			
13	46461-86	BOLT, fitting	93-ALL	--	--	--
14	49059-88A	HOSE	94*-DJ/M/P			
15	72038-71	SOCKET, single pin	93-ALL	--	--	--
16	72102-94BK	RECEPTACLE, two-way pin	94*-DJ/M/P	--	--	--
17	72142-94	PIN LOCK, sec. two-way	94*-DJ/M/P	--	--	--
18	72190-94	TERMINAL, pin (2)	94*-DJ/M/P	--	--	--
19	72199-94	ATTACHMENT CLIP	94*-DJ/M/P	--	--	--

FLT MODELS

FLHTC DJ
 FLTC-U DM
 FLHTC-U DP
 FLHS FA
 FLHR FD

FXR MODELS

FXR EA
 FXRS-SP EG
 FXLR EL
 FXRS-CON EM

SOFTAIL MODELS

FLSTC BJ
 FXSTC BK
 FXSTS BL
 FLSTF BM
 FLSTN BN

DYNA MODELS

FXDL GD
 FXDWG GE
 FXDS-CON GG

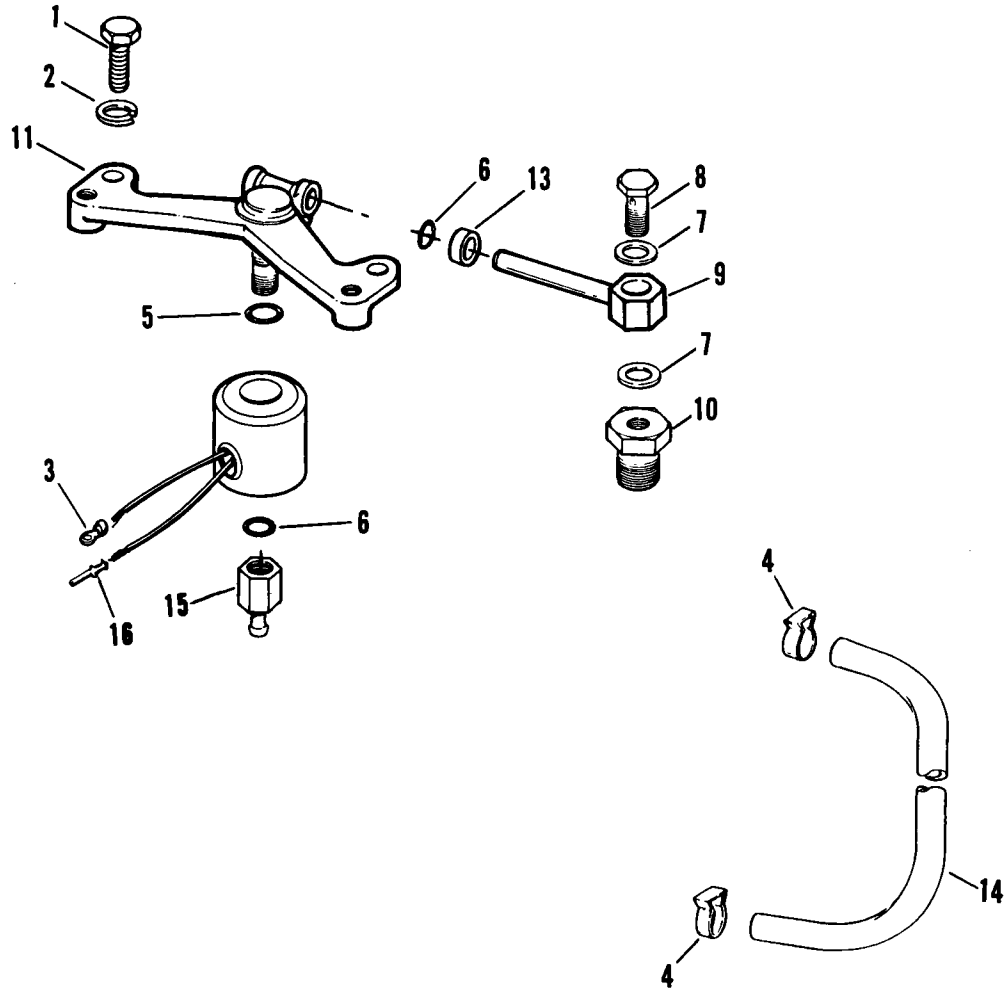

**FRONT FORK AIR CONTROL
- FXRS-SP & FXRS-CON**

INDEX NO.	PART NO.	DESCRIPTION	FLT MODELS	FXR MODELS	SOFTAIL MODELS	DYNA MODELS
1	4017	BOLT (2)	--	93-EG/M	--	--
2	7041	LOCKWASHER (2)	--	93-EG/M	--	--
3	9857	TERMINAL, ring type, No. 10 hole	--	93-EG/M	--	--
4	10080	CLAMP (2)	--	93-EG/M	--	--
5	11170	O-RING	--	93-EG/M	--	--
6	11171	O-RING (3)	--	93-EG/M	--	--
7	45583-83	GASKET (4)	--	93-EG/M	--	--
8	45585-83	BOLT, drilled (2)	--	93-EG/M	--	--
9	45587-88	TUBE (2)	--	93-EG/M	--	--
10	45990-88	CAP, fork slider tube (2)	--	93-EG/M	--	--
11	46451-88A	VALVE BODY	--	93-EG/M	--	--
12	46452-85	VALVE OPERATOR ASSEMBLY	--	93-EG/M	--	--
13	46462-88	SPACER (2)	--	93-EG/M	--	--
14	46463-92	HOSE, anti-dive	--	93-EG/M	--	--
15	46464-92	FITTING	--	93-EG/M	--	--
16	72038-71	SOCKET, single pin	--	93-EG/M	--	--

FLT MODELS

FLHTC DJ
 FLTC-U DM
 FLHTC-U DP
 FLHS FA
 FLHR FD

FXR MODELS

FXR EA
 FXRS-SP EG
 FXLR EL
 FXRS-CON EM

SOFTAIL MODELS

FLSTC BJ
 FXSTC BK
 FXSTS BL
 FLSTF BM
 FLSTN BN

DYNA MODELS

FXDL GD
 FXDWG GE
 FXDS-CON GG

FRAME, REAR FORK & JIFFY STAND - FLT

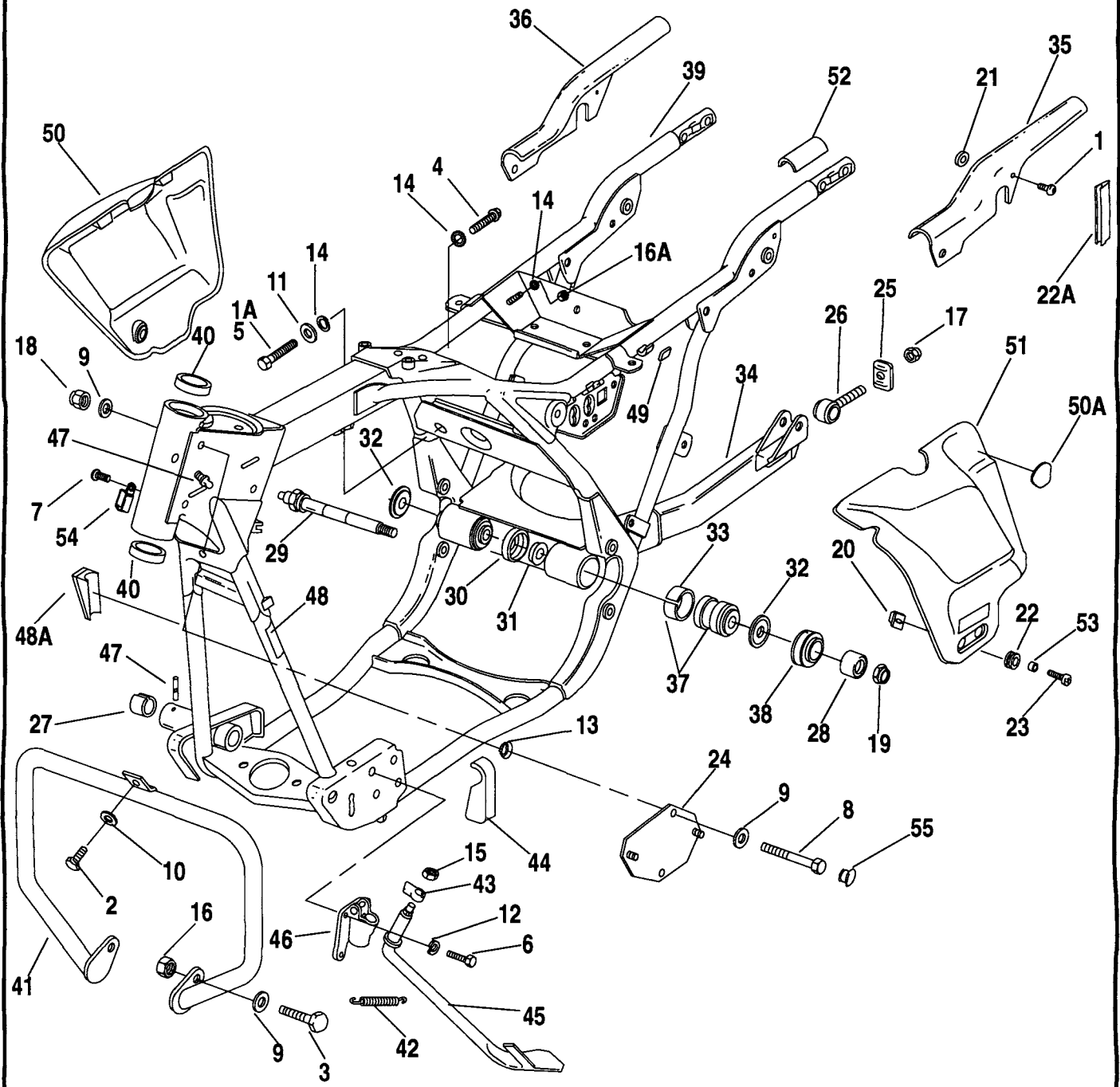

INDEX NO.	PART NO.	DESCRIPTION	FLT MODELS	FXR MODELS	SOFTAIL MODELS	DYNA MODELS
NOTE: REFER TO DEALER ACCESSORY GUIDE FOR PAINTED PART NUMBERS.						
1	932	SCREW (2)	93*-ALL	--	--	--
1A	2551W	SCREW	94*-ALL	--	--	--
2	2708A	SCREW	93*-ALL	--	--	--
3	2879W	BOLT (2)	93*-ALL	--	--	--
5	3787	SCREW	93-ALL	--	--	--
6	3987	BOLT (2)	93*-ALL	--	--	--
7	4091	SCREW	93*-ALL	--	--	--
8	4435W	BOLT (2)	93-ALL	--	--	--
9	6701	WASHER (6-DJ/P; 2-FA/D)	93*-ALL	--	--	--
10	6702	WASHER	93*-ALL	--	--	--
11	6703	WASHER	93-ALL	--	--	--
12	7041	LOCKWASHER (2)	93*-ALL	--	--	--
13	7101	LOCKWASHER	93-ALL	--	--	--
14	7229W	LOCKWASHER (2-1993)	93*-ALL	--	--	--
15	7596	NUT	93*-ALL	--	--	--
16	7601	LOCKNUT (2)	93*-ALL	--	--	--
16A	7686	LOCKNUT, ground	93-ALL	--	--	--
17	7772	LOCKNUT (2)	93*-ALL	--	--	--
18	7775	LOCKNUT (2)	93-ALL	--	--	--
19	7824	LOCKNUT	93*-ALL	--	--	--
20	8102	CLIP NUT (2)	93*-ALL	--	--	--
21	8108	CLIP NUT (2)	93*-ALL	--	--	--
22	11412	GROMMET, side cover (2)	93*-ALL	--	--	--
22A	29274-93	MOLDING (2)	93*-ALL	--	--	--
23	29283-93	SCREW (2)	93*-ALL	--	--	--
24	32451-83	BRACKET, ignition module	93-DJ/P,FA	--	--	--
25	41112-79	END COVER, rear fork (2)	93*-ALL	--	--	--
26	41573-84	ADJUSTER, rear axle (2)	93*-ALL	--	--	--
27	47247-83	BUSHING, foot brake hub (2)	93*-ALL	--	--	--
28	47491-89	CUP WASHER	93*-ALL	--	--	--
29	47492-89A	PIVOT SHAFT KIT w/# 19 & 28	93*-ALL	--	--	--
30	47510-80	RETAINING RING (plastic) (2)	93*-ALL	--	--	--
31	47511-80	SPACER (2)	93*-ALL	--	--	--
32	47513-80	SPACER (nylon) (2)	93*-ALL	--	--	--
33	47538-79	TOLERANCE RING, bushing (2)	93*-ALL	--	--	--

FLT MODELS

FLHTC
FLTC-U
FLHTC-U
FLHS
FLHR

DJ
DM
DP
FA
FD

FXR MODELS

FXR
FXRS-SP
FXLR
FXRS-CON
EA
EG
EL
EM

SOFTAIL MODELS

FLSTC
FXSTC
FXSTS
FLSTF
FLSTN
BJ
BK
BL
BM
BN

DYNA MODELS

FXDL
FXDWG
FXDS-CON
GD
GE
GG

FRAME, REAR FORK & JIFFY STAND - FLT

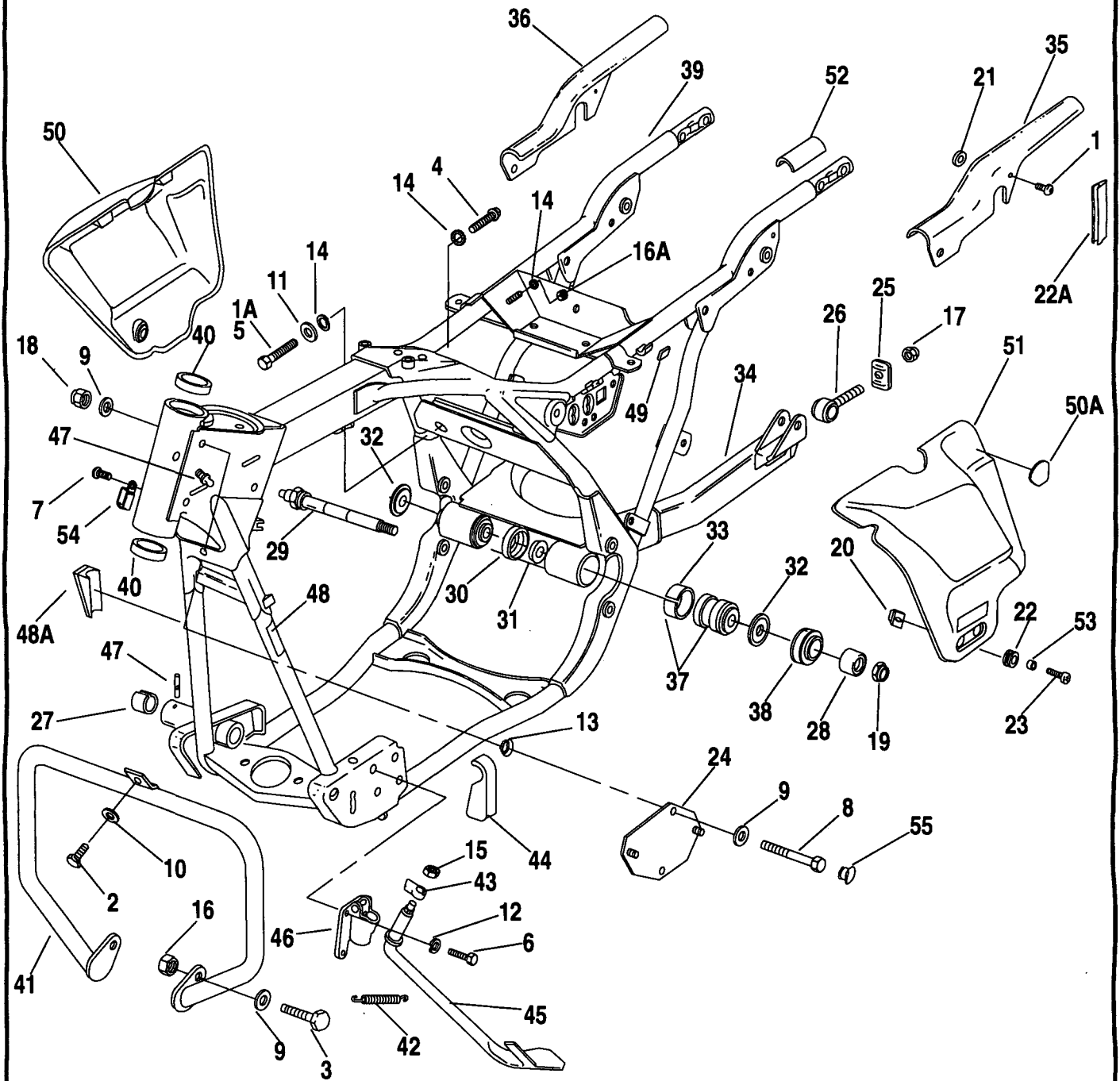

INDEX NO.	PART NO.	DESCRIPTION	FLT MODELS	FXR MODELS	SOFTAIL MODELS	DYNA MODELS
34	47544-85A	REAR FORK	93*-ALL	--	--	--
35	47551-79B	COVER, left w/# 1 & 21	93*-ALL	--	--	--
36	47552-79B	COVER, right w/# 1 & 21	93*-ALL	--	--	--
37	47556-81	BUSHING ASSEMBLY, w/ #33 (2)	93*-ALL	--	--	--
38	47564-86	RUBBER MOUNT (2)	93*-ALL	--	--	--
39	47900-93A	FRAME	93*-ALL	--	--	--
40	48315-60	BEARING CUP (2)	93*-ALL	--	--	--
41	49184-88A	ENGINE GUARD KIT w/ #2	93*-ALL	--	--	--
42	50005-85A	SPRING, jiffy stand	93*-ALL	--	--	--
43	50015-74	LEG STOP	93*-ALL	--	--	--
44	50059-85	BUMPER, jiffy stand	93*-ALL	--	--	--
45	50075-91	LEG, jiffy stand	93*-ALL	--	--	--
46	50078-81	BRACKET, jiffy stand leg	93*-ALL	--	--	--
47	50972-75	FITTING, lubrication (2)	93*-ALL	--	--	--
48	53487-87	PAD, protection	93*-ALL	--	--	--
48A	59258-91	REFLECTOR (amber)(2)	94*-FD	--	--	--
49	66029-80	RUBBER MOUNT, side cover (4)	93*-ALL	--	--	--
50	66046-93	SIDE COVER, right (prime)	93*-ALL	--	--	--
50A	66055-93	WEAR PAD (2)	93*-ALL	--	--	--
51	66248-93	SIDE COVER, left (prime)	93*-ALL	--	--	--
52	66600-84	PAD (2)	93*-ALL	--	--	--
53	67009-72	SPACER (2)	93*-ALL	--	--	--
54	68750-93	CLAMP	93*-ALL	--	--	--
55	90469-94	PLUG (3)	94*-DJ/P;FD	--	--	--
H-D INTERNATIONAL ONLY						
	856A	SCREW (HDI only)	93*-ALL	--	--	--
	3488A	SCREW (HDI only)	93*-ALL	--	--	--
	7748W	NUT (HDI only)	93*-ALL	--	--	--
39	47904-93A	FRAME (HDI only)	93*-ALL	--	--	--
	48140-84	STEERING HEAD LOCK ASM. (HDI only)	93*-ALL	--	--	--
	50050-93	BRACKET, jiffy stand spring (HDI only)	93*-ALL	--	--	--
	50051-93	JIFFY STAND SPRING KIT (HDI only)	93*-ALL	--	--	--

FLT MODELS

FLHTC DJ
 FLTC-U DM
 FLHTC-U DP
 FLHS FA
 FLHR FD

FXR MODELS

FXR EA
 FXRS-SP EG
 FXLR EL
 FXRS-CON EM

SOFTAIL MODELS

FLSTC BJ
 FXSTC BK
 FXSTS BL
 FLSTF BM
 FLSTN BN

DYNA MODELS

FXDL GD
 FXDWG GE
 FXDS-CON GG

FRAME, REAR FORK & JIFFY STAND - FXR

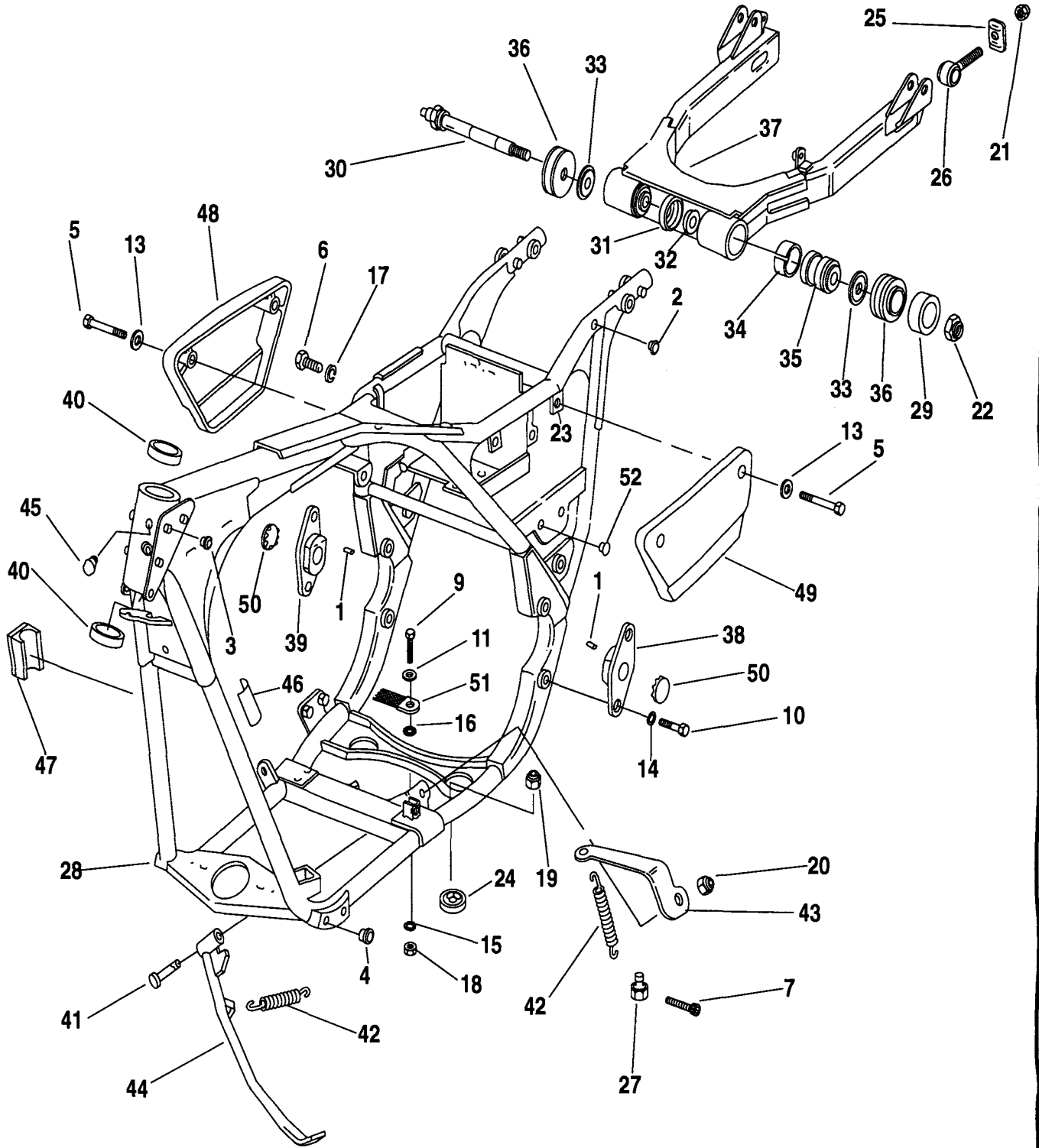

INDEX NO.	PART NO.	DESCRIPTION	FLT MODELS	FXR MODELS	SOFTAIL MODELS	DYNA MODELS
1	604	ROLL PIN (2)	--	93*-ALL	--	--
2	728	PLUG (2)	--	93*-EA/G/L	--	--
3	735	PLUG, fairing mounting holes (4)	--	93*-EA/G/L	--	--
4	740	PLUG	--	93*-EA	--	--
5	813A	SCREW (4)	--	93-ALL	--	--
	3260	SCREW (4)	--	94*-EA/L	--	--
6	2731W	SCREW	--	93*-ALL	--	--
7	3482A	SCREW	--	93*-ALL	--	--
9	3546	BOLT	--	93*-ALL	--	--
10	3782	BOLT (4)	--	93*-ALL	--	--
11	6016	WASHER	--	93*-ALL	--	--
13	6703	WASHER (4)	--	93*-ALL	--	--
14	7039	LOCKWASHER (4)	--	93*-ALL	--	--
15	7041	LOCKWASHER	--	93*-ALL	--	--
16	7100	LOCKWASHER	--	93*-ALL	--	--
17	7118	LOCKWASHER	--	93*-ALL	--	--
18	7731	NUT	--	93*-ALL	--	--
19	7686	LOCKNUT	--	93*-ALL	--	--
20	7716	LOCKNUT	--	93*-ALL	--	--
21	7772	LOCKNUT (2)	--	93*-ALL	--	--
22	7824	LOCKNUT	--	93*-ALL	--	--
23	8099	WELL NUT (4)	--	93-ALL	--	--
24	11472	BUMPER, jiffy stand	--	93*-ALL	--	--
25	41112-79	END COVER, rear fork (2)	--	93*-ALL	--	--
26	41570-77	ADJUSTER, rear fork (2)	--	93*-ALL	--	--
27	46995-91	ANCHOR, spring	--	93*-ALL	--	--

FLT MODELS

FLHTC DJ
 FLTC-U DM
 FLHTC-U DP
 FLHS FA
 FLHR FD

FXR MODELS

FXR EA
 FXRS-SP EG
 FXLR EL
 FXRS-CON EM

SOFTAIL MODELS

FLSTC BJ
 FXSTC BK
 FXSTS BL
 FLSTF BM
 FLSTN BN

DYNA MODELS

FXDL GD
 FXDWG GE
 FXDS-CON GG

FRAME, REAR FORK & JIFFY STAND - FXR

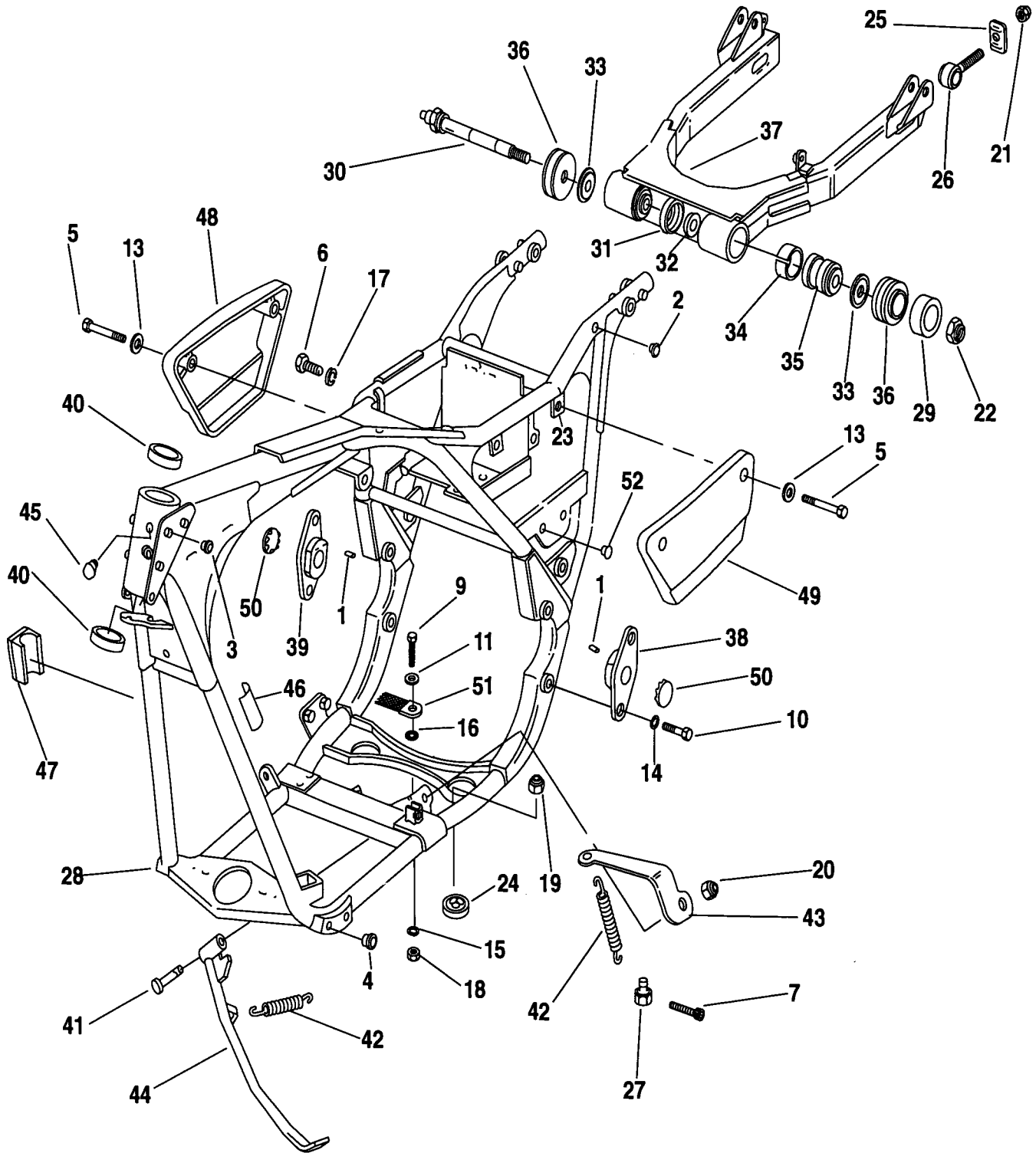

INDEX NO.	PART NO.	DESCRIPTION	FLT MODELS	FXR MODELS	SOFTAIL MODELS	DYNA MODELS
28	47205-91A	FRAME	--	93-ALL	--	--
	47205-94	FRAME	--	94*-ALL	--	--
29	47491-89	CUP WASHER	--	93*-ALL	--	--
30	47492-89A	PIVOT SHAFT KIT,, w/# 20 & 29	--	93*-ALL	--	--
31	47510-80	RETAINING RING (plastic) (2)	--	93*-ALL	--	--
32	47511-80	SPACER (2)	--	93*-ALL	--	--
33	47513-80	WASHER (nylon) (2)	--	93*-ALL	--	--
34	47538-79	TOLERANCE RING, bushing (2)	--	93*-ALL	--	--
35	47556-81	BUSHING ASSEMBLY, w/# 34 (2)	--	93*-ALL	--	--
36	47564-86	MOUNT, rear fork (2)	--	93*-ALL	--	--
37	47820-81A	REAR FORK	--	93*-ALL	--	--
38	47825-81	END CAP, left	--	93*-ALL	--	--
39	47826-81	END CAP, right	--	93*-ALL	--	--
40	48315-60	BEARING CUP (2)	--	93*-ALL	--	--
41	50009-91	PIN	--	93*-ALL	--	--
42	50005-85A	SPRING (2)	--	93*-ALL	--	--
43	50064-91	BRACKET, secondary spring	--	93*-ALL	--	--
44	50031-91	JIFFY STAND	--	93*-EA/L	--	--
	50069-91	JIFFY STAND	--	93*-EG/M	--	--
45	50963-92	PLUG	--	93*-ALL	--	--
46	53487-87	PAD, protective	--	93*-ALL	--	--
47	59272-90	REFLECTOR (amber) (2)	--	93*-ALL	--	--
48	66349-84	SIDE COVER, right	--	93*-ALL	--	--
49	66350-84	SIDE COVER, left	--	93*-ALL	--	--
50	67865-89	PLUG (2)	--	93*-ALL	--	--
51	70186-82	GROUND STRAP	--	93*-ALL	--	--
52	90493-83	PLUG (2)	--	93*-ALL	--	--
H-D INTERNATIONAL ONLY						
28	47206-91A	FRAME (HDI only)	--	93-ALL	--	--
	47206-94	FRAME (HDI only)	--	94*-ALL	--	--
	48140-84A	STEERING HEAD LOCK, (HDI only)	--	93*-ALL	--	--
	50010-84	SPRING, jiffy stand (2) (HDI only)	--	93*-ALL	--	--

FLT MODELS

FLHTC
FLTC-U
FLHTC-U
FLHS
FLHR

DJ
DM
DP
FA
FD

FXR MODELS

FXR
FXRS-SP
FXLR
FXRS-CON

EA
EG
EL
EM

SOFTAIL MODELS

FLSTC
FXSTC
FXSTS
FLSTF
FLSTN

BJ
BK
BL
BM
BN

DYNA MODELS

FXDL
FXDWG
FXDS-CON

GD
GE
GG

FRAME, REAR FORK & JIFFY STAND - SOFTTAIL MODELS

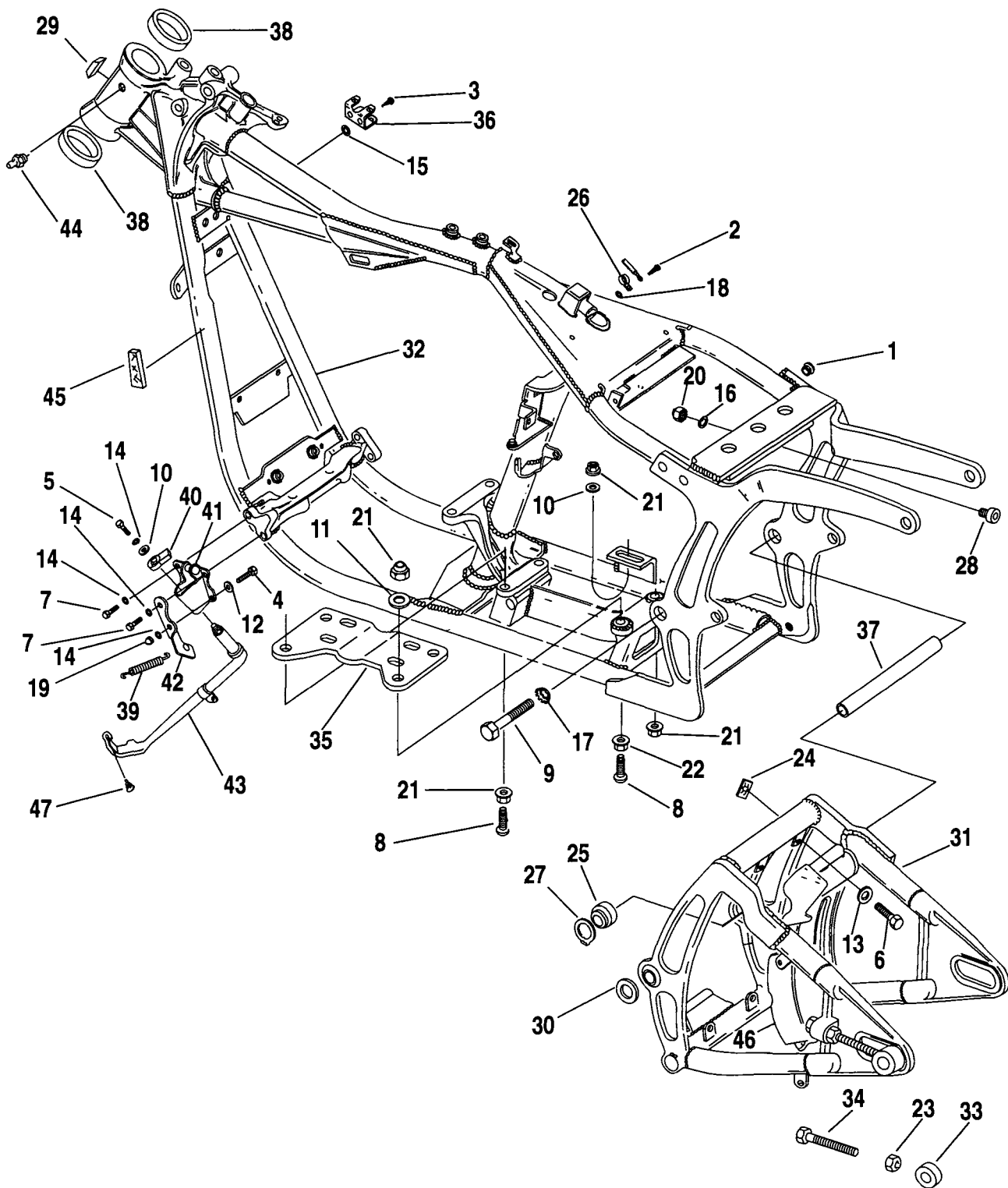

INDEX NO.	PART NO.	DESCRIPTION	FLT MODELS	FXR MODELS	SOFTAIL MODELS	DYNA MODELS
1	728	PLUG, frame side (2)	--	--	93*-BK/L	--
2	939	SCREW	--	--	93*-ALL	--
3	1046	SCREW	--	--	93*-ALL	--
4	2871W	BOLT (2)	--	--	94*-BJ/M/N	--
	3974HW	BOLT (2)	--	--	93-BK/L	--
	3987	BOLT (2)	--	--	94*-BK/L	--
5	4014W	BOLT (2)	--	--	93-BJ/M/N	--
	2882W	BOLT	--	--	93*-ALL	--
6	3787	BOLT (4)	--	--	93*-BJ/M/N	--
7	3991	BOLT (2)	--	--	94*-ALL	--
	3996	BOLT (2)	--	--	93-ALL	--
8	4044	SCREW (4)	--	--	93*-ALL	--
9	4961	BOLT (2)	--	--	93*-ALL	--
10	6474	WASHER	--	--	93*-BK	--
11	6701	WASHER	--	--	93*-ALL	--
12	6702	WASHER	--	--	93*-ALL	--
13	6703	WASHER (4)	--	--	93*-BK/L	--
14	7041	LOCKWASHER (5)	--	--	93*-ALL	--
15	7115	LOCKWASHER	--	--	93*-ALL	--
16	7124	LOCKWASHER	--	--	93*-ALL	--
17	7142	LOCKWASHER (2)	--	--	93*-ALL	--
18	7230	LOCKWASHER	--	--	93*-ALL	--
19	7507	ACORN NUT (3)	--	--	94*-BK/L	--
	7748W	NUT (3)	--	--	94*-BJ/M/N	--
20	7736	ACORN NUT (chrome) (3)	--	--	93-BK/L	--
	7753	NUT, jiffy stand (3)	--	--	93-BJ/M/N	--
	7742	LOCKNUT (2)	--	--	93*-BJ/M/N	--
21	7778	LOCKNUT (4)	--	--	93*-ALL	--
22	7782	FLANGE NUT (5)	--	--	93*-ALL	--
23	7783	NUT, rear axle adj. (2)	--	--	93*-ALL	--
24	8108	SPEED NUT (4)	--	--	93*-ALL	--
25	9076	BEARING, rear fork pivot (2)	--	--	93*-ALL	--
26	10059A	CLAMP	--	--	93*-ALL	--
27	11158	RETAINING RING, fork bearing (2)	--	--	93*-ALL	--
28	11451	CUSHION (2)	--	--	93*-ALL	--
29	11456	BUMPER	--	--	93*-BL	--

FLT MODELS

FLHTC DJ
 FLTC-U DM
 FLHTC-U DP
 FLHS FA
 FLHR FD

FXR MODELS

FXR EA
 FXRS-SP EG
 FXLR EL
 FXRS-CON EM

SOFTAIL MODELS

FLSTC BJ
 FXSTC BK
 FXSTS BL
 FLSTF BM
 FLSTN BN

DYNA MODELS

FXDL GD
 FXDWG GE
 FXDS-CON GG

FRAME, REAR FORK & JIFFY STAND - SOFTTAIL MODELS

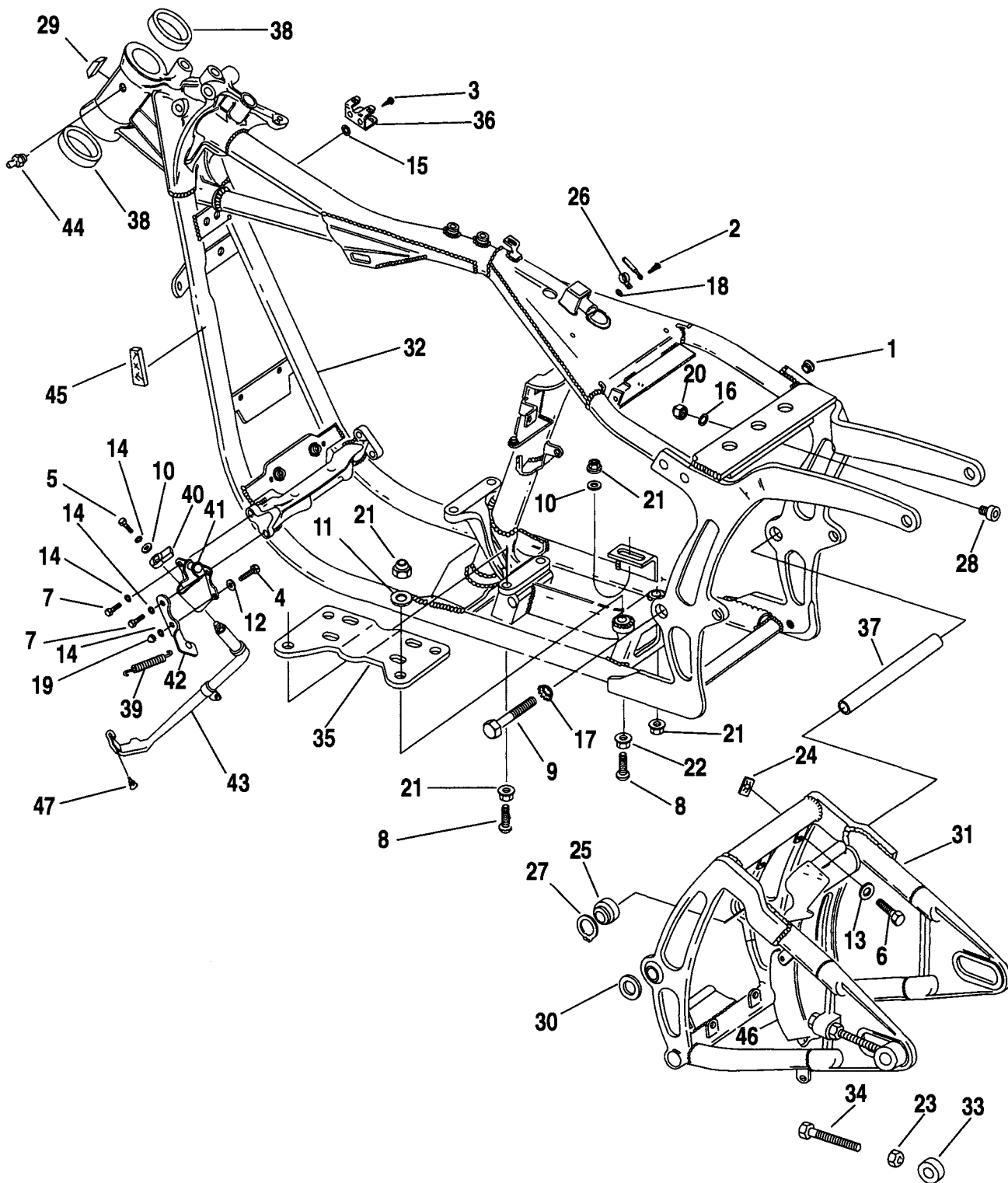

FRAME, REAR FORK & JIFFY STAND - SOFTAIL MODELS

FB27B-2

INDEX NO.	PART NO.	DESCRIPTION	FLT MODELS	FXR MODELS	SOFTAIL MODELS	DYNA MODELS
30	43283-86	SPACER, rear fork pivot (2)	--	--	93*-ALL	--
31	47573-89A	REAR FORK, w/ #25 & 27	--	--	93*-ALL	--
32	47008-92	FRAME	--	--	93*-ALL	--
33	47577-86	SPACER, rear axle adj. (2)	--	--	93*-ALL	--
34	47579-93	ADJUSTING SCREW, rear axle (2)	--	--	93*-ALL	--
35	47698-86B	TRANSMISSION MOUNTING PLATE	--	--	93*-ALL	--
36	47712-91	TAB, electrical	--	--	93*-ALL	--
37	48031-89A	SWING AXIS TUBE	--	--	93*-ALL	--
38	48315-60	BEARING CUP (2)	--	--	93*-ALL	--
39	50005-85A	SPRING, jiffy stand leg	--	--	93*-ALL	--
40	50015-74	LEG STOP	--	--	93*-ALL	--
41	50018-85	LEG BRACKET, (chrome)	--	--	93*-ALL	--
42	50028-91	BRACKET, spring (chrome)	--	--	93*-ALL	--
43	50087-89A	LEG, jiffy stand (chrome)	--	--	93*-ALL	--
44	50972-75	FITTING, lubrication	--	--	93*-ALL	--
45	59258-91	REFLECTOR (amber) (2)	--	--	93*-ALL	--
46	60363-86C	DEBRIS DEFLECTOR	--	--	93*-ALL	--
47	62123-66	BUMPER	--	--	93*-ALL	--
H-D INTERNATIONAL ONLY						
32	48130-92	FRAME, (HDI only)	--	--	93*-ALL	--
	48140-84A	STEERING HEAD LOCK (HDI only)	--	--	93*-ALL	--
	50025-84	SPRING, jiffy stand (HDI only)	--	--	93*-ALL	--
	50027-84	SPRING, jiffy stand (HDI only)	--	--	93*-ALL	--
	50034-84	SPRING, jiffy stand (HDI only)	--	--	93*-ALL	--
45	59265-90	REFLECTOR (amber) (2) (HDI only)	--	--	93*-BL/M	--

FLT MODELS

FLHTC DJ
 FLTC-U DM
 FLHTC-U DP
 FLHS FA
 FLHR FD

FXR MODELS

FXR EA
 FXRS-SP EG
 FXLR EL
 FXRS-CON EM

SOFTAIL MODELS

FLSTC BJ
 FXSTC BK
 FXSTS BL
 FLSTF BM
 FLSTN BN

DYNA MODELS

FXDL GD
 FXDWG GE
 FXDS-CON GG

FRAME, REAR FORK & JIFFY STAND - DYNA MODELS

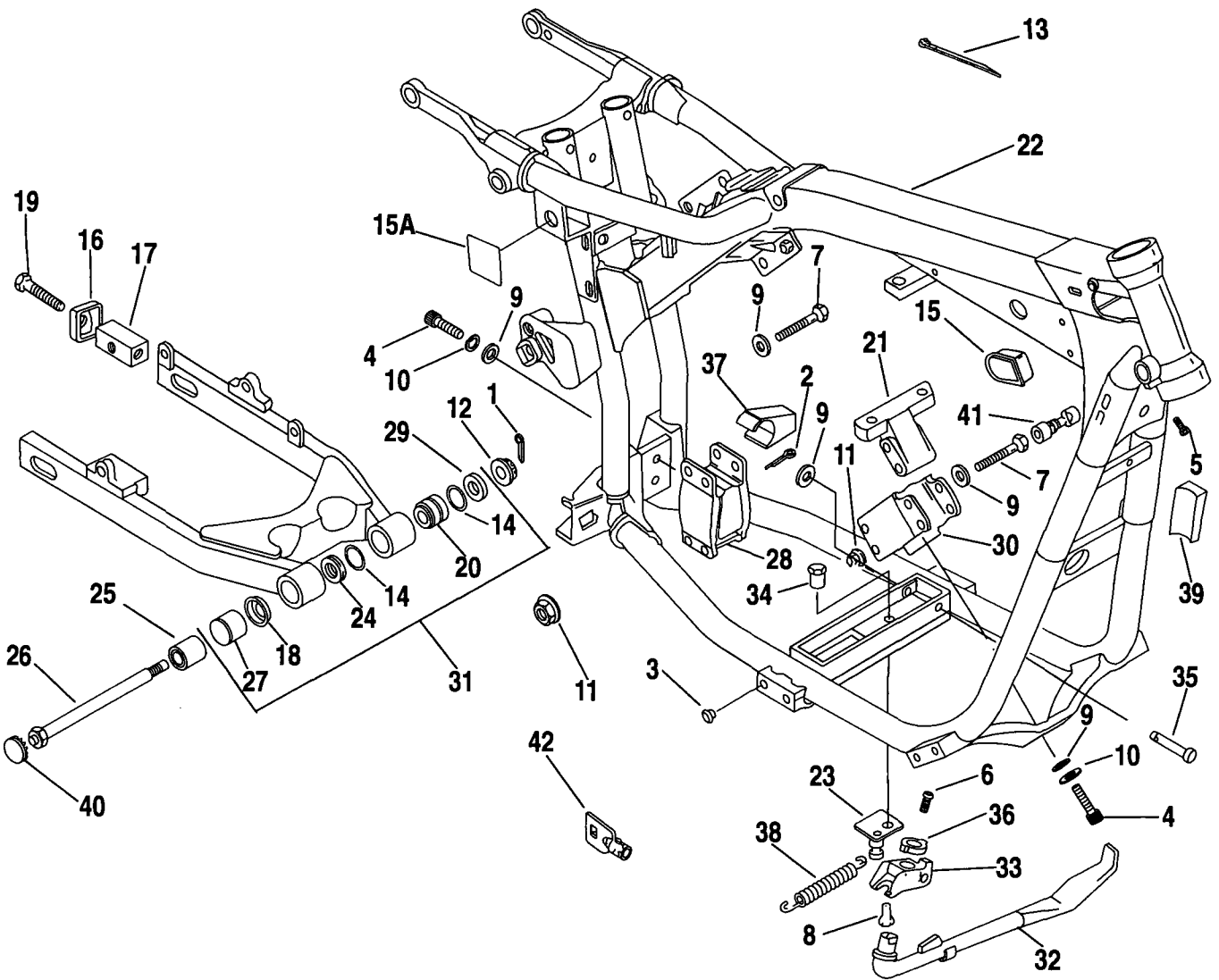

FRAME, REAR FORK & JIFFY STAND - DYNA MODELS

FB27C

INDEX NO.	PART NO.	DESCRIPTION	FLT MODELS	FXR MODELS	SOFTAIL MODELS	DYNA MODELS
1	534	COTTER PIN	--	--	--	93*-ALL
2	554	COTTER PIN	--	--	--	93*-ALL
3	740	PLUG (4)	--	--	--	93*-GD
4	3214	SCREW (4)	--	--	--	93*-ALL
5	3233	SET SCREW (2)	--	--	--	93*-ALL
6	3487	SCREW	--	--	--	93*-ALL
7	3509	SCREW (4)	--	--	--	93*-ALL
8	3655	SCREW	--	--	--	93*-ALL
9	6701	WASHER (9)	--	--	--	93*-ALL
10	7038	LOCKWASHER (4)	--	--	--	93*-ALL
11	7601	LOCKNUT (4)	--	--	--	93*-ALL
12	7734W	NUT, flanged - castle	--	--	--	93*-ALL
13	10039	CABLE STRAP	--	--	--	93*-ALL
14	11139	O-RING (2)	--	--	--	93*-ALL
15	11457	PLUG, steering head	--	--	--	93*-ALL
15A	14273-93	DECAL, hole cover	--	--	--	93*-GE
16	41113-90	PLATE (2)	--	--	--	93*-ALL
17	41571-92	BLOCK (2)	--	--	--	93*-ALL
18	41585-90	DUST SHIELD	--	--	--	93*-ALL
19	45991-92	SCREW (2)	--	--	--	93*-ALL
20	47082-81	BEARING	--	--	--	99*-ALL
21	47226-90A	BRACKET KIT, front engine mount	--	--	--	93*-ALL
22	47427-92A	FRAME	--	--	--	93*-GD/E
	47456-94	FRAME	--	--	--	94*-GG
23	47303-91	ANCHOR	--	--	--	93*-ALL
24	47496-90	SPACER, left	--	--	--	93*-ALL
25	47499-90	SPACER, right	--	--	--	93*-ALL
26	47515-90A	PIVOT BOLT	--	--	--	93*-ALL
27	47541-90	BUSHING	--	--	--	93*-ALL
28	47564-90B	ISOLATOR, rear	--	--	--	93*-ALL
29	47565-90	WASHER	--	--	--	93*-ALL
30	47583-90B	ISOLATOR, front	--	--	--	93*-ALL
31	47820-90A	REAR FORK w/bearings	--	--	--	93*-ALL
32	49704-90	LEG, jiffy stand	--	--	--	93*-GD/E
33	49720-90	PIVOT BLOCK	--	--	--	93*-ALL
34	49723-90	THREADED SPACER	--	--	--	93*-ALL
35	50003-89A	PIN	--	--	--	93*-ALL
36	50053-90	CATCH	--	--	--	93*-ALL
37	50054-90	BUMPER	--	--	--	93*-GD/E
	62123-66	BUMPER	--	--	--	94*-GG
38	50057-91	SPRING	--	--	--	93*-ALL
39	59272-90	REFLECTOR (amber) (2)	--	--	--	93*-ALL
40	67859-90	PLUG (chrome)	--	--	--	93*-ALL
41	71419-93	LOCKSET, fork & ignition w/key (not illustrated)	--	--	--	93*-GE
	71421-90	LOCKSET, fork & ignition w/key (not illustrated)	--	--	--	93-GD/G
	71421-94	LOCKSET, fork & ignition w/key (not illustrated)	--	--	--	94*-GD
42	71452-91A	KEY (specify code no.)	--	--	--	93*-ALL

FLT MODELS

FLHTC DJ
 FLTC-U DM
 FLHTC-U DP
 FLHS FA
 FLHR FD

FXR MODELS

FXR EA
 FXRS-SP EG
 FXLR EL
 FXRS-CON EM

SOFTAIL MODELS

FLSTC BJ
 FXSTC BK
 FXSTS BL
 FLSTF BM
 FLSTN BN

DYNA MODELS

FXDL GD
 FXDWG GE
 FXDS-CON GG

SEATS & LUGGAGE RACK - FLT

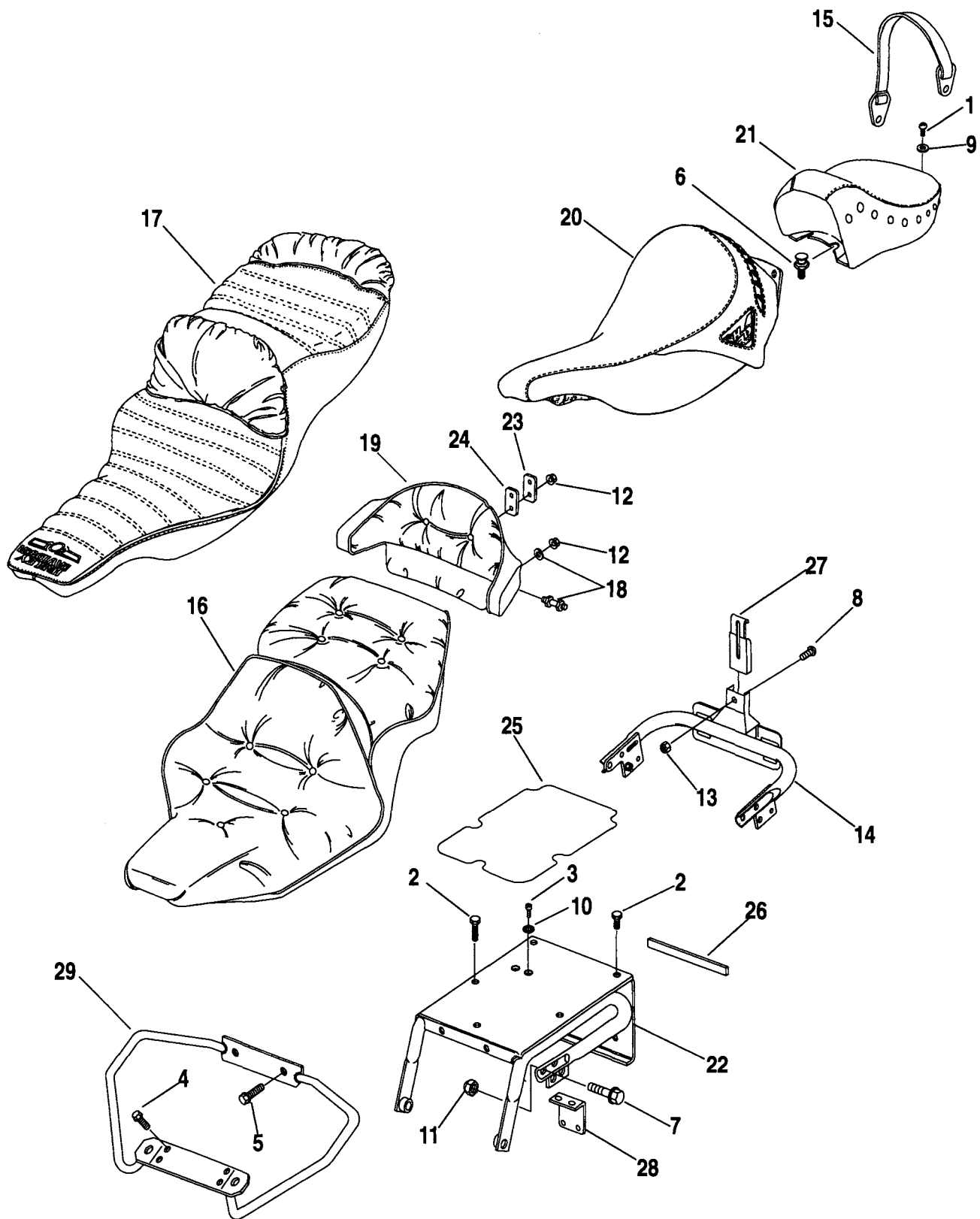

SEATS & LUGGAGE RACK - FLT MODELS

FB28

INDEX NO.	PART NO.	DESCRIPTION	FLT MODELS	FXR MODELS	SOFTAIL MODELS	DYNA MODELS
1	932	SCREW	94*-FD	--	--	--
2	2337W	SCREW (5-FA)	93-ALL; 94*-DJ/M/P	--	--	--
3	2443	SCREW (2)	93*-DM/P	--	--	--
4	3487	SCREW, flange (2)	93-ALL; 94*-DJ/M/P	--	--	--
5	3574	SCREW (2)	93-ALL; 94*-DJ/M/P	--	--	--
6	3608	STUD, seat mtg (2)	94*-FD	--	--	--
7	4327	SCREW (4)	93*-ALL	--	--	--
8	5403B	BOLT	94*-FD			
9	6410	WASHER (nylon)	94*-FD	--	--	--
10	7234	LOCKWASHER	93*-DM/P	--	--	--
11	7594	LOCKNUT (4)	93*-ALL	--	--	--
12	7716	NUT, flange (6)	93*-DJ/M/P	--	--	--
13	7792	NUT, keps	94*-FD	--	--	--
14	47440-92	REAR FRAME ASM.	94*-FD	--	--	--
15	51196-94	PASSENGER STRAP	94*-FD	--	--	--
16	52151-91A	SEAT (black)	93*-DM	--	--	--
	52164-91A	SEAT (black)	93*-DJ/P	--	--	--
17	52155-92A	SEAT, low (black)	93-FA	--	--	--
18	52192-86A	SET OF ISOLATORS	93*-DJ/M/P	--	--	--
19	52201-86B	BACKREST KIT (black)	93*-DJ/M/P	--	--	--
20	52280-94	SEAT, rider	94*-FD	--	--	--
21	52281-94	SEAT, passenger	94*-FD	--	--	--
22	53411-92A	LUGGAGE RACK	93-ALL 94*-DJ/M/P	--	--	--
23	53515-86	BACKING PLATE	93*-DJ/M/P	--	--	--
24	53517-86	CUSHION PLATE	93*-DJ/M/P	--	--	--
25	53521-91	COVER, luggage rack	93-FA	--	--	--
26	59988-72	REFLECTOR (red)	93*-ALL	--	--	--
27	60001-55	CLAMP	94*-FD	--	--	--
28	76284-89A	BRACKET, transceiver	93*-DM/P	--	--	--
29	91583-91A	HANDRAIL, passenger	93-ALL 94*-DJ/M/P	--	--	--

FLT MODELS

FLHTC DJ
 FLTC-U DM
 FLHTC-U DP
 FLHS FA
 FLHR FD

FXR MODELS

FXR EA
 FXRS-SP EG
 FXLR EL
 FXRS-CON EM

SOFTAIL MODELS

FLSTC BJ
 FXSTC BK
 FXSTS BL
 FLSTF BM
 FLSTN BN

DYNA MODELS

FXDL GD
 FXDWG GE
 FXDS-CON GG

SEATS & SISSY BAR - FXR

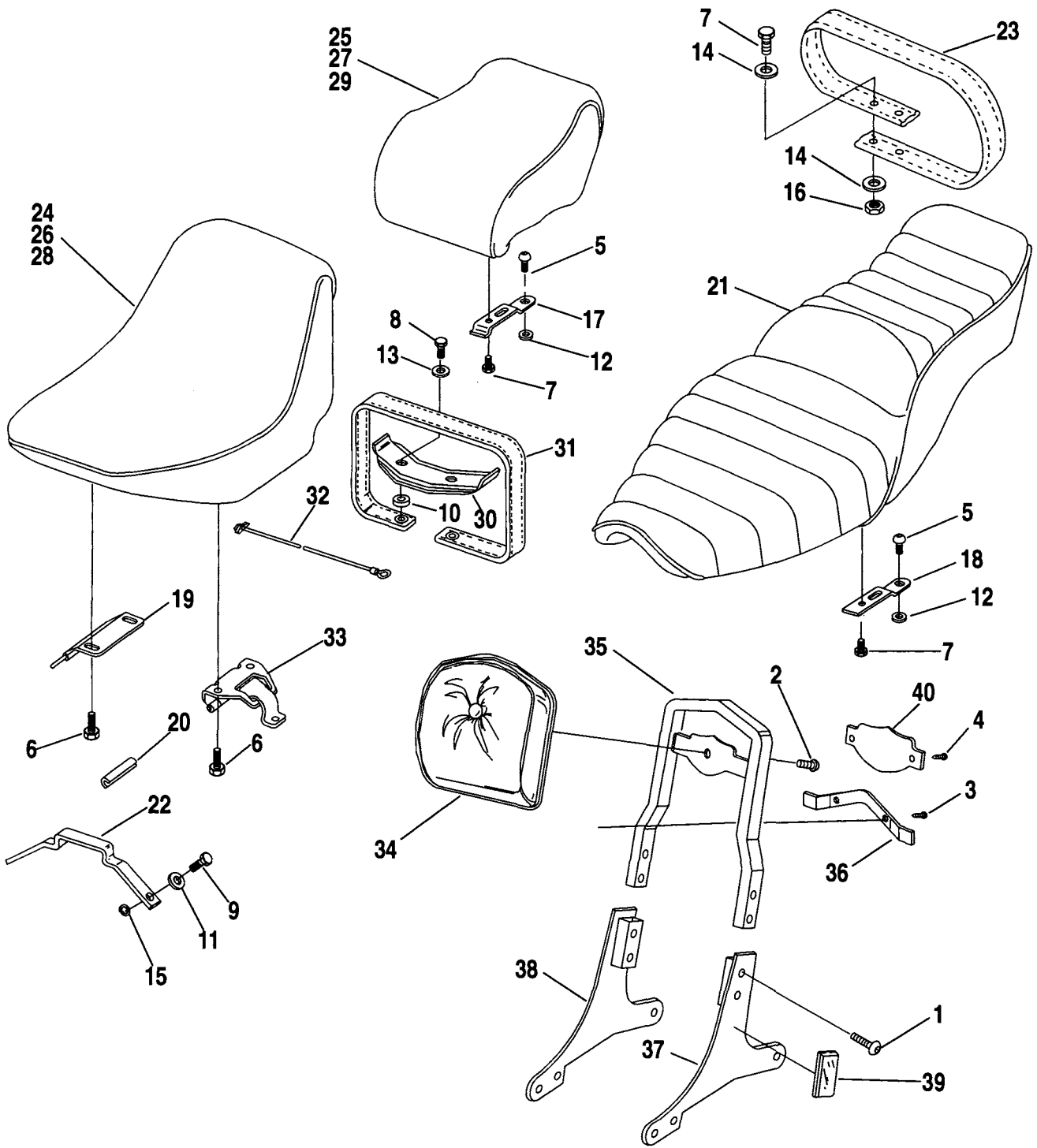

INDEX NO.	PART NO.	DESCRIPTION	FLT MODELS	FXR MODELS	SOFTAIL MODELS	DYNA MODELS
1	919	SCREW (4)	--	93*-EM	--	--
2	1602	SCREW	--	93*-EM	--	--
3	2607	SCREW (2)	--	93*-EM	--	--
4	2711	SCREW (2)	--	93*-EM	--	--
5	2733	SCREW	--	93*-EA	--	--
	2739	SCREW	--	93*-EG/L/M	--	--
6	3487	BOLT (4)	--	93*-ALL	--	--
7	3574	BOLT (2)	--	93*-ALL	--	--
8	3960W	BOLT (2)	--	93*-EG/L/M	--	--
9	3991	BOLT (2)	--	93*-EA	--	--
10	5724	SPACER (2)	--	93*-EG/L/M	--	--
11	6109	WASHER (2)	--	93*-EA	--	--
12	6410	WASHER (nylon)	--	93*-ALL	--	--
13	6645	WASHER (2)	--	93*-EG/L/M	--	--
14	6703	WASHER (2)	--	93*-EA	--	--
15	7232	LOCKWASHER (2)	--	93*-EA	--	--
16	7686	LOCKNUT	--	93*-EA	--	--
17	51651-79	BRACKET, rear seat	--	93*-EG/L/M	--	--
18	51652-83	BRACKET, rear seat	--	93*-EA	--	--
19	52020-82	BRACKET ASSEMBLY	--	93*-EG/L/M	--	--
20	52041-82	SLEEVE, hinge pin	--	93*-EG/L/M	--	--
21	52106-86A	SEAT, ribbed (black vinyl)	--	93*-EA	--	--
22	52107-86	BRACKET, seat	--	93*-EA	--	--
23	52108-86	PASSENGER STRAP	--	93*-EA	--	--
24	52128-87A	SEAT, plain - front (black vinyl)	--	93*-EG	--	--
25	52133-87A	SEAT, embossed - rear (black vinyl)	--	93*-EL	--	--
26	52134-87A	SEAT, embossed - front (black vinyl)	--	93*-EL	--	--
27	52135-87A	SEAT, plain - rear (black vinyl)	--	93*-EG	--	--
28	52138-82B	SEAT, pillow-look - front (black vinyl)	--	93*-EM	--	--
29	52139-82A	SEAT, pillow-look - rear (black vinyl)	--	93*-EM	--	--
30	52141-82	BRACKET, passenger strap	--	93*-EG/L/M	--	--
31	52142-82A	PASSENGER STRAP	--	93*-EG/L/M	--	--
32	52213-82	CORD, seat stop	--	93*-EG/L	--	--
33	52355-82	LATCH, seat	--	93*-EG/L	--	--
34	52545-84	BACKREST KIT w/ #2 & 36	--	93*-EM	--	--
35	52739-83	SISSY BAR KIT w/ #1	--	93*-EM	--	--
36	52771-82	BRACKET, backrest	--	93*-EM	--	--
37	52797-87	SIDE PLATE, left	--	93*-EM	--	--
38	52798-87	SIDE PLATE, right	--	93*-EM	--	--
39	59267-83A	REFLECTOR (red) (2)	--	93*-EM	--	--
40	99013-82	MEDALLION	--	93*-EM	--	--
		H-D INTERNATIONAL ONLY				
39	59270-84A	REFLECTOR (amber)(2)(HDI only)	--	93*-EM	--	--

SEATS & SISSY BAR - SOFTTAIL

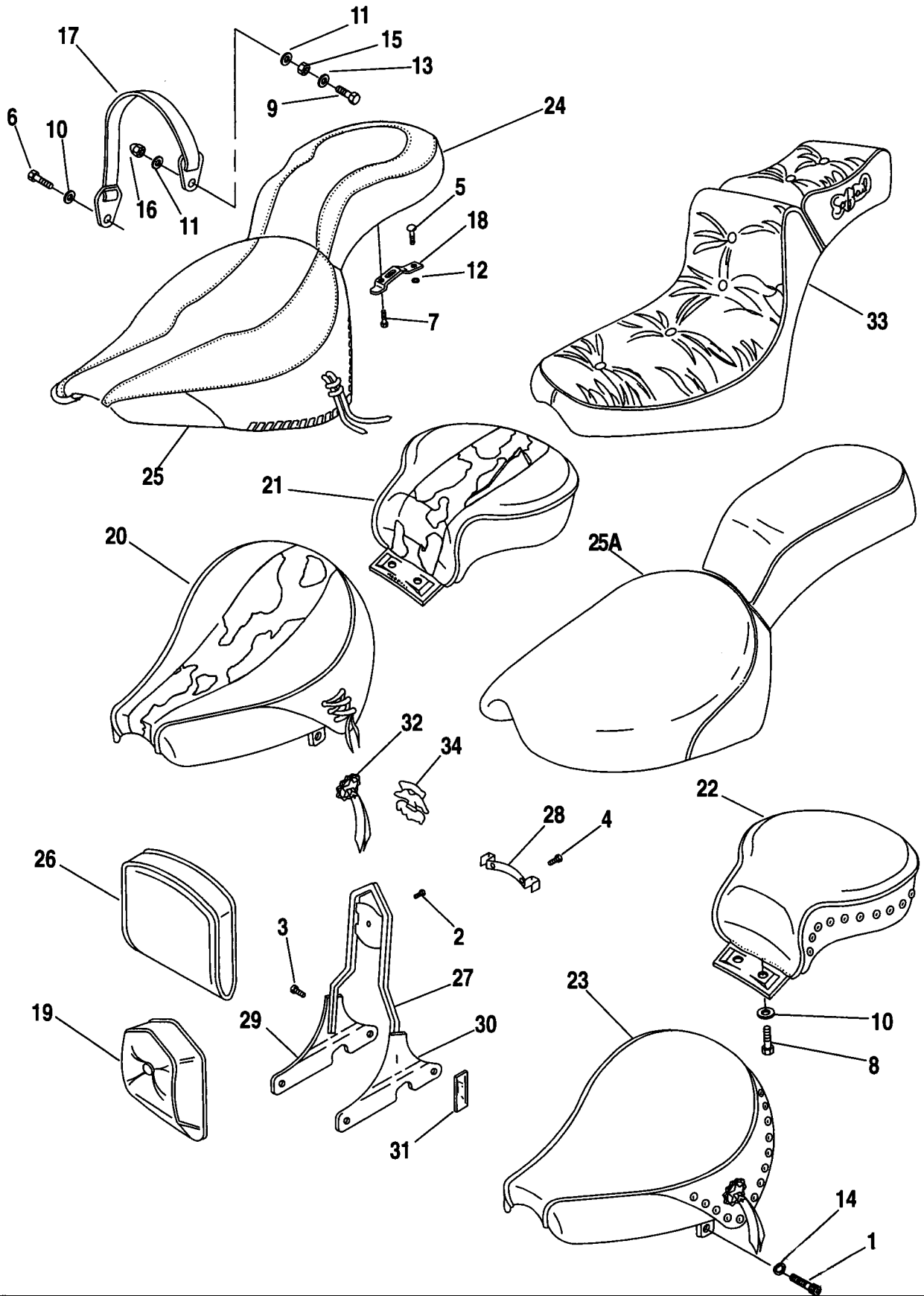

SEATS & SISSY BAR - SOFTAIL MODELS

FB28B

INDEX NO.	PART NO.	DESCRIPTION	FLT MODELS	FXR MODELS	SOFTAIL MODELS	DYNA MODELS
1	868	SCREW (2)	--	--	93*-BJ/M/N	--
2	1357W	SCREW	--	--	93*-BJ/K	--
3	3793	SCREW (4)	--	--	93*-BJ/K	--
4	2538	SCREW (2)	--	--	93*-BJ	--
	2607	SCREW (2)	--	--	93*-BK	--
5	2739	SCREW	--	--	93*-ALL	--
6	2879W	BOLT (2)	--	--	93*-BJ/K	--
7	3574	BOLT (2)	--	--	93*-ALL	--
8	3974HW	BOLT (2)	--	--	93*-BJ/N	--
9	4721	BOLT (2)	--	--	93*-BJ/M	--
10	6333	WASHER (2)	--	--	93*-BJ/N	--
11	6379W	WASHER (4)	--	--	93*-BJ/M	--
12	6410	WASHER (nylon)	--	--	93*-ALL	--
13	6701	WASHER (2)	--	--	93*-BJ/M	--
14	7068	LOCKWASHER (2)	--	--	93*-BJ/M/N	--
15	7643W	JAM NUT (2)	--	--	93*-BJ/M	--
16	7680W	ACORN NUT (2)	--	--	93*-BJ/M	--
17	51184-88	PASSENGER STRAP (black)	--	--	93*-BL	--
	51185-90	PASSENGER STRAP (black)	--	--	93*-BJ	--
	51186-89	PASSENGER STRAP (black)	--	--	93*-BM	--
	51188-86	PASSENGER STRAP (black)	--	--	93*-BK	--
	51190-92	PASSENGER STRAP (black)	--	--	93*-BN	--
18	51652-83	BRACKET, seat	--	--	93*-ALL	--
19	52191-86	BACKREST	--	--	93*-BK	--
20	52203-93A	SEAT, front	--	--	93*-BN	--
	52283-94	SEAT, front	--	--	94*-BN	--
21	52204-93	SEAT, rear	--	--	93*-BN	--
	52285-94	SEAT, rear	--	--	94*-BN	--
22	52208-86A	SEAT KIT, passenger (black)	--	--	93*-BJ	--
23	52236-86B	SEAT KIT, solo (black)	--	--	93*-BJ	--
24	52209-90A	SEAT w/textured panel (rear)	--	--	93*-BM	--
25	52217-90B	SEAT, w/textured panel (front)	--	--	93*-BM	--
25A	52503-88D	SEAT	--	--	93*-BL	--
26	52541-87	BACKREST KIT w/ concho (black)	--	--	93*-BJ	--
27	52735-85	UPRIGHT, sissy bar	--	--	93*-BJ/K	--
28	52771-82	BRACKET, backrest	--	--	93*-BJ/K	--
29	52787-92	SIDE PLATE, right	--	--	93*-BJ/K	--
30	52788-92	SIDE PLATE, left	--	--	93*-BJ/K	--
31	59255-91	REFLECTOR (red) (2)	--	--	93*-BJ	--
32	91850-87	CONCHO	--	--	93*-BJ	--
33	91768-85B	SEAT (black)	--	--	93*-BK	--
34	99000-77	MEDALLION	--	--	93*-BK	--

H-D INTERNATIONAL ONLY

31	59254-91	REFLECTOR (amber) (2) (HDI only)	--	--	93*-BK	--
----	----------	----------------------------------	----	----	--------	----

FLT MODELS

FLHTC DJ
 FLTC-U DM
 FLHTC-U DP
 FLHS FA
 FLHR FD

FXR MODELS

FXR EA
 FXRS-SP EG
 FXLR EL
 FXRS-CON EM

SOFTAIL MODELS

FLSTC BJ
 FXSTC BK
 FXSTS BL
 FLSTF BM
 FLSTN BN

DYNA MODELS

FXDL GD
 FXDWG GE
 FXDS-CON GG

SEATS & SISSY BAR - DYNA

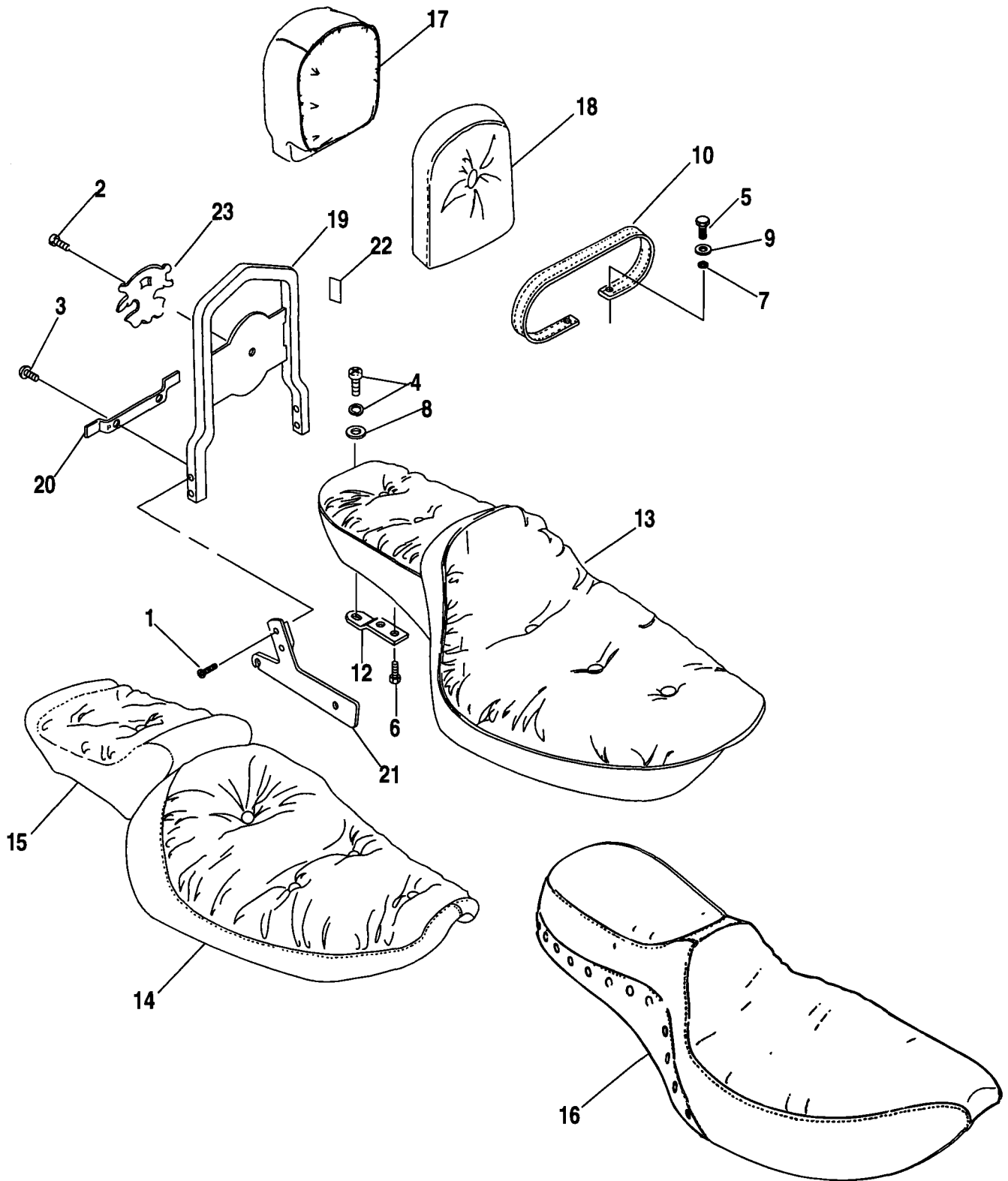

INDEX NO.	PART NO.	DESCRIPTION	FLT MODELS	FXR MODELS	SOFTAIL MODELS	DYNA MODELS
1	919	SCREW (4)	--	--	--	93*-ALL
2	1357W	SCREW	--	--	--	93*-ALL
3	2607	SCREW (2)	--	--	--	93*-ALL
4	2739	SCREW	--	--	--	93*-ALL
5	2871W	SCREW	--	--	--	93*-ALL
6	3574	SCREW (2)	--	--	--	93*-ALL
7	6237	WASHER	--	--	--	93*-ALL
8	6410	WASHER	--	--	--	93*-ALL
9	6702	WASHER	--	--	--	93*-ALL
10	51188-84	PASSENGER STRAP	--	--	--	93*-ALL
12	51652-83	BRACKET, seat	--	--	--	93*-ALL
13	52166-93	SEAT	--	--	--	93*-GE
14	52174-93	SEAT, front	--	--	--	93*-GD
15	52175-93	SEAT, rear	--	--	--	93*-GD
16	52183-94	SEAT	--	--	--	94*-GG
17	52543-94	BACKREST	--	--	--	94*-GG
18	52545-84	BACKREST PAD KIT w/#2	--	--	--	93*-GE
19	52655-84	SISSY BAR	--	--	--	93*-GE
	52739-83	SISSY BAR KIT, w/ #1	--	--	--	94*-GG
20	52771-82	BRACKET, backrest	--	--	--	93*-GE/G
21	52780-90A	SIDEPLATE, right	--	--	--	94*-GG
	52799-90A	SIDEPLATE, left	--	--	--	94*-GG
	52800-93	SIDEPLATE, right	--	--	--	93*-GE
	52801-93	SIDEPLATE, left	--	--	--	93*-GE
22	53554-81	LABEL, bolt torque	--	--	--	93*-GE
23	97000-93	MEDALLION (90th Anniversary)	--	--	--	93-GE
	99000-77	MEDALLION (Made in U. S. A.)	--	--	--	93*-GE/G

FLT MODELS

FLHTC DJ
 FLTC-U DM
 FLHTC-U DP
 FLHS FA
 FLHR FD

FXR MODELS

FXR EA
 FXRS-SP EG
 FXLR EL
 FXRS-CON EM

SOFTAIL MODELS

FLSTC BJ
 FXSTC BK
 FXSTS BL
 FLSTF BM
 FLSTN BN

DYNA MODELS

FXDL GD
 FXDWG GE
 FXDS-CON GG

FOOTRESTS

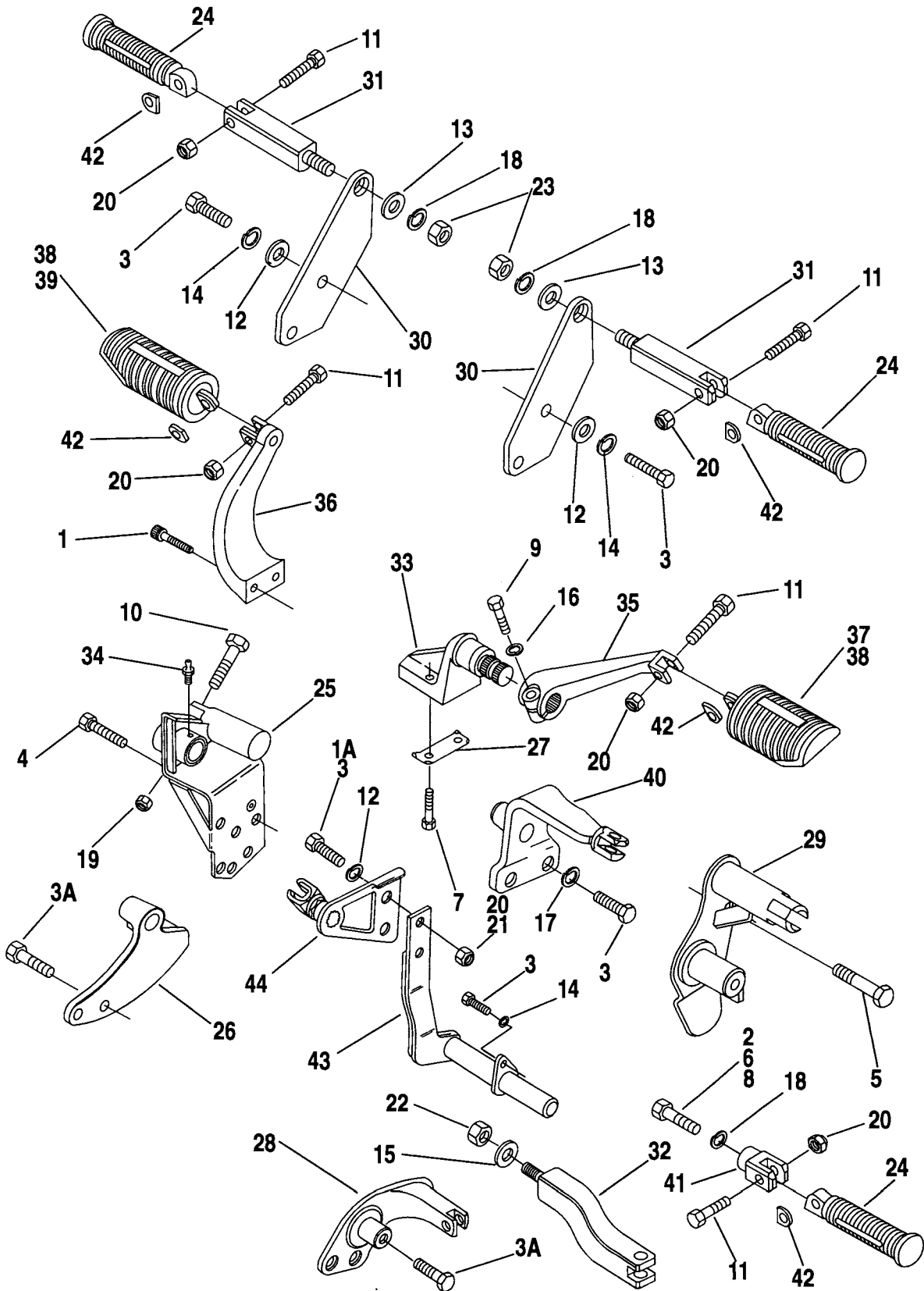

INDEX NO.	PART NO.	DESCRIPTION	FLT MODELS	FXR MODELS	SOFTAIL MODELS	DYNA MODELS
1	856A	SCREW (2)	--	93*-ALL	--	--
1A	861A	BOLT (2)	--	--	--	94*-ALL
2	872A	BOLT - right	--	--	93*-BM/N	--
3	2851	BOLT (4 - EL/M)	--	93*-EL/M	--	93*-ALL
	3214	BOLT (2-GE-1993;10-GD-1993;9-GD-1994)	--	--	--	93*-ALL
3A	4059	SCREW (4)	--	--	--	93*-GE
4	3440	BOLT	--	--	93*-ALL	--
5	3464	BOLT	--	--	93*-BK/L	--
6	3486	BOLT (2)	--	93*-ALL	--	--
7	3503	BOLT (2)	--	93*-ALL	--	--
8	3516A	BOLT (2)	--	--	93*-BK/L/ M/N	--
	3549A	BOLT (2)	--	--	93*-BJ	--
9	4014W	BOLT (2)	--	93*-ALL	--	--
10	4716W	SCREW	--	--	93*-BK/L	--
11	4721	BOLT (as required)	--	93*-ALL	93*-ALL	93*-ALL
12	6701	WASHER (4;6-DYNA-1993)	--	93*-EL/M	--	93*-ALL
13	6718	WASHER (2)	--	93*-EL/M	--	93*-GD/G
14	7038	LOCKWASHER (2; 4-EL/M)	--	93*-EL/M	--	93*-ALL
15	7039	LOCKWASHER	--	--	--	93*-ALL
16	7041	LOCKWASHER	--	93*-ALL	--	--
17	7045	LOCKWASHER (4)	--	--	--	93*-ALL
18	7068	LOCKWASHER (as required)	--	93*-ALL	93*-ALL	93*-ALL
19	7667	LOCKNUT	--	--	93*-BK/L	--
20	7778	LOCKNUT (4-EL/M,GE,GD;8-GE,10-GD-1994)	--	93*-ALL	93*-ALL	93*-ALL
21	7782	LOCKNUT (2)	--	--	--	93*-ALL
22	7848W	LOCKNUT (2)	--	--	--	93*-ALL
23	7880	NUT (2)	--	93*-EG/M	--	93*-GD/G
24	33048-72	FOOTREST w/ cover (2; 4-BK,EL/M,GE)	--	93*-ALL	93*-ALL	93*-ALL
	33189-63	COVER, (black) (2; 4-BK,EL/M,GE)	--	93*-ALL	93*-ALL	93*-ALL

FLT MODELS

FLHTC DJ
 FLTC-U DM
 FLHTC-U DP
 FLHS FA
 FLHR FD

FXR MODELS

FXR EA
 FXRS-SP EG
 FXLR EL
 FXRS-CON EM

SOFTAIL MODELS

FLSTC BJ
 FXSTC BK
 FXSTS BL
 FLSTF BM
 FLSTN BN

DYNA MODELS

FXDL GD
 FXDWG GE
 FXDS-CON GG

FOOTRESTS

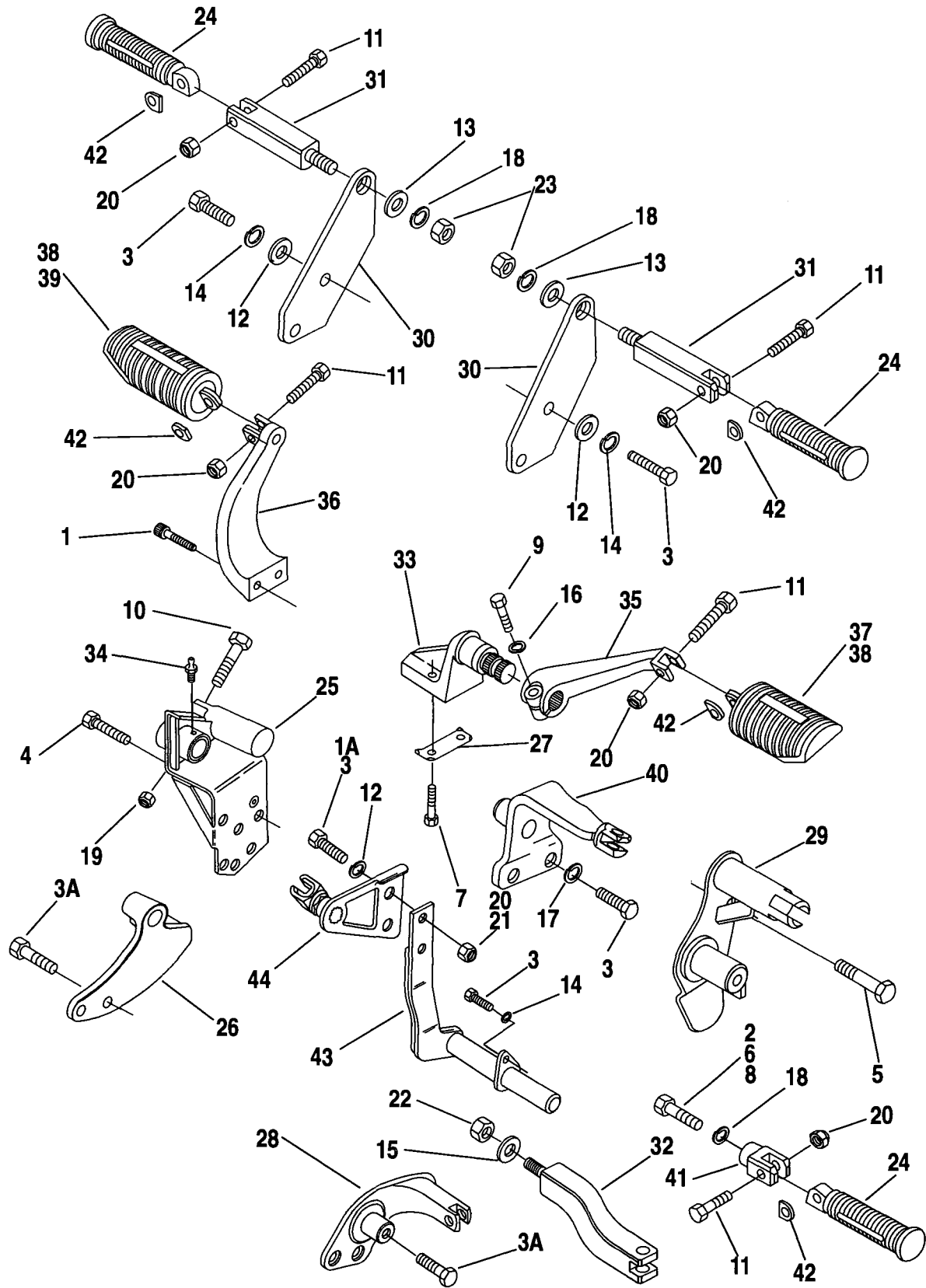

FOOTRESTS (CONT'D)

FB29-2

INDEX NO.	PART NO.	DESCRIPTION	FLT MODELS	FXR MODELS	SOFTAIL MODELS	DYNA MODELS
25	33683-90	BRACKET, shifter & footrest	--	--	93-BK/L	--
	33683-94	BRACKET, shifter & footrest	--	--	94*-BK/L	--
26	33693-93	BRACKET, shifter & footrest	--	--	--	93*-GE
27	42334-82	LOCKPLATE, front	--	93*-ALL	--	--
28	42481-92	BRACKET, brake lever & footrest	--	--	--	93*-GE
29	42507-89A	BRACKET, brake lever & footrest	--	--	93*-BK/L	--
30	49126-77B	MOUNTING PLATE (2)	--	93*-EL/M	--	--
	49126-90	MOUNTING PLATE (2)	--	--	--	93*-GD/G
31	49127-77A	FOOTREST SUPPORT (2)	--	93*-EL/M	--	93*-ALL
32	49165-90	FOOTREST SUPPORT	--	--	--	93*-ALL
33	50531-81	BRACKET, footrest - front	--	93*-ALL	--	--
34	50972-75	FITTING, lubrication	--	--	93*-BK/L	--
35	50636-81A	BRACKET, right footrest - front	--	93*-ALL	--	--
36	50639-81	BRACKET, left footrest - front	--	93*-ALL	--	--
	50639-90	BRACKET, left footrest - front	--	--	--	93*-GD/G
37	50643-82	FOOTREST w/ cover - right (2-GD/G)	--	93*-ALL	--	93*-GD/G
38	50646-82	COVER, only (black) (2; 4-GD/G)	--	93*-ALL	--	93*-GD/G
39	50647-82	FOOTREST, w/ cover - left (2-GD/G)	--	93*-ALL	--	93*-GD/G
40	50649-90	BRACKET, right, footrest - front	--	--	--	93*-GD/G
41	50900-72	SUPPORT, passenger footrest	--	93*-ALL	93*-ALL	--
42	50912-72	SPRING WASHER (as required)	--	93*-ALL	93*-ALL	93*-ALL
43	52721-90	UPRIGHT BRACKET, left	--	--	--	93-ALL
	52740-94	UPRIGHT BRACKET, left	--	--	--	94*-ALL
44	52729-90	SUPPORT, left	--	--	--	93-ALL
	52742-94	SUPPORT, left	--	--	--	94*-ALL

FLT MODELS

FLHTC DJ
 FLTC-U DM
 FLHTC-U DP
 FLHS FA
 FLHR FD

FXR MODELS

FXR EA
 FXRS-SP EG
 FXLR EL
 FXRS-CON EM

SOFTAIL MODELS

FLSTC BJ
 FXSTC BK
 FXSTS BL
 FLSTF BM
 FLSTN BN

DYNA MODELS

FXDL GD
 FXDWG GE
 FXDS-CON GG

FOOTBOARDS

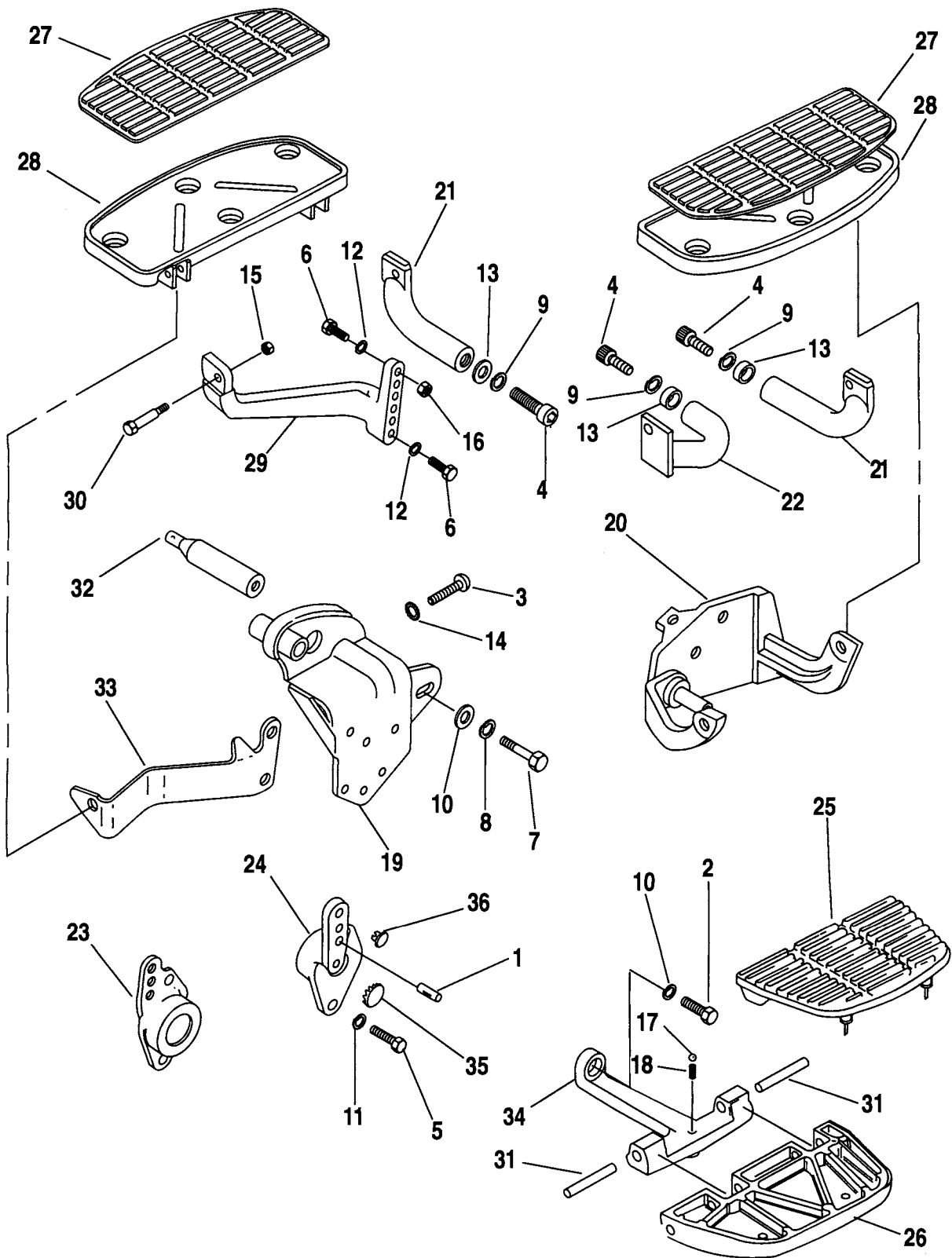

INDEX NO.	PART NO.	DESCRIPTION	FLT MODELS	FXR MODELS	SOFTAIL MODELS	DYNA MODELS
1	276	DOWEL PIN (2)	93*-ALL	--	--	--
2	861A	SCREW (2)	93*-ALL	--	--	--
3	2773	SCREW	--	--	93*-BJ/M/N	--
4	3599	SCREW (3)	93*-ALL	--	--	--
5	3782	BOLT (4)	93*-ALL	--	--	--
6	4017	SCREW (2)	92*-ALL	--	--	--
7	4721	BOLT	--	--	93*-BJ/M/N	--
8	6400HB	WASHER	--	--	93*-BJ/M/N	--
9	6738	WASHER (3)	93*-ALL	--	--	--
10	7038	LOCKWASHER (2-FLT)	93*-ALL	--	93*-BJ/M/N	--
11	7039	LOCKWASHER (4)	93*-ALL	--	--	--
12	7041	LOCKWASHER (2)	93*-ALL	--	--	--
13	7068	LOCKWASHER (3)	93*-ALL	--	--	--
14	7230	LOCKWASHER	--	--	93*-BJ/M/N	--
15	7716	LOCKNUT (4)	93*-ALL	--	93*-BJ/M/N	--
16	7748W	NUT	93*-ALL	--	--	--
17	8860	BALL (2)	93*-ALL	--	--	--
18	33085-74	SPRING (2)	93*-ALL	--	--	--
19	33630-90	BRACKET, left	--	--	93-BJ/M/N	--
	33630-94	BRACKET, left	--	--	94*-BJ/M/N	--
20	42431-87	BRACKET	--	--	93*-BJ/M/N	--
21	47365-83A	BRACKET KIT, front w/# 4 (2)	93*-ALL	--	--	--
22	50518-83A	BRACKET KIT, right rear w/# 4	93*-ALL	--	--	--
23	50588-93	BRACKET, left	93*-ALL	--	--	--
24	50589-93	BRACKET, right	93*-ALL	--	--	--
25	50606-86A	PAD (2)	93*-ALL	--	--	--
26	50613-91	FOOTBOARD, passenger (2)	93*-ALL	--	--	--
27	50614-91	PAD (2)	93*-ALL	--	93*-BJ/M/N	--
28	50621-79A	FOOTBOARD, w/# 27 (2)	93*-ALL	--	93*-BJ/M/N	--
29	50622-83B	BRACKET KIT, left rear w/# 6	93*-ALL	--	--	--
30	50635-82	BOLT, footboard hinge (4)	93*-ALL	--	93*-BJ/M/N	--
31	50933-86	PIN, pivot (4)	93*-ALL	--	--	--
32	50989-86	STUD, left front (chrome)	--	--	93*-BJ/M/N	--
33	50990-86B	SUPPORT BRACKET, left rear	--	--	93*-BJ/M/N	--
34	52719-93	SUPPORT KIT w/ #1, footboard (2)	93*-ALL	--	--	--
35	67865-89	PLUG (2)	93*-ALL	--	--	--
36	90493-83	PLUG (2)	93*-ALL	--	--	--

FLT MODELS
 FLHTC DJ
 FLTC-U DM
 FLHTC-U DP
 FLHS FA
 FLHR FD

FXR MODELS
 FXR EA
 FXRS-SP EG
 FXLR EL
 FXRS-CON EM

SOFTAIL MODELS
 FLSTC BJ
 FXSTC BK
 FXSTS BL
 FLSTF BM
 FLSTN BN

DYNA MODELS
 FXDL GD
 FXDWG GE
 FXDS-CON GG

LUGGAGE BOX (KING TOUR-PAK)

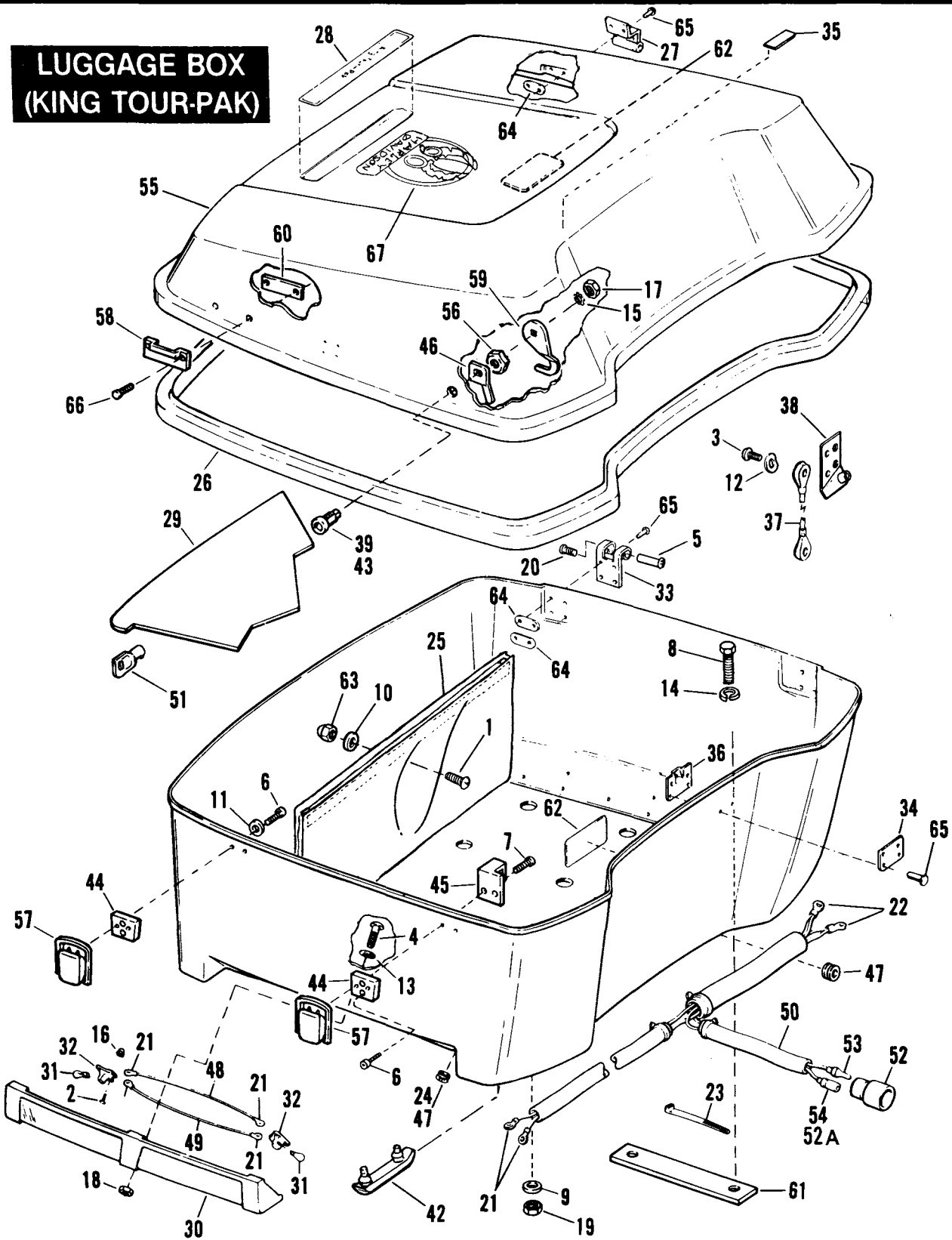

LUGGAGE BOX (KING TOUR-PAK)

FB30-1

INDEX NO.	PART NO.	DESCRIPTION	FLT MODELS	FXR MODELS	SOFTAIL MODELS	DYNA MODELS
1	2724	SCREW (2)	93*-DJ	--	--	--
2	2804W	SCREW (8)	93*-DJ/M/P	--	--	--
3	2831	SCREW	93*-DJ/M/P	--	--	--
4	2888	SCREW (6)	93*-DJ/M/P	--	--	--
5	3595	SCREW (2)	93*-DJ/M/P	--	--	--
6	3597	SCREW (4)	93*-DJ/M/P	--	--	--
7	3598	SCREW (2)	93*-DJ/M/P	--	--	--
8	4702	BOLT (4)	93*-DJ	--	--	--
9	6703	WASHER (6)	93*-DJ/M/P	--	--	--
10	6716	WASHER (2)	93*-DJ	--	--	--
11	6717	WASHER (4)	93*-DJ/M/P	--	--	--
12	6970	SPRING WASHER	93*-DJ/M/P	--	--	--
13	7115	LOCKWASHER (6)	93*-DJ/M/P	--	--	--
14	7124	LOCKWASHER	93*-DJ/M/P	--	--	--
15	7128	LOCKWASHER	93*-DJ/M/P	--	--	--
16	7520	ACORN NUT (nylon) (8)	93*-DJ/M/P	--	--	--
17	7586	NUT	93*-DJ/M/P	--	--	--
18	7608	LOCKNUT (6)	93*-DJ/M/P	--	--	--
19	7686	NUT (6)	93*-DJ/M/P	--	--	--
20	8500A	HINGE PIN KIT w/ #5 (2)	93*-DJ/M/P	--	--	--
21	9856	TERMINAL, ring type - No. 6 hole (10)	93*-DJ	--	--	--
22	9871	TERMINAL, ring type - No. 6 hole (2)	93*-DJ	--	--	--
23	10065	CABLE STRAP (3)	93*-DJ	--	--	--
24	11410	GROMMET, side light wiring (2)	93*-DJ	--	--	--
25	53165-89A	POUCH	93*-DJ	--	--	--
26	53415-83	GASKET, cover	93*-DJ/M/P	--	--	--
27	53426-87	HINGE, cover - upper (2)	93*-DJ/M/P	--	--	--
28	53434-80	NAMEPLATE, "KING TOUR-PAK" (black)	93*-DJ	--	--	--
29	53435-88	MAT, luggage box	93*-DJ	--	--	--
30	53437-79	LENS, side light (2)	93*-DJ/M/P	--	--	--
31	53439-79	BULB, side light (4)	93*-DJ/M/P	--	--	--
32	53440-79	SOCKET, side light (4)	93*-DJ/M/P	--	--	--
33	53447-87	HINGE, lower (2)	93*-DJ/M/P	--	--	--
34	53478-80	BACKING PLATE, brace	93*-DJ/M/P	--	--	--
35	53486-85	PAD (2)	93*-DJ/M/P	--	--	--
36	53563-82	BRACKET, cable mounting	93*-DJ/M/P	--	--	--
37	53564-89	CABLE BRACE, cover	93*-DJ/M/P	--	--	--
38	53570-89	BRACKET, cable mounting	93*-DJ/M/P	--	--	--
39	53584-92	LOCK	93*-DJ/M/P	--	--	--

FLT MODELS

FLHTC
FLTC-U
FLHTC-U
FLHS
FLHR

DJ
DM
DP
FA
FD

FXR MODELS

FXR
FXRS-SP
FXLR
FXRS-CON
EM

EA
EG
EL
EM

SOFTAIL MODELS

FLSTC
FXSTC
FXSTS
FLSTF
FLSTN

BJ
BK
BL
BM
BN

DYNA MODELS

FXDL
FXDWG
FXDS-CON
GG

GD
GE

LUGGAGE BOX (KING TOUR-PAK)

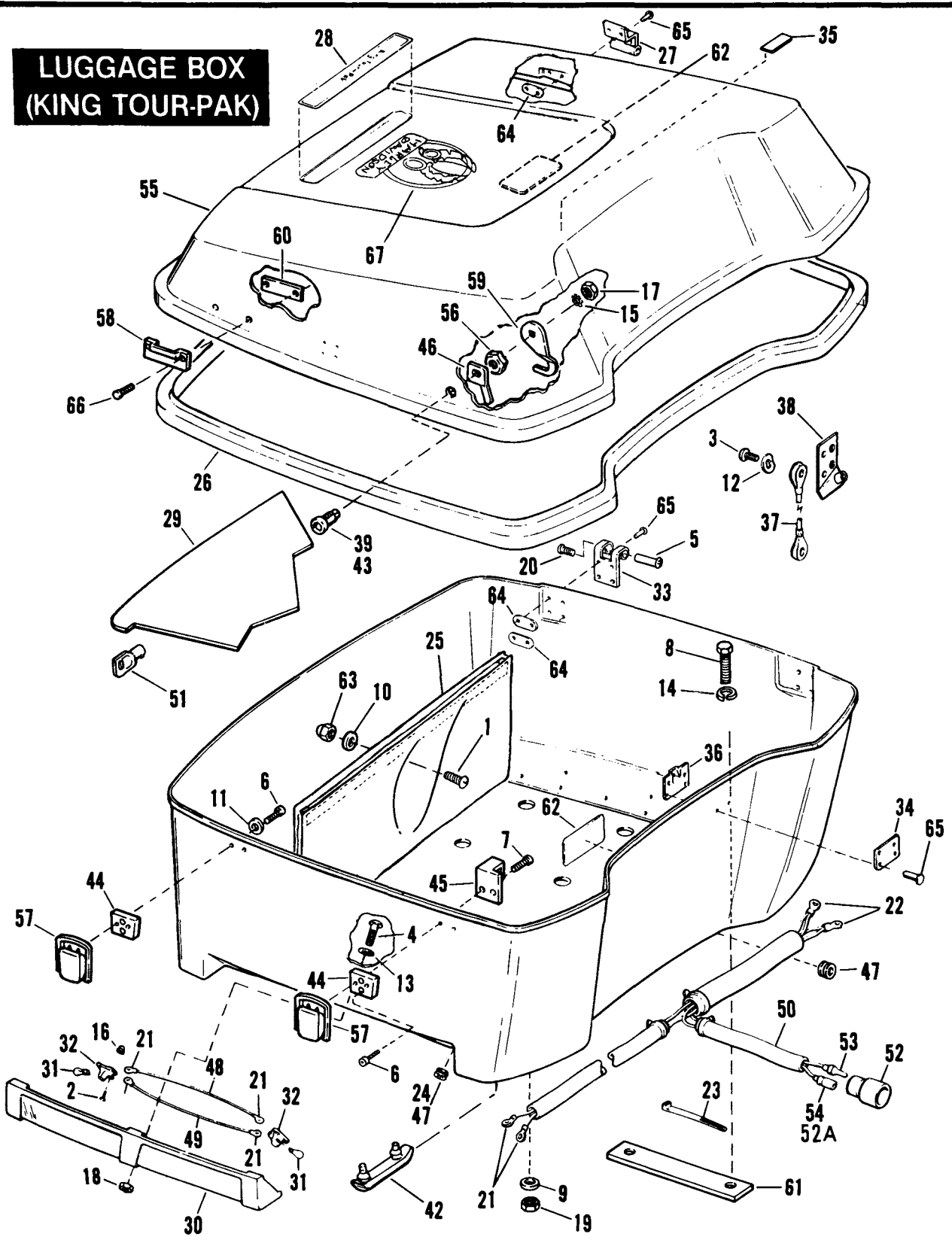

LUGGAGE BOX (KING TOUR-PAK) (CONT'D)

FB30-2

INDEX NO.	PART NO.	DESCRIPTION	FLT MODELS	FXR MODELS	SOFTAIL MODELS	DYNA MODELS
41	53275-90	BOTTOM, Tour-Pak (Prime)	93*-DJ/M/P	--	--	--
42	53429-93	BUMPER (2)	93*-DJ	--	--	--
43	53574-93	LOCK SET, complete vehicle	93*-DJ/P	--	--	--
	53575-93	LOCK SET, complete vehicle	93*-DM	--	--	--
44	53615-85	SPACER (2)	93*-DJ/M/P	--	--	--
45	53616-85	CATCH, lower	93*-DJ/M/P	--	--	--
46	53617-85	GUIDE, lock	93*-DJ	--	--	--
47	57978-63	GROMMET (3)	93*-DJ/M/P	--	--	--
	58709-86	RIVET (2)	93*-DJ/M/P	--	--	--
48	70643-79B	WIRE, side light (green) (2)	93-DJ/M/P	--	--	--
49	70644-79A	WIRE, side light (black) (2)	93-DJ/M/P	--	--	--
50	70646-90	WIRING HARNESS, side light	93-DJ	--	--	--
	70646-94	WIRING HARNESS	94*-DJ	--	--	--
	70648-89	WIRING HARNESS, luggage box	93-DM/P	--	--	--
51	71452-91A	KEY (Specify key No.)	93*-DJ/M/P	--	--	--
52	72052-79	RECEPTACLE, side light wire	93-DJ	--	--	--
	74521-77	RECEPTACLE, luggage box	93-DM/P	--	--	--
52A	72191-94	TERMINAL, socket	94*-DJ	--	--	--
53	74536-77A	PIN, wiring harness	93-DJ/M/P	--	--	--
54	74539-77A	SOCKET, wiring harness (2-DM/P)	93-DJ/M/P	--	--	--
55	79041-90	COVER, Tour-Pak (Prime)	93*-DJ/M/P	--	--	--
56	84850-92	NUT, lock	93*-DJ/M/P	--	--	--
57	90649-85	BODY, catch (2)	93*-DJ/M/P	--	--	--
58	90663-85	CATCH, upper (2)	93*-DJ/M/P	--	--	--
59	90686-92	CAM HOOK	93*-DJ/M/P	--	--	--
60	90688-85	BACKING PLATE (2)	93*-DJ/M/P	--	--	--
61	90743-88	GASKET (2)	93*-DJ/M/P	--	--	--
62	90821-74A	LABEL, load limit	93*-DJ/M/P	--	--	--
63	90844-80	ACORN NUT (2)	93*-DJ	--	--	--
64	90964-63	BACKING PLATE (8)	93*-DJ/M/P	--	--	--
65	90965-63	RIVET (12)	93*-DJ/M/P	--	--	--
66	90967-64	RIVET (4)	93*-DJ/M/P	--	--	--
67	97001-93	MEDALLION (90th anniversary)	93-DJ/M/P	--	--	--

FLT MODELS

FLHTC
FLTC-U
FLHTC-U
FLHS
FLHR

DJ
DM
DP
FA
FD

FXR MODELS

FXR
FXRS-SP
FXLR
FXRS-CON

EA
EG
EL
EM

SOFTAIL MODELS

FLSTC
FXSTC
FXSTS
FLSTF
FLSTN

BJ
BK
BL
BM
BN

DYNA MODELS

FXDL
FXDWG
FXDS-CON

GD
GE
GG

LAMPS & SPEAKER HOUSING - ULTRA TOUR-PAK

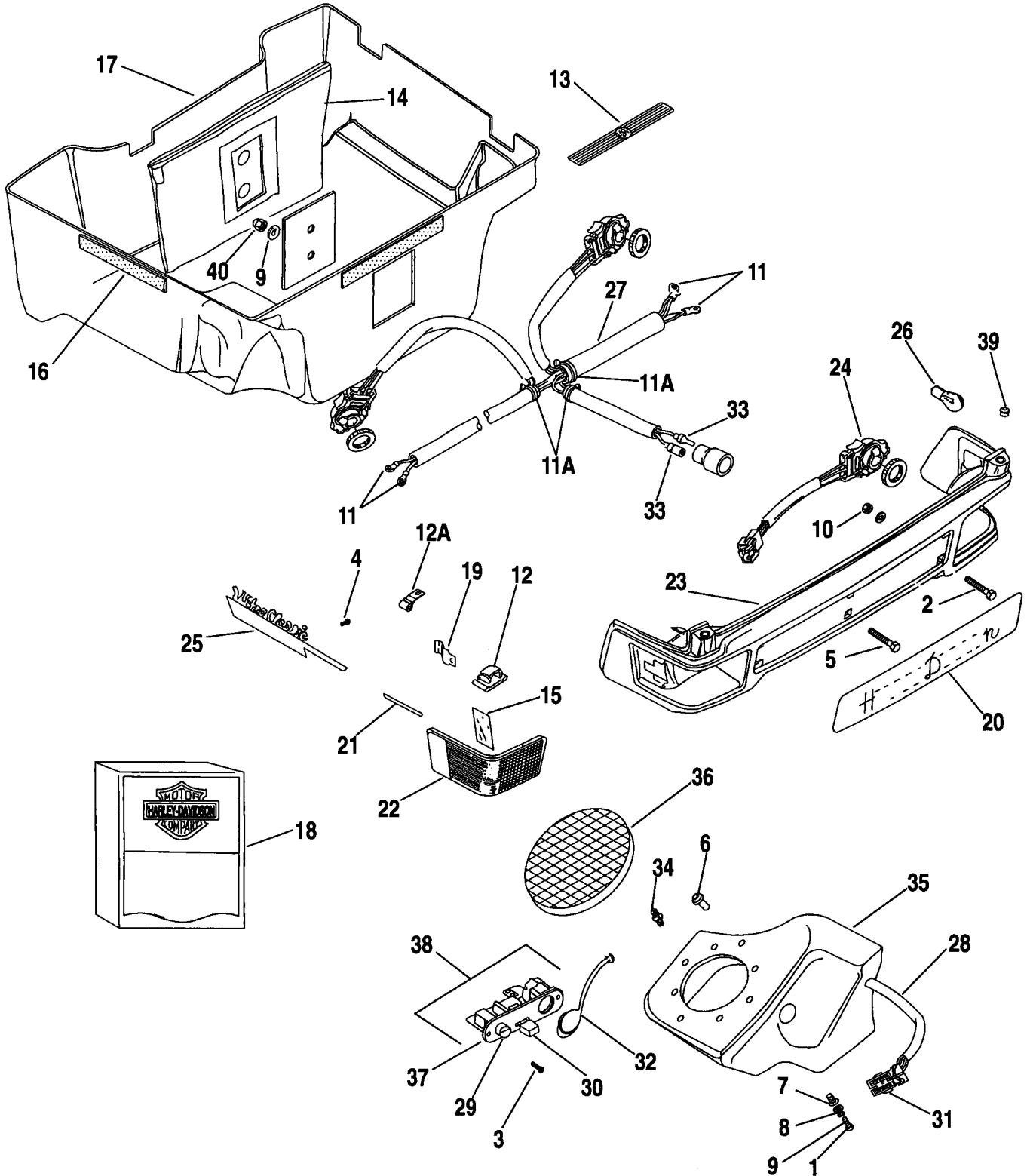

INDEX NO.	PART NO.	DESCRIPTION	FLT MODELS	FXR MODELS	SOFTAIL MODELS	DYNA MODELS
1	2551W	BOLT (6)	93*-DM/P	--	--	--
2	3541	SCREW (4)	93*-DM/P	--	--	--
3	3556A	SCREW (2)	93*-DM/P	--	--	--
4	3595	SCREW (6)	93*-DM/P	--	--	--
5	3606	SCREW (2)	93*-DM/P	--	--	--
6	5210	WELL NUT (8)	93*-DM/P	--	--	--
7	5211	NUT, crimp	93*-DM/P	--	--	--
8	6036	WASHER (6)	93*-DM/P	--	--	--
9	7036	LOCKWASHER (6)	93*-DM/P	--	--	--
10	7878	NUT (6)	93*-DM/P	--	--	--
11	9871	TERMINAL, ring type #6 hole (4)	94*-DM/P	--	--	--
11A	10065	CABLE STRAP (3)	94*-DM/P	--	--	--
12	10120	CLIP, antenna cable (4)	93-DM/P	--	--	--
12A	10143	CLIP, antenna cable (4)	94*-DM/P	--	--	--
13	14218-89	DECAL "USA" (silver)	93*-DM/P	--	--	--
	14251-90	DECAL "USA" (black)	93*-DM/P	--	--	--
	14413-94	DECAL "USA" (burgundy)	93*-DM/P	--	--	--
14	53165-89A	POUCH, owner's manual	93*-DM/P	--	--	--
15	53166-89	REFLECTOR (2)	93*-DM/P	--	--	--
16	53170-89	FASTENER (velcro) (5) (Cut to suit.)	93*-DM/P	--	--	--
17	53278-89C	LINER, molded	93*-DM/P	--	--	--
18	53598-88	LINER, removable	93*-DM/P	--	--	--
19	58380-89	CLIP, housing (2)	93*-DM/P	--	--	--
20	58381-89	NAMEPLATE	93*-DM/P	--	--	--
21	58382-89	SEAL, lamp lens (4)	93*-DM/P	--	--	--
22	58383-89	LENS, left	93*-DM/P	--	--	--
	58384-89	LENS, right	93*-DM/P	--	--	--
23	58385-93	HOUSING, lamp	93*-DM/P	--	--	--
24	58388-89	SOCKET ASSEMBLY (2)	93-DM/P	--	--	--
25	59225-93	TRIM, left	93*-DM/P	--	--	--
	59226-93	TRIM, right	93*-DM/P	--	--	--
26	68168-89	BULB, taillamps	93*-DM/P	--	--	--
27	70648-94	WIRING HARNESS	94*-DM/P	--	--	--
28	70649-91	HARNESS, rear speaker - right	93-DM/P	--	--	--
29	71809-88	KNOB, volume control	93*-DM/P	--	--	--
30	71814-91	KNOB, function switch	93*-DM/P	--	--	--
31	72055-94	CONNECTOR, 2-way (2)	94*-DM/P	--	--	--
32	72059-89A	PLUG, weather	93-DM/P	--	--	--
	72060-94	PLUG, weather	94*-DM/P	--	--	--
33	72191-94	TERMINAL, socket (3)	94*-DM/P	--	--	--
34	76175-86	CLIP, double end (8)	93*-DM/P	--	--	--
35	76303-89	SPEAKER HOUSING, rear - left	93*-DM/P	--	--	--
	76304-91	SPEAKER HOUSING, rear - right	93*-DM/P	--	--	--
36	76307-89	SPEAKER GRILLE, rear (2)	93*-DM/P	--	--	--
37	76315-91	FACE PLATE	93-DM/P	--	--	--
38	77161-94	REAR SPEAKER CONTROL	94*-DM/P	--	--	--
39	90493-83	HOLE PLUG (Japan only)	93*-DM/P	--	--	--
40	90844-80	ACORN NUT (2)	93*-DM/P	--	--	--

FLT MODELS
 FLHTC DJ
 FLTC-U DM
 FLHTC-U DP
 FLHS FA
 FLHR FD

FXR MODELS
 FXR EA
 FXRS-SP EG
 FXLR EL
 FXRS-CON EM

SOFTAIL MODELS
 FLSTC BJ
 FXSTC BK
 FXSTS BL
 FLSTF BM
 FLSTN BN

DYNA MODELS
 FXDL GD
 FXDWG GE
 FXDS-CON GG

SHOCK ABSORBERS - AIR & HYDRAULIC

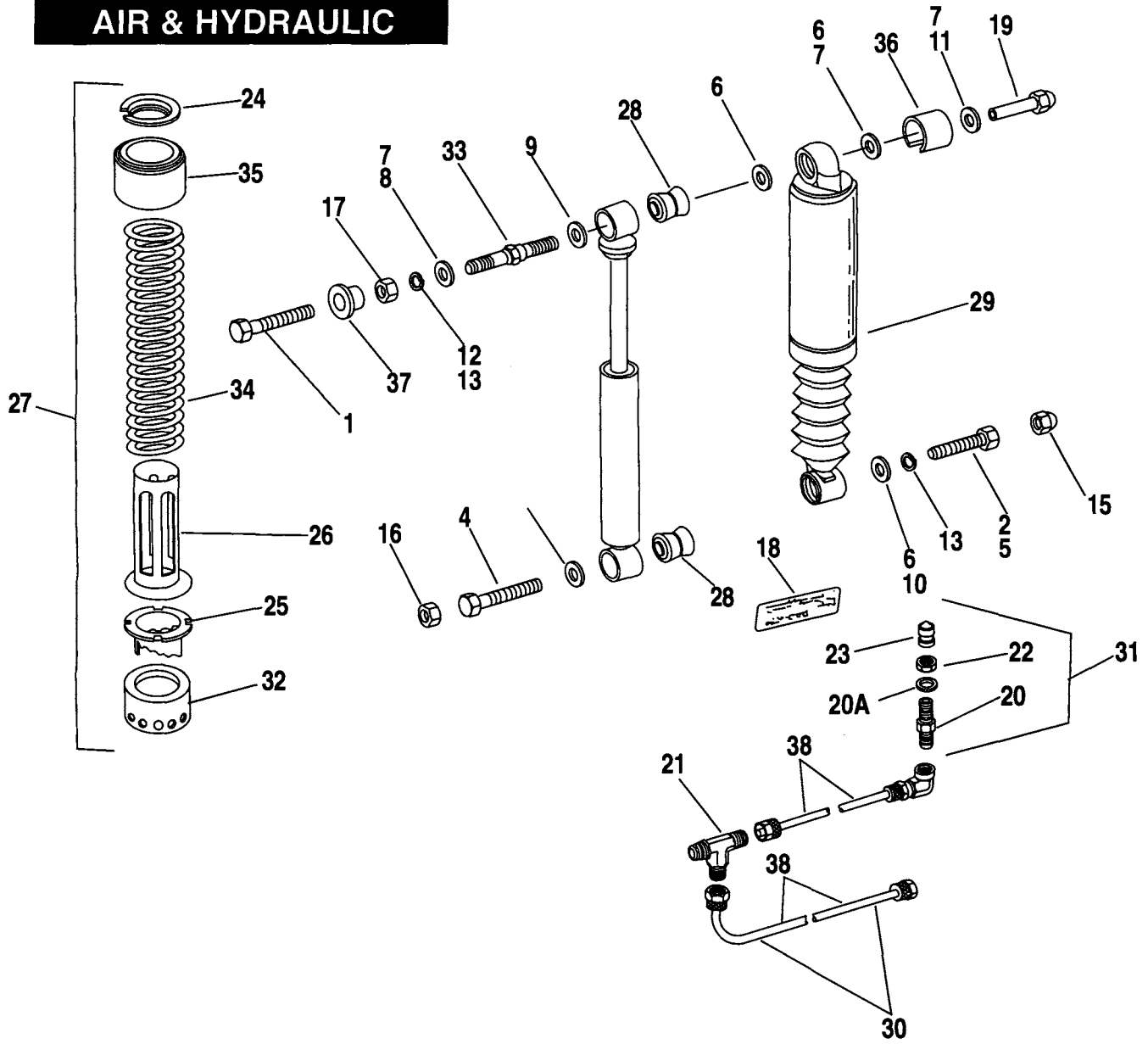

SHOCK ABSORBERS - AIR & HYDRAULIC

FB31

INDEX NO.	PART NO.	DESCRIPTION	FLT MODELS	FXR MODELS	SOFTAIL MODELS	DYNA MODELS
1	2879W	BOLT (2)	93*-ALL	93*-EA/G/M	--	--
	2906	BOLT (2)	--	93*-EL	--	--
2	3607	SCREW (2)	93*-ALL	--	--	--
	3891	SCREW (2)	--	--	--	94*-GG
4	3958	BOLT (2)	--	--	--	93*-GD/E
5	4081	BOLT (2)	--	93*-ALL	--	--
6	6012	WASHER (6; 2-Dyna)	93*-ALL	--	--	93*-GD/E
7	6113	WASHER (6)	--	--	--	93*-ALL
8	6127	WASHER (2)	93*-ALL	--	--	--
9	6530	WASHER (2)	--	93*-ALL	--	--
10	6718	WASHER (2)	--	93*-ALL	--	--
11	6738	WASHER (2)	--	93*-ALL	--	--
12	7038	LOCKWASHER (2)	--	93*-ALL	--	--
13	7068	LOCKWASHER (2)	93*-ALL	93*-ALL	--	93*-ALL
15	7554	ACORN NUT (4;2-GD)	--	--	--	93*-ALL
16	7812W	LOCKNUT (2)	--	--	--	94*-GG
16	7824	LOCKNUT (2)	--	93*-ALL	--	--
17	7845	LOCKNUT (2)	--	--	--	93*-ALL
18	14112-88	DECAL, air suspension	93*-ALL	--	--	--
19	54309-87	SCREW, int. thd. (2)	--	93*-ALL	--	--
	54312-91	SCREW, int. thd. (2)	93*-ALL	--	--	--
20	54317-85	VALVE, w/# 23	93*-ALL	--	--	--
20A	54319-85	WASHER	93*-ALL	--	--	--
21	54320-93	TEE FITTING, male	93*-ALL	--	--	--
22	54321-85	NUT	93*-ALL	--	--	--
23	54323-85	VALVE CAP	93*-ALL	--	--	--
24	54473-79	SPRING SEAT (2)	--	93*-ALL	--	93*-ALL
25	54474-79	ADJUSTER, spring (2)	--	93*-ALL	--	93*-ALL
26	54475-79	GUIDE, spring (2)	--	93*-ALL	--	93*-ALL
27	54502-87	SHOCK ABSORBER, complete (2)	--	93*-EA/L	--	--
	54506-87	SHOCK ABSORBER, complete (2)	--	93*-EG/M	--	--
	54512-90A	SHOCK ABSORBER, complete (2)	--	--	--	93*-GD/E
	54577-94	SHOCK ABSORBER, complete (2)	--	--	--	93*-GG
28	54523-82	BUSHING (4)	--	93*-ALL	--	--
	54556-84	BUSHING (4)	--	--	--	93*-ALL
29	54531-92	SHOCK ABSORBER, complete (2)	93*-ALL	--	--	--
30	54533-93	TUBE, air interconnect	93*-ALL	--	--	--
31	54536-93	VALVE ASM. w/ hose	93*-ALL	--	--	--
32	54569-84	CAM SLEEVE (2)	--	--	--	93*-GD/E
33	54557-90	BOLT, shock mount (2)	--	--	--	93*-ALL
34	54585-87	SPRING (chrome) (2)	--	93*-EA/L	--	--
	54586-87	SPRING (chrome) (2)	--	93*-EG/M	--	--
35	54701-82	COVER, upper (chrome)	--	93*-ALL	--	--
	54710-84	COVER, upper (chrome)	--	--	--	93*-ALL
36	54705-81	COVER, stud (chrome)	--	93*-ALL	--	--
	54708-65A	COVER, shock bolt (2)	--	--	--	93*-ALL
37	67622-94	SPACER (2)	94*-FD	--	--	--

NOTE: Hose is sold only in bulk length under the following part number. Cut to length.

37	54324-85	HOSE, 5/64 I.D. x 1/8 O.D. (25 ft. lg.)(black)	93*-ALL	--	--	--
----	----------	--	---------	----	----	----

FLT MODELS
 FLHTC
 FLTC-U
 FLHTC-U
 FLHS
 FLHR

FXR MODELS
 DJ
 DM
 DP
 FA
 FD
 FXR
 FXRS-SP
 FXLR
 FXRS-CON
 EA
 EG
 EL
 EM

SOFTAIL MODELS
 FLSTC
 FXSTC
 FXSTS
 FLSTF
 FLSTN
 BJ
 BK
 BL
 BM
 BN

DYNA MODELS
 FXDL
 FXDWG
 FXDS-CON
 GD
 GE
 GG

SHOCK ABSORBERS — SOFTAIL

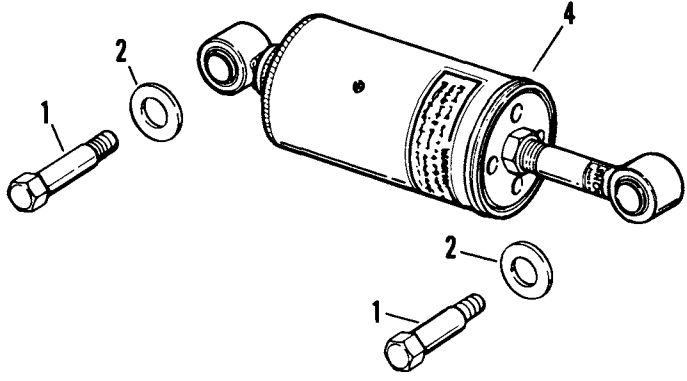

SHOCK ABSORBERS - SOFTAIL MODELS

FB31A

INDEX NO.	PART NO.	DESCRIPTION	FLT MODELS	FXR MODELS	SOFTAIL MODELS	DYNA MODELS
1	4074	BOLT (4)	--	--	93*-ALL	--
2	6724	WASHER (4)	--	--	93*-ALL	--
4	54508-89A	SHOCK ABSORBER, complete (2)	--	--	93*-ALL	--

FLT MODELS

FLHTC DJ
 FLTC-U DM
 FLHTC-U DP
 FLHS FA
 FLHR FD

FXR MODELS

FXR EA
 FXRS-SP EG
 FXLR EL
 FXRS-CON EM

SOFTAIL MODELS

FLSTC BJ
 FXSTC BK
 FXSTS BL
 FLSTF BM
 FLSTN BN

DYNA MODELS

FXDL GD
 FXDWG GE
 FXDS-CON GG

HANDLEBAR

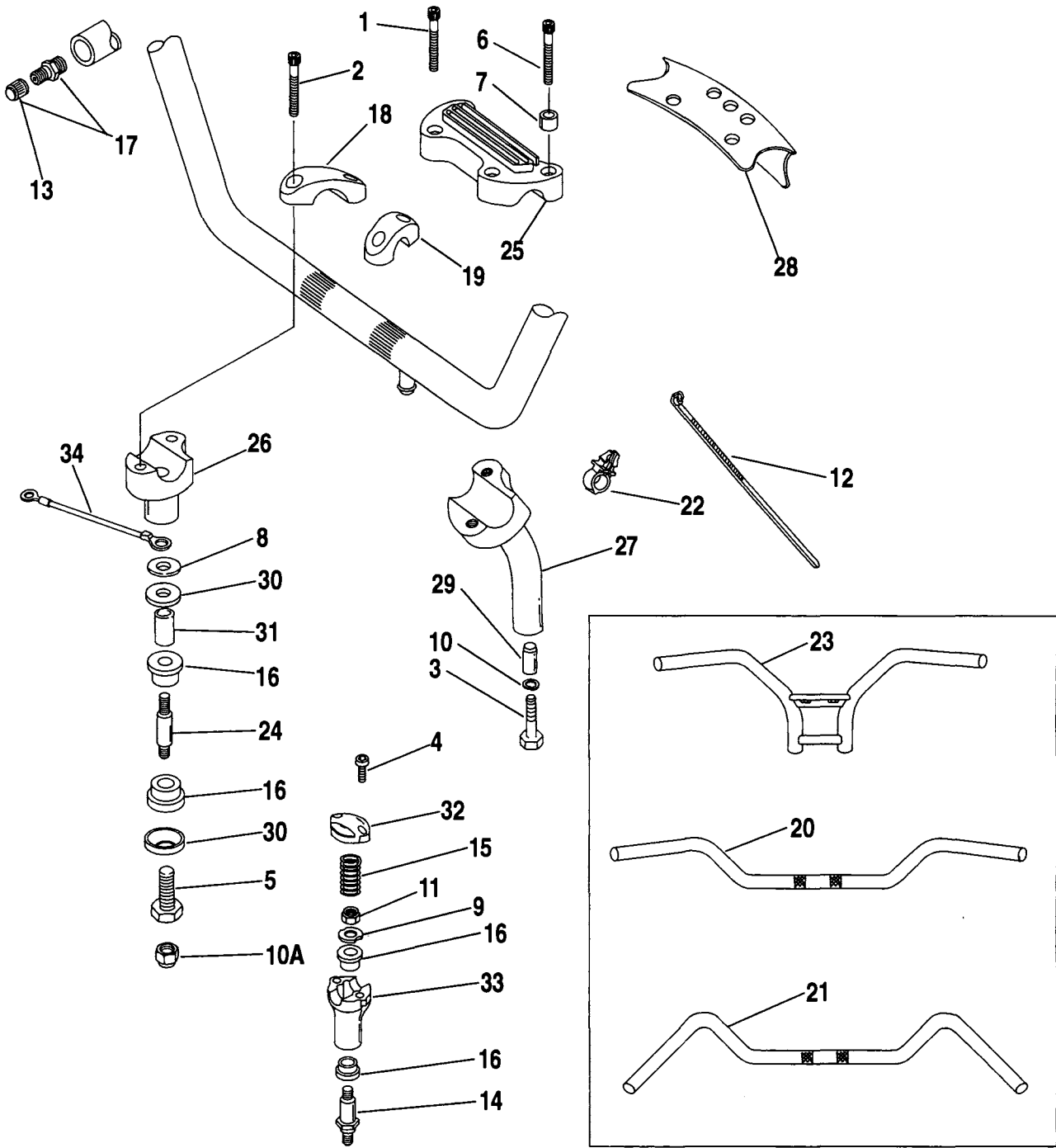

INDEX NO.	PART NO.	DESCRIPTION	FLT MODELS	FXR MODELS	SOFTAIL MODELS	DYNA MODELS
1	853A	SCREW (2)	--	93*-EG/M	--	94*-GG
2	3210A	SCREW (4)	93*-ALL	--	--	--
3	3450	BOLT (2)	--	--	93*-BK	--
	3471	BOLT (2)	--	93*-ALL	--	93*-ALL
4	3494A	SCREW (4)	--	--	93*-BL	--
5	3605	SCREW (2)	93*-ALL	--	--	--
6	4816A	SCREW (4;2-GG)	--	93*-EA/G/M	93*-BJ/M/N	93*-ALL
7	5736	SPACER (2)	--	93*-EG/M	--	94*-GG
8	6113	WASHER	93*-ALL	--	--	--
9	6753	WASHER	--	--	93*-ALL	--
10	7068	LOCKWASHER (2)	--	93*-ALL	93*-BK	93*-ALL
10A	7739	LOCKNUT (4)	93*-ALL	93*-EA/G/M	--	--
11	7768W	LOCKNUT (2)	--	--	93*-ALL	--
12	10065	CABLE STRAP (2)	--	--	93*-BL	--
13	41123-79	VALVE CAP	93-ALL; 94*-DJ/M/P	93*-EC/G/M	--	--
14	45544-88	STUD, rigid fork leg (2)	--	--	93*-BL	--
15	46059-90	SPRING	--	--	93*-BL	--
16	53156-86	BUSHING (rubber) (4)	--	93*-ALL	93*-ALL	93*-ALL
	56161-83A	BUSHING (rubber) (4)	93*-ALL	--	--	--
17	54316-83A	VALVE STEM ASSEMBLY	93*-ALL	93*-EG/M	--	--
18	55917-79	CLAMP, upper - right	93*-ALL	--	--	--
19	55918-79	CLAMP, upper - left	93*-ALL	--	--	--
20	55919-82	HANDLEBAR	94*-FD	--	93*-BM/N	--
	56569-86	HANDLEBAR	--	--	93*-BJ	--
21	55920-83B	HANDLEBAR	93-ALL; 94*-DJ/M/P	--	--	--
	55934-92	HANDLEBAR	--	93*-EM	--	--
	55937-92	HANDLEBAR	--	93*-EG	--	--
	56079-93	HANDLEBAR, factory ape hanger	--	--	--	93*-GE
	56081-82	HANDLEBAR	--	93*-EA	93*-BK	93*-GD/G
	56093-88	HANDLEBAR	--	--	93*-BL	--
22	56073-83	RETAINER (4)	94*-FD	93*-EA	93*-ALL	--

FLT MODELS

FLHTC DJ
 FLTC-U DM
 FLHTC-U DP
 FLHS FA
 FLHR FD

FXR MODELS

FXR EA
 FXRS-SP EG
 FXLR EL
 FXRS-CON EM

SOFTAIL MODELS

FLSTC BJ
 FXSTC BK
 FXSTS BL
 FLSTF BM
 FLSTN BN

DYNA MODELS

FXDL GD
 FXDWG GE
 FXDS-CON GG

HANDLEBAR

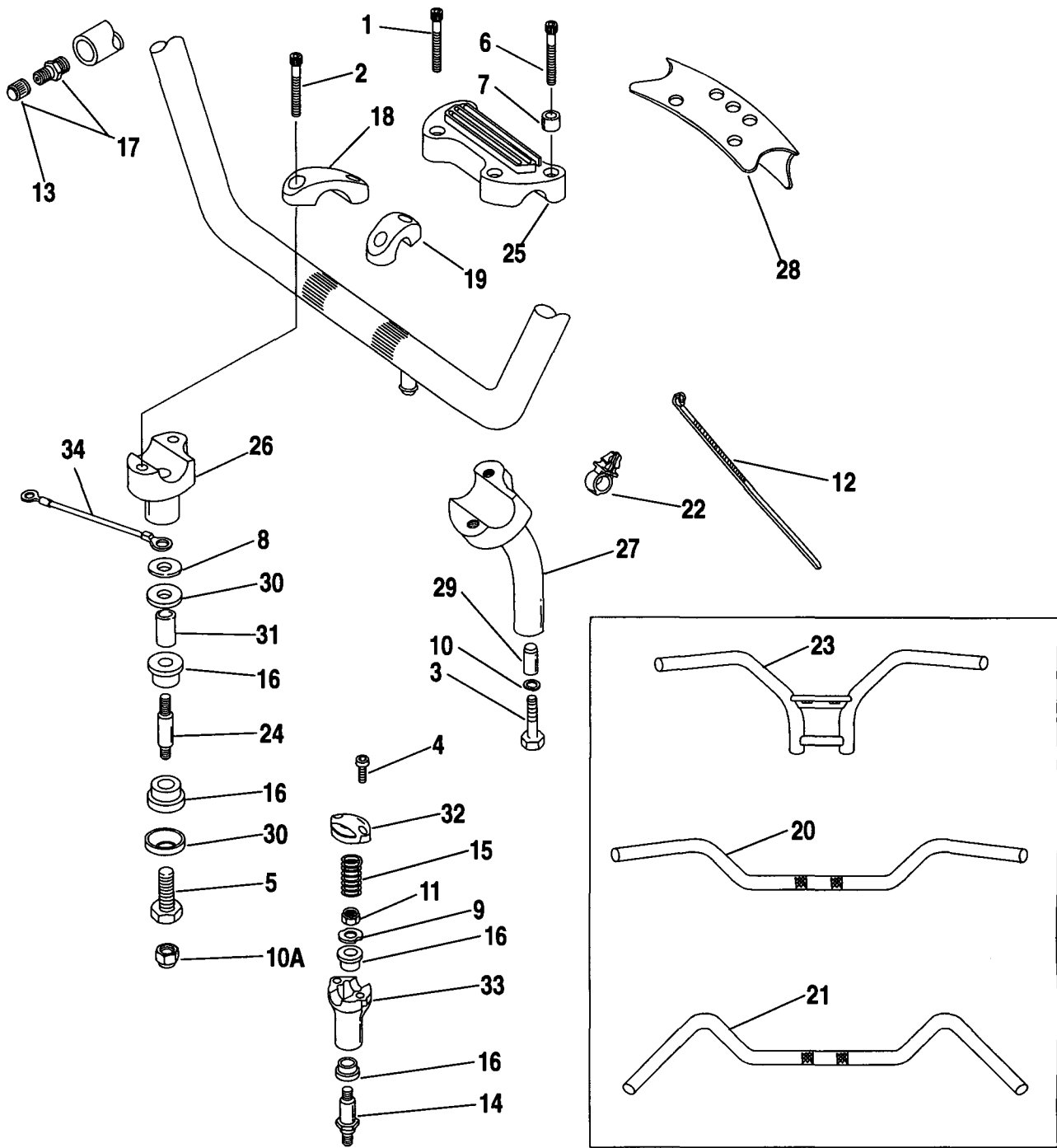

INDEX NO.	PART NO.	DESCRIPTION	FLT MODELS	FXR MODELS	SOFTAIL MODELS	DYNA MODELS
23	56084-87A	HANDLEBAR	--	93*-EL	--	--
24	56105-84	STUD (2)	--	--	93*-BJ/M/N	--
25	56115-79B	CLAMP, upper	--	93*-EA/G/M	--	94*-GG
	56119-77A	CLAMP, upper	--	--	93*-BK	93*-GD
	56567-86A	CLAMP, upper (chrome)	--	--	93*-BJ/M/N	93*-GE
26	56116-82A	CLAMP, lower - right (left - EA)	--	93*-EA/G/M	--	93*-GD/G
	56117-82A	CLAMP, lower - left (right - EA)	--	93*-EA/G/M	--	93*-GD/G
	56140-84A	CLAMP, lower - right	93-DM,FA; 94*-ALL	--	--	--
	56141-84A	CLAMP, lower - left	93-DM,FA; 94*-ALL	--	--	--
	56149-88A	CLAMP, lower - right	93-DJ/P	--	--	--
	56151-88A	CLAMP, lower - left	93-DJ/P	--	--	--
	56541-86A	CLAMP, lower - left (chrome)	--	--	93*-BJ/M/N	93*-GE
	56542-86A	CLAMP, lower - right (chrome)	--	--	93*-BJ/M/N	93*-GE
27	56122-77	CLAMP, lower - left	--	--	93*-BK	--
	56124-77	CLAMP, lower - right	--	--	93*-BK	--
28	56148-92	COVER	--	93*-EL	--	--
29	56153-73	SPACER (2)	--	93*-ALL	93*-BK	93*-ALL
30	56159-73	CUP WASHER (4)	93*-ALL	93*-ALL	93*-ALL	93*-ALL
31	56163-93	SPACER (2)	93*-ALL	--	--	--
32	56538-88	CLAMP (2)	--	--	93*-BL	--
33	56540-88	RISER (2)	--	--	93*-BL	--
34	70142-93	CABLE, ground	93-ALL	--	--	--
	70191-73A	CABLE, ground	--	93*-ALL	93*-BK	--
	70197-86	CABLE, ground	--	--	93*-BJ/M/N	--
H-D INTERNATIONAL ONLY						
4	3531A	SCREW (4) (HDI only)	--	--	93*-BL	--

FLT MODELS

FLHTC DJ
 FLTC-U DM
 FLHTC-U DP
 FLHS FA
 FLHR FD

FXR MODELS

FXR EA
 FXRS-SP EG
 FXLR EL
 FXRS-CON EM

SOFTAIL MODELS

FLSTC BJ
 FXSTC BK
 FXSTS BL
 FLSTF BM
 FLSTN BN

DYNA MODELS

FXDL GD
 FXDWG GE
 FXDS-CON GG

THROTTLE CONTROL

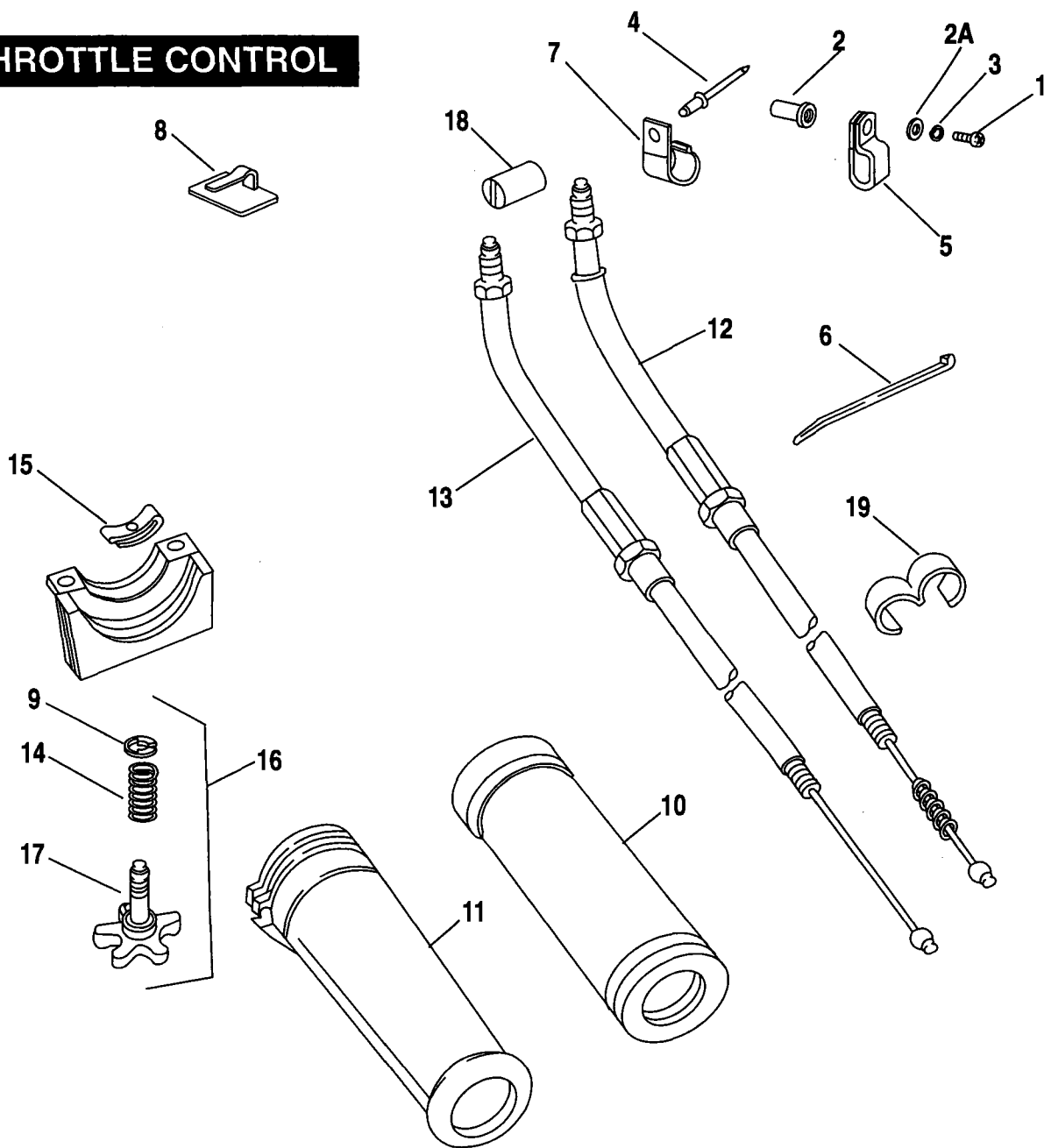

THROTTLE CONTROL

FB33

INDEX NO.	PART NO.	DESCRIPTION	FLT MODELS	FXR MODELS	SOFTAIL MODELS	DYNA MODELS
1	933	SCREW	94*-DJ/P;FD	--	--	--
	2882W	SCREW	--	93*-EG	--	--
2	5207	WELLNUT	94*-DJ/P;FD	--	--	--
2A	6047	WASHER	94*-DJ/P;FD	--	--	--
	6702	WASHER	--	93*-EG	--	--
3	7041	LOCKWASHER	--	93*-EG	--	--
4	8483	RIVET	93*-ALL	--	--	--
5	9988	CLAMP, throttle cable	--	93*-ALL	93*-BL	--
	10003	CLAMP	93-ALL	--	--	--
6	10006	CABLE STRAP	--	--	93*-ALL	--
	10007	CABLE STRAP	93*-ALL	--	--	--
	10081	CABLE STRAP, double loop	--	--	--	93*-ALL
7	10092	CLAMP	93*-ALL	--	--	--
8	10103	CLIP, throttle cables	--	--	--	93*-ALL
9	11155	RETAINING RING	93*-ALL	93*-ALL	93*-ALL	93*-ALL
10	55915-94	GRIP, left	93-ALL; 94*-DJ/M/P	93*-EG/M	--	--
	56206-94	GRIP, left	94*-FD	93*-EA/L	93*-ALL	93*-ALL
11	56220-94	GRIP & SLEEVE, throttle - right	93*-ALL	93*-ALL	93*-ALL	93*-ALL
12	56305-90	IDLE CONTROL	--	--	93*-BL	--
	56328-90	IDLE CONTROL	93*-DJ,FA	--	--	--
	56342-90	IDLE CONTROL	--	93*-ALL	93*-BJ/K/ M/N	--
13	56355-92	IDLE CONTROL	--	--	--	93*-ALL
	56306-90	THROTTLE CONTROL	--	--	93*-BL	--
	56327-90	THROTTLE CONTROL	93*-DJ,FA	--	--	--
	56343-90	THROTTLE CONTROL	--	93*-ALL	93*-BJ/K/ M/N	--
	56356-92	THROTTLE CONTROL	--	--	--	93*-ALL
14	56394-74	SPRING, adjusting screw	93*-DJ,FA	93*-ALL	93*-ALL	93*-ALL
15	56396-74A	FRICTION SPRING, throttle	93*-DJ,FA	93*-ALL	93*-ALL	93*-ALL
16	56397-74C	ADJUSTING SCREW KIT, w/ #3, 9 & 12	93*-DJ,FA	93*-ALL	93*-ALL	93*-ALL
17	56402-83A	ADJUSTING SCREW	93*-DJ,FA	93*-ALL	93*-ALL	93*-ALL
18	56508-76	FERRULE, control wire (2)	93*-ALL	93*-ALL	93*-ALL	93*-ALL
19	70504-81	CLIP, throttle cables	--	93*-ALL	93*-ALL	93*-ALL

FLT MODELS

FLHTC DJ
 FLTC-U DM
 FLHTC-U DP
 FLHS FA
 FLHR FD

FXR MODELS

FXR EA
 FXRS-SP EG
 FXLR EL
 FXRS-CON EM

SOFTAIL MODELS

FLSTC BJ
 FXSTC BK
 FXSTS BL
 FLSTF BM
 FLSTN BN

DYNA MODELS

FXDL GD
 FXDWG GE
 FXDS-CON GG

CRUISE CONTROL

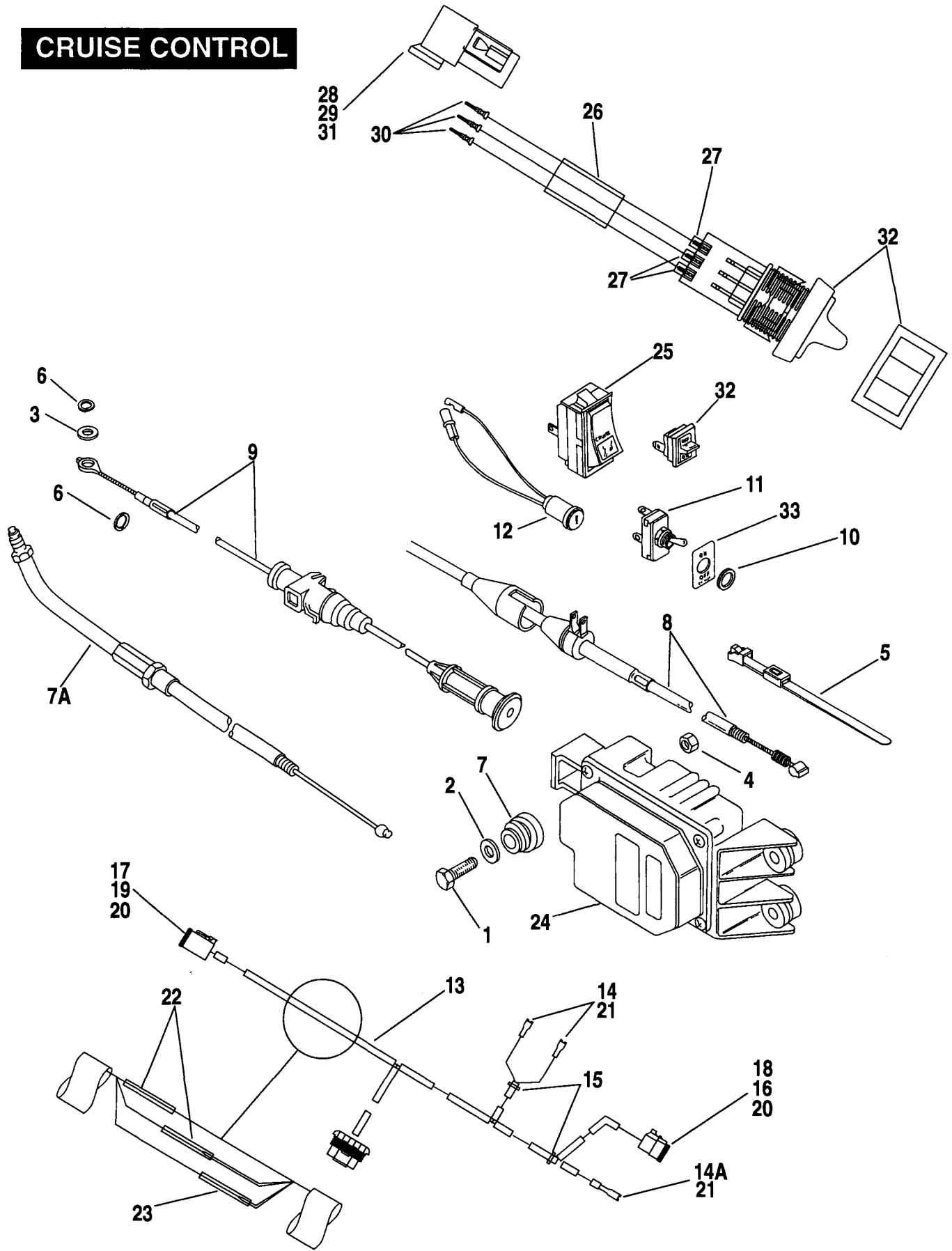

INDEX NO.	PART NO.	DESCRIPTION	FLT MODELS	FXR MODELS	SOFTAIL MODELS	DYNA MODELS
1	2551W	SCREW (3)	93*-DM/P	--	--	--
2	6703	WASHER (3)	93*-DM/P	--	--	--
3	6716	WASHER	93*-DM/P	--	--	--
4	7716	NUT, flange	93*-DM/P	--	--	--
5	10133	T-CLIP, cable to backbone	94*-DM/P	--	--	--
6	11193	RETAINING RING (2)	93*-DM/P	--	--	--
7	11478	GROMMET (3)	93*-DM/P	--	--	--
7A	56327-90	THROTTLE CONTROL	93*-DM/P	--	--	--
8	56351-90	IDLE CONTROL	93*-DM/P	--	--	--
9	56354-93	STEPPER CABLE	93*-DM/P	--	--	--
10	67846-70	NUT, toggle switch	93*-DM	--	--	--
11	67858-89	SWITCH, cruise control	93*-DM	--	--	--
12	68536-75	INDICATOR LAMP	93*-DM	--	--	--
	68688-89	LAMP ASSEMBLY, cruise indicator	93*-DM	--	--	--
	70141-93	HARNESS, cruise control (not illustrated)	93*-DM/P	--	--	--
13	70141-94	HARNESS, cruise control includes the following:	94*-DM/P	--	--	--
14	9930	TERMINAL, female spade - 3/16 slot	94*-DM/P	--	--	--
14A	9937	TERMINAL, 1/4" female 14-18 ga.	94*-DM/P	--	--	--
15	10065	CABLE STRAP (2)	94*-DM/P	--	--	--
16	72113-94BK	PLUG, 3-way socket	94*-DM/P	--	--	--
17	72116-94BK	PLUG, 6-way socket*	94*-DM/P	--	--	--
18	72153-94	SOCKET LOCK, sec. 3-way	94*-DM/P	--	--	--
19	72156-94	SOCKET LOCK, sec. 6-way	94*-DM/P	--	--	--
20	72191-94	TERMINAL, socket (9)	94*-DM/P	--	--	--
21	72249-94	HEAT SHRINK TUBE, 0.3 x 1" (3)	94*-DM/P	--	--	--
22	72266-94	HEAT SHRINK TUBE, dual wall, 0.45 x 2" (2)	94*-DM/P	--	--	--
23	72268-94	HEAT SHRINK TUBE, dual wall, 0.7 x 2" (2)	94*-DM/P	--	--	--
24	70958-93	STEPPER MOTOR	93*-DM/P	--	--	--
25	71513-89	SWITCH, cruise control	93*-DP	--	--	--
	71585-93	CABLE ASM., cruise set switch (not illustrated)	93*-DM/P	--	--	--
26	71585-94	CABLE ASM., cruise set switch includes the following:	94*-DM/P	--	--	--
27	9904	TERMINAL, female spade - 1/8 slot (3)	94*-DM/P	--	--	--
28	72103-94BK	RECEPTACLE, 3-way pin	94*-DM/P	--	--	--
29	72143-94	PIN LOCK, sec. 3-way	94*-DM/P	--	--	--
30	72190-94	TERMINAL, pin (3)	94*-DM/P	--	--	--
31	72199-94	ATTACHMENT CLIP	94*-DM/P	--	--	--
32	77101-90A	HANDLEBAR SWITCH, cruise set/resume	94*-DM/P	--	--	--
32	77101-90A	HANDLEBAR SWITCH, cruise set/resume	93*-DM/P	--	--	--
33	77113-89	LABEL, cruise	93*-DM	--	--	--

FLT MODELS

FLHTC DJ
 FLTC-U DM
 FLHTC-U DP
 FLHS FA
 FLHR FD

FXR MODELS

FXR EA
 FXRS-SP EG
 FXLR EL
 FXRS-CON EM

SOFTAIL MODELS

FLSTC BJ
 FXSTC BK
 FXSTS BL
 FLSTF BM
 FLSTN BN

DYNA MODELS

FXDL GD
 FXDWG GE
 FXDS-CON GG

WINDSHIELD, FAIRING & LAMPS - FLTC

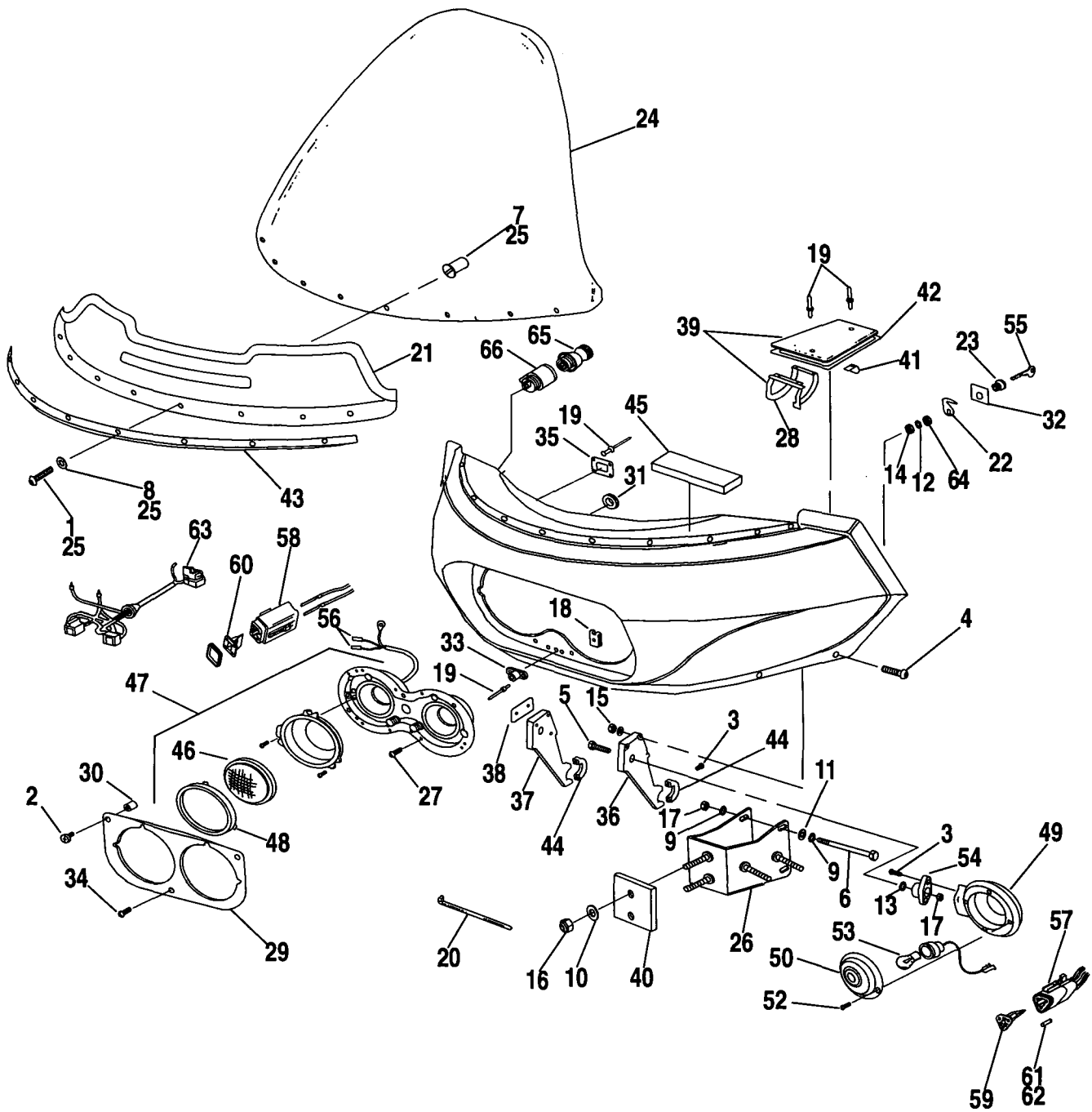

INDEX NO.	PART NO.	DESCRIPTION	FLT MODELS	FXR MODELS	SOFTAIL MODELS	DYNA MODELS
NOTE: REFER TO DEALER ACESORY GUIDE FOR PAINTED PART NUMBERS.						
1	933	SCREW (7)	93*-DM	--	--	--
2	2504	SCREW (2)	93*-DM	--	--	--
3	2647B	SCREW (8)	93*-DM	--	--	--
4	2648	SCREW (4)	93*-DM	--	--	--
5	4411	BOLT (2)	93*-DM	--	--	--
6	4435W	BOLT (2)	93*-DM	--	--	--
7	5207	WELL NUT (7)	93*-DM	--	--	--
8	6053	WASHER (7)	93*-DM	--	--	--
9	6701	WASHER (4)	93*-DM	--	--	--
10	6702	WASHER (2)	93*-DM	--	--	--
11	7101	LOCKWASHER	93-DM	--	--	--
12	7128	LOCKWASHER (2)	93*-DM	--	--	--
13	7130W	LOCKWASHER (4)	93*-DM	--	--	--
14	7586	NUT (2)	93*-DM	--	--	--
15	7686	LOCKNUT (4)	93*-DM	--	--	--
16	7725	LOCKNUT (2)	E93-DM	--	--	--
	7739	LOCKNUT (2)	L93*-DM	--	--	--
17	7775	LOCKNUT (4)	93*-DM	--	--	--
18	8107	CLIP NUT, headlamp mounting (4)	93*-DM	--	--	--
19	8692	POP RIVET (black aluminum) (22)	93*-DM	--	--	--
20	10006	CABLE STRAP (2)	93*-DM	--	--	--
	10065	CABLE STRAP (2)	93*-DM	--	--	--
21	14224-89	DECAL, "Harley-Davidson" (silver)	93*-DM	--	--	--
	53575-93	LOCK SET, complete vehicle	93*-DM	--	--	--
22	53583-92	CAM HOOK (2)	93*-DM	--	--	--
23	53584-92	LOCK, fairing (2)	93*-DM	--	--	--
24	58009-89A	WINDSHIELD ASSEMBLY, 2" tall. w/ #1, 7, 8, 21, & 43	93*-DM	--	--	--
	58016-89A	WINDSHIELD ASSEMBLY std. w/ #1, 7, 8, 21 & 43	93*-DM	--	--	--
	58453-89A	WINDSHIELD ASSEMBLY 3" short w/ #1, 7, 8, 21, & 43	93*-DM	--	--	--
25	58031-80	WINDSHIELD MOUNTING KIT, w/ #1, 7, & 8	93*-DM	--	--	--
26	58400-80	BRACKET, mounting - upper	93-DM	--	--	--
	58400-94	BRACKET, mounting - upper	94*-DM	--	--	--
27	58402-80	SCREW, headlamp mounting (4)	93*-DM	--	--	--
28	58459-80	HINGE, cover (2)	93*-DM	--	--	--
29	58460-80	TRIM PLATE, headlamp	93*-DM	--	--	--
30	58461-80	SPACER (2)	93*-DM	--	--	--
31	58462-89	GROMMET, slit	93-DM	--	--	--
	58467-94	GROMMET, split	94*-DM	--	--	--
	58468-94	GROMMET, split	94*-DM	--	--	--
32	58466-80	WASHER PLATE (2)	93*-DM	--	--	--
33	58473-80	MOUNTING BRACKET (3)	93*-DM	--	--	--
34	58477-80	SCREW, headlamp trim plate	93*-DM	--	--	--

FLT MODELS

FLHTC DJ
 FLTC-U DM
 FLHTC-U DP
 FLHS FA
 FLHR FD

FXR MODELS

FXR EA
 FXRS-SP EG
 FXLR EL
 FXRS-CON EM

SOFTAIL MODELS

FLSTC BJ
 FXSTC BK
 FXSTS BL
 FLSTF BM
 FLSTN BN

DYNA MODELS

FXDL GD
 FXDWG GE
 FXDS-CON GG

WINDSHIELD, FAIRING & LAMPS - FLTC

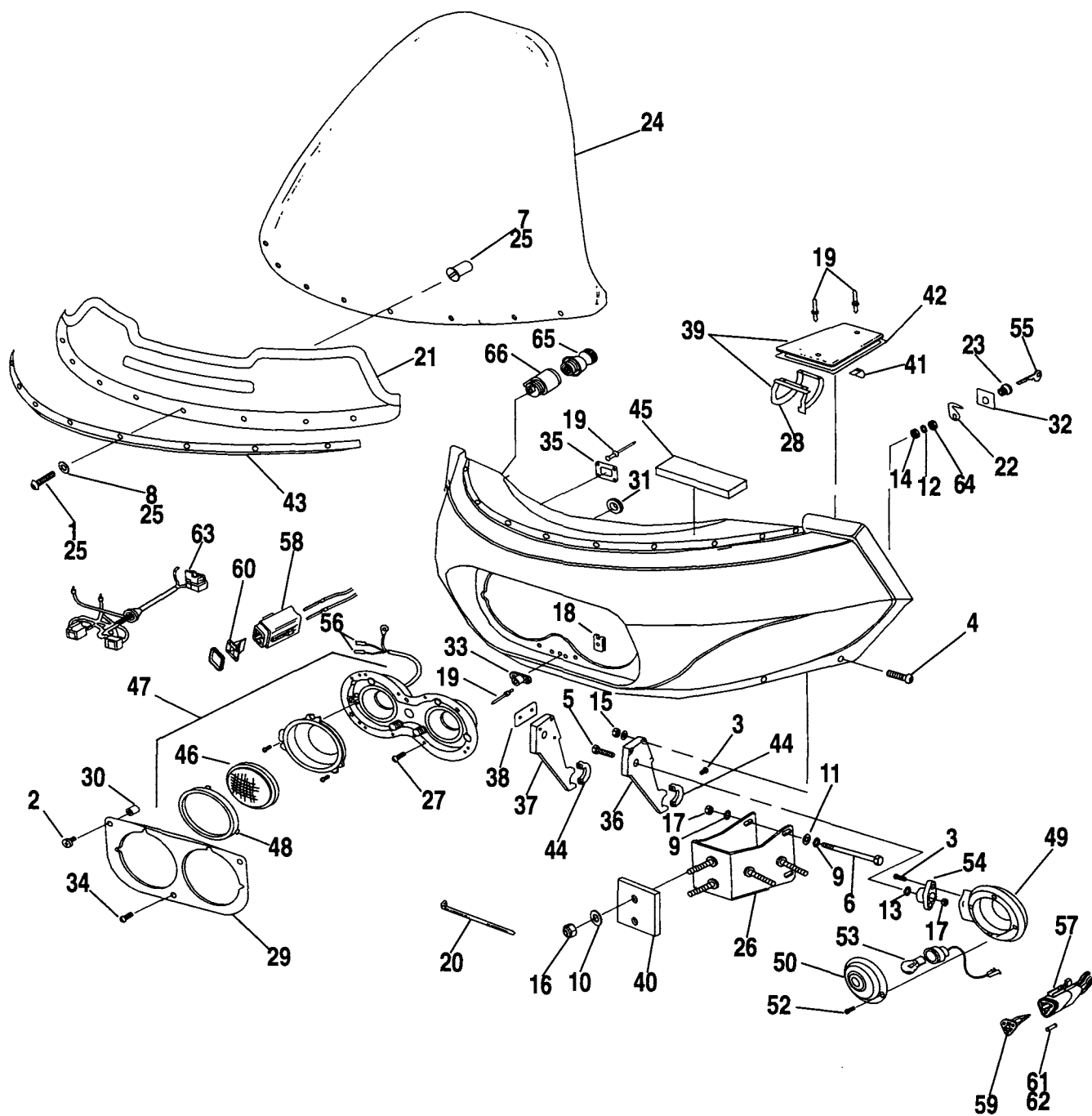

INDEX NO.	PART NO.	DESCRIPTION	FLT MODELS	FXR MODELS	SOFTAIL MODELS	DYNA MODELS
35	58482-86	MOUNTING PLATE	93*-DM	--	--	--
36	58484-89	SUPPORT BRACKET, left	93*-DM	--	--	--
37	58486-89	SUPPORT BRACKET, right	93*-DM	--	--	--
38	58488-84	GASKET (2)	93*-DM	--	--	--
39	58712-79A	COVER, right (black)	93*-DM	--	--	--
	58713-79A	COVER, left (black)	93*-DM	--	--	--
40	58714-79	PAD (rubber)	93*-DM	--	--	--
41	58715-79	LATCH, cover (2)	93*-DM	--	--	--
42	58716-79	GASKET, cover (2)	93*-DM	--	--	--
43	58717-79	FOAM TAPE, windshield	93*-DM	--	--	--
44	58826-89	CLAMP, mounting bracket (2)	93*-DM	--	--	--
45	66104-84	PAD (3)	93*-DM	--	--	--
46	67692-92	SEALED BEAM UNIT -5-3/4" (2)	93*-DM	--	--	--
47	67775-81B	HEADLAMP ASM. w/ housing -5-3/4"	93-DM	--	--	--
	67775-94	HEADLAMP ASM. w/ housing -5-3/4"	94*-DM	--	--	--
48	67746-85	RETAINING RING (2)	93*-DM	--	--	--
49	68398-88	LAMP w/ WIRE (2)	93-DM	--	--	--
	68766-94	LAMP w/ WIRE (2)	94*-DM	--	--	--
50	68440-86	LENS, turn signals (amber) (2)	93*-DM	--	--	--
52	68452-86	SCREW (4)	93*-DM	--	--	--
53	68168-89	BULB, turn signal (2)	93*-DM	--	--	--
54	68519-68	MOUNTING BRACKET (2)	93*-DM	--	--	--
55	71452-91A	KEY (specify key code number)	93*-DM	--	--	--
56	72039-71	PIN, single socket (3)	93*-DM	--	--	--
57	72113-94BK	PLUG, 3-way socket, (2)	94*-DM	--	--	--
58	72114-94BK	PLUG, 4-way socket	94*-DM	--	--	--
59	72153-94	SOCKET LOCK, sec. 3-way (2)	94*-DM	--	--	--
60	72154-94	SOCKET LOCK, sec. 4-way	94*-DM	--	--	--
61	72191-94	TERMINAL, socket (9)	94*-DM	--	--	--
62	72195-94	SEAL PIN	94*-DM	--	--	--
63	72276-74	HOUSING, 12 pin	93-DM	--	--	--
64	84850-92	NUT, lock (2)	93*-DM	--	--	--
65	91808-89	ELEMENT, cigarette lighter	93*-DM	--	--	--
66	91812-89	SOCKET, cigarette lighter	93*-DM	--	--	--
H-D INTERNATIONAL ONLY						
	3546	SCREW (2)	93-DM	--	--	--
26	58398-84	BRACKET, mounting upper	93-DM	--	--	--
47	67754-92	HEADLAMP ASM. w/ housing -5-3/4"	93-DM	--	--	--
50	68505-90	LENS, turn signals (amber) (2) (HDI only)	93-DM	--	--	--
	68399-88A	LAMP w/ WIRE (2) (HDI only)	93-DM	--	--	--
53	68163-84	BULB, turn signal (2) (HDI only)	93-DM	--	--	--

FLT MODELS

FLHTC DJ
 FLTC-U DM
 FLHTC-U DP
 FLHS FA
 FLHR FD

FXR MODELS

FXR EA
 FXRS-SP EG
 FXLR EL
 FXRS-CON EM

SOFTAIL MODELS

FLSTC BJ
 FXSTC BK
 FXSTS BL
 FLSTF BM
 FLSTN BN

DYNA MODELS

FXDL GD
 FXDWG GE
 FXDS-CON GG

WINDSHIELD, FAIRING, HEADLAMP & NACELLE — FLHTC & FLHS

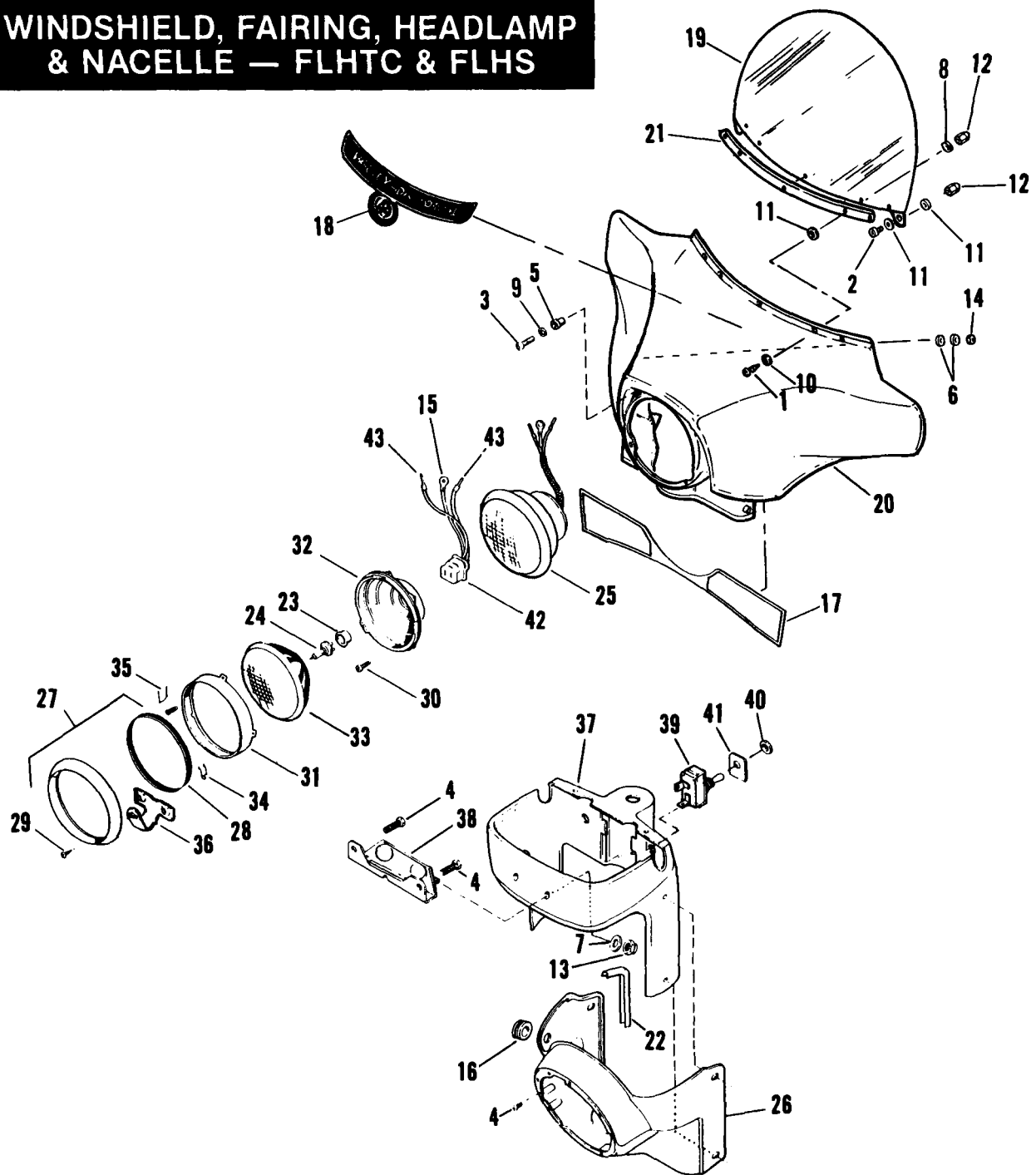

INDEX NO.	PART NO.	DESCRIPTION	FLT MODELS	FXR MODELS	SOFTAIL MODELS	DYNA MODELS
1	2432	SCREW (5)	93*-DJ/P	--	--	--
2	2726A	SCREW (2)	93*-DJ/P	--	--	--
3	2806	SCREW (5)	93*-DJ/P	--	--	--
4	5209	SCREW, hi-lo (9)	93-FA	--	--	--
5	5210	WELL NUT (5)	93*-DJ/P	--	--	--
6	6036	WASHER (8)	93*-DJ/P	--	--	--
7	6703	WASHER (2)	93*-FA	--	--	--
8	6717	WASHER (5)	93*-DJ/P	--	--	--
9	7008	WASHER (5)	93*-DJ/P	--	--	--
10	7017	WASHER (nylon) (5)	93*-DJ/P	--	--	--
11	7018	WASHER (9)	93*-DJ/P	--	--	--
12	7653	ACORN NUT (7)	93*-DJ/P	--	--	--
13	7682	LOCKNUT (2)	93-FA	--	--	--
14	7686	LOCKNUT (4)	93*-DJ/P	--	--	--
15	9857	TERMINAL, ring type	93-DJ/P, FA	--	--	--
16	11475	GROMMET, cable routing	93-FA	--	--	--
17	14128-86A	TRIM, lower fairing	93*-DJ/P	--	--	--
18	14217-89	DECAL "U.S.A." (silver)	93*-DP	--	--	--
	14250-90	DECAL "U.S.A." (gold)	93*-DP	--	--	--
	14414-94	DECAL "U.S.A." (burgundy)	94*-DP	--	--	--
19	58187-86	WINDOW, fairing	93*-DJ/P	--	--	--
20	58198-86	FAIRING, outer (prime)	93*-DJ/P	--	--	--
21	58247-86	CUSHION TAPE, outer fairing	93*-DJ/P	--	--	--
22	61117-86	TRIM, rubber	93-FA	--	--	--
23	67696-81	BOOT, halogen headlamp	93-DJ/P,FA; 94*-DJ/P	--	--	--
24	67697-81	BULB (Halogen H-4)	93-DJ/P,FA; 94*-DJ/P	--	--	--
25	67702-81A	HEADLAMP ASM. w/ housing-7"	93-DJ/P,FA; 94*-DJ/P	--	--	--
26	67704-93	NACELLE, headlamp	93-FA	--	--	--
27	67712-83	DOOR ASSEMBLY, w/ spring (chrome)	93-DJ/P,FA; 94*-DJ/P	--	--	--
28	67716-60A	GASKET, headlamp door	93-DJ/P,FA; 94*-DJ/P	--	--	--
29	67718-60A	SCREW, headlamp door	93-DJ/P,FA; 94*-DJ/P	--	--	--
30	67724-71	ADJUSTING SCREW, headlamp (2)	93-DJ/P,FA;; 94*-DJ/P	--	--	--
31	67726-71	RETAINING RING, headlamp	93-DJ/P,FA; 94*-DJ/P	--	--	--
32	67732-71A	MOUNTING RING, headlamp	93-DJ/P,FA; 94*-DJ/P	--	--	--
33	67755-81A	LENS, less bulb - w/ boot	93-DJ/P,FA; 94*-DJ/P	--	--	--

FLT MODELS

FLHTC
FLTC-U
FLHTC-U
FLHS
FLHR

DJ
DM
DP
FA
FD

FXR MODELS

FXR
FXRS-SP
FXLR
FXRS-CON

EA
EG
EL
EM

SOFTAIL MODELS

FLSTC
FXSTC
FXSTS
FLSTF
FLSTN

BJ
BK
BL
BM
BN

DYNA MODELS

FXDL
FXDWG
FXDS-CON

GD
GE
GG

WINDSHIELD, FAIRING, HEADLAMP & NACELLE — FLHTC & FLHS

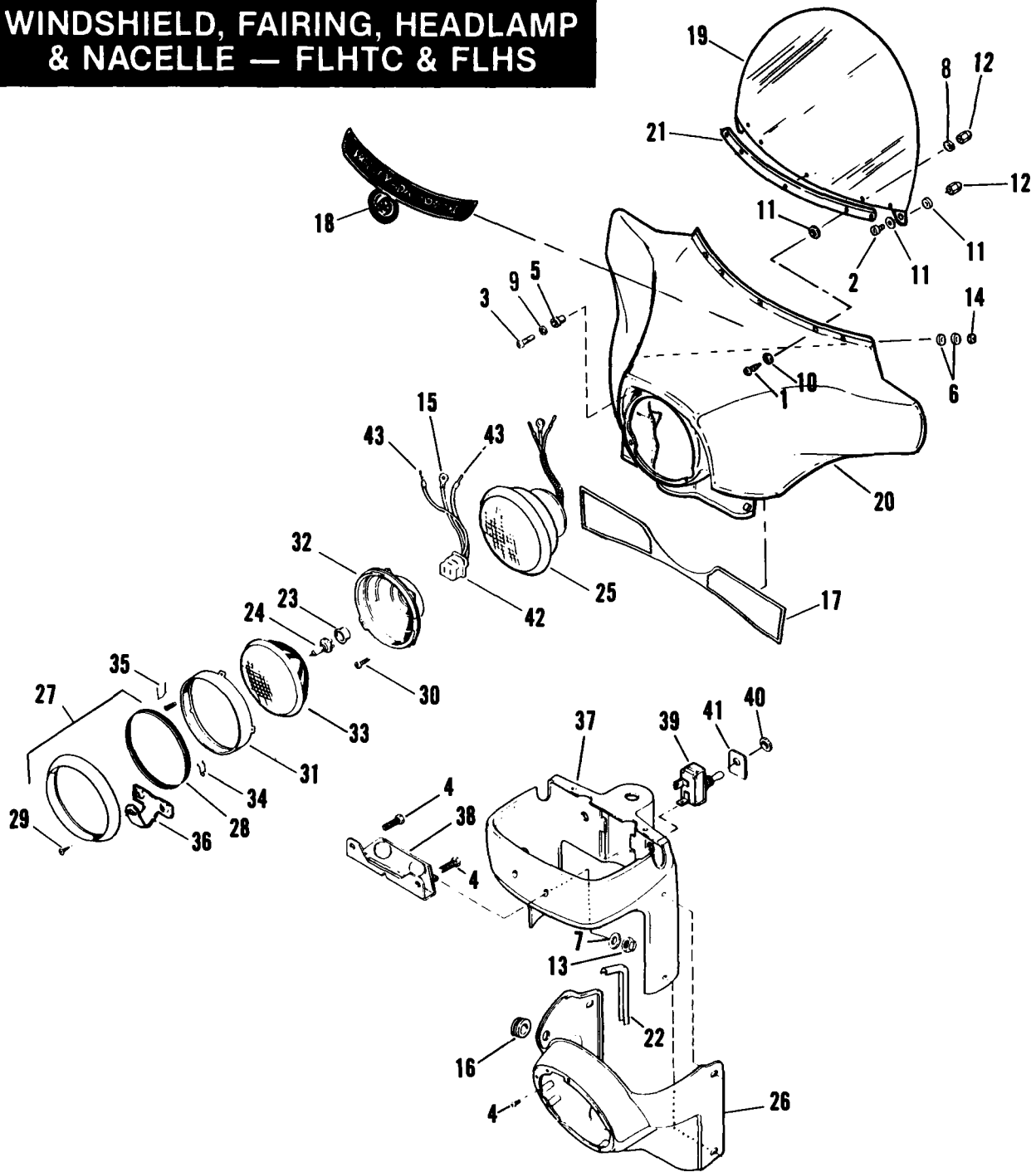

INDEX NO.	PART NO.	DESCRIPTION	FLT MODELS	FXR MODELS	SOFTAIL MODELS	DYNA MODELS
34	67778-60	TOP SPRING, headlamp door	93-DJ/P,FA; 94*-DJ/P	--	--	--
35	67780-60	BOTTOM SPRING, headlamp door (2)	93-DJ/PFA,; 94*-DJ/P	--	--	--
36	67782-60A	BRACKET, headlamp door (2)	93-DJ/P,FA; 94*-DJ/P	--	--	--
37	67800-93A	DASH PANEL SUPPORT	93-FA	--	--	--
38	67817-83	BRACKET, headlamp door	93-FA	--	--	--
39	67858-89	TOGGLE SWITCH, passing lamps	93-FA	--	--	--
40	67846-70	NUT, toggle switch (2)	93-FA	--	--	--
41	68619-83	LABEL, passing lamps	93-FA	--	--	--
42	68634-86	LAMP WIRING & CONNECTOR, headlamp	93-DJ/P,FA; 94*-DJ/P	--	--	--
43	72039-71	PIN, single socket	93-DJ/P,FA; 94*-DJ/P	--	--	--
		H-D INTERNATIONAL ONLY				
	14019-83	LABEL, passing & parking lamps (HDI only)	93-FA	--	--	--
	53438-92	BULB, position lamp (HDI only)	94*-DJ/P	--	--	--
25	67695-92	HEADLAMP ASM. w/ housing (HDI only)	93-DJ/P; FA	--	--	--
	67793-92	LENS ASM, w/ bulb & boot-R.H. Dip (HDI only)	94*-DJ/P	--	--	--
	67801-92	LENS ASM, w/ bulb & boot-L.H. Dip (HDI only)	94*-DJ/P	--	--	--
	67798-92	BOOT (HDI only)	94*-DJ/P	--	--	--
39	67858-89	TOGGLE SWITCH, parking lamps (HDI only)	93-FA	--	--	--
	68654-92	SOCKET, position lamp (HDI only)	94*-DJ/P	--	--	--

FLT MODELS

FLHTC DJ
FLTC-U DM
FLHTC-U DP
FLHS FA
FLHR FD

FXR MODELS

FXR EA
FXRS-SP EG
FXLR EL
FXRS-CON EM

SOFTAIL MODELS

FLSTC BJ
FXSTC BK
FXSTS BL
FLSTF BM
FLSTN BN

DYNA MODELS

FXDL GD
FXDWG GE
FXDS-CON GG

INNER FAIRING, RADIO, CADDY & GAUGES - FLT

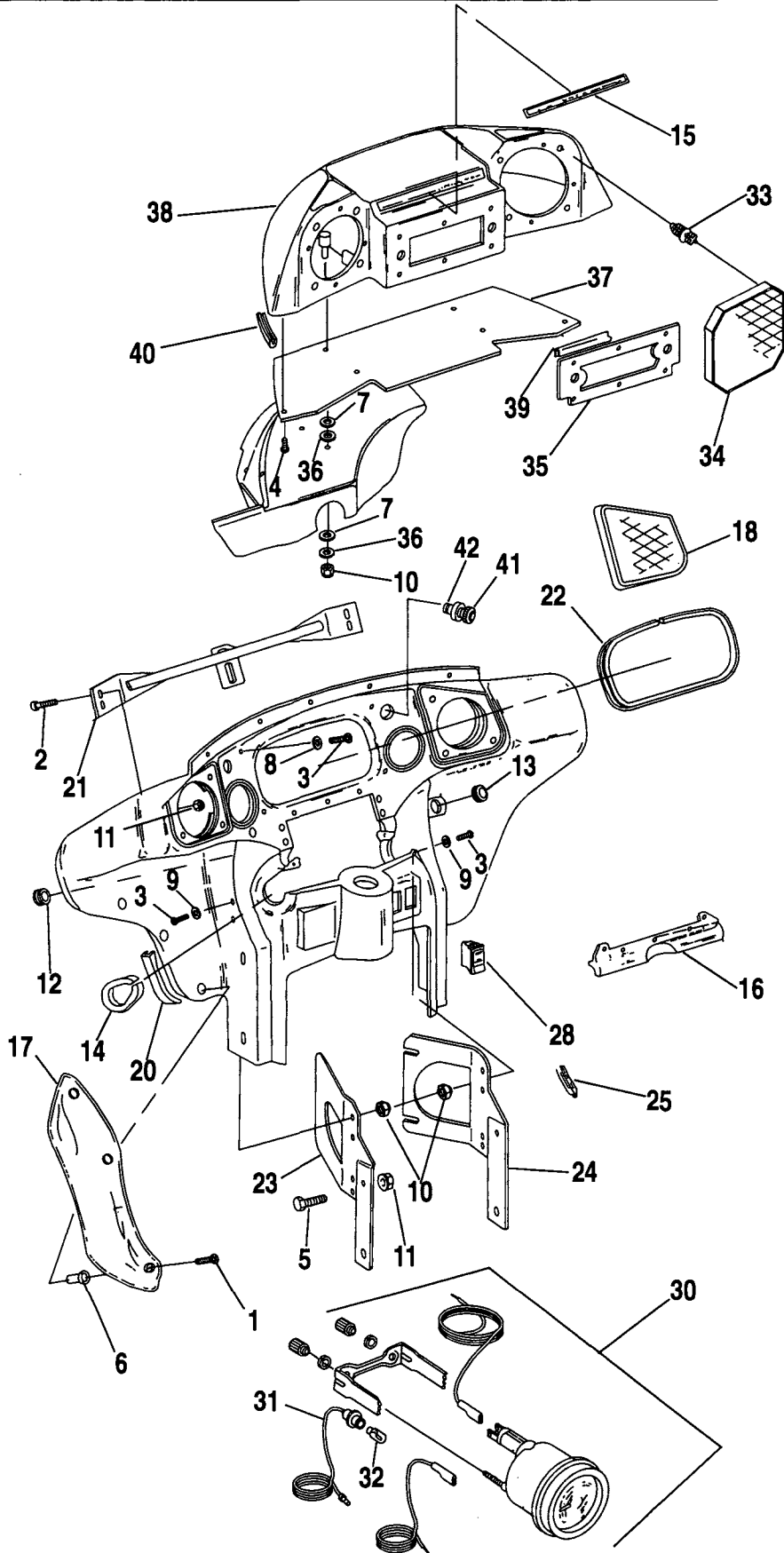

INDEX NO.	PART NO.	DESCRIPTION	FLT MODELS	FXR MODELS	SOFTAIL MODELS	DYNA MODELS
1	922	SCREW (6)	93*-DP	--	--	--
2	924	SCREW (4)	93*-DJ/P	--	--	--
3	2513	SCREW (8)	93*-DJ/P	--	--	--
4	2623W	SCREW (4)	93*-DM	--	--	--
5	3574	BOLT (4)	93*-DJ/P	--	--	--
6	5210	WELL NUT (6)	93*-DP	--	--	--
7	6253W	WASHER (8)	93*-DM	--	--	--
8	6411	WASHER (4)	93*-DJ/P	--	--	--
9	7017	WASHER (4)	93*-DJ/P	--	--	--
10	7686	LOCKNUT (4)	93*-DJ/M/P	--	--	--
11	7716	LOCKNUT (4)	93-DJ/P	--	--	--
	7680	NUT (4)	94*-DJ/P	--	--	--
12	11445	GROMMET, clutch cable	93*-DJ/P	--	--	--
13	11422	GROMMET, throttle cables	93*-DJ/P	--	--	--
14	11453	GROMMET (2)	93*-DJ/M/P	--	--	--
15	14223-89	DECAL, radio caddy	93*-DM	--	--	--
16	56109-88	HANDLEBAR COVER (black)	93*-DJ/P	--	--	--
17	58128-89	AIR DEFLECTOR, right	93*-DP	--	--	--
	58129-89	AIR DEFLECTOR, left	93*-DP	--	--	--
18	58184-86	SPEAKER GRILLE, left	93*-DJ/P	--	--	--
	58186-86	SPEAKER GRILLE, right	93*-DJ/P	--	--	--
20	58311-86	MOLDING, inner fairing	93*-DJ/P	--	--	--
21	58322-88A	CROSS BRACE	93*-DJ/P	--	--	--
22	58415-86A	SEAL, instrument panel	93*-DJ/P	--	--	--
23	58478-86A	BRACKET, left	93*-DJ/P	--	--	--
24	58479-86A	BRACKET, right	93*-DJ/P	--	--	--
	58480-88	WIRING HARNESS, gauges (not illustrated)	93*-DJ/P	--	--	--
25	61648-85	MOLDING	93*-D/J/P	--	--	--
	70158-89	HARNESS, lighter (not illustrated)	93*-DP	--	--	--
	70349-92	HARNESS, speakers (not illustrated)	93-DP	--	--	--
28	71505-89	SWITCH, passing lamps	93*-DJ/P	--	--	--
30	74526-86	VOLTMETER	93*-DJ/P	--	--	--
	74527-86	VOLTMETER	93*-DM	--	--	--
	75032-87	GAUGE, oil pressure	93*-DJ/M/P	--	--	--
31	75044-84	SOCKET, w/ wires (2)	93*-DJ/P	--	--	--
32	75045-84	BULB, 12 V. (2)	93*-DJ/P	--	--	--
33	76175-86	CLIP, double end (8)	93*-DM	--	--	--
34	76176-86	SPEAKER GRILLE	93*-DM	--	--	--
35	76238-86	BRACKET, radio - front	93*-DM	--	--	--
36	77004-80	WASHER (rubber) (8)	93*-DM	--	--	--
37	77036-86	BOTTOM, radio caddy	93*-DM	--	--	--
38	77070-88A	RADIO CADDY (black)	93*-DM	--	--	--
39	77060-86	MOLDING, radio caddy	93*-DM	--	--	--
40	91721-82	MOLDING, radio caddy	93*-DM	--	--	--
41	91808-89	ELEMENT, cigarette lighter	93*-DM/P	--	--	--
42	91812-89	SOCKET, cigarette lighter	93*-DM/P	--	--	--

FLT MODELS
 FLHTC DJ
 FLTC-U DM
 FLHTC-U DP
 FLHS FA
 FLHR FD

FXR MODELS
 FXR EA
 FXRS-SP EG
 FXLR EL
 FXRS-CON EM

SOFTAIL MODELS
 FLSTC BJ
 FXSTC BK
 FXSTS BL
 FLSTF BM
 FLSTN BN

DYNA MODELS
 FXDL GD
 FXDWG GE
 FXDS-CON GG

WINDSHIELD - FLHS, FLHR & FLSTC

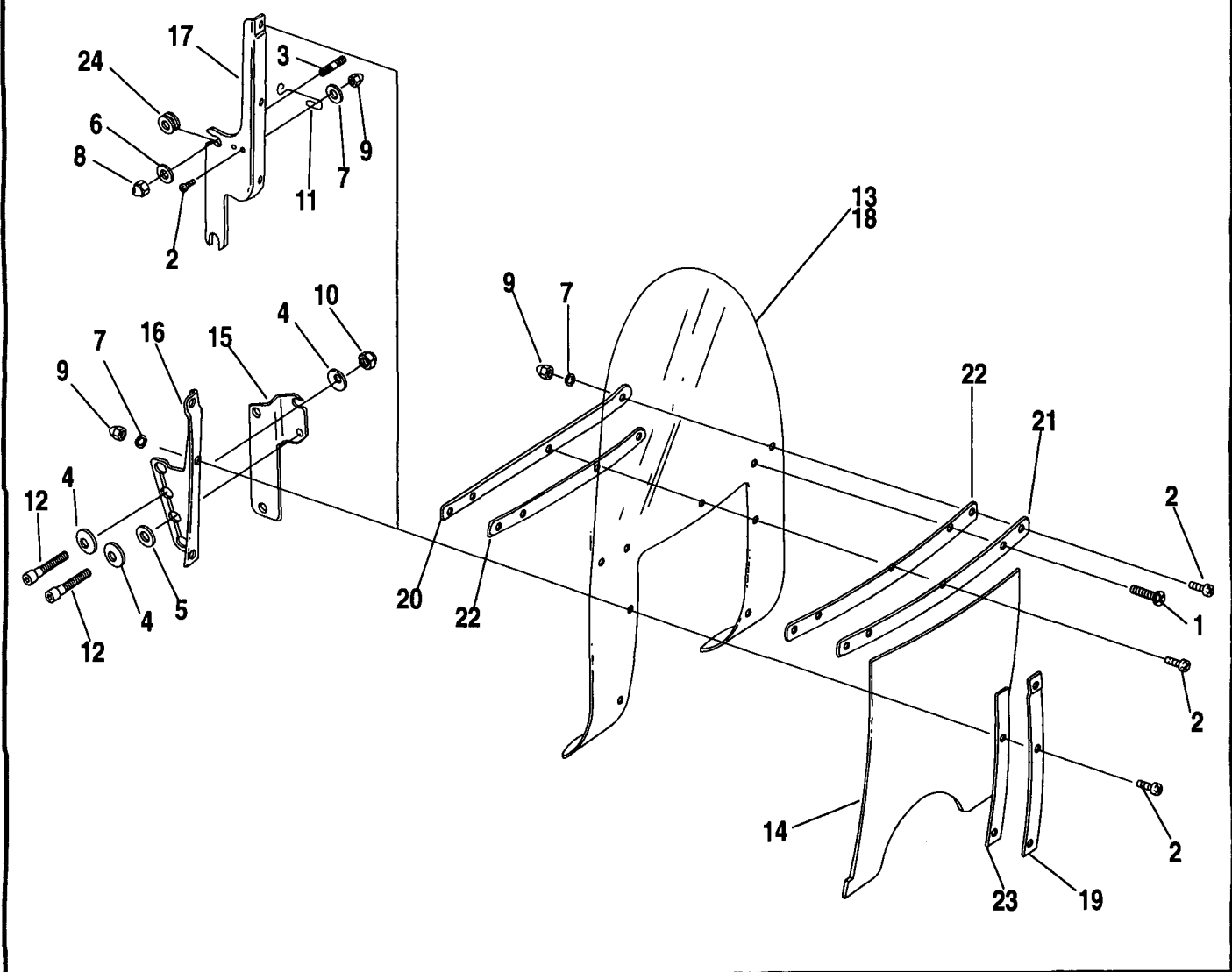

INDEX NO.	PART NO.	DESCRIPTION	FLT MODELS	FXR MODELS	SOFTAIL MODELS	DYNA MODELS
1	2444	SCREW (2)	93-FA;94*-FD--		93*-BJ	--
2	2921	SCREW (7;11-FD)	93-FA;94*-FD--		93*-BJ	--
3	3263	STUD (4)	94*-FD	--	--	--
4	6068	WASHER, Belleville (6)	93-FA	--	--	--
5	6127	WASHER (2)	93-FA	--	--	--
	6645	WASHER(4)	--	--	93*-BJ	--
6	6352	WASHER (chrome)(4)	94*-FD	--	--	--
7	7073	LOCKWASHER (9;13-FD)	93-FA;94*-FD--		93*-BJ	--
8	7507	ACORN NUT (4)	94*-FD	--	--	--
9	7651	ACORN NUT (9;13-FD)	93-FA;94*-FD--		93*-BJ	--
10	7686	LOCKNUT (2)	93-FA	--	--	--
11	38722-94	SPRING LATCH (2)	94*-FD	--	--	--
12	52255-93	BOLT, shoulder (4)	93-FA	--	--	--
13	57994-94	WINDSHIELD ASSEMBLY, complete	94*-FD	--	--	--
	57999-93	WINDSHIELD ASSEMBLY, complete	93-FA	--	--	--
	58018-86	WINDSHIELD ASSEMBLY, complete	--	--	93*-BJ	--
14	58036-83	WINDOW, adjustable	93-FA	--	--	--
	58075-86	WINDOW, adjustable	--	--	93*-BJ	--
15	58067-93	WINDSHIELD BRACKET, left	93-FA	--	--	--
	58068-93	WINDSHIELD BRACKET, right	93-FA	--	--	--
16	58078-49	ADJUSTING BRACKET, right	--	--	93*-BJ	--
	58079-49	ADJUSTING BRACKET, left	--	--	93*-BJ	--
	58080-93	ADJUSTING BRACKET, right	93-FA	--	--	--
	58081-93	ADJUSTING BRACKET, left	93-FA	--	--	--
17	58084-94	ADJUSTING BRACKET, right	94*-FD	--	--	--
	58088-94	ADJUSTING BRACKET, left	94*-FD	--	--	--
18	58183-78	WINDOW REPLACEMENT KIT	93-FA	--	93*-BJ	--
	58193-94	WINDOW REPLACEMENT KIT	94*-FD	--	--	--
19	58406-75A	BRACE, right	93-FA;94*-FD--		93*-BJ	--
	58408-75A	BRACE, left	93-FA;94*-FD--		93*-BJ	--
20	58411-76A	BRACE, inner	93-FA	--	93*-BJ	--
	58431-94	BRACE, inner	94*-FD	--	--	--
21	58412-76A	BRACE, outer	93-FA	--	93*-BJ	--
	58428-94	BRACE, outer	94*-FD	--	--	--
22	58416-77A	TAPE (2)	94-FA;94*-FD--		93*-BJ	--
23	58417-77	TAPE (2)	93-FA;94*-FD--		93*-BJ	--
24	67621-94	BUSHING (4)	94*-FD	--	--	--

FLT MODELS

FLHTC DJ
 FLTC-U DM
 FLHTC-U DP
 FLHS FA
 FLHR FD

FXR MODELS

FXR EA
 FXRS-SP EG
 FXLR EL
 FXRS-CON EM

SOFTAIL MODELS

FLSTC BK
 FXSTC BL
 FLSTF BM
 FLSTN BN

DYNA MODELS

FXDL GD
 FXDWG GE
 FXDS-CON GG

WINDSHIELD - FXRS-CON & FXDS-CON

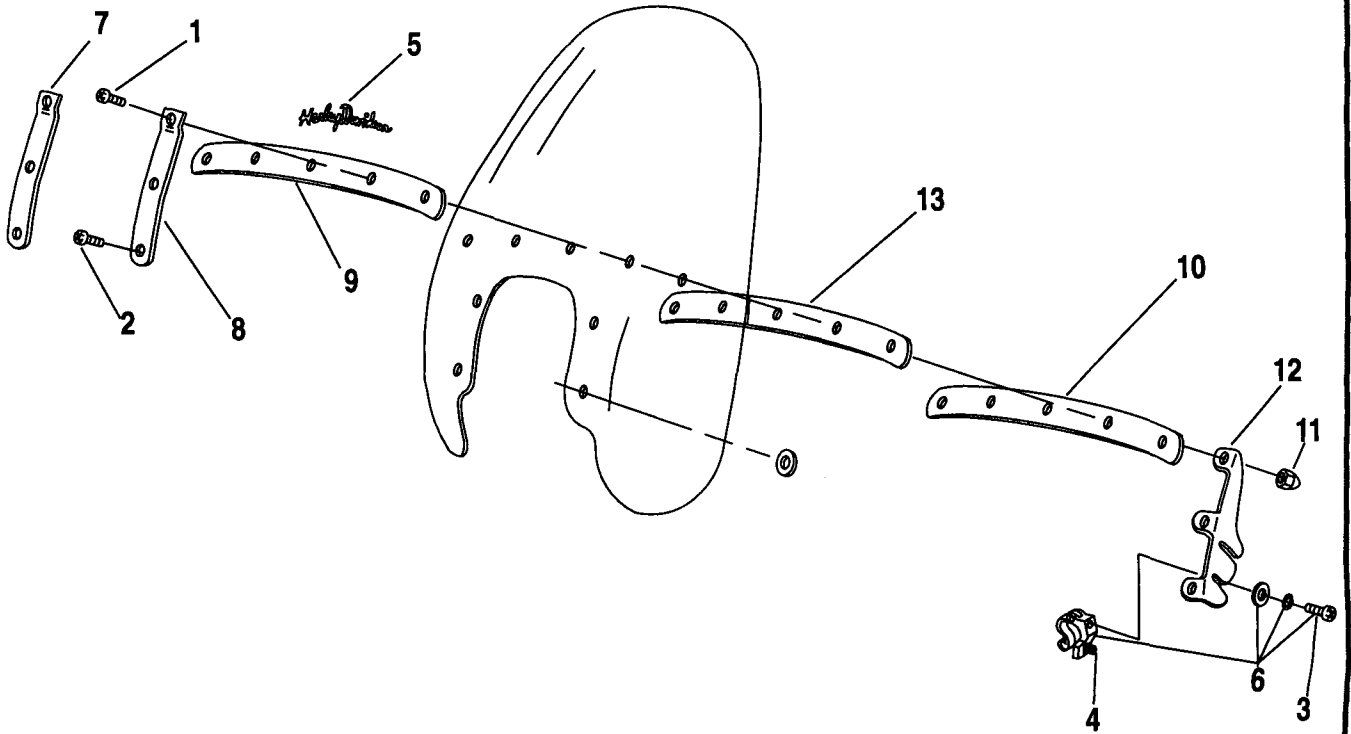

INDEX NO.	PART NO.	DESCRIPTION	FLT MODELS	FXR MODELS	SOFTAIL MODELS	DYNA MODELS
1	1000	SCREW (7)	--	93*-EM	--	94*-GG
2	2151	SCREW (2)	--	93*-EM	--	94*-GG
3	4363	SCREW (4)	--	93*-EM	--	94*-GG
4	4364	SCREW (4)	--	93*-EM	--	94*-GG
5	14227-88	DECAL "Harley-Davidson"	--	93*-EM	--	94*-GG
6	58109-88B	WINDSHIELD CLAMP (4)	--	93*-EM	--	94*-GG
7	58419-88	BRACE, right (chrome)	--	93*-EM	--	94*-GG
8	58420-88	BRACE, left (chrome)	--	93*-EM	--	94*-GG
9	58421-88	BRACE, outer (chrome)	--	93*-EM	--	94*-GG
10	58422-88	BRACE, inner	--	93*-EM	--	94*-GG
11	58423-88	ACORN NUT (9)	--	93*-EM	--	94*-GG
12	58424-88	MOUNTING BRACKET, right	--	93*-EM	--	94*-GG
	58425-88	MOUNTING BRACKET, left	--	93*-EM	--	94*-GG
13	58426-88	CUSHION TAPE, (2 - Cut to suit.)	--	93*-EM	--	94*-GG
	91849-85B	WINDSHIELD, complete	--	93*-EM	--	94*-GG

FLT MODELS

FLHTC DJ
 FLTC-U DM
 FLHTC-U DP
 FLHS FA
 FLHR FD

FXR MODELS

FXR EA
 FXRS-SP EG
 FXLR EL
 FXRS-CON EM

SOFTAIL MODELS

FLSTC BJ
 FXSTC BK
 FXSTS BL
 FLSTF BM
 FLSTN BN

DYNA MODELS

FXDL GD
 FXDWG GE
 FXDS-CON GG

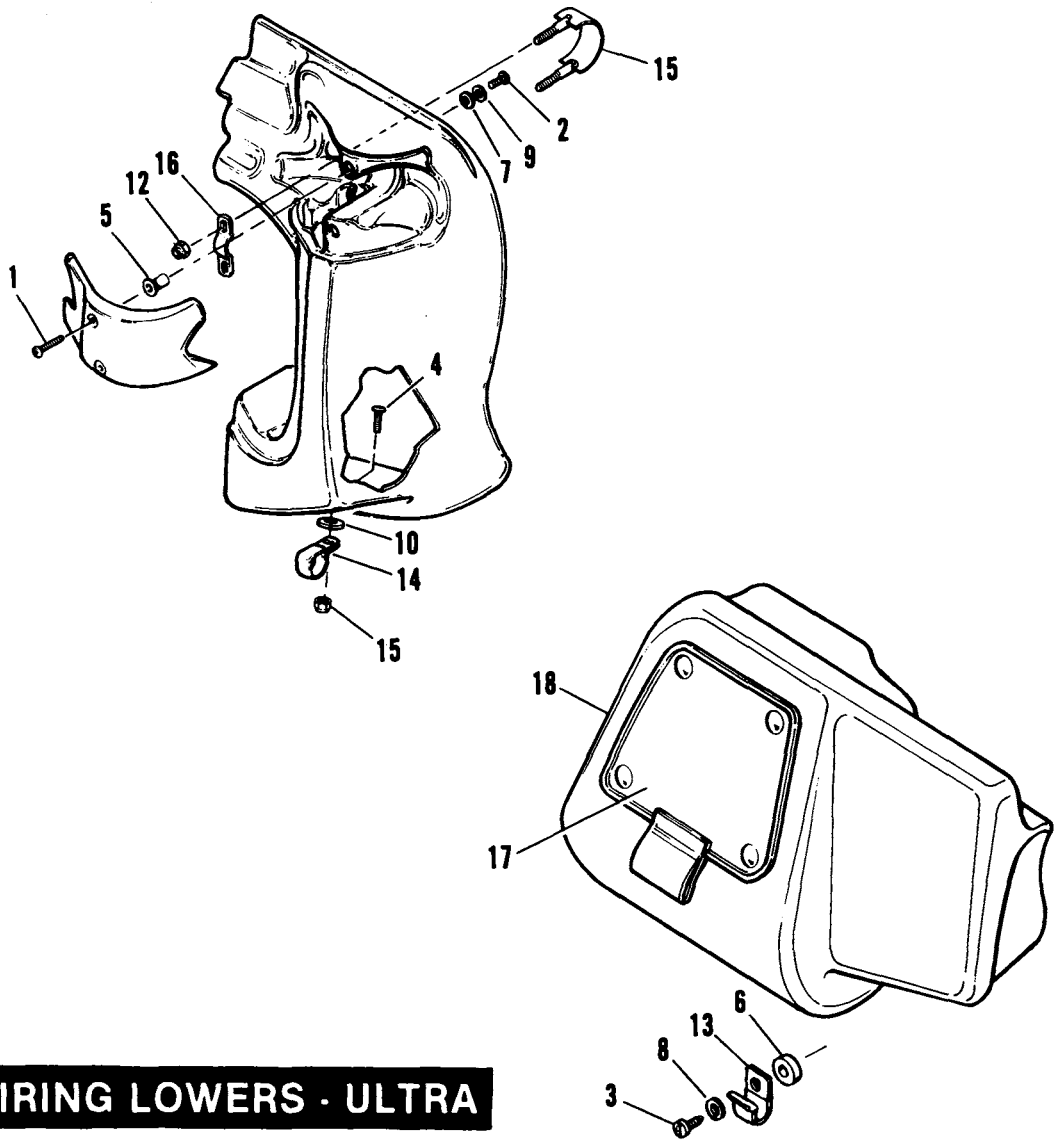

FAIRING LOWERS · ULTRA

INDEX NO.	PART NO.	DESCRIPTION	FLT MODELS	FXR MODELS	SOFTAIL MODELS	DYNA MODELS
NOTE: REFER TO DEALER ACCESSORY GUIDE FOR PAINTED PART NUMBERS.						
1	922	SCREW (4)	93*-DM/P	--	--	--
2	2420	SCREW (2)	93*-DM	--	--	--
3	2592	SCREW	93*-DM	--	--	--
4	2784	SCREW (2)	93*-DM/P	--	--	--
5	5212	NUT, crimp (4)	93*-DM/P	--	--	--
6	5989	SPACER	93*-DM	--	--	--
7	6235	WASHER (2)	93*-DM	--	--	--
8	7220	LOCKWASHER	93*-DM	--	--	--
9	7230	LOCKWASHER (2)	93*-DM	--	--	--
10	7415A	WASHER (rubber) (2)	93*-DM/P	--	--	--
11	7531	NUT, flange (4)	93*-DM/P	--	--	--
12	7716	NUT, flange (4)	93*-DP	--	--	--
13	10092	CLAMP	93*-DM	--	--	--
14	27048-84	CLAMP (2)	93*-DM/P	--	--	--
15	58493-89	U-BOLT (2)	93*-DP	--	--	--
16	58494-89	RETAINER, U-bolt (2)	93*-DP	--	--	--
17	58679-90	DOOR, right	93*-DP	--	--	--
	58681-90	DOOR, left	93*-DP	--	--	--
18	58683-89A	STORAGE BOX - left	93*-DP	--	--	--
	58687-89	STORAGE BOX - left	93*-DM	--	--	--
	58684-89A	STORAGE BOX - right	93*-DP	--	--	--
	58688-89	STORAGE BOX - right	93*-DM	--	--	--
FAIRING LOWER FOR SIDECAR UNIT						
	922	SCREW (4)	93*-DM/P	--	--	--
	2784	SCREW (2)	93*-DM/P	--	--	--
	5212	NUT, crimp (4)	93*-DM/P	--	--	--
	7415A	WASHER (rubber)(2-DM)	93*-DM/P	--	--	--
	7716	NUT, flange (2)	93*-DP	--	--	--
	58493-89	U-BOLT	93*-DM/P	--	--	--
	58494-89	RETAINER, U-bolt	93*-DM/P	--	--	--

FLT MODELS

FLHTC
FLTC-U
FLHTC-U
FLHS
FLHR

DJ
DM
DP
FA
FD

FXR MODELS

FXR
FXRS-SP
FXLR
FXRS-CON
EA
EG
EL
EM

SOFTAIL MODELS

FLSTC
FXSTC
FXSTS
FLSTF
FLSTN
BJ
BK
BL
BM
BN

DYNA MODELS

FXDL
FXDWG
FXDS-CON
GD
GE
GG

NACELLE & HEADLAMP - FLHR

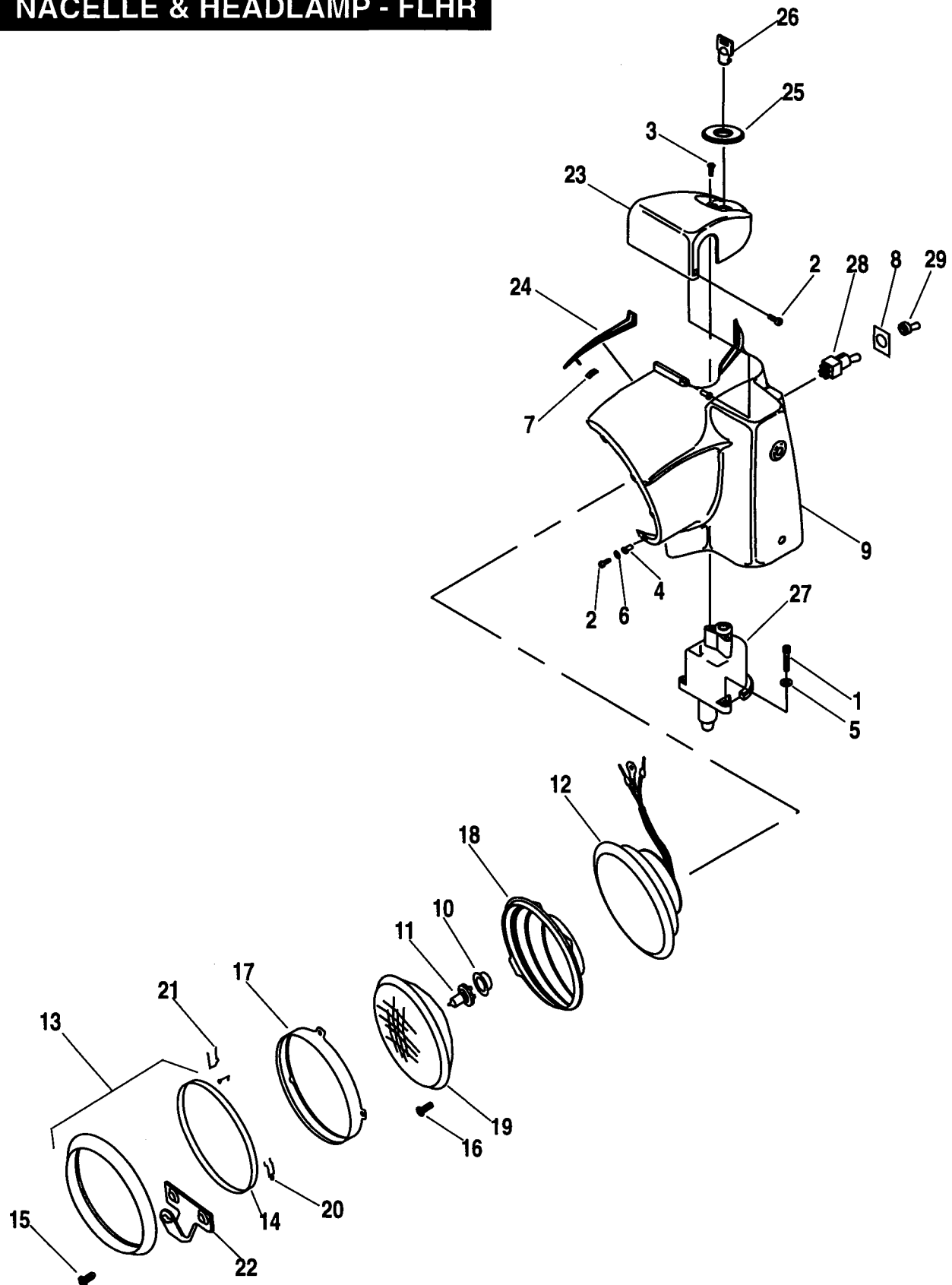

INDEX NO.	PART NO.	DESCRIPTION	FLT MODELS	FXR MODELS	SOFTAIL MODELS	DYNA MODELS
1	2647B	SCREW (2)	94*-FD	--	--	--
2	2806	SCREW (10)	94*-FD	--	--	--
3	2933	SCREW (2)	94*-FD	--	--	--
4	5210	WELLNUT (10)	94*-FD	--	--	--
5	6150W	WASHER (2)	94*-FD	--	--	--
6	6717	WASHER (8)	94*-FD	--	--	--
7	7613A	PUSH NUT	94*-FD	--	--	--
8	14019-83	LABEL, spotlight	94*-FD	--	--	--
	68601-94	LABEL, accy.	94*-FD	--	--	--
	53571-94	LOCK SET, complete vehical	94*-FD	--	--	--
9	67674-94	NACELLE, right	94*-FD	--	--	--
	67862-94	NACELLE, left	94*-FD	--	--	--
10	67696-81	BOOT, bulb	94*-FD	--	--	--
11	67697-81	BULB (Halogen H-4)	94*-FD	--	--	--
12	67702-81A	HEADLAMP ASM. w/ housing - 7"	94*-FD	--	--	--
13	67712-83	DOOR ASM, w/ spring (chrome)	94*-FD	--	--	--
14	67716-60A	GASKET, headlamp door	94*-FD	--	--	--
15	67718-60A	SCREW, headlamp door	94*-FD	--	--	--
16	67724-71	ADJUSTING SCREW (3)	94*-FD	--	--	--
17	67726-71	RETAINING RING	94*-FD	--	--	--
18	67732-71	MOUNTING RING	94*-FD	--	--	--
19	67755-81A	LENS, less bulb w/ boot	94*-FD	--	--	--
20	67778-60	TOP SPRING	94*-FD	--	--	--
21	67780-60	BOTTOM SPRING (2)	94*-FD	--	--	--
22	67782-60A	BRACKET	94*-FD	--	--	--
23	67866-94	COVER, handlebar	94*-FD	--	--	--
24	67868-94	TRIM, nacelle	94*-FD	--	--	--
25	71310-94	TRIM ASM., fork lock	94*-FD	--	--	--
26	71452-91A	KEYSET (specify 4-digit key code)	94*-FD	--	--	--
27	71540-94	FORK LOCK	94*-FD	--	--	--
28	71522-94	SWITCH, spotlight & accy. (2)	94*-FD	--	--	--
29	74408-89	BOOT (2)	94*-FD	--	--	--
H-D INTERNATIONAL ONLY						
	53438-92	BULB, position lamp (HDI only)	94*-FD	--	--	--
	67793-92	LENS ASM. w/ bulb & boot, R.H. dip (HDI only)	94*-FD	--	--	--
	67801-92	LENS ASM. w/ bulb & boot, L.H. dip (HDI only)	94*-FD	--	--	--
	67798-92	BOOT, bulb	94*-FD	--	--	--
	68654-92	SOCKET, position lamp	94*-FD	--	--	--

FLT MODELS

FLHTC DJ
 FLTC-U DM
 FLHTC-U DP
 FLHS FA
 FLHR FD

FXR MODELS

FXR EA
 FXRS-SP EG
 FXLR EL
 FXRS-CON EM

SOFTAIL MODELS

FLSTC BJ
 FXSTC BK
 FXSTS BL
 FLSTF BM
 FLSTN BN

DYNA MODELS

FXDL GD
 FXDWG GE
 FXDS-CON GG

HEADLAMP

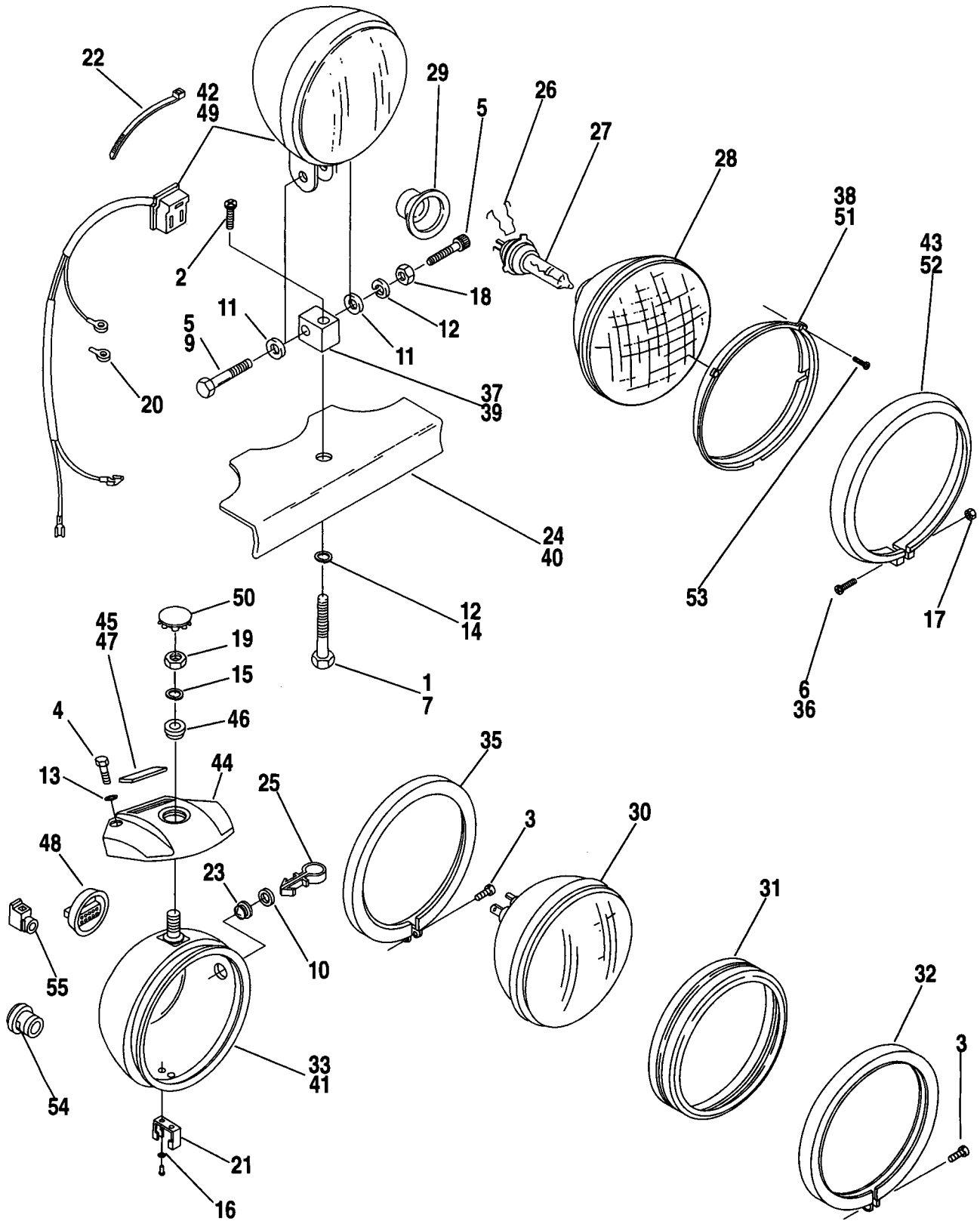

INDEX NO.	PART NO.	DESCRIPTION	FLT MODELS	FXR MODELS	SOFTAIL MODELS	DYNA MODELS
1	854A	SCREW	--	93*-EL	--	--
2	861A	BOLT	--	--	93*-BL	--
3	1203	SCREW (2)	--	93*-EA/G/M	--	--
4	4017	SCREW (2)	--	93*-EA/G/M	--	93*-GD/G
5	2917	SCREW (2)	--	--	93*-BL	--
6	3514	SCREW	--	93*-EL	93*-ALL	93*-ALL
7	3945	BOLT	--	--	93*-BK/M	93*-GE
9	4411	BOLT	--	--	93*-BM	--
	4724	BOLT	--	--	93*-BK	93*-GE
10	6265	WASHER	--	93*-EG/M	--	--
11	6701	WASHER (2)	--	--	93*-BK/M	93*-GE
	6379W	WASHER (2)	--	--	93*-BL	--
12	7038	LOCKWASHER (2 - BK)	--	--	93*-BJ/K/ M/N	--
13	7041	LOCKWASHER (2)	--	93*-EA/G/M	--	93*-GD/G
14	7045	LOCKWASHER	--	93*-EL	--	--
15	7068	LOCKWASHER	--	93*-EA/G/M	--	93*-GD/G
16	7220	LOCKWASHER	--	93*-EA/G/M	--	--
17	7606	NUT	--	93*-EL	93*-BK	93*-ALL
18	7800W	NUT	--	--	93*-BK/M	93*-GE
19	7880	NUT	--	93*-EA/G/M	--	93*-GD/G
20	9857	TERMINAL, headlamp harness - ring type	--	--	93*-ALL	--
21	9952	CLIP	--	93*-EA/G/M	--	--
22	10065	CABLE STRAP	--	--	93*-ALL	--
23	11448	PLUG	--	93*-EA/G/M	--	--
24	45685-93	MOUNTING PLATE	--	--	--	93*-GE
25	56073-83	RETAINER, cable	--	93*-EG/M	--	--
26	67685-92	CLIP, bulb	--	93*-ALL	93*-BK/L	93*-ALL
27	67697-81	BULB, halogen-H-4	--	93*-ALL	93*-BK/L	93*-ALL
28	67698-81C	HEADLAMP ASM. w/ bulb, boot & clip - 5-3/4"	--	93*-ALL	93*-BL	93*-ALL
	67757-92	LENS w/ clip	--	93*-ALL	93*-BL	93*-ALL
29	67705-92	BOOT, connector	--	93*-ALL	93*-BK/L	93*-ALL
30	67713-86	SEALED BEAM UNIT - 7"	--	--	93*-BJ/M/N	--
31	67719-63	MOUNTING RING	--	93*-EA/G/M	--	--
32	67725-63	MOLDING, outer	--	93*-EA/G/M	--	--
33	67730-91	HOUSING, headlamp (black)	--	--	--	93*-GD/G
	67743-84	HOUSING, headlamp (black)	--	--	93*-EA/G/M	--
35	67744-75	MOLDING, inner	--	93*-EA/G/M	--	--
36	67748-87	SCREW, door (chrome)	--	--	93*-BJ/M/N	--
37	67762-87	MOUNTING BLOCK	--	93*-EL	--	--
	67768-86	MOUNTING BLOCK	--	--	93*-BJ/M/N	--
	67892-93	MOUNTING BLOCK	--	--	93*-BL	--
38	67769-82	MOUNTING RING	--	93-EL	93-BK	93-ALL
	67769-93	MOUNTING RING	--	94*-EL	94*-BK	94*-ALL
39	67772-80	MOUNTING BLOCK	--	--	93*-BK	93*-GE
40	67773-80A	MOUNTING PLATE	--	--	93*-BK	--

FLT MODELS

FLHTC
FLTC-U
FLHTC-U
FLHS
FLHR

DJ
DM
DP
FA
FD

FXR MODELS

FXR
FXRS-SP
FXLR
FXRS-CON

EA
EG
EL
EM

SOFTAIL MODELS

FLSTC
FXSTC
FXSTS
FLSTF
FLSTN

BJ
BK
BL
BM
BN

DYNA MODELS

FXDL
FXDWG
FXDS-CON

GD
GE
GG

HEADLAMP

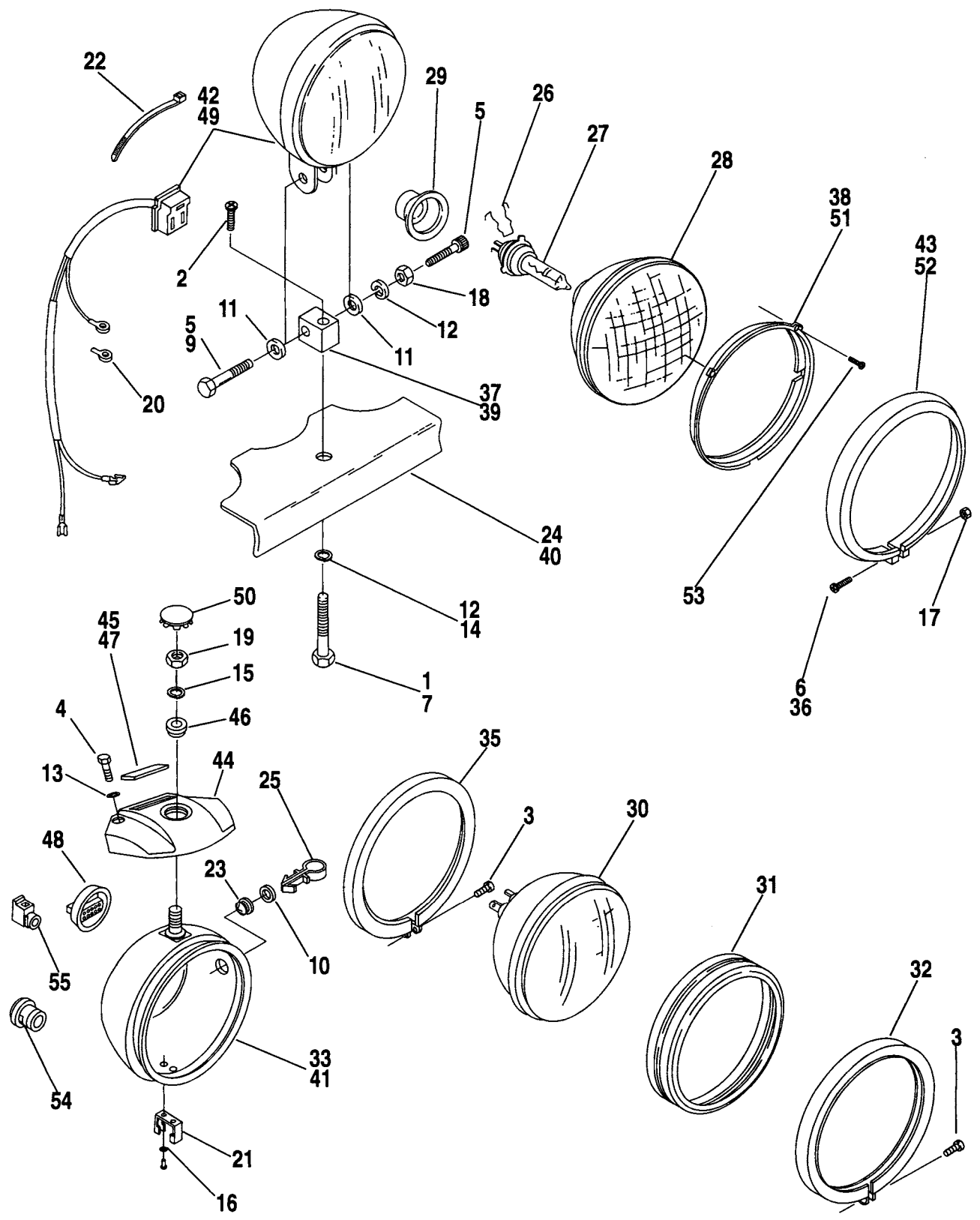

INDEX NO.	PART NO.	DESCRIPTION	FLT MODELS	FXR MODELS	SOFTAIL MODELS	DYNA MODELS
41	67777-80A	HEADLAMP ASM. w/ housing & wiring - 5-3/4"	--	93*-EL	93*-BK	93*-GE
42	67789-91	HEADLAMP ASM. w/ housing & wiring - 7"	--	--	93*-BJ/M/N	--
43	67790-82	TRIM RING (chrome)	--	93-EL	93-BK	93-ALL;
	67790-93	TRIM RING (chrome)	--	94*-EL	94*-BK	94*-ALL
	67894-93	TRIM RING (chrome)	--	--	93*-BL	--
44	67805-92	BRACKET (chrome)	--	93*-EA/G/M	--	93*-GD/G
45	67807-92	TRIM, warning lights	--	93*-EA/B	--	93*-GD
46	67815-59A	WASHER	--	93*-EA/G/M	--	93*-GD/G
47	67834-83	TRIM, headlamp bracket	--	93*-EB/G/M	--	94*-GG
	68516-92	TRIM, warning lights	--	--	--	93*-GD/G
48	67839-74	BOOT, headlamp connector	--	93*-EA/G/M	--	--
49	67841-93	HEADLAMP ASM. w/ housing & wiring - 5-3/4"	--	--	93*-BL	--
50	67865-89	PLUG, headlamp bracket	--	93*-EA/G/M	--	93*-GD/G
51	68050-93	RETAINING RING	--	--	93*-BJ/M/N	--
52	68051-93	TRIM RING (chrome)	--	--	93*-BJ/M/N	--
53	68052-93	SCREW (3)	--	--	93*-BJ/M/N	--
	68705-93	HEADLAMP CONNECTOR KIT w/ wires	--	93*-ALL	--	--
54	72501-74	BUSHING, straight	--	93*-EA/G/M	--	--
55	72502-74	BUSHING, angle (2)	--	93*-EA/G/M	--	--
H-D INTERNATIONAL ONLY						
	53438-92	BULB, position lamp (HDI only)	--	94*-ALL	94*-ALL	94*-ALL
28	67763-93	LENS ASM., w/ bulb & boot - R.H. Dip (HDI only)	--	94*-ALL	94*-BK/L	94*-ALL
	67781-92	LENS ASM., w/ bulb & boot - L.H. Dip (HDI only)	--	94*-ALL	94*-BK/L	94*-ALL
30	67793-92	LENS ASM., w/ bulb & boot - R.H. Dip (HDI only)	--	--	94*-BJ/M/N	--
	67801-92	LENS ASM., w/ bulb & boot - L.H. Dip (HDI only)	--	--	94*-BJ/M/N	--
29	67798-92	BOOT, (HDI only)	--	--	93*-BJ/M/N	--
42	67823-92	HEADLAMP, complete with wiring - 7" (Less bulb) (HDI only)	--	--	93*-BJ/M/N	--
41	67849-93	HEADLAMP, complete with wiring - 5-3/4" (Less bulb) (HDI only)	--	--	93*-BL	--
	67872-89A	HEADLAMP, complete with wiring - 5-3/4" (Less bulb) (HDI only)	--	93*-EL	93*-BK	--
	68654-92	SOCKET, position lamp (HDI only)	--	94*-ALL	94*-ALL	94*-ALL
	70048-92	WIRE, headlamp (HDI only)	--	93*-EA/G/M	--	--

FLT MODELS

FLHTC DJ
 FLTC-U DM
 FLHTC-U DP
 FLHS FA
 FLHR FD

FXR MODELS

FXR EA
 FXRS-SP EG
 FXLR EL
 FXRS-CON EM

SOFTAIL MODELS

FLSTC BJ
 FXSTC BK
 FXSTS BL
 FLSTF BM
 FLSTN BN

DYNA MODELS

FXDL GD
 FXDWG GE
 FXDS-CON GG

PASSING LAMPS & FRONT TURN SIGNALS - FLHTC, FLHS & FLSTC

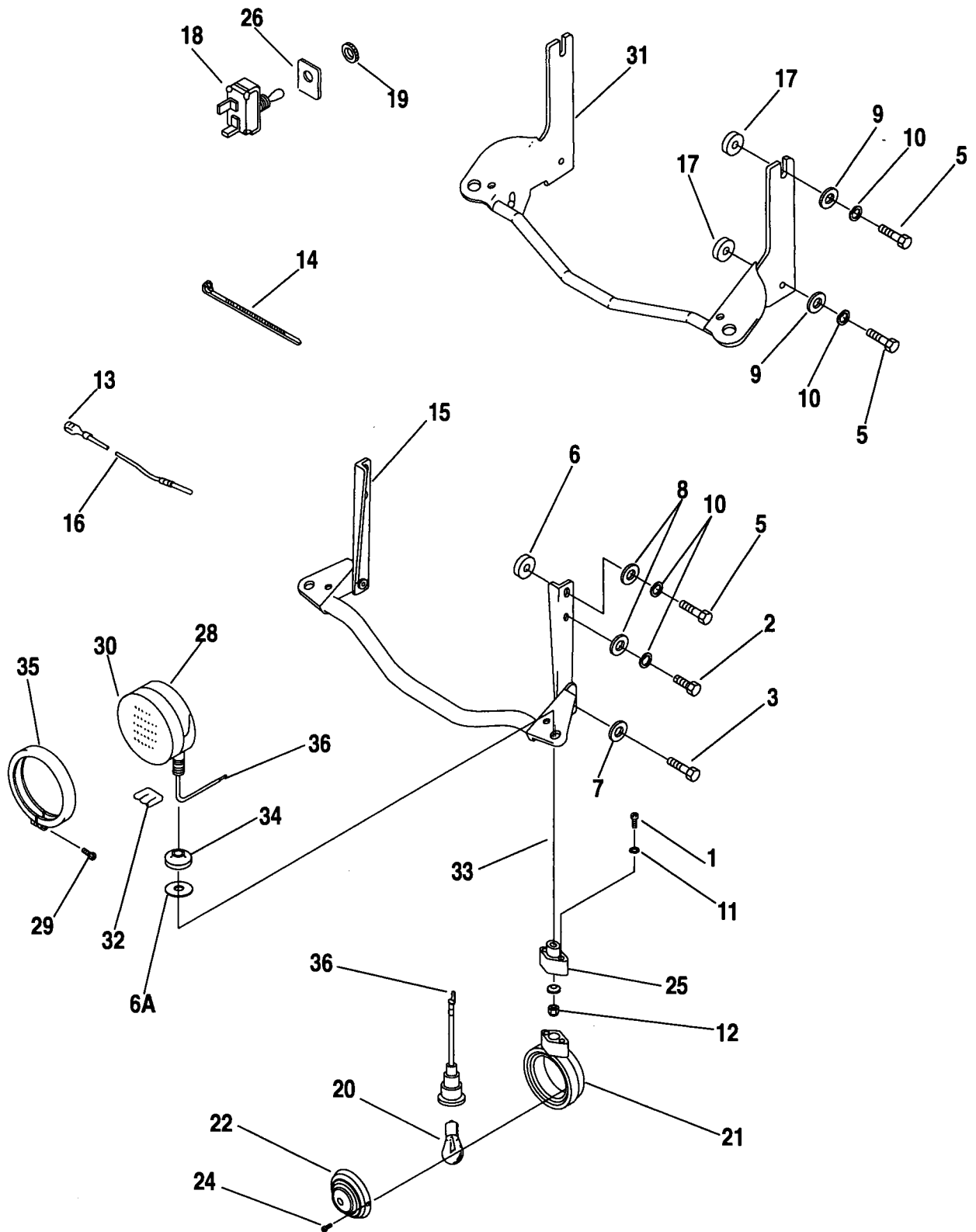

PASSING LAMPS & FRONT TURN SIGNALS - FLHTC, FLHS/R, FLSTC

FB35A-1

INDEX NO.	PART NO.	DESCRIPTION	FLT MODELS	FXR MODELS	SOFTAIL MODELS	DYNA MODELS
1	2647B	SCREW (4)	93-DJ/P,FA; 94*-DJ/P,FD	--	93*-BJ	--
2	3960W	BOLT (2)	--	--	93*-BJ	--
3	4014W	SCREW (2)	--	--	93*-BJ	--
5	4036	BOLT (4 - DJ, FA; 2 - BJ)	93-DJ/P,FA; 94*-DJ/P	--	93*-BJ	--
6	5885	SPACER (2)	--	--	93*-BJ	--
6A	6072	WASHER, belleville (2)	94*-DJ/P,FD	--	94*-BJ	--
7	6109	WASHER (2)	--	--	93*-BJ	--
8	6645	WASHER (4)	--	--	93*-BJ	--
9	6702	WASHER (4 - DJ, FA)	93-DJ/P,FA; 94*-DJ/P	--	--	--
10	7041	LOCKWASHER (4 - DJ, FA; 6 - BJ)	93-DJ/P,FA 94*-DJ/P	--	93*-BJ	--
11	7069	LOCKWASHER (4)	--	--	93*-BJ	--
12	7778	LOCKNUT (2)	93-DJ/P,FA; 94*-DJ/P,FD	--	93*-BJ	--
13	9900 9907	CONNECTOR, passing lamp wire (2) CONNECTOR, passing lamp wire (2)	-- 93-FA; 94*-FD	--	93*-BJ --	-- --
14	10006	CABLE STRAP	--	--	93*-BJ	--
15	58082-87 67615-89	BRACKET, passing lamps WIRING HARNESS, passing lamps (not illust.)	--	--	93*-BJ 93*-BJ	-- --
16	67668-89	CABLE ASSEMBLY, passing lamps	93-FA	--	--	--
17	67749-77	SPACER (4)	93-DJ/P,FA; 94*-DJ/P,FD	--	--	--
18	67858-89	TOGGLE SWITCH, passing lamps	93-FA	--	93*-BJ	--
19	67846-70	NUT, toggle switch	93-FA	--	93*-BJ	--
20	68168-89	BULB, turn signal (2)	93-DJ/P,FA; 94*-DJ/P,FD	--	93*-BJ	--
21	68400-86 68766-94 68661-87 68668-87	TURN SIGNAL (2) TURN SIGNAL (2) TURN SIGNAL, left TURN SIGNAL, right	93-DJ/P,FA 94*-DJ/P,FD -- --	-- -- -- --	-- -- 93*-BJ 93*-BJ	-- -- -- --
22	68440-86	LENS, turn signal (amber) (2)	93-DJ/P,FA; 94*-DJ/P,FD	--	93*-BJ	--
24	68452-86	SCREW (4)	93-DJ/P,FA; 94*-DJ/P,FD	--	93*-BJ	--

FLT MODELS

FLHTC
FLTC-U
FLHTC-U
FLHS
FLHR

DJ
DM
DP
FA
FD

FXR MODELS

FXR
FXRS-SP
FXLR
FXRS-CON
EA
EG
EL
EM

SOFTAIL MODELS

FLSTC
FXSTC
FXSTS
FLSTF
FLSTN
BJ
BK
BL
BM
BN

DYNA MODELS

FXDL
FXDWG
FXDS-CON
GD
GE
GG

PASSING LAMPS & FRONT TURN SIGNALS - FLHTC, FLHS & FLSTC

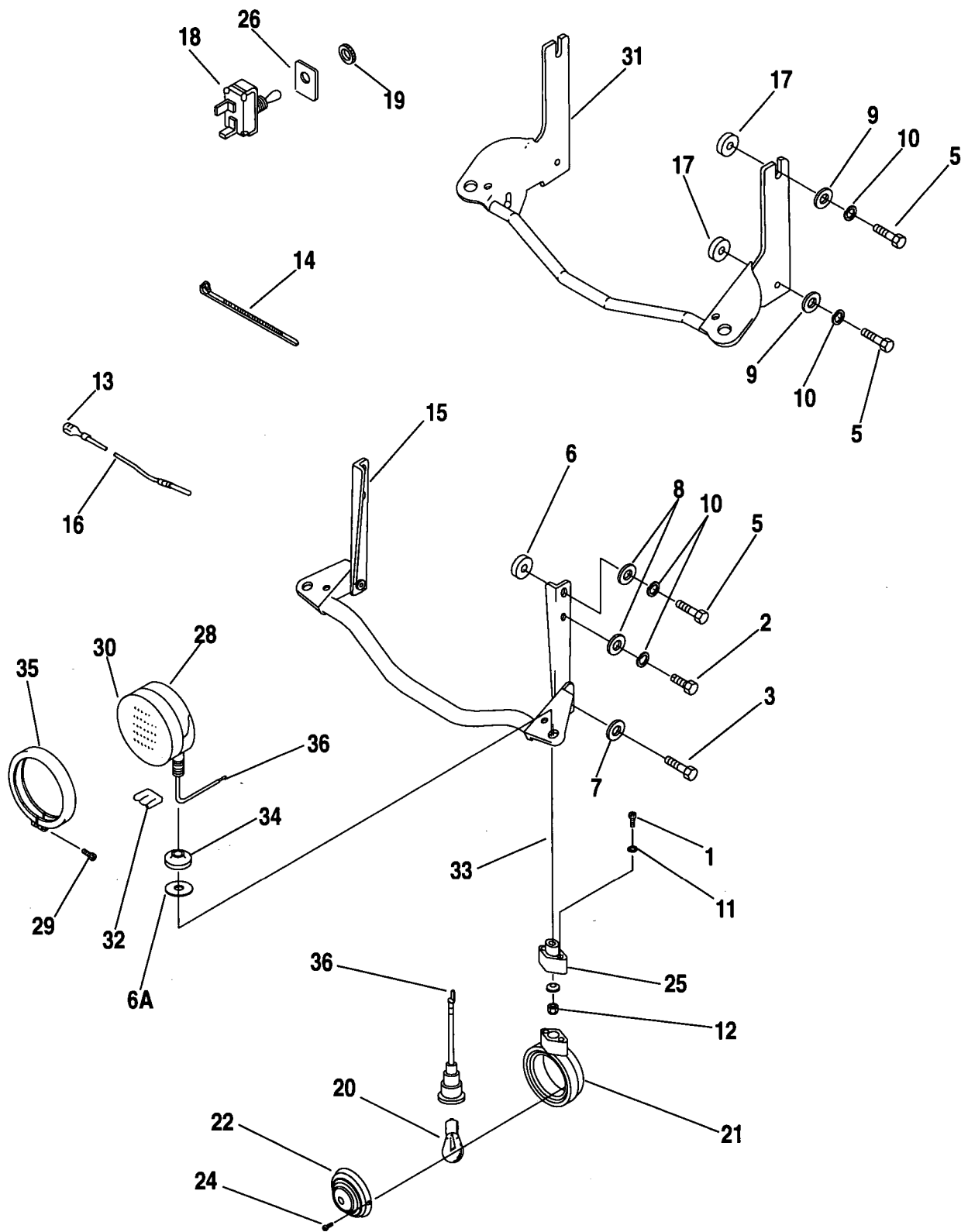

INDEX NO.	PART NO.	DESCRIPTION	FLT MODELS	FXR MODELS	SOFTAIL MODELS	DYNA MODELS
25	68519-68	MOUNTING BRACKET (2)	93-DJ/P,FA 94*-DJ/P,FD	--	93*-BJ	--
26	68619-83	LABEL, passing lamp switch	93-FA	--	93*-BJ	--
27	68633-89	LAMP WIRING, passing lamp	93-FA	--	--	--
28	68671-69A	PASSING LAMP (2)	93-DJ/P,FA; 94*-DJ/P,FD	--	93*-BJ	--
29	68672-38	SCREW, passing lamp molding (2)	93-DJ/P,FA; 94*-DJ/P,FD	--	93*-BJ	--
30	68674-69	SEALED UNIT, passing lamps (2)	93-FA; 94*-FD	--	93*-BJ	--
31	68684-86	BRACKET, passing lamps	93-DJ/P,FA 94*-DJ/P	--	--	--
	68712-94	BRACKET, passing lamps	94*-FD	--	--	--
32	68690-69	CLIP, wire (2)	93-DJ/P,FA	--	93-BJ	--
33	68720-62	CLAMP BLOCK, passing lamps (2)	93-DJ/P,FA; 94*-DJ/P,FD	--	93*-BJ	--
34	68721-62	SWIVEL BLOCK, passing lamps (2)	93-DJ/P,FA; 94*-DJ/P,FD	--	93*-BJ	--
35	68725-62	MOLDING, passing lamps (2)	93-DJ/P,FA; 94*-DJ/P,FD	--	93*-BJ	--
36	72039-71	PIN, single socket (4)	93-DJ/P,FA	--	93*-BJ	--
	72191-94	TERMINAL, socket (8)	94*-DJ/P	--	--	--
H-D INTERNATIONAL ONLY						
26	14019-83	LABEL, park lamp (HDI only)	93-FA	--	--	--
18	67858-39	TOGGLE SWITCH, park lamp (HDI only)	93-FA	--	--	--
21	68401-90	TURN SIGNAL, (2) (HDI only)	93-DJ/P,FA	--	93*-BJ	--
	68767-94	TURN SIGNAL, (2) (HDI only)	94*-DJ/P,FD	--	--	--
22	68505-90	LENS, turn signal (amber) (2) (HDI only)	93-DJ/P,FA 94*-DJ/P,FD	--	93*-BJ	--

FLT MODELS		FXR MODELS		SOFTAIL MODELS		DYNA MODELS	
FLHTC	DJ	FXR	EA	FLSTC	BJ	FXDL	GD
FLTC-U	DM	FXRS-SP	EG	FXSTC	BK	FXDWG	GE
FLHTC-U	DP	FXLR	EL	FXSTS	BL	FXDS-CON	GG
FLHS	FA	FXRS-CON	EM	FLSTF	BM		
FLHR	FD			FLSTN	BN		

FRONT FENDERS

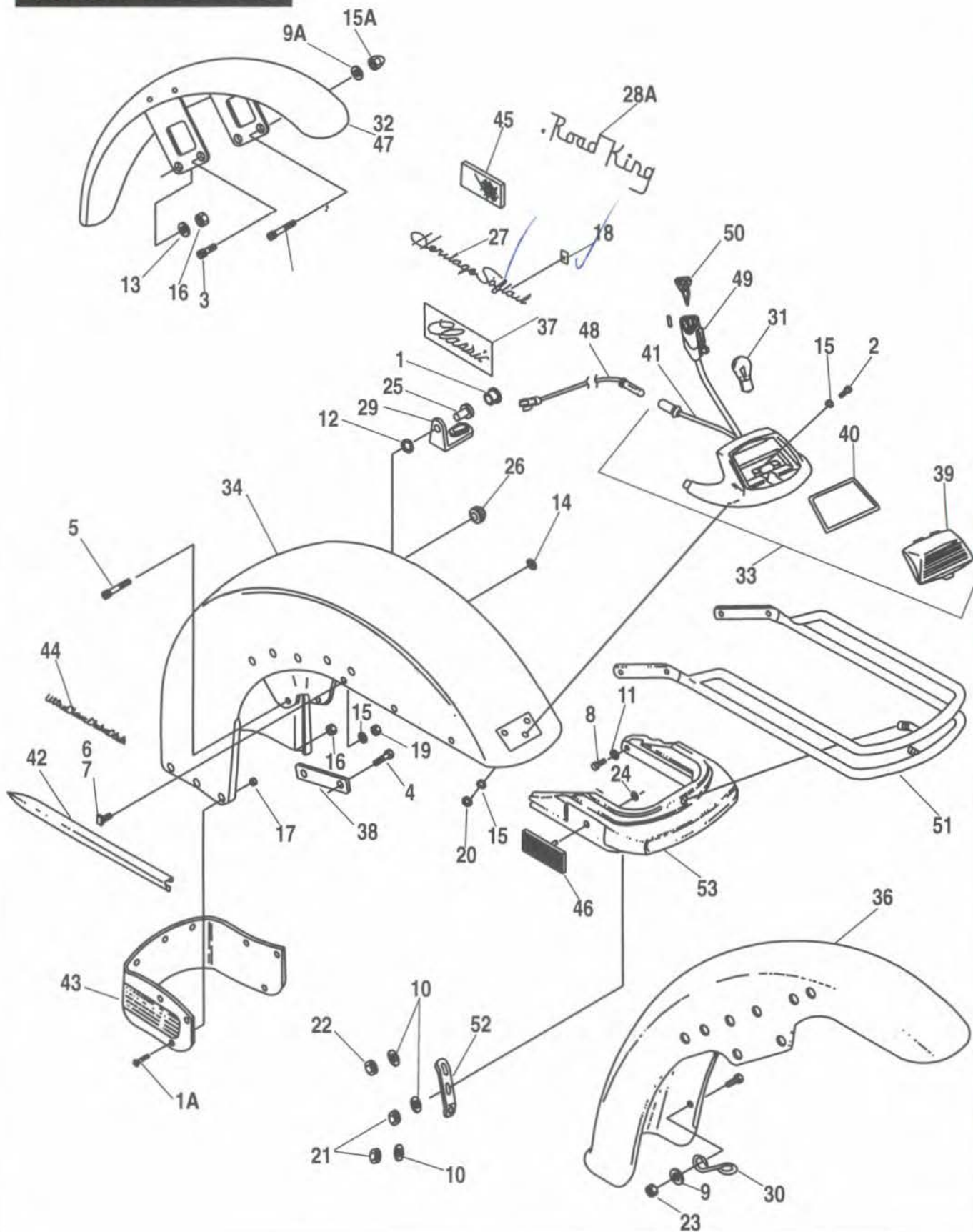

INDEX NO.	PART NO.	DESCRIPTION	FLT MODELS	FXR MODELS	SOFTAIL MODELS	DYNA MODELS
NOTE: REFER TO DEALER ACCESSORY GUIDE FOR PAINTED PART NUMBERS.						
1	755	HOLE PLUG	94*-FD	--	--	--
1A	2531	SCREW (6; 8 - BJ/N)	93*-ALL	--	93*-BJ/N	--
2	2604	SCREW (2)	93*-ALL	--	93*-BJ/N	--
3	3210A	SCREW (4)	--	93*-ALL	--	93*-GD/G
4	3462	BOLT (4)	93*-ALL	--	--	--
5	3485A	SCREW (4)	--	--	93*-BJ/M/K	93*-GE
6	3560W	TEE BOLT (2)	93*-ALL	--	93*-BJ/N	--
7	3561WB	TEE BOLT (2)	93*-ALL	--	93*-BJ/N	--
8	4091	SCREW (2)	93*-DJ/M/P	--	--	--
9	6220W	LOCKWASHER	--	--	93*-BM	--
9A	6702	WASHER (4)	--	--	93*-BK	94*-GE
10	6703	WASHER (3)	93*-DJ/M/P	--	--	--
11	6716	WASHER (2)	93*-DJ/M/P	--	--	--
12	7036	WASHER	93*-ALL 94*-DJ/M/P	--	93*-BJ/N	--
13	7041	LOCKWASHER (4)	--	--	93*-BK	--
14	7127	LOCKWASHER (4)	--	--	93*-BN	--
15	7220	LOCKWASHER (4)	93*-ALL	--	93*-BJ/N	--
15A	7507	ACORN NUT (4)	--	--	93*-BK	94*-GE
16	7531	NUT (4)	--	93*-ALL	93*-BJ	93*-GD/G
17	7600	NUT (6; 8 - BJ/N)	93*-ALL	--	93*-BJ/N	--
18	7613A	PUSH NUT (6)	93*-DM/P 94*-DM/P,FD	--	93*-BJ/N	--
19	7624	NUT (4)	93*-ALL	--	93*-BJ/N	--
20	7629	NUT (2)	93*-ALL	--	93*-BJ/N	--
21	7682	LOCKNUT (2)	93*-DJ/M/P	--	--	--
22	7683	LOCKNUT	93*-DJ/M/P	--	--	--
23	7689W	NUT	--	--	93*-BM	--
24	8126	SPEED NUT, reflector (2)	93*-DJ/M/P	--	--	--
25	8505	RIVET	93*-ALL 94*-DJ/M/P	--	93*-BJ/N	93*-ALL
26	11437	GROMMET, wiring harness	93*-ALL	--	--	--
27	14142-86	TRIM, "Heritage Softail" (2)	--	--	93*-BJ/N	--

FLT MODELS

FLHTC DJ
 FLTC-U DM
 FLHTC-U DP
 FLHS FA
 FLHR FD

FXR MODELS

FXR EA
 FXRS-SP EG
 FXLR EL
 FXRS-CON EM

SOFTAIL MODELS

FLSTC BJ
 FXSTC BK
 FXSTS BL
 FLSTF BM
 FLSTN BN

DYNA MODELS

FXDL GD
 FXDWG GE
 FXDS-CON GG

FRONT FENDERS

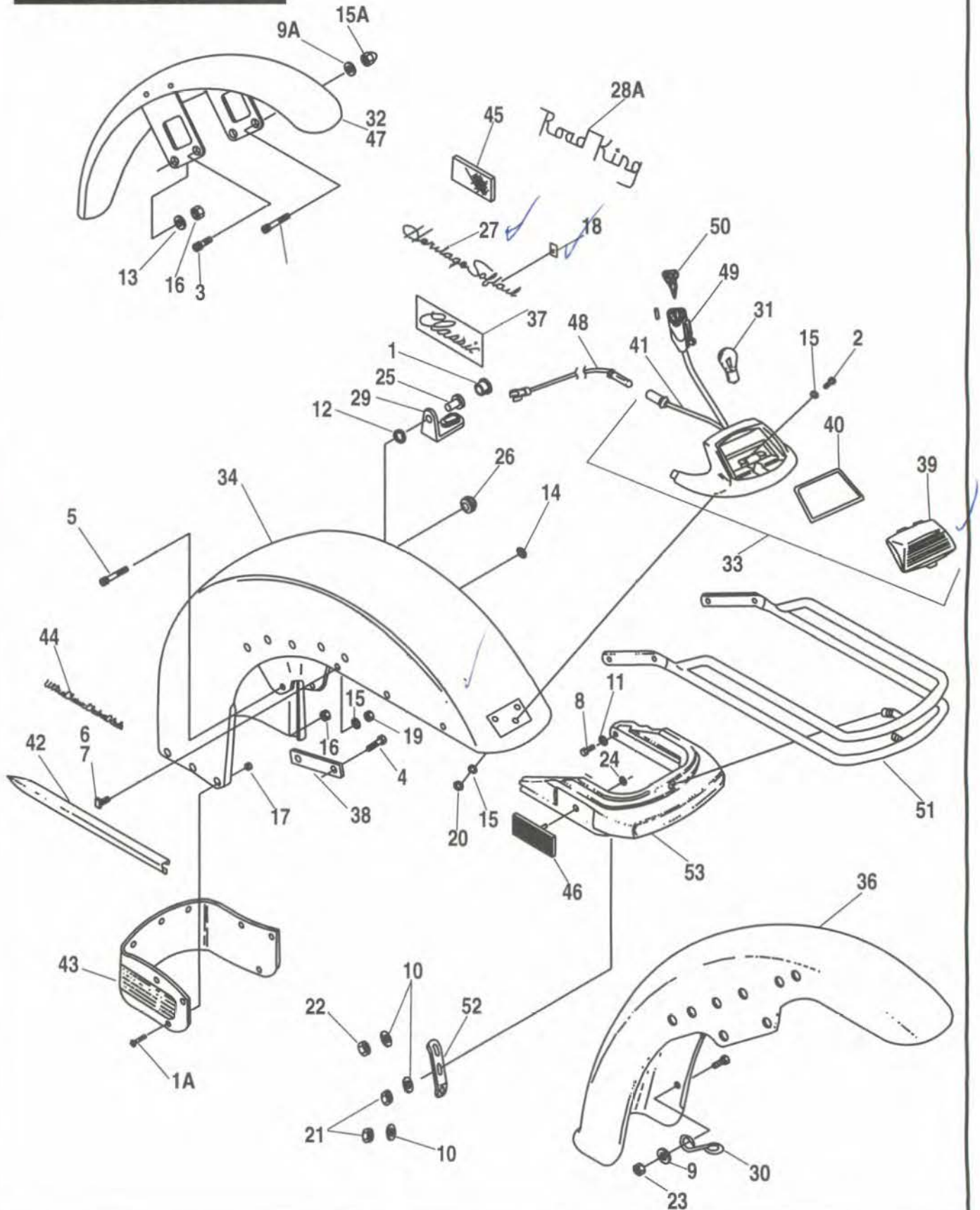

INDEX NO.	PART NO.	DESCRIPTION	FLT MODELS	FXR MODELS	SOFTAIL MODELS	DYNA MODELS
28	14159-87	DECAL, "Classic"(red) (2)	93*-DJ	--	--	--
	14331-90	DECAL, "Classic" (gold) (2)	93*-DM/P	--	--	--
	14399-94	DECAL, "Classic" (new gold)(2)	94*-DJ	--	--	--
28A	14422-94	NAMEPLATE (2)	94*-FD	--	--	--
29	38622-87	GUIDE, speedometer cable	93-ALL 94*-DJ/M/P	--	93*-BJ/N	--
30	45085-88	CABLE GUIDE	--	--	93*-BM	--
31	53439-79	BULB, fender tip lamp	93*-ALL	--	93*-BJ/N	--
32	58998-83	FENDER (prime)	--	93*-ALL	--	93*-GD/G
33	59082-79	LAMP ASSEMBLY	93-ALL	--	93*-BJ/N	--
	68706-94	LAMP ASSEMBLY	94*-ALL	--	--	--
34	59093-87	FENDER (prime)	93*-DJ;FA	--	--	--
	59094-89	FENDER (prime)	93*DM/P; 94*-FD	--	--	--
	59129-86	FENDER (prime)	--	--	93*-BJ/N	--
36	59139-89	FENDER (prime)	--	--	93*-BM	--
37	59159-80	DECAL, "Classic" (silver) (2)	93*-DJ	--	--	--
	59173-81A	DECAL, "Classic" (gold) (2)	93*-DJ	--	--	--
38	59166-80	LOCKPLATE (2)	93*-ALL	--	--	--
39	59180-80	LENS, fender lamp (amber)	93*-ALL	--	93*-BJ/N	--
40	59181-80	GASKET, fender lamp lens	93*-ALL	--	93*-BJ/N	--
41	59197-87	WIRE ASSEMBLY, fender lamp	--	--	93*-BJ/N	--
42	59211-74	SIDE TRIM (2)	93*-ALL	--	93*-BJ/N	--
43	59231-86	TRIM SKIRT, lower	93*-ALL	--	-	--
	59235-86	TRIM SKIRT, lower (black)	--	--	93*-BJ/N	--
44	59236-89	NAMEPLATE (2)	93*-DP	--	--	--
	59246-89	NAMEPLATE (2)	93*-DM	--	--	--
45	59254-91	REFLECTOR (amber) (2)	93-FA	--	--	--
46	59261-91	REFLECTOR (amber) (2)	93*-DJ/M/P	--	--	--
47	59924-80	FENDER (prime)	--	--	93*-BK	93*-GE
48	69505-89	WIRE ASSEMBLY, front fender	93-DM	--	--	--
	70196-86	WIRE ASSEMBLY, fender lamp	93-ALL	--	93*-BJ/N	--
49	72113-94BK	PLUG, 3-way socket	94*-ALL	--	--	--
50	72153-94	SOCKET LOCK, sec. 3-way	94*-ALL	--	--	--
51	91085-83B	BUMPER ASSEMBLY	93*-DJ/M/P	--	--	--
52	91090-77A	BRACKET, bumper	93*-DJ/M/P	--	--	--
53	91107-77	CUSHION, bumper	93*-DJ/M/P	--	--	--
H-D INTERNATIONAL ONLY						
33	68594-84	LAMP ASSEMBLY (HDI only)	93-ALL	--	93*-BJ	--
	68714-94	LAMP ASSEMBLY (HDI only)	94*-ALL	--	--	--
39	59182-84	LENS, fender lamp (white) (HDI only)	93*-ALL	--	93*-BJ/N	--

FLT MODELS

FLHTC
FLTC-U
FLHTC-U
FLHS
FLHR

DJ
DM
DP
FA
FD

FXR MODELS

FXR
FXRS-SP
FXLR
FXRS-CON
EA
EG
EL
EM

SOFTAIL MODELS

FLSTC
FXSTC
FXSTS
FLSTF
FLSTN
BJ
BK
BL
BM
BN

DYNA MODELS

FXDL
FXDWG
FXDS-CON
GD
GE
GG

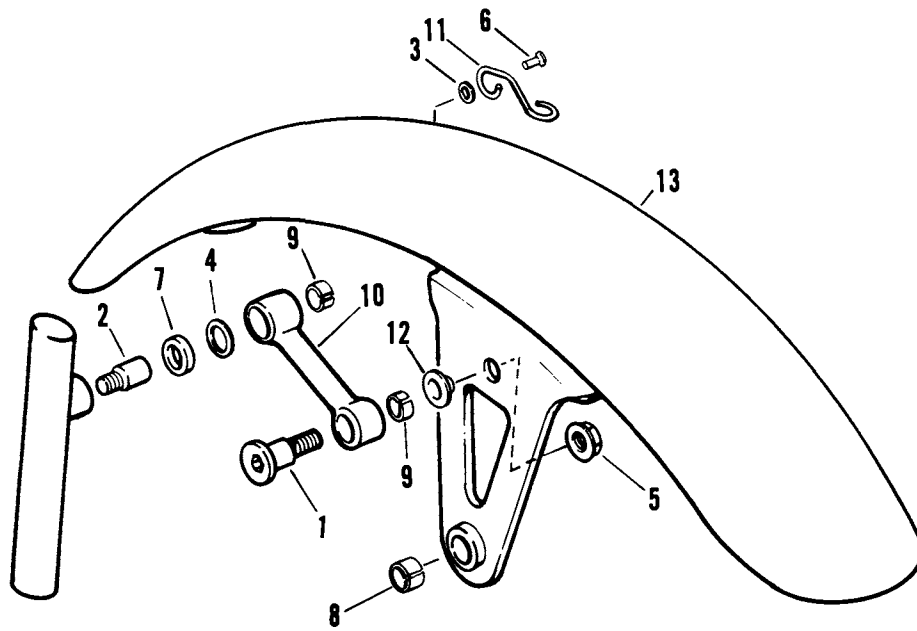

FRONT FENDER – FXSTS

INDEX NO.	PART NO.	DESCRIPTION	FLT MODELS	FXR MODELS	SOFTAIL MODELS	DYNA MODELS
NOTE: REFER TO DEALER ACESORY GUIDE FOR PAINTED PART NUMBERS.						
1	2723	SCREW shoulder (2)	--	--	93*-BL	--
2	2738	PIVOT SHAFT (2)	--	--	93*-BL	--
3	6099	WASHER	--	--	93*-BL	--
4	6409	WASHER (2)	--	--	93*-BL	--
5	7531	LOCKNUT (2)	--	--	93*-BL	--
6	8505	RIVET	--	--	93*-BL	--
7	11244	SPACER (rubber) (2)	--	--	93*-BL	--
8	33714-90	BEARING	--	--	93*-BL	--
9	33720-93	BEARING (4)	--	--	93*-BL	--
10	41042-93	PIVOT LINK (2) w/ #9	--	--	93*-BL	--
11	45085-88A	CABLE GUIDE	--	--	93*-BL	--
12	59043-93	INSERT, fender (2)	--	--	93*-BL	--
13	59176-93	FENDER (prime)	--	--	93*-BL	--

FLT MODELS

FLHTC DJ
 FLTC-U DM
 FLHTC-U DP
 FLHS FA
 FLHR FD

FXR MODELS

FXR EA
 FXRS-SP EG
 FXLR EL
 FXRS-CON EM

SOFTAIL MODELS

FLSTC BJ
 FXSTC BK
 FXSTS BL
 FLSTF BM
 FLSTN BN

DYNA MODELS

FXDL GD
 FXDWG GE
 FXDS-CON GG

REAR FENDER

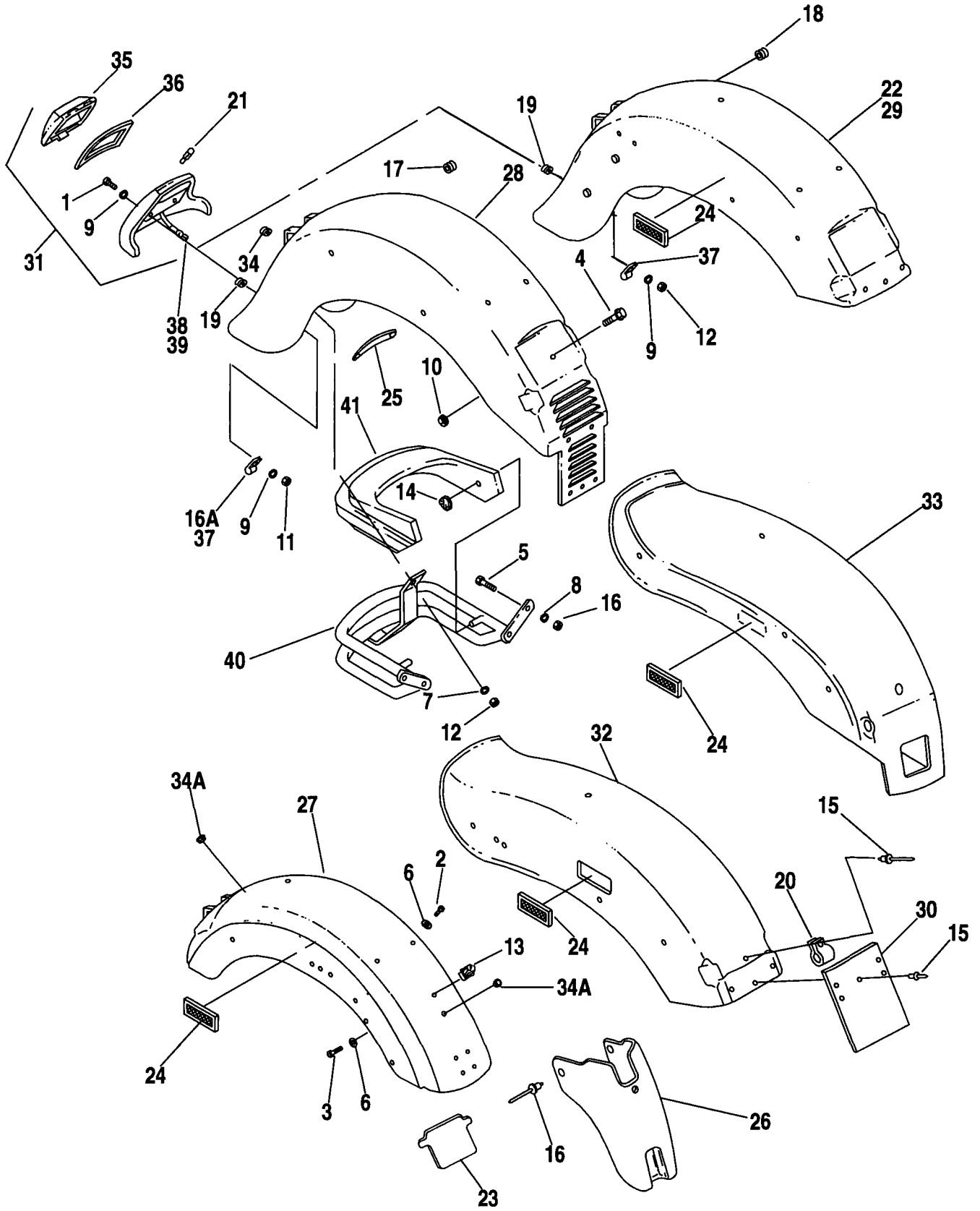

REAR FENDER

FB36B-1

INDEX NO.	PART NO.	DESCRIPTION	FLT MODELS	FXR MODELS	SOFTAIL MODELS	DYNA MODELS
NOTE: REFER TO DEALER ACCESSORY GUIDE FOR PAINTED PART NUMBERS.						
1	2604	SCREW (2)	93*-ALL	--	93*-BJ	--
2	2824W	SCREW (2)	--	93*-EA	--	--
3	3445	BOLT	--	93*-ALL	--	93*-ALL
4	3546	BOLT	93*-ALL	--	--	--
5	3987	BOLT (2)	93*-ALL	--	--	--
6	6702	WASHER (3 - FXR)	--	93*-ALL	--	93*-ALL
7	6703	WASHER	93*-ALL	--	--	--
8	7041	WASHER (2)	93*-ALL	--	--	--
9	7118	LOCKWASHER (2)	93*-ALL	--	93*-BJ	--
10	7531	LOCKNUT (3)	93*-ALL	--	--	--
11	7629	NUT (2)	93*-ALL	--	93*-BJ/N	--
12	7683	NUT	93*-ALL	--	--	--
13	8102	CAGE NUT	--	93*-ALL	--	93*-ALL
14	8135B	SPEED NUT (2)	93*-ALL	--	--	--
15	8483	POP RIVET (2)	--	--	93*-ALL	--
16	8692	RIVET (3)	--	93*-ALL	--	--
16A	10059A	CLAMP	94*-ALL	--	--	--
17	11400	GROMMET	93-ALL	--	--	93*-ALL
	67622-94	GROMMET	94*-ALL	--	--	--
18	11430	GROMMET	--	--	93*-BJ/N	--
19	11437	GROMMET	93*-ALL	--	93*-BJ/N	--
20	38712-68	CLAMP	--	--	93*-BK/L/M	--
21	53439-79	BULB, fender tip lamp	93*-ALL	--	93*-BJ/N	--
22	59126-86B	FENDER (prime)	--	--	93*-BJ/N	--
23	59150-90	PLUG, fender	--	--	--	93*-ALL
24	59255-91	REFLECTOR (red) (2)	--	--	93*-BJ/K/L/M	--
	59287-92	REFLECTOR, right (red)	--	93*-EA/G/L	93*-BN	93*-ALL
	59288-92	REFLECTOR, left (red)	--	93*-BJ/N	93*-BN	93*-ALL
25	59569-83	REINFORCEMENT	93*-ALL	--	--	--
26	59601-92	EXTENSION, fender	--	93*-ALL	--	--
27	59634-81A	FENDER (prime)	--	93*-ALL	--	--
	59634-90A	FENDER (prime)	--	--	--	93*-GD
	59655-94	FENDER (prime)	--	--	--	94*-GG
28	59579-91A	FENDER, louvered (prime)	93*-ALL	--	--	--
29	59596-89	FENDER (prime)	--	--	93*-BM	--
30	59648-84A	DEBRIS DEFLECTOR, upper	--	--	93*-ALL	--
31	59658-79	LAMP ASSEMBLY, fender tip	93*-ALL	--	93*-BJ/N	--
32	59914-86A	FENDER (prime)	--	--	93*-BK/L	--
33	59926-92	FENDER (prime)	--	--	--	93*-GE

FLT MODELS

FLHTC
FLTC-U
FLHTC-U
FLHS
FLHR

DJ
DM
DP
FA
FD

FXR MODELS

FXR
FXRS-SP
FXLR
FXRS-CON
EA
EG
EL
EM

SOFTAIL MODELS

FLSTC
FXSTC
FXSTS
FLSTF
FLSTN
BJ
BK
BL
BM
BN

DYNA MODELS

FXDL
FXDWG
FXDS-CON
GD
GE
GG

REAR FENDER

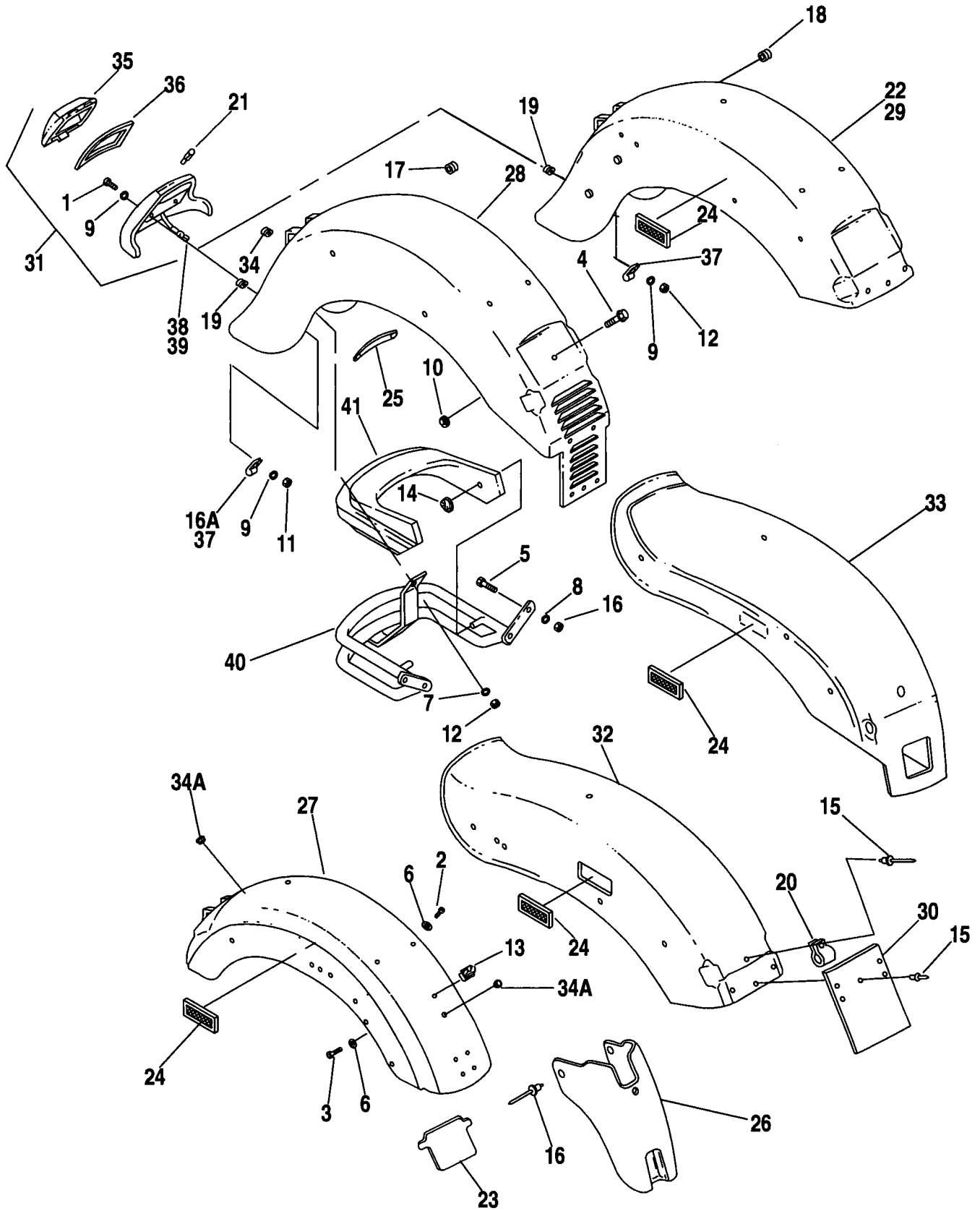

INDEX NO.	PART NO.	DESCRIPTION	FLT MODELS	FXR MODELS	SOFTAIL MODELS	DYNA MODELS
34	67070-76	GROMMET	93*-ALL	--	--	--
34A	67266-94	BUSHING (2-GG)	--	--	--	93*-ALL
35	68046-79	LENS, rear fender lamp	93*-ALL	--	93*-BJ/N	--
36	68047-79	GASKET, rear fender lamp	93*-ALL	--	93*-BJ/N	--
37	71795-63A	CLAMP	93*-ALL	--	93*-BJ/N	--
38	72118-94BK	PLUG, 8-way socket	94*-ALL	--	--	--
39	72158-94	SOCKET LOCK, sec. 8-way				
	91013-79	REAR BUMPER ASSEMBLY w/ #14, 40 & 41	93*-ALL	--	--	--
40	91023-79	RAIL, rear bumper	93*-ALL	--	--	--
41	91123-77	BUMPER CUSHION, rear	93*-ALL	--	--	--
H-D INTERNATIONAL ONLY						
	59251-90	REFLECTOR ASM., rear (red) w/ 59259-90	93*-ALL	--	93*-BJ/M/N	93*-GD/G
24	59254-91	REFLECTOR (amber) (2)	--	93*-EA/G/L	93*-BL/M	--
	59259-90	REFLECTOR, red	93*-ALL	--	93*-BJ/M/N	93*-ALL
	59289-92	REFLECTOR, right, (amber)	--	93*-EA/G/L	93*-BN	93*-ALL
	59290-92	REFLECTOR, left, (amber)	--	93*-EA/G/L	93*-BN	93*-ALL
31	68785-94	LAMP ASSEMBLY, fender tip (HDI only)	94*-FD	--	--	--

FLT MODELS

FLHTC DJ
 FLTC-U DM
 FLHTC-U DP
 FLHS FA
 FLHR FD

FXR MODELS

FXR EA
 FXRS-SP EG
 FXLR EL
 FXRS-CON EM

SOFTAIL MODELS

FLSTC BJ
 FXSTC BK
 FXSTS BL
 FLSTF BM
 FLSTN BN

DYNA MODELS

FXDL GD
 FXDWG GE
 FXDS-CON GG

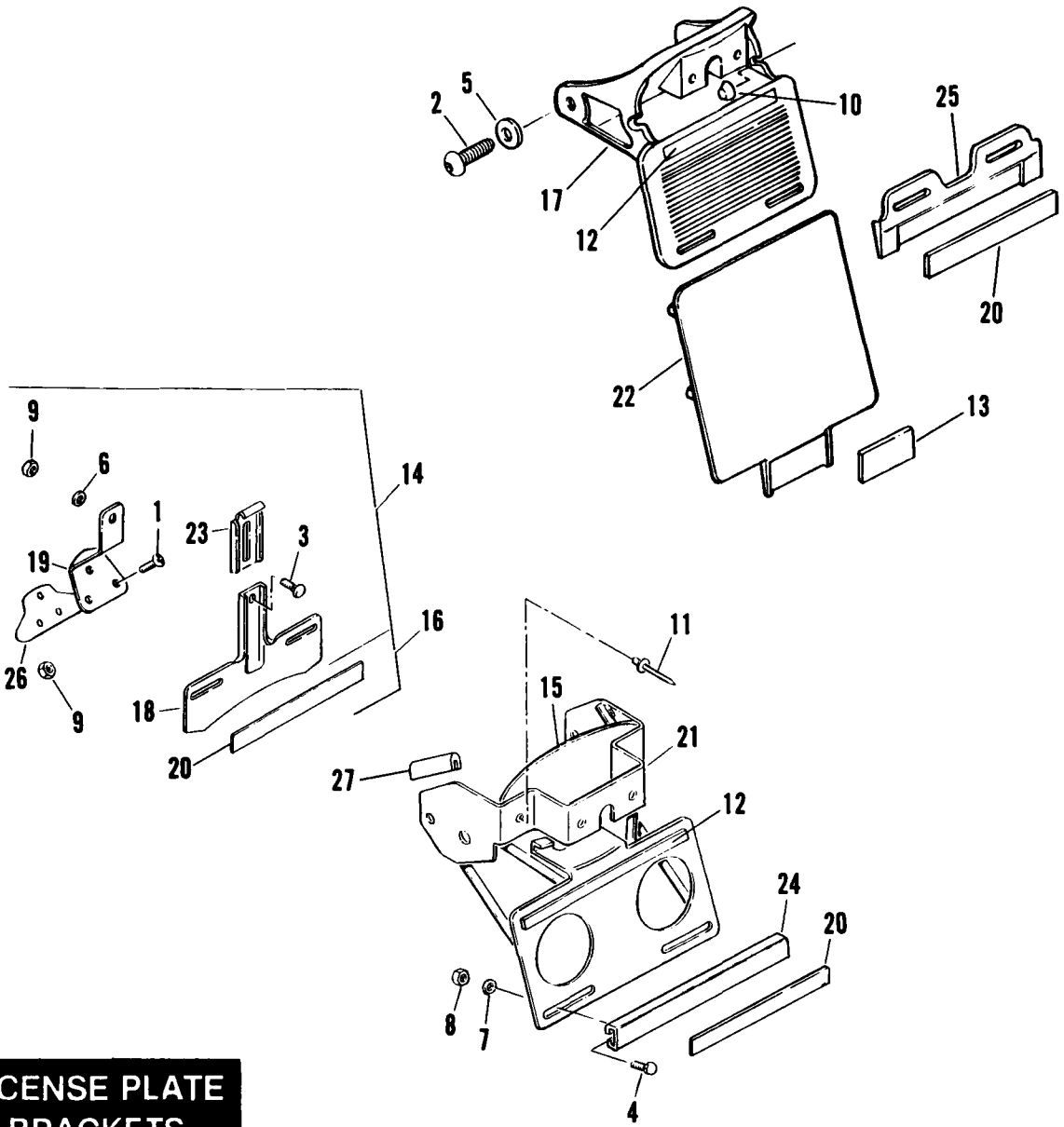

LICENSE PLATE BRACKETS

INDEX NO.	PART NO.	DESCRIPTION	FLT MODELS	FXR MODELS	SOFTAIL MODELS	DYNA MODELS
1	2773	SCREW (3; 1 - EM)	--	93*-ALL	93*-BJ/M/N	93*-GD/G
2	4098	SCREW (2)	--	--	--	93*-GE
3	5403B	BOLT	--	93*-ALL	93*-BJ/M/N	93*-GD/G
4	5465	CARRIAGE BOLT (2)	--	--	93*-BK/L	--
5	6379W	WASHER (2)	--	--	--	93*-GE
6	6703	WASHER	--	93*-ALL	93*-BJ/M/N	93*-GD/G
7	6716	WASHER (2)	--	--	93*-BK/L	--
8	7624	NUT (2)	--	--	93*-BK/L	--
9	7792	NUT (4)	--	93*-ALL	93*-BJ/M/N	93*-GD/G
10	7869	PUSH CAP (2)	--	--	--	93*-GE
11	8483	POP RIVET (2)	--	--	93*-BK/L	--
12	52092-77	FOAM TAPE	--	--	93*-BK/L	93*-GE
14	59626-84	LICENSE PLATE BRACKET ASM.	--	93*-EA/G/L	93*-BJ/M/N	93*-GD/G
15	59971-80	SPLASH SHIELD (rubber)	--	--	93*-BK/L	--
16	59983-75	LICENSE PLATE BRACKET ASM. w/ #14 & 20	--	93*-EA/G/L	93*-BJ/M/N	93*-GD/G
	60004-89	LICENSE PLATE BRACKET ASM. (chrome)	--	93*-EM	--	--
17	59979-93	LICENSE PLATE BRACKET ASM.	--	--	--	93*-GE
18	59984-73	BRACKET	--	93*-ALL	93*-BJ/M/N	93*-GD/G
19	59986-75	SUPPORT	--	93*-ALL	93*-BJ/M/N	93*-GD/G
20	59988-72	REFLECTOR	93*-ALL	93*-ALL	93*-ALL	93*-ALL
21	59993-80A	LICENSE PLATE BRACKET ASM.	--	--	93*-BK/L	--
23	60001-55	CLAMP	--	93*-ALL	93*-BJ/M/N	93*-GD/G
24	60005-77	CLAMP	--	--	93*-BK/L	--
25	60019-93	REFLECTOR BRACKET	--	--	--	93*-GE
26	68456-89	PAD	--	93*-EM	--	--
27	71309-92	MOULDING (2)	--	--	93*-BK/L	--
H-D INTERNATIONAL ONLY						
	59262-90	REFLECTOR, rear (red) (HDI only)	--	--	93*-BK/L	--
13	59259-90	REFLECTOR, rear (red) (HDI only)	--	--	--	93*-GE
22	59994-93	LICENSE PLATE BRACKET (HDI only)	--	--	--	93*-GE

FLT MODELS

FLHTC DJ
 FLTC-U DM
 FLHTC-U DP
 FLHS FA
 FLHR FD

FXR MODELS

FXR EA
 FXRS-SP EG
 FXLR EL
 FXRS-CON EM

SOFTAIL MODELS

FLSTC BJ
 FXSTC BK
 FXSTS BL
 FXSTF BM
 FLSTN BN

DYNA MODELS

FXDL GD
 FXDWG GE
 FXDS-CON GG

REAR FENDER SUPPORTS

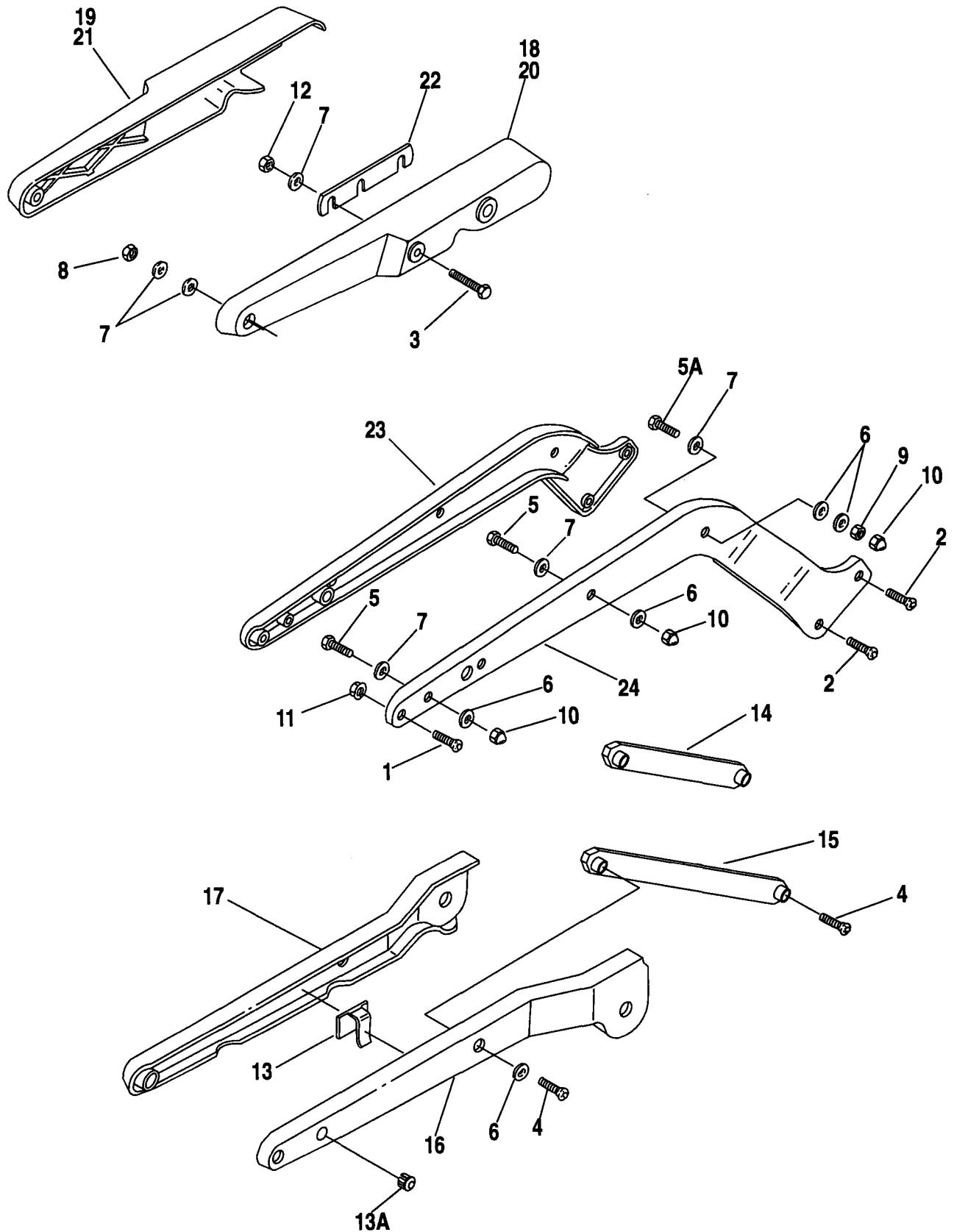

INDEX NO.	PART NO.	DESCRIPTION	FLT MODELS	FXR MODELS	SOFTAIL MODELS	DYNA MODELS
1	2005	SCREW (2)	--	--	93*-ALL	--
2	4013	SCREW (4)	--	--	93*-ALL	--
3	4046	SCREW (2)	--	93*-ALL	--	--
4	4098	SCREW (4 - GD; 6 - GE;2-GG)	--	--	--	93*-ALL
5	4716W	BOLT (6; 4 - BJ/M)	--	--	93*-BK/L/M/N--	--
5A	4721	BOLT (2)	--	--	93*-BJ/M	--
6	6379W	WASHER (6 - BK/L/M; 4-BJ; 2 - BN & Dyna)	--	--	93*-ALL	93*-ALL
7	6701	WASHER (2 - FXR, BJ/N; 4 - BK/L)	--	93*-EA/G/L	93*-ALL	--
8	7628	LOCKNUT (2)	--	93*-ALL	--	--
9	7643W	NUT (2)	--	--	93*-BJ/M	--
10	7680W	ACORN NUT (2-BJ/N; 4-BM; 6-BK/L	--	--	93*-ALL	--
11	7775	NUT (2)	--	--	93*-BJ/M/N	--
12	7628	NUT, flange (2)	--	93*-ALL	--	--
13	10102	CLIP (2)	--	--	--	93*-ALL
13A	56239-93	HOLE PLUG (2)	--	--	--	94*-GG
14	59112-90	STRUT, left	--	--	--	93*-ALL
15	59113-90	STRUT, right	--	--	--	93*-ALL
16	59136-94	SUPPORT, right	--	--	--	93*-GG
	59138-93	SUPPORT, right	--	--	--	93*-GD
	59893-93	SUPPORT, right	--	--	--	93*-GE
17	59167-94	SUPPORT, left	--	--	--	93*-GG
	59171-93	SUPPORT, left	--	--	--	93*-GD
	60007-93	SUPPORT, left	--	--	--	93*-GE
18	59542-87	SUPPORT, right (chrome)	--	93*-EG/L/M	--	--
19	59544-87	SUPPORT, left (chrome)	--	93*-EG/L/M	--	--
20	59548-87	SUPPORT, right	--	93*-EA	--	--
21	59558-87	SUPPORT, left	--	93*-EA	--	--
22	59591-87	SPACER (2)	--	93*-EA/G/M	--	--
23	59954-86A	SUPPORT, left (chrome)	--	--	93*-BK/L	--
	59969-86A	SUPPORT, left (chrome)	--	--	93*-BJ/M/N	--
24	59955-86A	SUPPORT, right (chrome)	--	--	93*-BK/L	--
	59964-86A	SUPPORT, right (chrome)	--	--	93*-BJ/M/N	--
H-D INTERNATIONAL ONLY						
24	59964-86A	SUPPORT, right (chrome)	--	--	93*-ALL	--
23	59969-86A	SUPPORT, left (chrome)	--	--	93*-ALL	--

FLT MODELS

FLHTC DJ
 FLTC-U DM
 FLHTC-U DP
 FLHS FA
 FLHR FD

FXR MODELS

FXR EA
 FXRS-SP EG
 FXLR EL
 FXRS-CON EM

SOFTAIL MODELS

FLSTC BJ
 FXSTC BK
 FXSTS BL
 FLSTF BM
 FLSTN BN

DYNA MODELS

FXDL GD
 FXDWG GE
 FXDS-CON GG

PRIMARY HOUSING

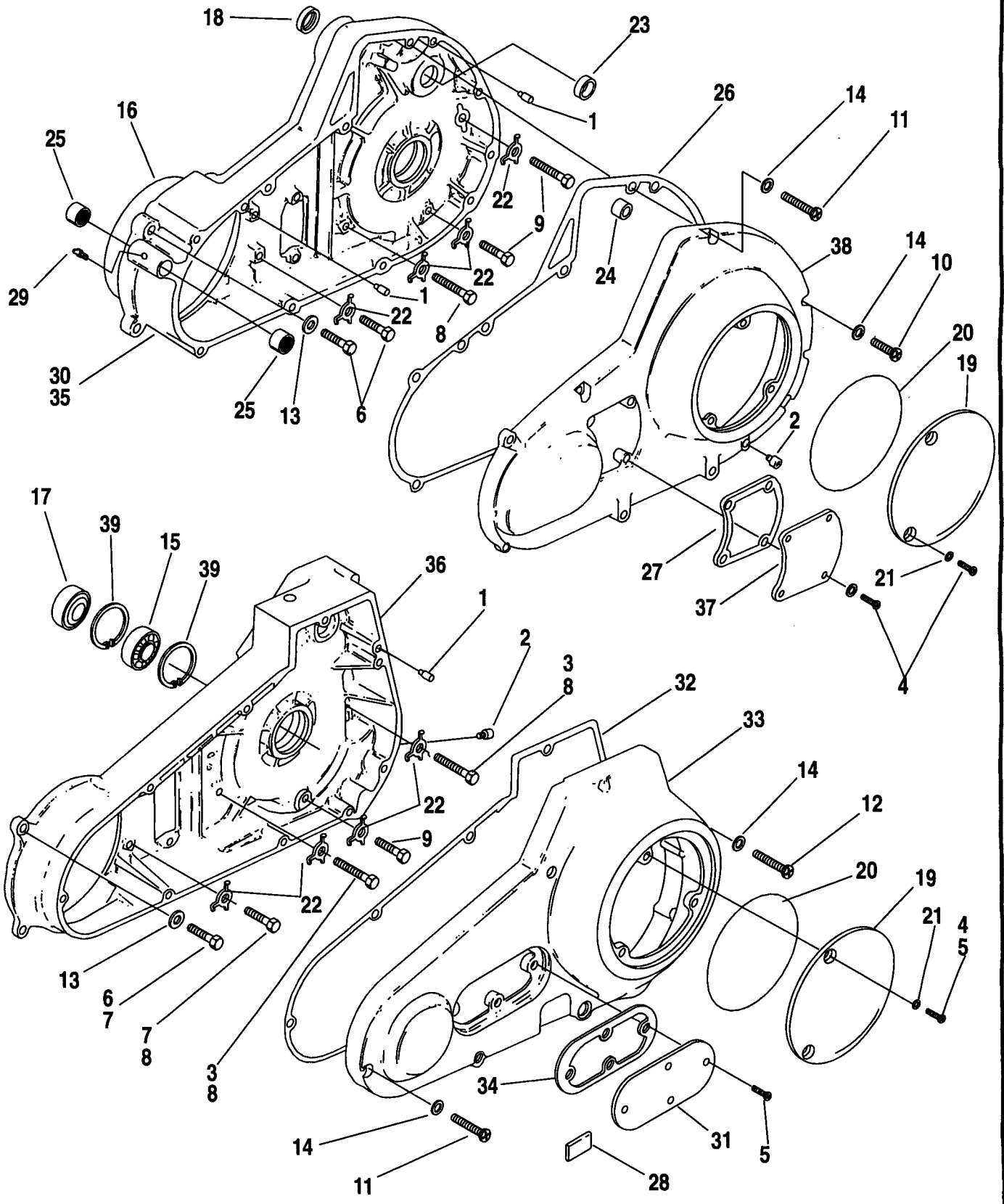

INDEX NO.	PART NO.	DESCRIPTION	FLT MODELS	FXR MODELS	SOFTAIL MODELS	DYNA MODELS
1	221	PIN (2)	93*-ALL	93*-ALL	--	--
	375	PIN (2 - Dyna)	--	--	93*-ALL	93*-ALL
2	739A	PLUG, magnetic	93*-ALL	93*-ALL	93*-ALL	93*-ALL
3	858	SCREW (2-Dyna; 4-Softail)	--	--	94*-ALL	94*-ALL
4	940	SCREW (7; 3 - Softail & Dyna)	93*-ALL	93*-ALL	93*-ALL	93*-ALL
5	941	SCREW (4; 7-1994 & later Dyna)	--	--	93*-ALL	93*-ALL
6	2818	SCREW (2-1993 Dyna; 4)	93*-ALL	93*-ALL	94*-ALL	94*-ALL
7	2871W	BOLT (4)	--	--	93*-ALL	--
8	4068	BOLT (4 - Softail & Dyna)	93*-ALL	--	93*-ALL	93*-ALL
9	4086	BOLT (2 - FLT)	93*-ALL	93*-ALL	--	93*-ALL
10	4718A	SCREW w/ washer (5)	93*-ALL	93*-ALL	--	--
11	4740A	SCREW (5; 7 - Softail & Dyna)	93*-ALL	93*-ALL	93*-ALL	93*-ALL
12	4820A	BOLT (5)	--	--	93*-ALL	93*-ALL
13	6016	WASHER (2)	93*-ALL	93*-ALL	93*-ALL	93*-ALL
14	6099	WASHER (5; 7 - Softail & Dyna)	93*-ALL	93*-ALL	93*-ALL	93*-ALL
15	9135	BEARING	93*-ALL	93*-ALL	93*-ALL	93*-ALL
16	11147	O-RING, housing cover	93*-ALL	93*-ALL	93*-ALL	93*-ALL
17	12052	OIL SEAL	93*-ALL	93*-ALL	93*-ALL	93*-ALL
18	12053A	OIL SEAL	93-ALL	93-ALL	93-ALL	93-ALL
	12066	OIL SEAL	94*-ALL	94*-ALL	94*-ALL	94*-ALL
19	25414-70A	COVER, clutch	93-FA	93*-EA	--	--
	60668-84B	COVER, clutch (chrome)	93-DJ/M/P; 94*-ALL	93*-EG/L/M	93*-ALL	93*-ALL
20	25416-84	O-RING, clutch cover	93*-ALL	93*-ALL	93*-ALL	93*-ALL
21	31433-84A	WASHER (nylon) (3)	93*-ALL	93*-ALL	93*-ALL	93*-ALL
22	33318-85	LOCKING TAB (4 - FXR; 5; 6 - Softail)	93*-ALL	93*-ALL	93*-ALL	93*-ALL
23	33445-89	BUSHING	93-ALL	93-ALL	93-ALL	93-ALL
	33445-94	BUSHING	94*-ALL	94*-ALL	94*-ALL	94*-ALL
24	33446-89	BUSHING	93-ALL	93-ALL	93-ALL	93-ALL
	33446-94	BUSHING	94*-ALL	94*-ALL	94*-ALL	94*-ALL
25	33713-85	BUSHING (2)	93*-ALL	--	--	--
26	34901-85	GASKET, cover	93-ALL	93-ALL	--	--
	34901-94	GASKET, cover	94*-ALL	94*-ALL	--	--
27	34906-85A	GASKET, inspection cover	93*-ALL	93*-ALL	--	--
28	50100-70	BUMPER, jiffy stand	--	--	93*-ALL	--
29	50972-75	FITTING, lubrication	93*-ALL	--	--	--
30	60432-93	PRIMARY HOUSING ASM. (black wrinkle)	93-DJ/M/P	--	--	--
	60432-94	PRIMARY HOUSING ASM. (black wrinkle)	94*-ALL	--	--	--
31	60529-90	COVER, inspection (chrome)	--	--	--	93*-GD/G
	60572-86	COVER, inspection (chrome)	--	--	93*-ALL	93*-GE
32	60539-89A	GASKET, primary cover	--	--	93-ALL	93-ALL
	60539-94	GASKET, primary cover	--	--	94*-ALL	94*-ALL
33	60543-89	COVER ASSEMBLY, primary (chrome)	--	--	93-ALL	93-ALL
	60543-94	COVER ASSEMBLY, primary (chrome)	--	--	94*-ALL	94*-ALL
34	60567-90A	GASKET, inspection cover	--	--	93*-ALL	93*-ALL

FLT MODELS

FLHTC DJ
 FLTC-U DM
 FLHTC-U DP
 FLHS FA
 FLHR FD

FXR MODELS

FXR EA
 FXRS-SP EG
 FXLR EL
 FXRS-CON EM

SOFTAIL MODELS

FLSTC BJ
 FXSTC BK
 FXSTS BL
 FLSTF BM
 FLSTN BN

DYNA MODELS

FXDL GD
 FXDWG GE
 FXDS-CON GG

PRIMARY HOUSING

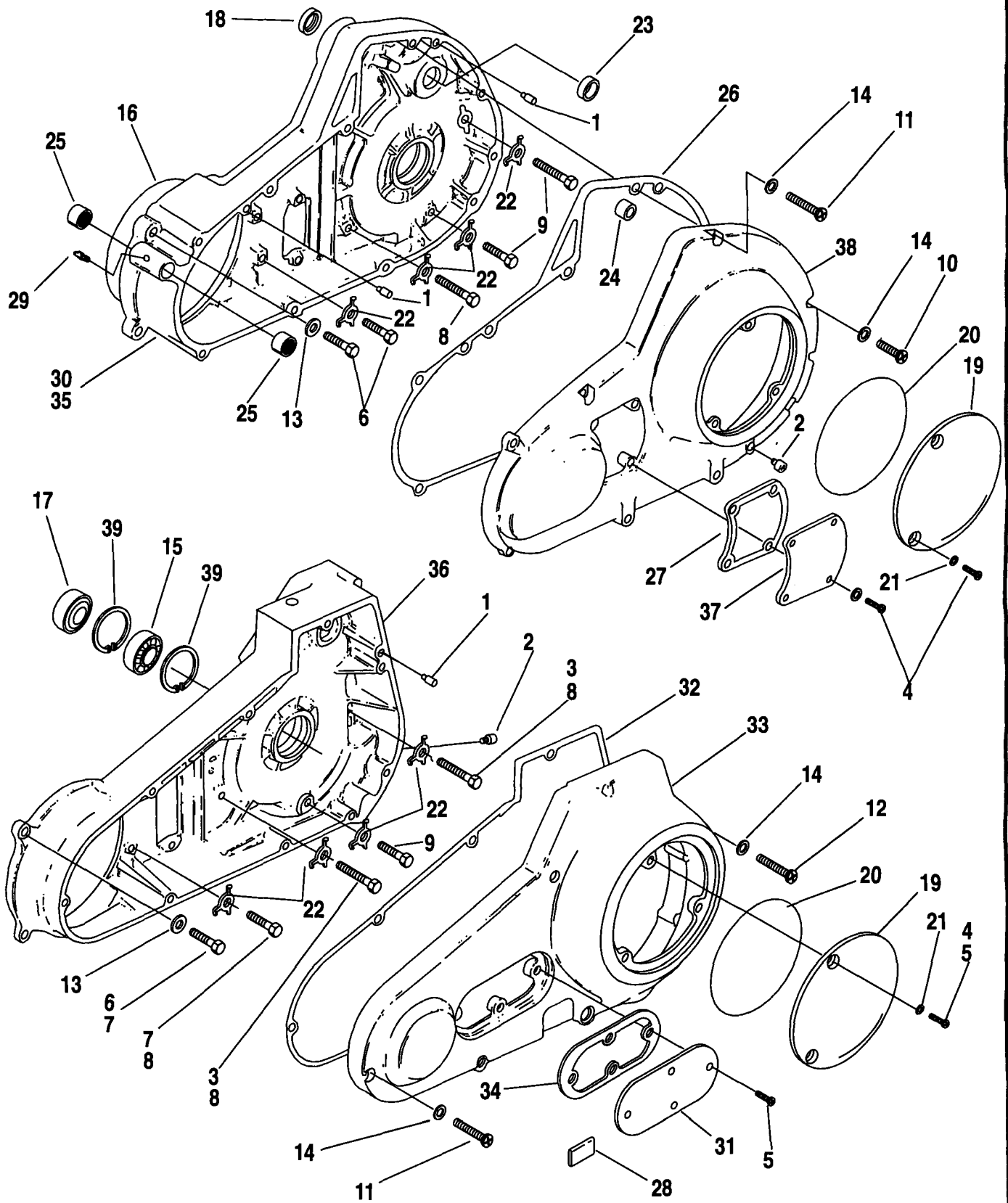

INDEX NO.	PART NO.	DESCRIPTION	FLT MODELS	FXR MODELS	SOFTAIL MODELS	DYNA MODELS
35	60612-90	PRIMARY HOUSING ASM. (black wrinkle)	--	93-EG/L/M	--	--
	60612-94	PRIMARY HOUSING ASM. (black wrinkle)	--	94*-EL	--	--
	60661-93	PRIMARY HOUSING ASM.	93-FA	--	--	--
	60662-92	PRIMARY HOUSING ASM.	--	93-EA	--	--
	60662-94	PRIMARY HOUSING ASM.	--	94*-EA	--	--
36	60616-90	PRIMARY HOUSING ASM. (black wrinkle)	--	--	--	93-GD
	60616-94	PRIMARY HOUSING ASM.(black wrinkle)	--	--	--	94*-GD/G
	60617-93	PRIMARY HOUSING ASM. (black wrinkle)	--	--	--	93-GE
	60617-94	PRIMARY HOUSING ASM.(black wrinkle)	--	--	--	94*-GE
	60630-90	PRIMARY HOUSING ASM. (black wrinkle)	--	--	93-ALL	--
	60630-94	PRIMARY HOUSING ASM. (black wrinkle)	--	--	94*-ALL	--
37	60642-85A	COVER, inspection	--	93*-EA	--	--
	60667-85A	COVER, inspection (chrome)	--	93*-EG/L/M	--	--
	60670-85	COVER, inspection (chrome)	93-DJ/M/P; 94*-ALL	--	--	--
	60673-85	COVER, inspection	93-FA	--	--	--
38	60664-89	COVER ASSEMBLY, primary	93-FA	93-EA	--	--
	60664-94	COVER ASSEMBLY, primary	--	94*-EA	--	--
	60665-89	COVER ASSEMBLY, primary (chrome)	93-DJ/M/P	93-EG/L/M	--	--
	60665-94	COVER ASSEMBLY, primary (chrome)	94*-ALL	94*-EL	--	--
39	60678-85	RETAINING RING (2)	93*-ALL	93*-ALL	93*-ALL	93*-ALL

FLT MODELS

FLHTC DJ
 FLTC-U DM
 FLHTC-U DP
 FLHS FA
 FLHR FD

FXR MODELS

FXR EA
 FXRS-SP EG
 FXLR EL
 FXRS-CON EM

SOFTAIL MODELS

FLSTC BJ
 FXSTC BK
 FXSTS BL
 FLSTF BM
 FLSTN BN

DYNA MODELS

FXDL GD
 FXDWG GE
 FXDS-CON GG

FUEL TANK - FLT

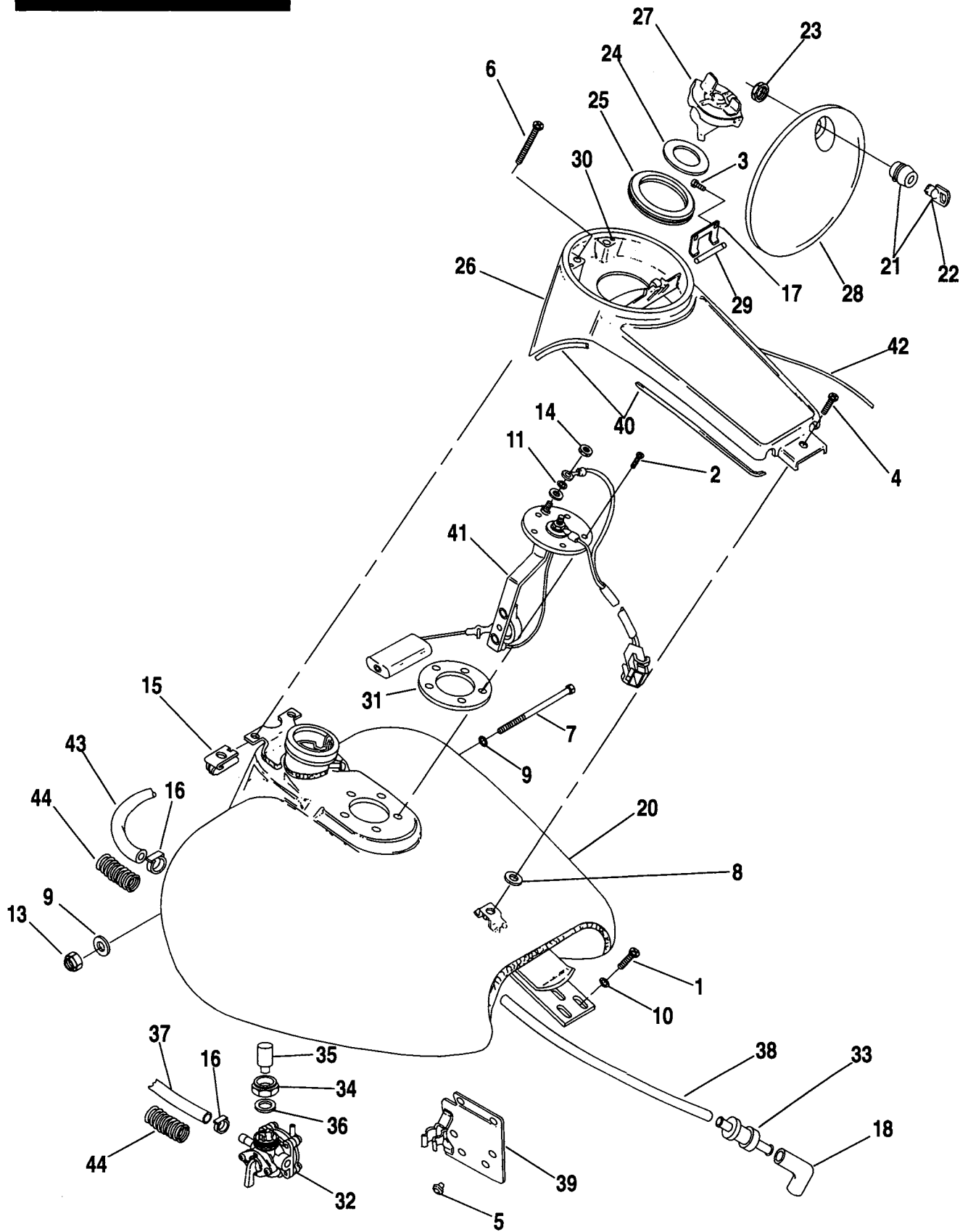

INDEX NO.	PART NO.	DESCRIPTION	FLT MODELS	FXR MODELS	SOFTAIL MODELS	DYNA MODELS
NOTE: REFER TO DEALER ACCESSORY GUIDE FOR PAINTED PART NUMBERS.						
1	939	SCREW (2)	93-ALL; 94*-DJ/M/P	--	--	--
2	1309B	SCREW, sealing (5)	93-ALL; 94*-DJ/M/P	--	--	--
3	3529	SCREW (2)	93-ALL; 94*-DJ/M/P	--	--	--
4	3652	SCREW	93-ALL; 94*-DJ/M/P	--	--	--
5	3739	SCREW (2)	93-ALL; 94*-DJ/M/P	--	--	--
6	4033	SCREW (2)	93-ALL; 94*-DJ/M/P	--	--	--
7	4061	SCREW	93-ALL; 94*-DJ/M/P	--	--	--
8	6109	WASHER	93-ALL; 94*-DJ/M/P	--	--	--
9	6702	WASHER (2)	93-ALL; 94*-DJ/M/P	--	--	--
10	6703	WASHER (2)	93-ALL; 94*-DJ/M/P	--	--	--
11	7069	LOCKWASHER	93-ALL; 94*-DJ/M/P	--	--	--
13	7531	LOCKNUT	93-ALL; 94*-DJ/M/P	--	--	--
14	7638	NUT, (brass)	93-ALL; 94*-DJ/M/P	--	--	--
15	7743	CLIP NUT (2)	93-ALL; 94*-DJ/M/P	--	--	--
16	10014	CLAMP (4)	93-ALL; 94*-DJ/M/P	--	--	--
17	10105	CLIP	93-ALL; 94*-DJ/M/P	--	--	--
18	27097-92	HOSE, vent	93-ALL; 94*-DJ/M/P	--	--	--
	53560-93	LOCK SET, complete vehicle	93-FA	--	--	--
	53574-93	LOCK SET, complete vehicle	93*-DJ/P	--	--	--
	53575-93	LOCK SET, complete vehicle	93*-DM	--	--	--
20	61227-92	FUEL TANK (prime)	93-ALL 94*-DJ/M/P	--	--	--
21	61029-92	LOCK, door w/ keys	93-ALL; 94*-DJ/M/P	--	--	--
22	71452-91A	KEYSET (specify key code no.)	93-ALL; 94*-DJ/M/P	--	--	--

FLT MODELS

FLHTC
FLTC-U
FLHTC-U
FLHS
FLHR

DJ
DM
DP
FA
FD

FXR MODELS

FXR
FXRS-SP
FXLR
FXRS-CON

EA
EG
EL
EM

SOFTAIL MODELS

FLSTC
FXSTC
FXSTS
FLSTF
FLSTN

BJ
BK
BL
BM
BN

DYNA MODELS

FXDL
FXDWG
FXDS-CON

GD
GE
GG

FUEL TANK - FLT

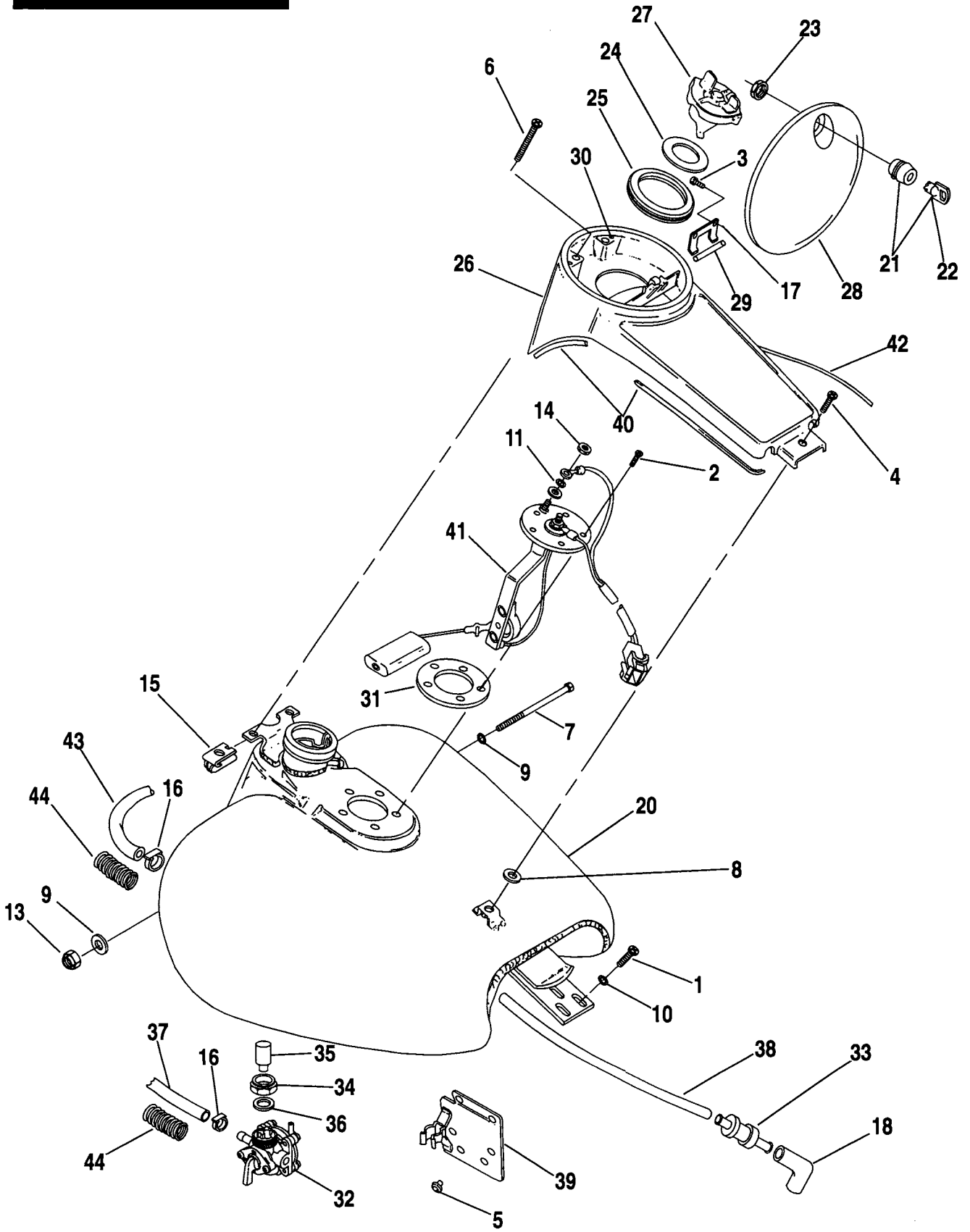

INDEX NO.	PART NO.	DESCRIPTION	FLT MODELS	FXR MODELS	SOFTAIL MODELS	DYNA MODELS	
23	84850-92	NUT, lock	93-ALL; 94*-DJ/M/P	--	--	--	
24	61109-85C	GASKET, filler cap	93-ALL; 94*-DJ/M/P	--	--	--	
25	61112-82A	BOOT	93-ALL; 94*-DJ/M/P	--	--	--	
26	61270-88A	CONSOLE	93-ALL; 94*-DJ/M/P	--	--	--	
27	61274-92	FILLER CAP, vac. vent	93-ALL; 94*-DJ/M/P	--	--	--	
28	61278-92	DOOR, console	93-ALL; 94*-DJ/M/P	--	--	--	
29	61279-88	HINGE PIN	93-ALL; 94*-DJ/M/P	--	--	--	
30	61313-88	BUMPER, cover (2)	93-ALL; 94*-DJ/M/P	--	--	--	
31	61322-80B	GASKET, fuel sending unit	93-ALL; 94*-DJ/M/P	--	--	--	
32	61338-82	FUEL VALVE BODY	93-ALL; 94*-DJ/M/P	--	--	--	
	61338-94	FUEL VALVE BODY	94-ALL; 94*-DJ/M/P	--	--	--	
33	62150-85	VAPOR VALVE	93-ALL; 94*-DJ/M/P	--	--	--	
34	62161-75	NUT, fuel valve	93-ALL; 94*-DJ/M/P	--	--	--	
35	62170-81A	FILTER, fuel valve	93-ALL; 94*-DJ/M/P	--	--	--	
36	62172-75	GASKET, fuel valve	93-ALL; 94*-DJ/M/P	--	--	--	
37	62356-92	HOSE, fuel	93-ALL; 94*-DJ/M/P	--	--	--	
38	63591-93	TUBE, tank to valve	93-ALL; 94*-DJ/M/P	--	--	--	
39	70995-93	BRACKET, valve mtg.	93-ALL; 94*-DJ/M/P	--	--	--	
40	71294-89	MOLDING, (rubber)	93-ALL; 94*-DJ/M/P	--	--	--	
41	75040-88	SENDING UNIT, fuel gauge	93-ALL; 94*-DJ/M/P	--	--	--	
		NOTE: Hose or insulator is sold in bulk length under the following part numbers. Cut to length.					
42	27138-90	HOSE, 3/16" I.D. x 11/32" O.D. (rubber)(10' lg.)	93-ALL; 94*-DJ/M/P	--	--	--	
43	63501-68	HOSE, 1/4" I.D. x 5/8" O.D. (rubber)(25' lg.)	93-ALL; 94*-DJ/M/P	--	--	--	
44	63504-84	INSULATOR, 1/2" I.D. (NYLON) (8' lg.)	93-ALL; 94*-DJ/M/P	--	--	--	

FLT MODELS
 FLHTC DJ
 FLTC-U DM
 FLHTC-U DP
 FLHS FA
 FLHR FD

FXR MODELS
 FXR EA
 FXRS-SP EG
 FXLR EL
 FXRS-CON EM

SOFTAIL MODELS
 FLSTC BJ
 FXSTC BK
 FXSTS BL
 FLSTF BM
 FLSTN BN

DYNA MODELS
 FXDL GD
 FXDWG GE
 FXDS-CON GG

FUEL TANKS — FXR

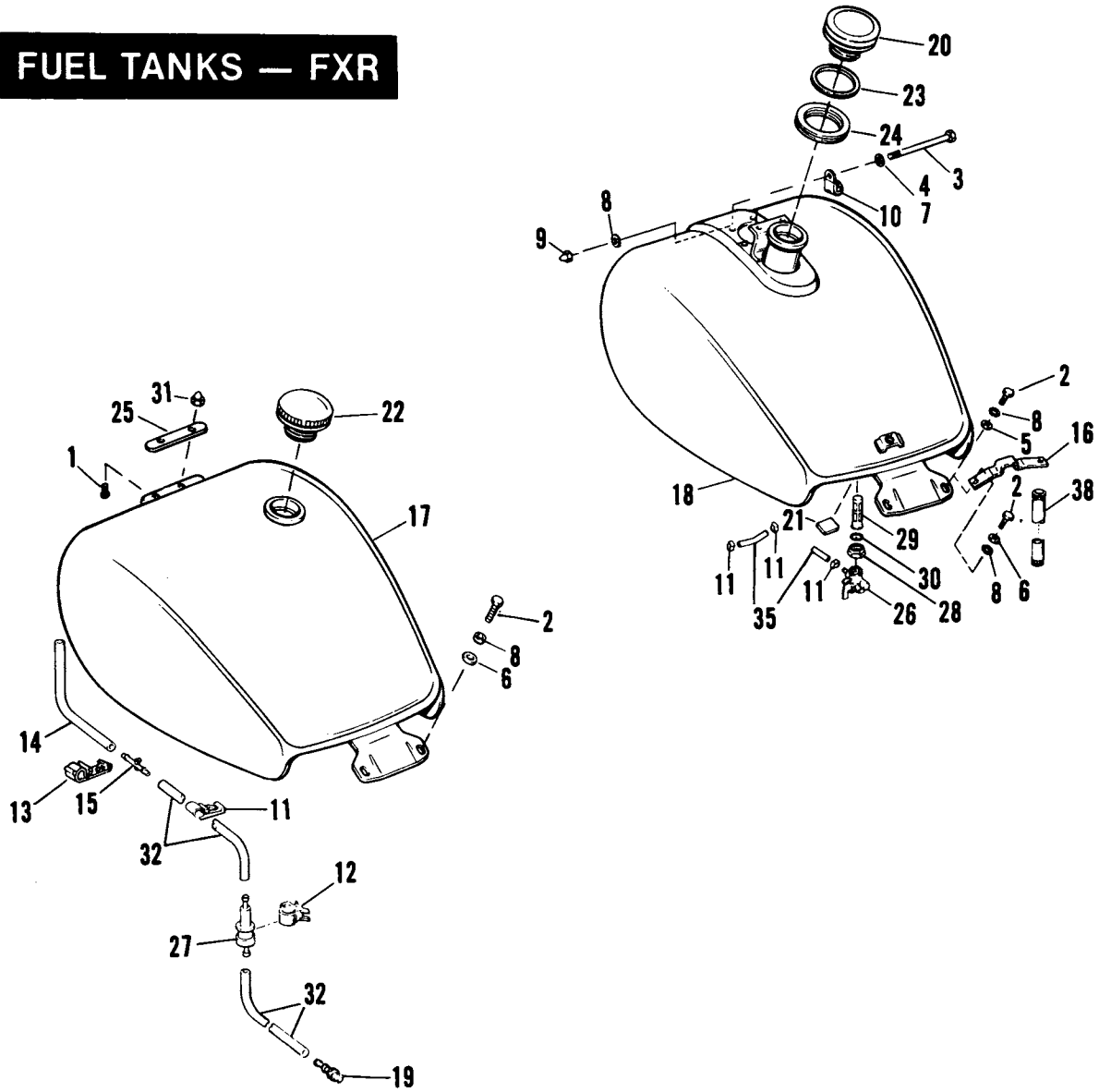

INDEX NO.	PART NO.	DESCRIPTION	FLT MODELS	FXR MODELS	SOFTAIL MODELS	DYNA MODELS
NOTE: REFER TO DEALER ACCESSORY GUIDE FOR PAINTED PART NUMBERS.						
1	2665	SCREW (2)	--	93*-EL	--	--
2	4017	BOLT (2)	--	93*-ALL	--	--
3	4100HW	BOLT	--	93*-ALL	--	--
4	6019	WASHER	--	93*-EL	--	--
5	6109	WASHER (2)	--	93*-EA	--	--
6	6237	WASHER (2)	--	93*-EG/L/M	--	--
7	6702	WASHER	--	93*-ALL	--	--
8	7232	LOCKWASHER (2)	--	93*-ALL	--	--
9	7507	ACORN NUT (chrome)	--	93*-ALL	--	--
10	9988	CLIP, throttle cables	--	93*-ALL	--	--
11	10014	CLAMP, (4)	--	93*-ALL	--	--
12	10108	CLIP, vapor valve (2)	--	93*-ALL	--	--
13	10114	CLIP, vapor valve hose	--	93*-EA/G/M	--	--
14	27120-92	HOSE, tank to conn.	--	93*-EL	--	--
	27198-92	HOSE, tank to conn.	--	93*-EA/G/M	--	--
15	27196-92	CONNECTOR, vent	--	93*-ALL	--	--
16	52107-86	BRACKET, seat	--	93*-EA	--	--
17	61006-92	FUEL TANK (prime)	--	93*-EL	--	--
18	61265-92	FUEL TANK (prime)	--	93*-EA/G/M	--	--
19	61131-92	CONNECTOR, vent line	--	93*-ALL	--	--
20	61273-92	FILLER CAP, vac. vent	--	93*-EA/G/M	--	--
21	61079-82	PAD	--	93*-ALL	--	--
22	61272-92A	FILLER CAP, vac. vent	--	93-EL; 94*-ALL	--	--
23	61109-85C	GASKET, filler cap	--	93*-EA/G/M	--	--
24	61112-82A	BOOT	--	93*-EA/G/M	--	--
25	61137-87	BRACKET, trim strap	--	93*-EL	--	--
26	61335-83	VALVE, body	--	93*-ALL	--	--
27	62150-85	VAPOR VALVE	--	93*-ALL	--	--
28	62161-75	NUT	--	93*-ALL	--	--
29	62166-81A	FILTER	--	93*-ALL	--	--
30	62172-75	GASKET, fuel filter	--	93*-ALL	--	--
31	90844-80	ACORN NUT (2)	--	93*-ALL	--	--
NOTE: Hose or insulator is sold in bulk length under the following part numbers. Cut to length.						
32	27138-90	HOSE 3/16" I.D. x 11/32" O.D. (rubber) (10 ft. lg.)	--	93*-ALL	--	--
34	63501-68	HOSE, 1/4" I.D. x 5/8" O.D. (rubber) (25 ft. lg.)	--	93*-ALL	--	--
35	63505-84	INSULATOR, 1/2" I.D. (nylon) (8 ft. lg.)	--	93*-ALL	--	--

FLT MODELS

FLHTC DJ
 FLTC-U DM
 FLHTC-U DP
 FLHS FA
 FLHR FD

FXR MODELS

FXR EA
 FXRS-SP EG
 FXLR EL
 FXRS-CON EM

SOFTAIL MODELS

FLSTC BJ
 FXSTC BK
 FXSTS BL
 FLSTF BM
 FLSTN BN

DYNA MODELS

FXDL GD
 FXDWG GE
 FXDS-CON GG

FUEL TANK — SOFTAIL

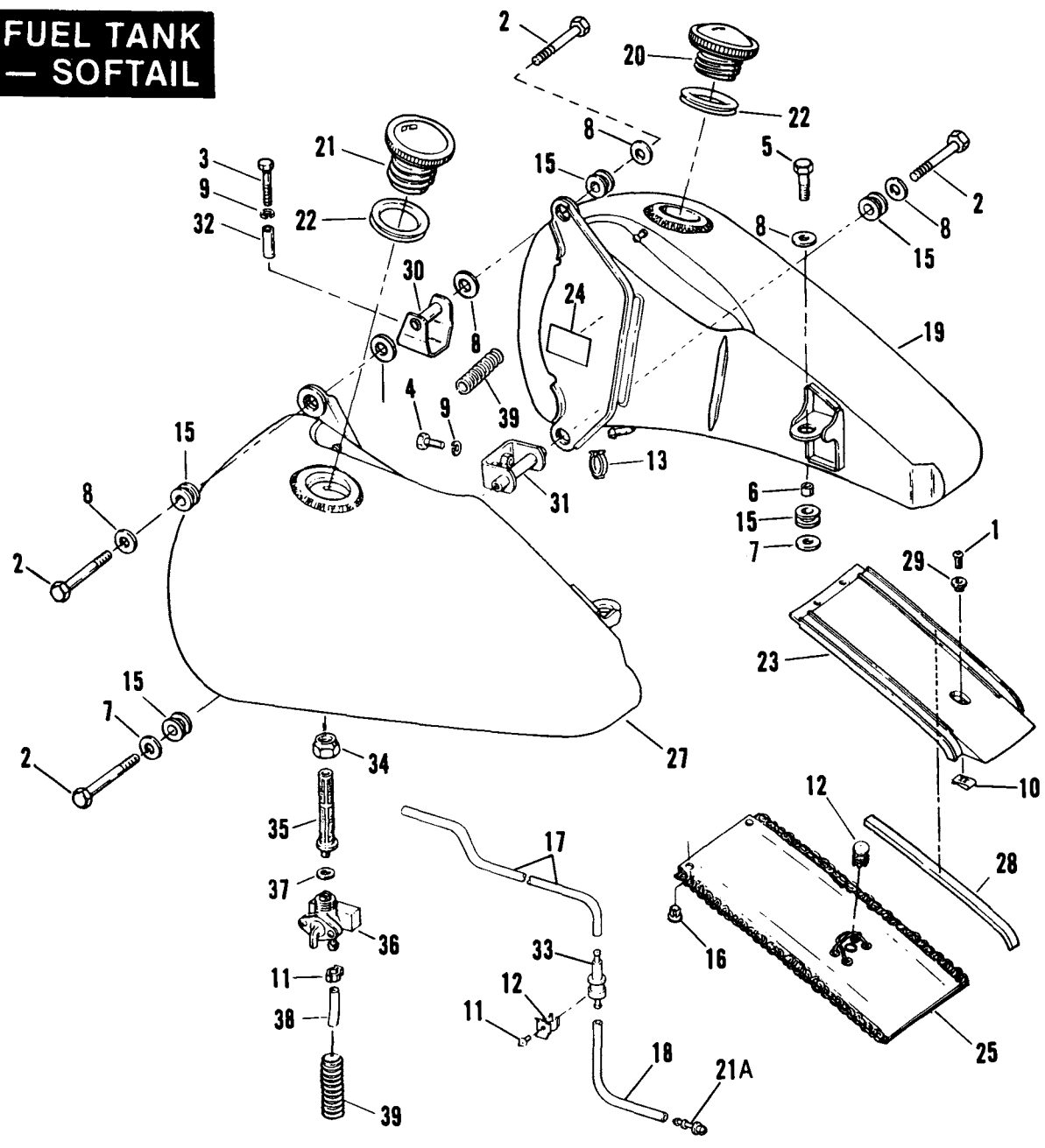

FUEL TANK - SOFTAIL MODELS

FB40B

INDEX NO.	PART NO.	DESCRIPTION	FLT MODELS	FXR MODELS	SOFTAIL MODELS	DYNA MODELS
NOTE: REFER TO DEALER ACCESORY GUIDE FOR PAINTED PART NUMBERS.						
1	924	SCREW	--	--	93*-BJ/K/L	--
2	3445	BOLT (4)	--	--	93*-ALL	--
3	3419	SCREW	--	--	93*-ALL	--
4	3987	BOLT (2)	--	--	93*-ALL	--
5	4014W	BOLT (2)	--	--	93*-ALL	--
6	5775	SPACER (2)	--	--	93*-ALL	--
7	6365	WASHER (4)	--	--	93*-ALL	--
8	6645	WASHER (6)	--	--	93*-ALL	--
9	7041	LOCKWASHER (2)	--	--	93*-ALL	--
10	8108	SPEED NUT	--	--	93*-BJ/K/L	--
11	8476	RIVET	--	--	93*-ALL	--
12	9890	CLIP, vapor valve	--	--	93*-ALL	--
13	10014	CLAMP, fuel hose (3)	--	--	93*-ALL	--
14	10040	CLIP	--	--	93*-BM	--
15	11447	GROMMET, fuel tank mounting (6)	--	--	93*-ALL	--
16	11717	FASTENING GROMMET (2)	--	--	93*-BM	--
17	27093-92A	HOSE, tank to vapor valve	--	--	93*-ALL	--
18	27102-92	HOSE, valve to air	--	--	93*-ALL	--
19	61052-92	FUEL TANK, right-3.5 gal. (prime)	--	--	93*-BJ/L/M	--
	61053-92	FUEL TANK, right-5 gal. (prime)	--	--	93*-BK/N	--
20	61272-92A	CAP, fuel filler - right	--	--	93*-ALL	--
21	61103-83B	CAP, fuel filler - left	--	--	93*-ALL	--
21A	61131-92	CONNECTION, ventline	--	--	93*-ALL	--
22	61109-85C	GASKET (2)	--	--	93*-ALL	--
23	61155-84	TRIM, fuel tank	--	--	93*-BJ/K/L	--
24	61157-87	PAD, protective (2)	--	--	93*-ALL	--
25	61165-89	TRIM PANEL	--	--	93*-BM/N	--
27	61237-91A	FUEL TANK, left - 3.5 gal. (prime)	--	--	93*-BJ/L/M	--
	61238-91A	FUEL TANK, left - 5 gal. (prime)	--	--	93*-BK/N	--
28	61640-84	FOAM STRIP (2)	--	--	93*-ALL	--
29	61641-84	SPACER, trim	--	--	93*-BJ/K/L	--
30	61660-85	BRACKET, fuel tank mounting - upper	--	--	93*-ALL	--
	61661-84	BRACKET, fuel tank mounting - upper	--	--	93*-ALL	--
31	61667-90A	BRACKET, fuel tank mounting - lower	--	--	93*-ALL	--
32	62043-81A	SPACER	--	--	93*-ALL	--
33	62150-85	VAPOR VALVE	--	--	93*-ALL	--
34	62161-75	NUT, fuel valve	--	--	93*-ALL	--
35	62166-81A	FILTER, fuel valve	--	--	93*-ALL	--
36	62167-81	FUEL VALVE, only	--	--	93*-ALL	--
37	62172-75	GASKET, fuel valve	--	--	93*-ALL	--

NOTE: Hose or insulator is sold in bulk length under the following part numbers. Cut to length.

38	63501-68	HOSE, 1/4" I.D. x 5/8" O.D. (rubber) (25 ft. lg.)	--	--	93*-ALL	--
39	63505-84	INSULATOR, 1/2" I.D. (nylon) (8 ft. lg.)	--	--	93*-ALL	--

FLT MODELS

FLHTC
FLTC-U
FLHTC-U
FLHS
FLHR

DJ
DM
DP
FA
FD

FXR MODELS

FXR
FXRS-SP
FXLR
FXRS-CON
EA
EG
EL
EM

SOFTAIL MODELS

FLSTC
FXSTC
FXSTS
FLSTF
FLSTN
BJ
BK
BL
BM
BN

DYNA MODELS

FXDL
FXDWG
FXDS-CON
GD
GE
GG

FUEL TANKS - DYNA

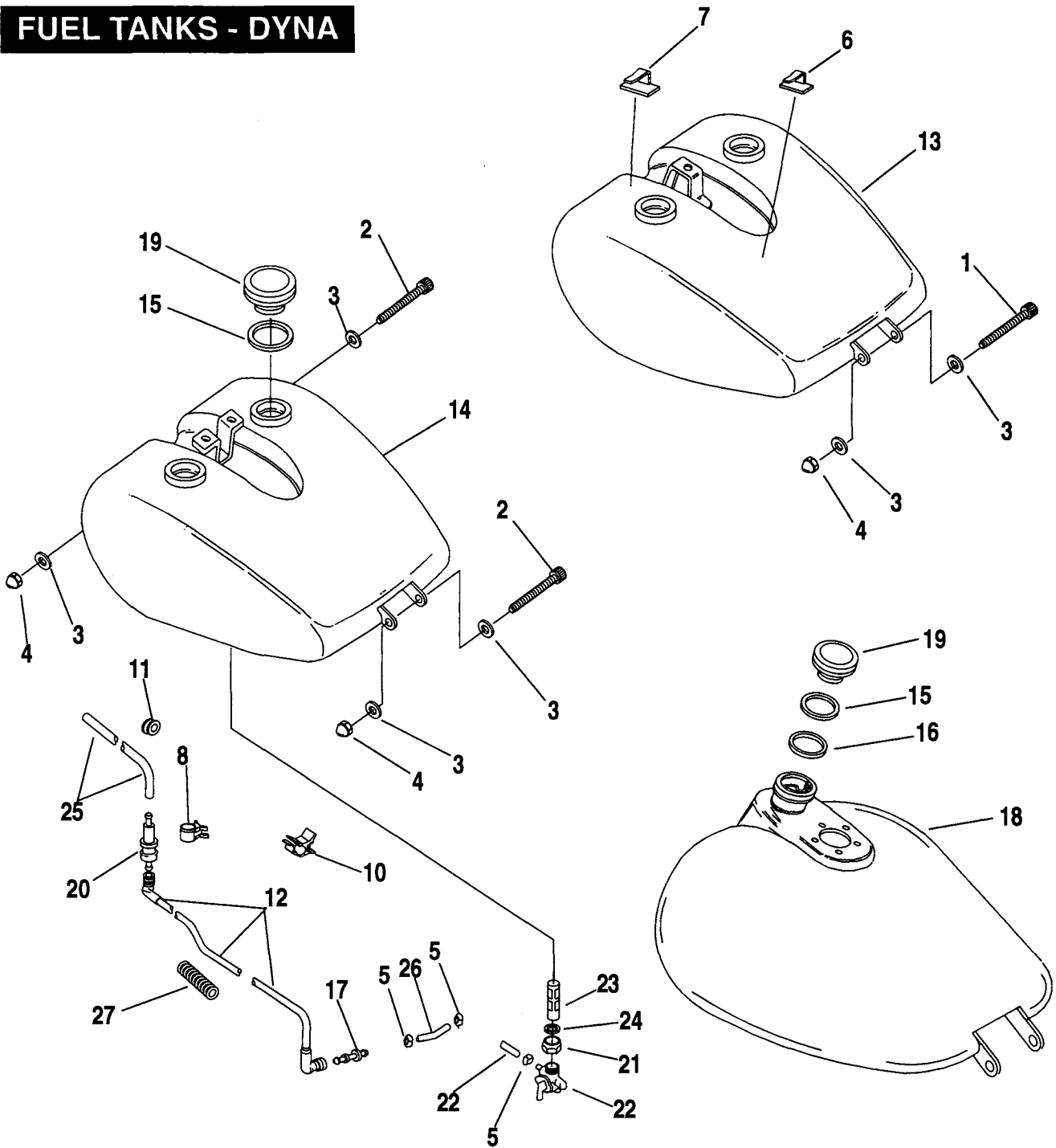

INDEX NO.	PART NO.	DESCRIPTION	FLT MODELS	FXR MODELS	SOFTAIL MODELS	DYNA MODELS
NOTE: REFER TO DEALER ACCESSORY GUIDE FOR PAINTED PART NUMBERS.						
1	3427	BOLT (2)	--	--	--	93*-GE
2	3530	BOLT (2 - GD)	--	--	--	93*-ALL
3	6109	WASHER (4)	--	--	--	93*-ALL
4	7507	ACORN NUT (chrome) (2)	--	--	--	93*-ALL
5	10014	CLAMP, (4)	--	--	--	93*-ALL
6	10102	CLIP (2)	--	--	--	93*-ALL
7	10103	CLIP (2)	--	--	--	93*-GE
8	10108	CLIP, vapor valve	--	--	--	93*-ALL
10	10130	CLIP, backbone	--	--	--	94*-ALL
11	11460	GROMMET, fuel hose	--	--	--	93*-ALL
12	27296-92	HOSE	--	--	--	93*-ALL
13	61039-93	FUEL TANK KIT (prime)	--	--	--	93*-GE
14	61054-92	FUEL TANK (prime)	--	--	--	93*-GD
15	61109-85C	GASKET, filler cap	--	--	--	93*-ALL
16	61112-82A	BOOT, filler tube	--	--	--	94*-GG
17	61131-92	CONNECTOR, vent line	--	--	--	93*-ALL
18	61267-94	FUEL TANK (prime)	--	--	--	94*-GG
19	61272-92A	FILLER CAP, vac. vent	--	--	--	93*-ALL
20	62150-85	VAPOR VALVE	--	--	--	93*-ALL
21	62161-75	NUT	--	--	--	93*-ALL
22	62167-81	VALVE, body	--	--	--	93*-ALL
23	62170-81A	FILTER	--	--	--	93*-ALL
24	62172-75	GASKET, fuel filter	--	--	--	93*-ALL
 NOTE: Hose or insulator is sold in bulk length under the following part numbers. Cut to length.						
25	27138-90	HOSE 3/16" I.D. x 11/32" O.D. (rubber) (10 ft. lg.)--	--	--	--	93*-ALL
26	63501-68	HOSE, 1/4" I.D. x 5/8" O.D. (rubber) (25 ft. lg.)	--	--	--	93*-ALL
27	63505-84	INSULATOR, 1/2" I.D. (nylon) (8 ft. lg.)	--	--	--	93*-ALL
 H-D INTERNATIONAL ONLY						
10	10131	CLIP, backbone (HDI only)	--	--	--	94*-ALL
	14260-91	DECAL (Swiss only)	--	--	--	93*-ALL

FLT MODELS
 FLHTC
 FLTC-U
 FLHTC-U
 FLHS
 FLHR

FXR MODELS
 DJ
 DM
 DP
 FA
 FD
 FXR
 FXRS-SP
 FXLR
 FXRS-CON
 EA
 EG
 EL
 EM

SOFTAIL MODELS
 FLSTC
 FXSTC
 FXSTS
 FLSTF
 FLSTN
 BJ
 BK
 BL
 BM
 BN

DYNA MODELS
 FXDL
 FXDWG
 FXDS-CON
 GD
 GE
 GG

FUEL TANK - FLHR

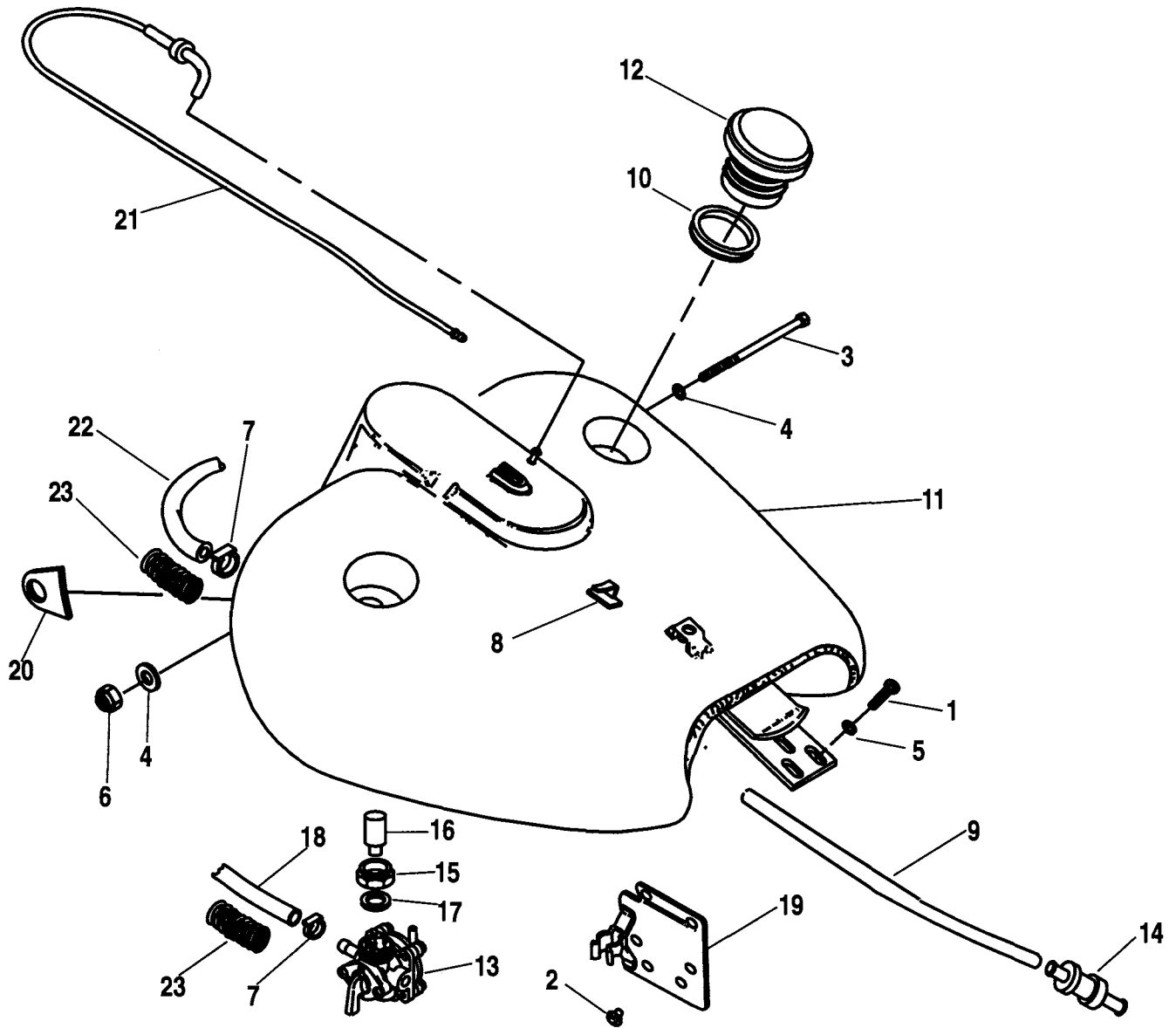

INDEX NO.	PART NO.	DESCRIPTION	FLT MODELS	FXR MODELS	SOFTAIL MODELS	DYNA MODELS
1	939	SCREW (2)	94*-FD	--	--	--
2	3739	SCREW (2)	94*-FD	--	--	--
3	4061	SCREW	94*-FD	--	--	--
4	6702	WASHER (2)	94*-FD	--	--	--
5	6703	WASHER (2)	94*-FD	--	--	--
6	7531	ACORN NUT	94*-FD	--	--	--
7	10014	CLAMP (4)	94*-FD	--	--	--
8	10102	CLIP, adhesive back (2)	94*-FD	--	--	--
	10103	CLIP, adhesive back (2)	94*-FD	--	--	--
9	27191-94	TUBE, tank to valve	94*-FD	--	--	--
	27291-93	TUBE, valve to atmosphere	94*-FD	--	--	--
10	61109-85C	GASKET, filler cap	94*-FD	--	--	--
11	61225-94	FUEL TANK (prime)	94*-FD	--	--	--
12	61272-92A	FILLER CAP, vac. vent	94*-FD	--	--	--
13	61338-84	FUEL VALVE BODY	94*-FD	--	--	--
14	62150-85	VAPOR VALVE	94*-FD	--	--	--
15	62161-75	NUT, fuel valve	94*-FD	--	--	--
16	62170-81A	FILTER, fuel valve	94*-FD	--	--	--
17	62172-75	GASKET, fuel valve	94*-FD	--	--	--
18	62356-92	HOSE, fuel	94*-FD	--	--	--
19	70995-93	BRACKET, valve mtg.	94*-FD	--	--	--
20	70999-94	TRIM, fuel tank	94*-FD	--	--	--
NOTE: Hose or insulator is sold in bulk length under the following part numbers. Cut to length.						
21	27138-90	HOSE 3/16" I.D. x 11/32" O.D. (rubber) (10' lg.)	94*-FD	--	--	--
22	63501-68	HOSE, 1/4" I.D. x 5/8" O.D. (rubber) (25' lg.)	94*-FD	--	--	--
23	63505-84	INSULATOR, 1/2" I.D. (nylon) (8' lg.)	94*-FD	--	--	--

FLT MODELS

FLHTC DJ
 FLTC-U DM
 FLHTC-U DP
 FLHS FA
 FLHR FD

FXR MODELS

FXR EA
 FXRS-SP EG
 FXLR EL
 FXRS-CON EM

SOFTAIL MODELS

FLSTC BJ
 FXSTC BK
 FXSTS BL
 FLSTF BM
 FLSTN BN

DYNA MODELS

FXDL GD
 FXDWG GE
 FXDS-CON GG

FUEL TANK TRIM

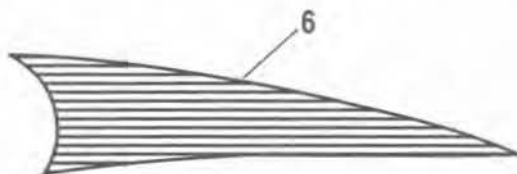
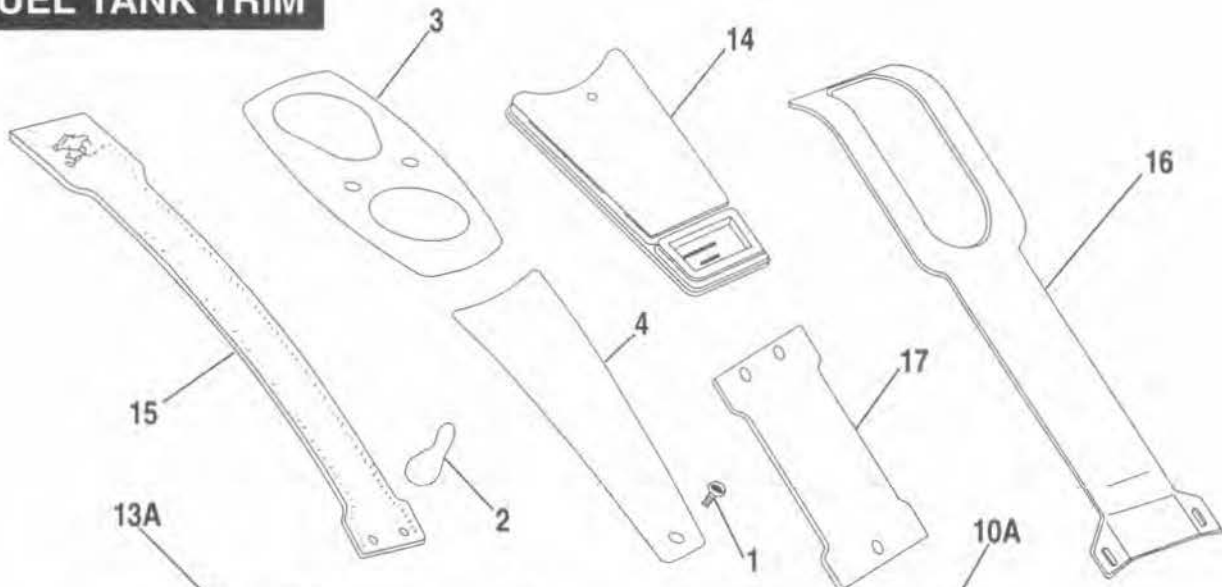

INDEX NO.	PART NO.	DESCRIPTION	FLT MODELS	FXR MODELS	SOFTAIL MODELS	DYNA MODELS
1	3652	SCREW	--	93*-ALL	--	--
2	11174	O-RING	--	93*-EL	--	93*-GE
3	14055-84	TRIM, upper console (black)	--	93*-EG/M	--	--
4	14056-84	TRIM, lower console (black)	--	93*-EG/M	--	--
5	14214-90	DECAL (black, gold & red) (2)	93*-DM/P	--	--	--
	14240-90	DECAL (silver & blue) (2)	93*-DM/P	--	--	--
6	14286-94	DECAL (burgundy & gold) (2)	94*-DM/P	--	--	--
	14395-93	DECAL (aqua, meteor & blue)	93*-DM/P	--	--	--
	14215-89	DECAL, left (silver)	93*-DM/P	--	--	--
	14216-89	DECAL, right (silver)	93*-DM/P	--	--	--
	14242-90	DECAL, left (red)	93*-DM/P	--	--	--
	14244-90	DECAL, right (red)	93*-DM/P	--	--	--
	14284-94	DECAL, right (gold)	94*-DM/P	--	--	--
	14285-94	DECAL, left (gold)	94*-DM/P	--	--	--
7	14228-91	DECAL (silver, gray & orange) (2)	--	--	93*-BM	--
	14287-94	DECAL (blue, aqua & silver) (2)	--	--	94*-BM	--
	14388-93	DECAL (blue, meteor & silver) (2)	--	--	93*-BM	--
	14390-93	DECAL (red, meteor, gold, silver & orange)(2)	--	--	93*-BM	--
	61366-92	TRIM, right (black)	--	--	93-BN	--
	61366-94	TRIM, right (white)	--	--	94*-BN	--
8	61367-92	TRIM, left (black)	--	--	93-BN	--
	61367-94	TRIM, left (white)	--	--	94*-BN	--
	14261-91	DECAL (silver, red, orange & black)(2)	--	--	--	92*-GD/G
	14262-91	DECAL (silver, meteor, grey & black)(2)	--	--	--	93*-GD/G
8A	14396-93	DECAL (silver, meteor, grey & black)(2)	--	--	--	93*-GD/G
	14289-94	DECAL (gold & black) (2)	--	94*-EA/L	--	--
9	14293-94	DECAL (blue & black) (2)	--	94*-EA/L	--	--
	14278-93	TRIM, right, 90th anniversary	93-DJ/M/P	93-EL	--	93-GE
9A	14279-93	TRIM, left, 90th anniversary	93-DJ/M/P	93-EL	--	93-GE
	14295-94	DECAL, left (red & pale gold)	94*-DJ	--	--	--
10	14296-94	DECAL, right (red & pale gold)	94*-DJ	--	--	--
	14297-94	DECAL, left (sky blue & silver)	94*-DJ	--	--	--
	14298-94	DECAL, right (sky blue & silver)	94*-DJ	--	--	--
	14411-94	DECAL, left (red & birch white)	94*-DJ	--	--	--
	14412-94	DECAL, left (red & birch white)	94*-DJ	--	--	--
	14308-93	DECAL, right (red, black, yellow, white & gold)	--	--	--	93*-GE
10	14309-93	DECAL, left (red, black, yellow, white & gold)	--	--	--	93*-GE
	14310-93	DECAL, left (meteor, aqua, blue & silver)	--	--	--	93*-GE
	14313-93	DECAL, right (meteor, aqua, blue & silver)	--	--	--	93*-GE
	14402-93	DECAL, right (gold, black, yellow, white & red)	--	--	--	93*-GE
	14402-93	DECAL, right (gold, black, yellow, white & red)	--	--	--	93*-GE

FLT MODELS

FLHTC DJ
 FLTC-U DM
 FLHTC-U DP
 FLHS FA
 FLHR FD

FXR MODELS

FXR EA
 FXRS-SP EG
 FXLR EL
 FXRS-CON EM

SOFTAIL MODELS

FLSTC BJ
 FXSTC BK
 FXSTS BL
 FLSTF BM
 FLSTN BN

DYNA MODELS

FXDL GD
 FXDWG GE
 FXDS-CON GG

FUEL TANK TRIM

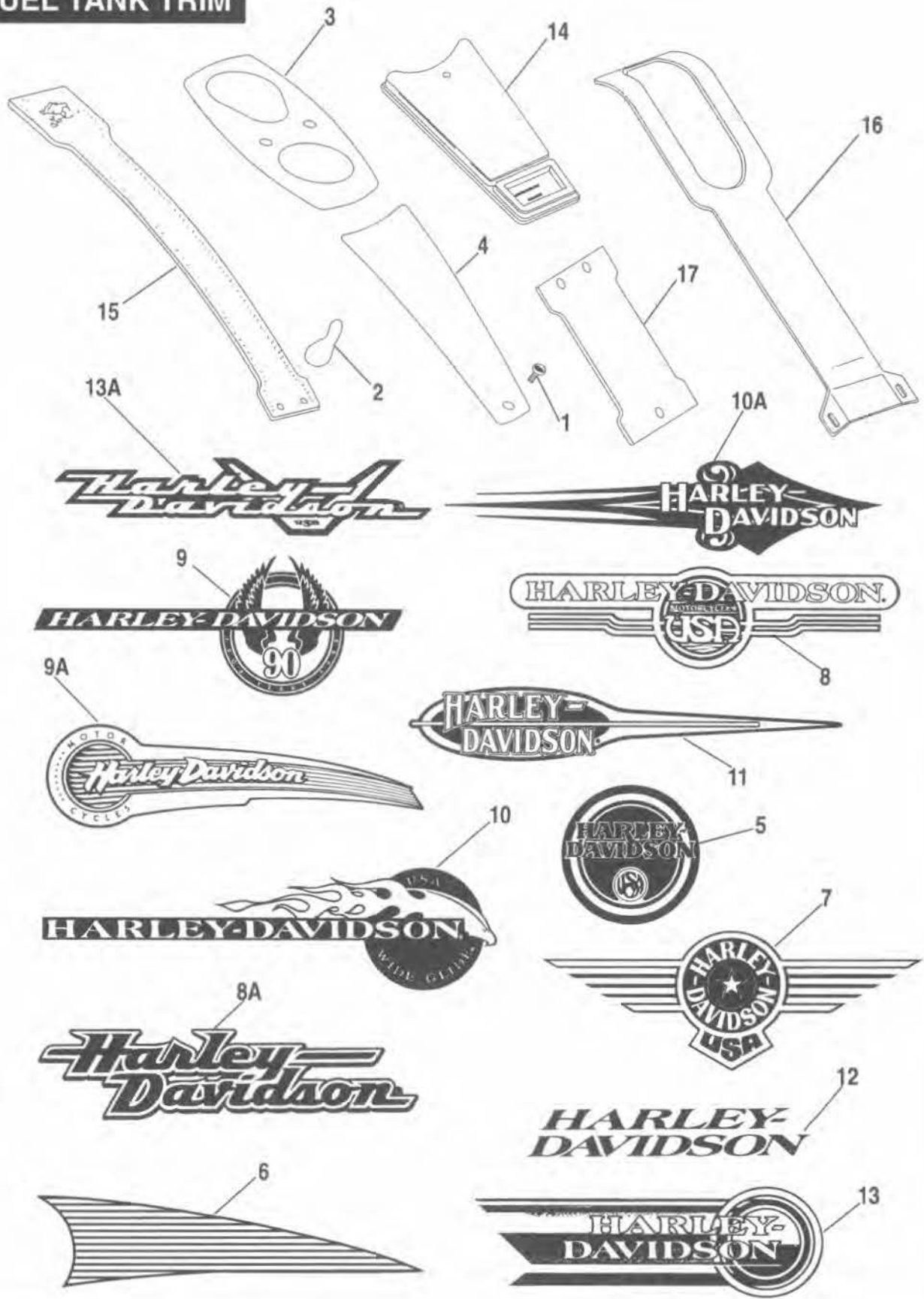

FUEL TANK TRIM (CONT'D)

FB40E-2

INDEX NO.	PART NO.	DESCRIPTION	FLT MODELS	FXR MODELS	SOFTAIL MODELS	DYNA MODELS
10A	14335-90	DECAL, left (gold, red & orange)	--	--	93*-BJ	--
	14338-93	DECAL, right (pale gold, dk. wineberry & red)	--	--	93*-BJ	--
	14339-90	DECAL, right (gold, red & orange)	--	--	93*-BJ	--
	14341-93	DECAL, left (pale gold, dk. wineberry & red)	--	--	93*-BJ	--
	14386-93	DECAL, left (sky blue, dk. aqua blue & red)	--	--	93*-BJ	--
	14387-93	DECAL, right (sky blue, dk. aqua blue & red)	--	--	93*-BJ	--
11	14348-92	DECAL, left (gold, black, & creme)	--	93-ALL	--	--
	14349-92	DECAL right (gold, black, & creme)	--	93-ALL	--	--
	14351-92	DECAL, left (silver, blue & creme)	--	93-ALL	--	--
	14352-92	DECAL, right (silver, blue, & creme)	--	93-ALL	--	--
	14380-93	DECAL, right (red, silver, black & creme)	--	93-EG/L/M	--	--
	14381-93	DECAL left (blue, silver, black & creme)	--	93-EG/L/M	--	--
	14382-93	DECAL, left (silver, blue, black & creme)	--	93-ALL	--	--
	14383-93	DECAL, right (silver, blue, black & creme)	--	93-ALL	--	--
12	14353-92	DECAL, left (black & red)	--	--	93*-BK/L	--
	14354-92	DECAL, right (black & red)	--	--	93*-BK/L	--
	14355-92	DECAL, left (black & orange)	--	--	93*-BK/L	--
	14356-92	DECAL, right (black & orange)	--	--	93*-BK/L	--
	14359-92	DECAL, left (dark candy sapphire & silver)	--	--	93*-BK/L	--
	14360-92	DECAL, right (dark candy sapphire & silver)	--	--	93*-BK/L	--
	14384-93	DECAL, left (aqua blue & meteor)	--	--	93*-BK/L	--
	14385-93	DECAL, right (aqua blue & meteor)	--	--	93*-BK/L	--
	14397-93	DECAL, right (pale gold & olive drab)	--	--	93*-BK/L	--
	14398-93	DECAL, right (pale gold & olive drab)	--	--	93*-BK/L	--
	13	14365-92	DECAL, left (burgundy, orange, & gold)	93-FA,DJ	--	--
14366-92		DECAL, right (burgundy, orange, & gold)	93-FA,DJ	--	--	--
14369-92		DECAL, left (dark blue, red, gray)	93-FA,DJ	--	--	--
14370-92		DECAL, right (dark blue, red, gray)	93-FA,DJ	--	--	--
14371-92		DECAL, left (brown, red, & orange)	93-FA	--	--	--
14372-92		DECAL, right (brown, red, & orange)	93-FA	--	--	--
14391-93		DECAL, left (silver, aqua, grey, blue & black)	93*-DM/P	--	--	--
14392-93		DECAL, right (silver, aqua, grey, blue & black)	93*-DM/P	--	--	--
13A	14416-94	DECAL, left (dark red, black & red)	94*-FD	--	--	--
	14417-94	DECAL, right (dark red, black & red)	94*-FD	--	--	--
	14418-94	DECAL, left (dark blue, silver & light blue)	94*-FD	--	--	--
	14419-94	DECAL, right (dark blue, silver & light blue)	94*-FD	--	--	--
14	60957-89	INSERT, console panel (black)	93-FA	--	--	--
	60973-90	INSERT, console panel (black)	93*-DJ	--	--	--
	60983-93	INSERT, console panel, 90th anniversary	93*-DJ	--	--	--
15	61134-88	STRAP, laced (leather)	--	93*-EL	--	--
16	61651-90	TRIM PANEL	--	--	--	93*-GD
17	61166-93	TRIM PANEL	--	--	--	93*-GE

FLT MODELS

FLHTC DJ
 FLTC-U DM
 FLHTC-U DP
 FLHS FA
 FLHR FD

FXR MODELS

FXR EA
 FXRS-SP EG
 FXLR EL
 FXRS-CON EM

SOFTAIL MODELS

FLSTC BJ
 FXSTC BK
 FXSTS BL
 FLSTF BM
 FLSTN BN

DYNA MODELS

FXDL GD
 FXDWG GE
 FXDS-CON GG

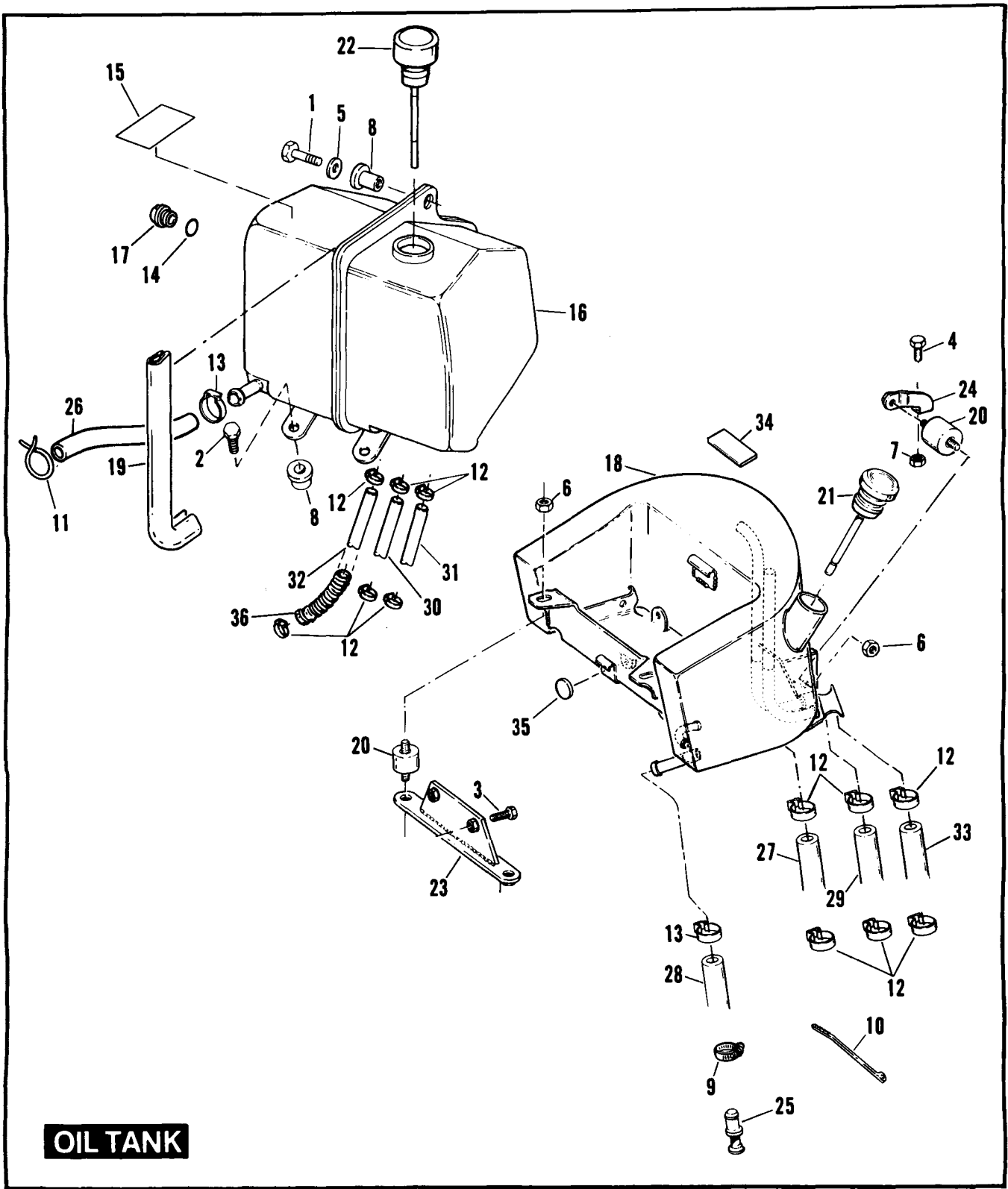

OIL TANK

INDEX NO.	PART NO.	DESCRIPTION	FLT MODELS	FXR MODELS	SOFTAIL MODELS	DYNA MODELS
1	2551W	BOLT (2)	--	93*-ALL	--	--
2	2607	SCREW (2)	--	93*-ALL	--	--
3	3546	BOLT (2)	--	--	93*-ALL	--
4	3987	BOLT	--	--	93*-ALL	--
5	6703	WASHER	--	93*-ALL	--	--
6	7686	LOCKNUT (5)	--	--	93*-ALL	--
7	7531	NUT	--	--	93*-ALL	--
8	8099	WELL NUT (3)	--	93*-ALL	--	--
9	9969	CLAMP, drain hose	--	--	93*-ALL	--
10	10006	CABLE STRAP, oil hoses (as required)	--	--	93*-ALL	--
11	10049	CLAMP, drain hose	--	93*-ALL	--	--
12	10080	CLAMP (6)	--	93*-ALL	93*-ALL	--
13	10086	CLAMP, drain hose (3 - Softail)	--	93*-ALL	93*-ALL	--
14	11132	O-RING	--	93*-ALL	--	--
15	14101-84	LABEL, instruction	--	93*-ALL	--	--
16	62414-91	OIL TANK (black)	--	93*-ALL	--	--
17	62460-86	SIGHT GLASS, oil level	--	93*-ALL	--	--
18	62498-91	OIL TANK (chrome)	--	--	93*-ALL	--
19	62540-83	TRIM STRIP	--	93*-ALL	--	--
20	62563-65	RUBBER MOUNT (4)	--	--	93*-ALL	--
21	62634-84	FILLER CAP, w/ dipstick	--	--	93*-ALL	--
22	62637-84	FILLER CAP, w/ dipstick	--	93*-ALL	--	--
23	62704-93	BRACKET, rear	--	--	93*-ALL	--
24	62707-84	BRACKET, front - tank to frame	--	--	93*-ALL	--
25	62725-90	PLUG, oil drain	--	--	93*-ALL	--
26	63513-88R	HOSE, tank drain	--	93*-ALL	--	--
27	63515-92	HOSE, tank to pump	--	--	93*-ALL	--
28	63553-91	HOSE, tank drain	--	--	93*-ALL	--
29	63556-87	HOSE, filter to tank	--	--	93*-ALL	--
30	63557-92	HOSE, tank to pump	--	93*-ALL	--	--
31	63559-91	HOSE, crankcase to tank vent	--	93*-ALL	--	--
32	63562-92	HOSE, filter to tank vent	--	93*-ALL	--	--
33	63572-86	HOSE, tank vent	--	--	93*-ALL	--
34	66042-79A	WARNING LABEL	--	93*ALL	93*-ALL	--
35	75101-82	SPACER (rubber)	--	--	93-ALL	--
NOTE: Insulator is sold in bulk length under the following part number. Cut to length.						
36	63497-89	INSULATOR, 5/8 I.D. (nylon) (8 ft. lg.)	--	93*-ALL	93*-ALL	--

FLT MODELS

FLHTC DJ
 FLTC-U DM
 FLHTC-U DP
 FLHS FA
 FLHR FD

FXR MODELS

FXR EA
 FXRS-SP EG
 FXLR EL
 FXRS-CON EM

SOFTAIL MODELS

FLSTC BJ
 FXSTC BK
 FXSTS BL
 FLSTF BM
 FLSTN BN

DYNA MODELS

FXDL GD
 FXDWG GE
 FXDS-CON GG

OIL FILTERS & MOUNTS

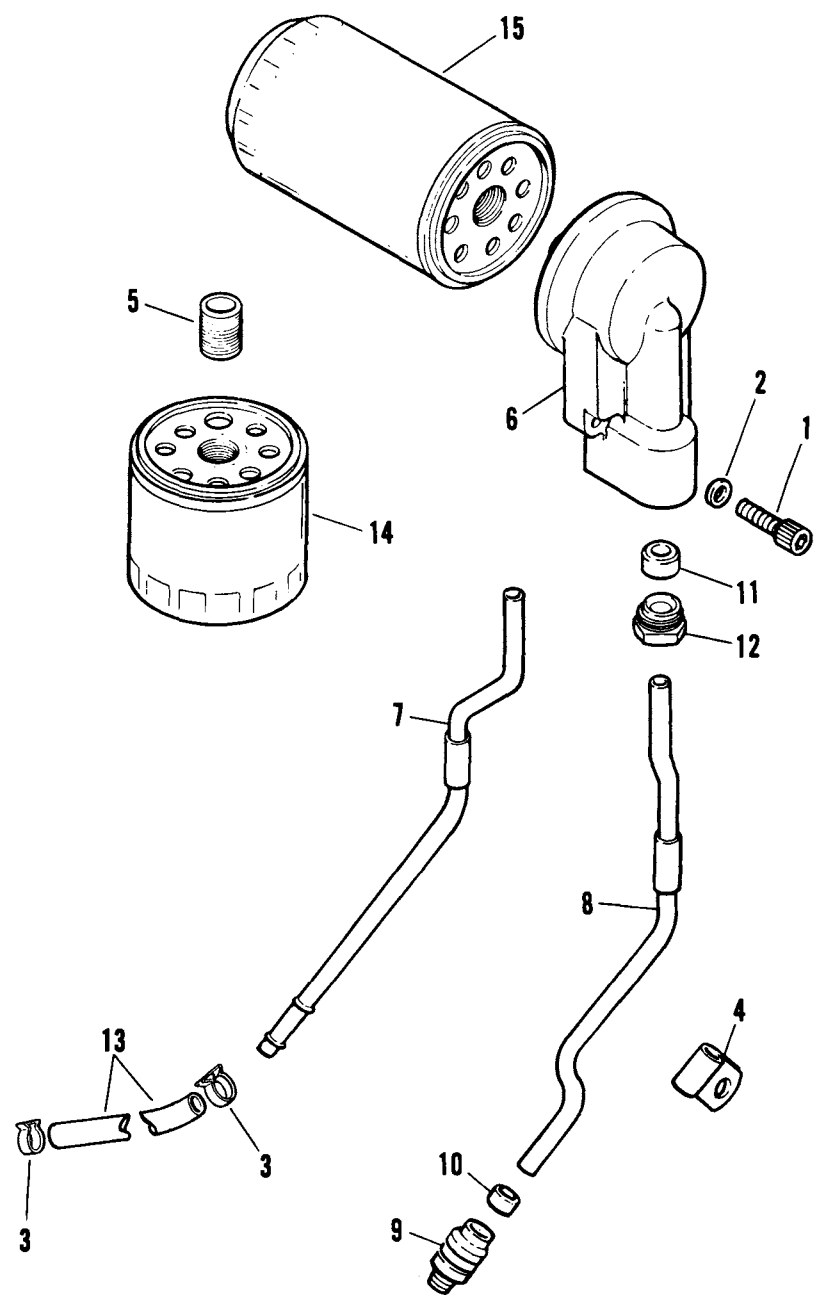

INDEX NO.	PART NO.	DESCRIPTION	FLT MODELS	FXR MODELS	SOFTAIL MODELS	DYNA MODELS
1	3210A	SCREW, socket head, (2)	93*-ALL	93*-ALL	93*-ALL	93*-ALL
2	6771A	WASHER (2)	93*-ALL	93*-ALL	93*-ALL	93*-ALL
3	10080	CLAMP (4)	93*-ALL	93*-ALL	93*-ALL	93*-ALL
4	10112	CLAMP	93*-ALL	93*-ALL	93*-ALL	93*-ALL
5	26352-85	ADAPTOR, oil filter	93*-ALL	93*-ALL	93*-ALL	93*-ALL
6	26378-92	OIL FILTER MOUNT (black)	93*-DJ/M/P	93*-EG/M	93*-ALL	93*-ALL
	26381-92	OIL FILTER MOUNT (silver)	93*-FA	93*-EA	--	--
7	33518-92	TUBE, return	93*-ALL	93*-ALL	--	93*-ALL
	33519-92A	TUBE, return	--	--	93*-ALL	--
8	33520-92	TUBE, feed	93*-ALL	93*-ALL	93*-ALL	93*-ALL
9	63523-92	FITTING, straight w/#10	93*-ALL	93*-ALL	93*-ALL	93*-ALL
10	63525-92	SEAL	93*-ALL	93*-ALL	93*-ALL	93*-ALL
11	63528-92	SEAL & FERRULE (2)	93*-ALL	93*-ALL	93*-ALL	93*-ALL
12	63530-92	FITTING, male nut (2)	93*-ALL	93*-ALL	93*-ALL	93*-ALL
13	63556-92	HOSE, filter line to tank	--	--	93*-ALL	--
	63538-92	HOSE, filter line to tank	--	--	--	93*-ALL
	63562-92	HOSE, filter line to tank	--	93*-ALL	--	--
14	63796-77A	OIL FILTER (chrome)	93*-ALL	93*-ALL	93*-ALL	--
15	63813-90	OIL FILTER (chrome)	--	--	--	93*-ALL

FLT MODELS

FLHTC DJ
 FLTC-U DM
 FLHTC-U DP
 FLHS FA
 FLHR FD

FXR MODELS

FXR EA
 FXRS-SP EG
 FXLR EL
 FXRS-CON EM

SOFTAIL MODELS

FLSTC BJ
 FXSTC BK
 FXSTS BL
 FLSTF BM
 FLSTN BN

DYNA MODELS

FXDL GD
 FXDWG GE
 FXDS-CON GG

EXHAUST SYSTEM — FLT

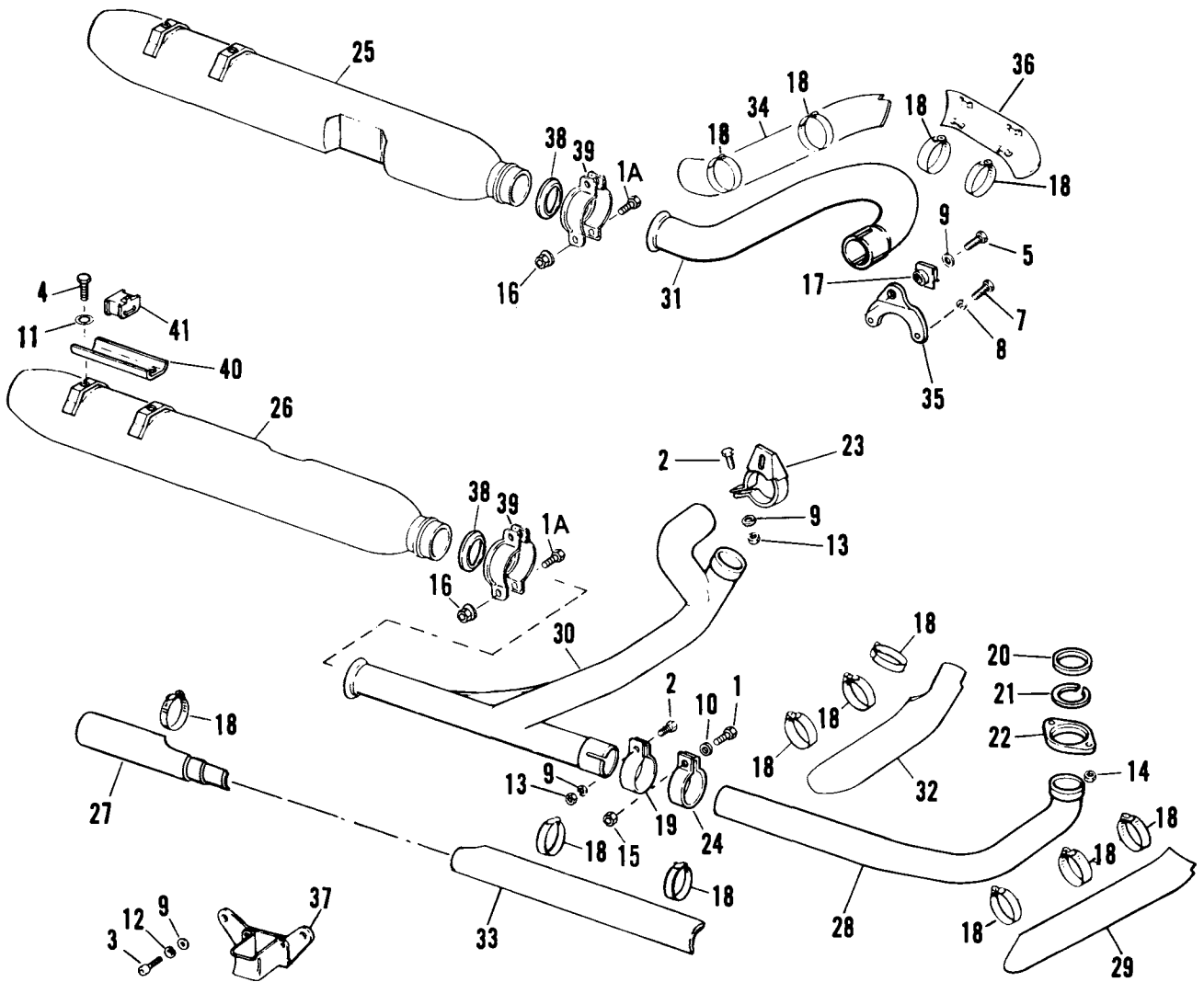

INDEX NO.	PART NO.	DESCRIPTION	FLT MODELS	FXR MODELS	SOFTAIL MODELS	DYNA MODELS
1	2551W	BOLT	93*-ALL	--	--	--
1A	2557	SCREW (4)	93*-ALL	--	--	--
2	2818	BOLT (2)	93*-ALL	--	--	--
3	3210A	SCREW (4)	93*-ALL	--	--	--
4	3953W	BOLT (4)	93*-ALL	--	--	--
5	3987	BOLT	93*-ALL	--	--	--
7	4326A	SCREW (2)	93*-ALL	--	--	--
8	6099	WASHER (4)	93*-ALL	--	--	--
9	6702	WASHER (3)	93*-ALL	--	--	--
10	6703	WASHER	93*-ALL	--	--	--
11	7041	LOCKWASHER (4)	93*-ALL	--	--	--
12	7127	LOCKWASHER (4)	93*-ALL	--	--	--
13	7531	LOCKNUT (2)	93*-ALL	--	--	--
14	7593	NUT (4)	93*-ALL	--	--	--
15	7742	LOCKNUT	93*-ALL	--	--	--
16	7860	LOCKNUT (4)	93*-ALL	--	--	--
17	8101	CLIP NUT	93*-ALL	--	--	--
18	9955	CLAMP, shield (12)	93*-ALL	--	--	--
19	65276-62	MUFFLER CLAMP	93*-ALL	--	--	--
20	65324-83A	GASKET, exhaust port (2)	93*-ALL	--	--	--
21	65325-83	RETAINING RING, exhaust gasket (2)	93*-ALL	--	--	--
22	65328-83	CLAMP, exhaust manifold	93*-ALL	--	--	--
23	65502-89	CLAMP, left exhaust pipe	93*-ALL	--	--	--
24	65519-52B	CLAMP, pipe to bracket	93*-ALL	--	--	--
25	65538-85	MUFFLER, left	93*-ALL	--	--	--
26	65539-86	MUFFLER, right	93*-ALL	--	--	--
27	65611-92	SHIELD, right exhaust pipe-rear	93*-ALL	--	--	--
28	65621-83	EXHAUST PIPE, right	93*-ALL	--	--	--
29	65630-83A	SHIELD, front exhaust pipe	93*-ALL	--	--	--
30	65626-85A	EXHAUST PIPE, right - rear	93*-ALL	--	--	--
31	65627-85	EXHAUST PIPE, left	93*-ALL	--	--	--
32	65632-83B	SHIELD, rear exhaust pipe	93*-ALL	--	--	--
33	65634-92	SHIELD, right exhaust pipe-front	93*-ALL	--	--	--
34	65636-85	SHIELD, left exhaust pipe	93*-ALL	--	--	--
35	65645-89	BRACKET, left - rear exhaust pipe	93*-ALL	--	--	--
36	65647-83	SHIELD, left exhaust pipe	93*-ALL	--	--	--
37	65678-85B	BRACKET, rear exhaust pipe	93*-ALL	--	--	--
38	65721-85	GASKET, muffler clamp (2)	93*-ALL	--	--	--
39	65722-85B	MUFFLER CLAMP KIT w/ #1 & 16 (4)	93*-ALL	--	--	--
40	65723-85	MOUNTING BRACKET (2)	93*-ALL	--	--	--
41	65724-85	MOUNT (rubber) (2)	93*-ALL	--	--	--

H-D INTERNATIONAL ONLY

26	65682-89B	MUFFLER, left (HDI only)	93*-ALL	--	--	--
	65862-91	MUFFLER, left (catalytic) (Swiss only)	93*-ALL	--	--	--
27	65680-89B	MUFFLER, right (HDI only)	93*-ALL	--	--	--
	65863-91	MUFFLER, right (catalytic) (Swiss only)	93*-ALL	--	--	--

FLT MODELS

FLHTC
FLTC-U
FLHTC-U
FLHS
FLHR

DJ
DM
DP
FA
FD

FXR MODELS

FXR
FXRS-SP
FXLR
FXRS-CON

EA
EG
EL
EM

SOFTAIL MODELS

FLSTC
FXSTC
FXSTS
FLSTF
FLSTN

BJ
BK
BL
BM
BN

DYNA MODELS

FXDL
FXDWG
FXDS-CON

GD
GE
GG

EXHAUST SYSTEM - FXR & SOFTAIL

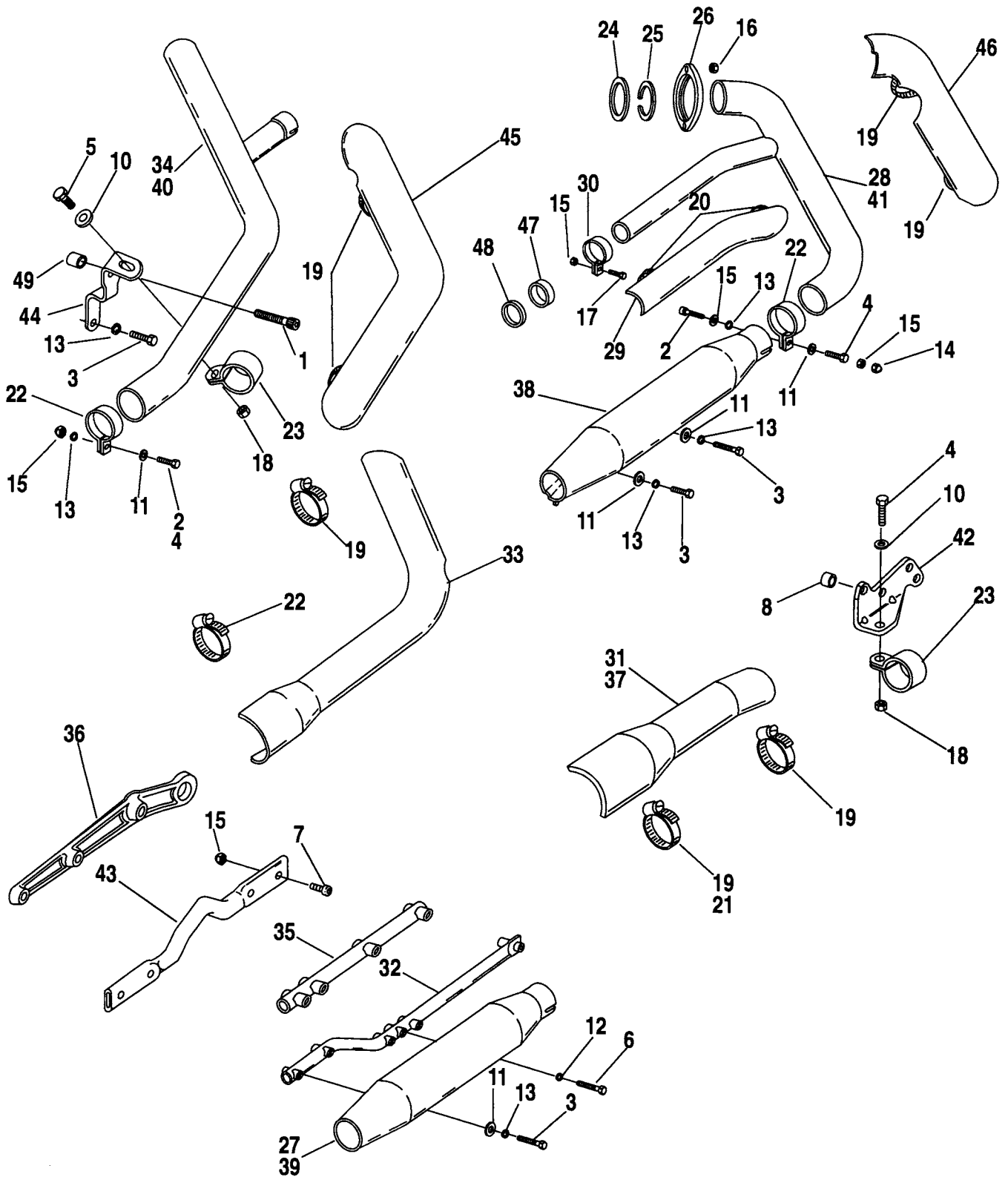

INDEX NO.	PART NO.	DESCRIPTION	FLT MODELS	FXR MODELS	SOFTAIL MODELS	DYNA MODELS
1	3485A	SCREW	--	93*-ALL	--	--
2	2818	SCREW (2)	--	93*-ALL	93*-ALL	--
3	4017	BOLT (4 - Softail)	--	93*-ALL	93*-ALL	--
4	4036	BOLT	--	93*-ALL	--	--
5	4319	BOLT (2)	--	93*-ALL	--	--
6	4722	BOLT (2)	--	--	93*-ALL	--
7	5445W	BOLT (4 - FXR)	--	93*-ALL	93*-BJ/K/L	--
8	5887	SPACER	--	93*-ALL	--	--
10	6701	WASHER (2)	--	93*-ALL	--	--
11	6702	WASHER (2; 6 - Softail)	--	93*-ALL	93*-ALL	--
12	7038	LOCKWASHER (2)	--	--	93*-ALL	--
13	7041	LOCKWASHER (3 - FXR; 4 - Softail)	--	93*-ALL	93*-ALL	--
14	7507	ACORN NUT	--	--	93*-BK/L	--
15	7531	LOCKNUT (4; 2 - Softail)	--	93*-ALL	93*-ALL	--
16	7593	NUT (4)	--	93*-ALL	93*-ALL	--
17	7748W	BOLT	--	--	93*-BJ/K/L	--
18	7782	NUT (2)	--	93*-ALL	--	--
19	9955	CLAMP (6; 5 - BJ/M/N; 4 - BK/L)	--	93*-ALL	93*-ALL	--
20	10048	CLAMP (2)	--	93*-ALL	93*-BK/L	--
21	10074	CLAMP, shield (front - BJ; 2 - BM/N)	--	--	93*-BJ/M/N	--
22	65276-62	CLAMP, muffler (2)	--	93*-ALL	93*-ALL	--
23	65302-82	CLAMP, exhaust pipe (2)	--	93*-ALL	--	--
24	65324-83A	GASKET, exhaust port	--	93*-ALL	93*-ALL	--
25	65325-83	RETAINING RING, exhaust gasket (2)	--	93*-ALL	93*-ALL	--
26	65328-83	CLAMP, exhaust manifold (2)	--	93*-ALL	93*-ALL	--
27	65380-85	MUFFLER, rear	--	--	93*-BL	--
	65380-90	MUFFLER (rear - BK; 2 - BM)	--	--	93*-BK/M	--
	65381-89A	MUFFLER (rear - fishtail -BJ; 2-BN)	--	--	93*-BJ/N	--
28	65401-86	EXHAUST PIPE, front	--	--	93*-BJ/K/L	--
	65483-89	EXHAUST PIPE,	--	--	93*-BM/N	--
29	65410-83	SHIELD, crossover pipe	--	93*-ALL	93*-BJ/K/L	--
	65475-89	SHIELD, crossover pipe	--	--	93*-BM/N	--
30	65411-80A	CLAMP, crossover pipe	--	--	93*-BJ/K/L	--
31	65432-89	SHIELD, front muffler	--	--	93*-BM/N	--
	65447-86	SHIELD, front muffler	--	--	93*-BJ	--
32	65459-84A	SUPPORT TUBE	--	--	93*-ALL	--
33	65464-89	SHIELD, rear exhaust & muffler	--	--	93*-BM/N	--
34	65487-89	EXHAUST PIPE, rear	--	--	93*-BM/N	--
	65603-86	EXHAUST PIPE, rear	--	--	93*-BJ/K/L	--
35	65492-91	SUPPORT TUBE	--	--	93*-BM/N	--
36	65522-91	MUFFLER SUPPORT, rear	--	--	93*-BM/N	--
37	65571-82	SHIELD, front muffler	--	93*-ALL	--	--

FLT MODELS

FLHTC
FLTC-U
FLHTC-U
FLHS
FLHR

DJ
DM
DP
FA
FD

FXR MODELS

FXR
FXRS-SP
FXLR
FXRS-CON
EA
EG
EL
EM

SOFTAIL MODELS

FLSTC
FXSTC
FXSTS
FLSTF
FLSTN
BJ
BK
BL
BM
BN

DYNA MODELS

FXDL
FXDWG
FXDS-CON
GD
GE
GG

EXHAUST SYSTEM - FXR & SOFTAIL

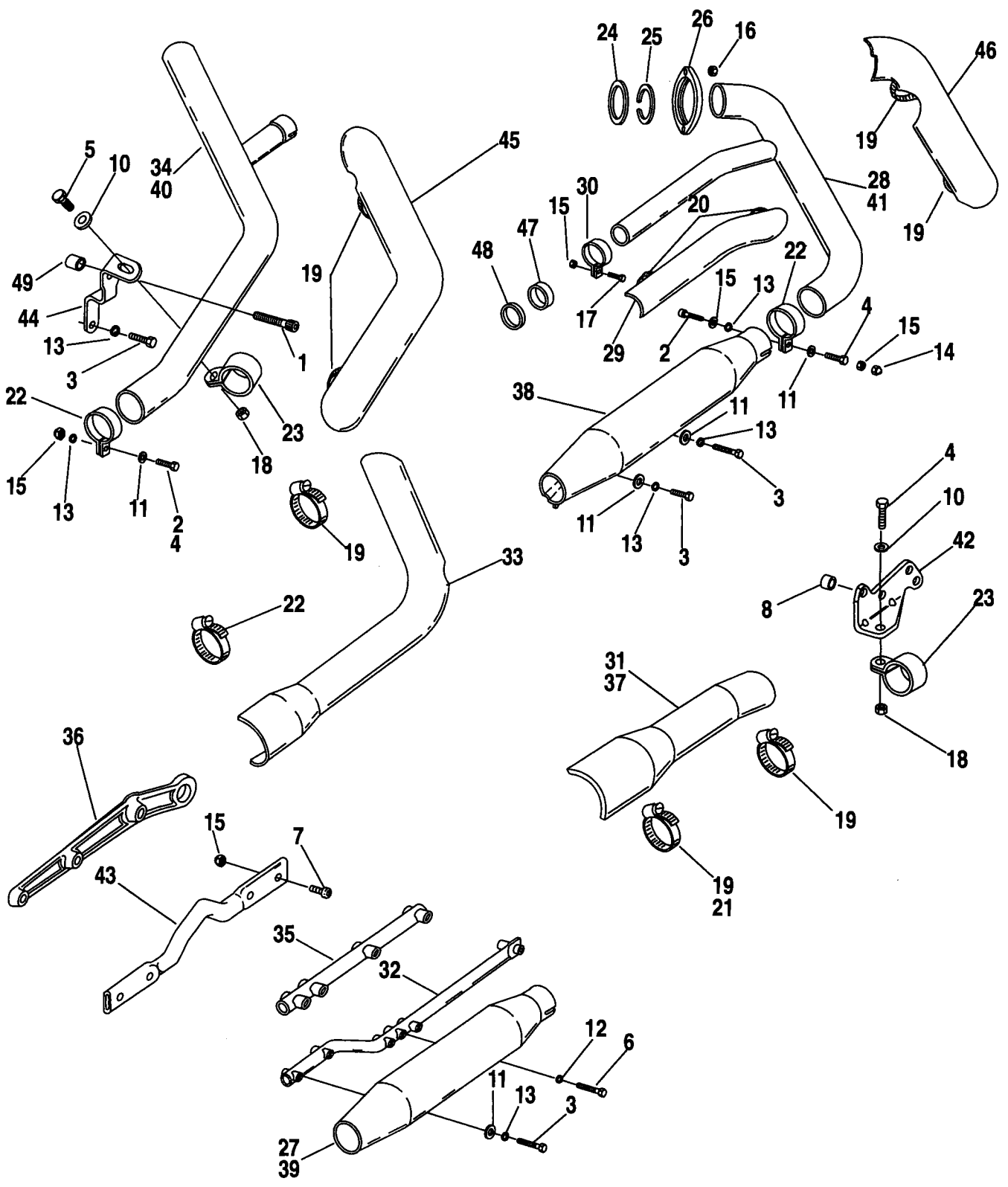

INDEX NO.	PART NO.	DESCRIPTION	FLT MODELS	FXR MODELS	SOFTAIL MODELS	DYNA MODELS
38	65689-89	MUFFLER, front - fishtail	--	--	93*-BJ	--
	65699-86	MUFFLER, front	--	--	93*-BJ/L	--
	65699-90	MUFFLER, front	--	--	93*-BK	--
	65747-87	MUFFLER, front	--	93*-ALL	--	--
39	65657-87	MUFFLER, rear	--	93*-ALL	--	--
40	65668-87	EXHAUST PIPE, rear (chrome)	--	93*-ALL	--	--
41	65669-87	EXHAUST PIPE, front (chrome)	--	93*-ALL	--	--
42	65670-82B	BRACKET, front exhaust	--	93*-ALL	--	--
43	65674-87	SUPPORT, muffler	--	93*-ALL	--	--
44	65675-87	BRACKET, rear exhaust	--	93*-ALL	--	--
45	65702-86	SHIELD, rear exhaust	--	93*-ALL	93*-BJ/K/L	--
46	65732-86	SHIELD, front exhaust	--	93*-ALL	93*-ALL	--
47	65781-82	GASKET	--	93*-ALL	93*-BM/N	--
48	65782-82	WASHER, exhaust	--	93*-ALL	93*-BM/N	--
49	65802-90	SPACER	--	93*-ALL	--	--
H-D INTERNATIONAL ONLY						
	52103-31	SPACER, muffler extension (HDI only)	--	--	93*-ALL	--
	65190-84	EXTENSION, front muffler (HDI only)	--	--	93*-ALL	--
27	65382-89C	MUFFLER, rear (2 - BM/N) (HDI only)	--	--	93*-ALL	--
	65714-91	TAPE, catalytic muffler (2-BM/N) (Swiss only)	--	--	93*-ALL	--
	65716-91	TAPE, catalytic muffler (Swiss only)	--	--	93*-BJ/K/L	--
	65867-91	MUFFLER, rear (catalytic) (Swiss only) (2 - BM/N)	--	--	93*-ALL	--
39	65739-89B	MUFFLER, rear (HDI only)	--	93*-ALL	--	--
38	65395-89B	MUFFLER, front (HDI only)	--	--	93*-BJ/K/L	--
	65738-89B	MUFFLER, front (HDI only)	--	93*-ALL	--	--
	65866-91	MUFFLER, front (catalytic) (Swiss only)	--	--	93*-BJ/K/L	--
	65813-91	HEAT SHIELD (2 - BK/L) (Swiss only)	--	--	93*-BJ/K/L	--
	65814-91	HEAT SHIELD (2) (Swiss only)	--	--	93*-BM/N	--
	65821-90	EXHAUST SHIELD KIT (Germany)	--	--	93*-BM	--

FLT MODELS

FLHTC DJ
 FLTC-U DM
 FLHTC-U DP
 FLHS FA
 FLHR FD

FXR MODELS

FXR EA
 FXRS-SP EG
 FXLR EL
 FXRS-CON EM

SOFTAIL MODELS

FLSTC BJ
 FXSTC BK
 FXSTS BL
 FLSTF BM
 FLSTN BN

DYNA MODELS

FXDL GD
 FXDWG GE
 FXDS-CON GG

EXHAUST SYSTEM - DYNA

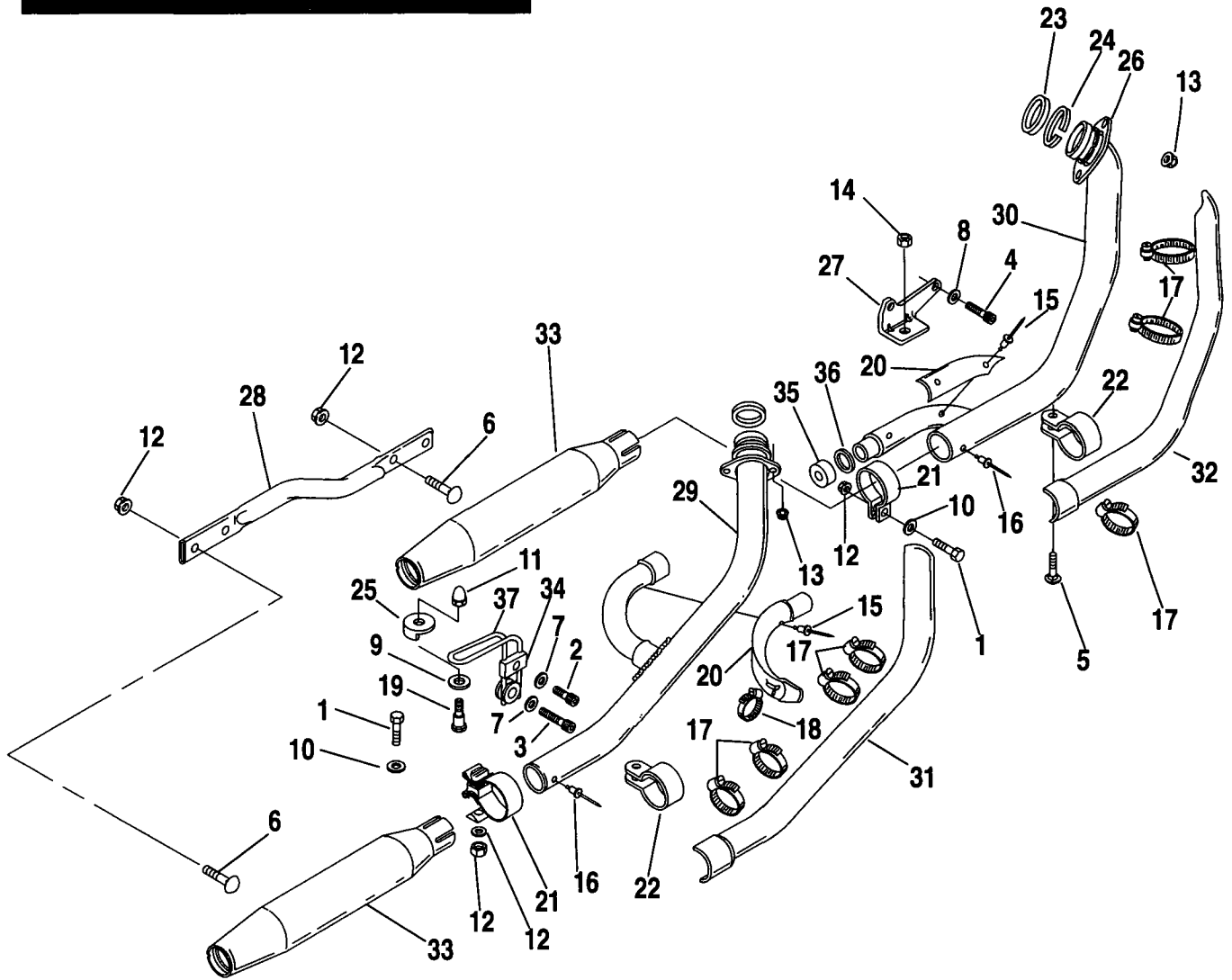

INDEX NO.	PART NO.	DESCRIPTION	FLT MODELS	FXR MODELS	SOFTAIL MODELS	DYNA MODELS
1	2818	SCREW (2)	--	--	--	93-ALL
2	3210A	SCREW	--	--	--	93*-ALL
3	3485A	SCREW	--	--	--	93*-ALL
4	4718A	SCREW, w/ washer (3)	--	--	--	93*-ALL
5	5414	BOLT, carriage	--	--	--	93*-ALL
6	5445W	BOLT, carriage (4)	--	--	--	93*-ALL
7	6016	WASHER (2)	--	--	--	93*-ALL
8	6099	WASHER (3)	--	--	--	93*-ALL
9	6701	WASHER	--	--	--	93*-ALL
10	6702	WASHER (2)	--	--	--	93-ALL
11	7507	ACORN NUT	--	--	--	93*-ALL
12	7531	NUT, flange (6; 4-1994 & later)	--	--	--	93*-ALL
13	7593	NUT, flange lock (4)	--	--	--	93*-ALL
14	7862	NUT	--	--	--	93*-ALL
15	8204	RIVET (4)	--	--	--	93*-ALL
16	8672	RIVET (2)	--	--	--	93-ALL
17	9955	CLAMP (7)	--	--	--	93*-ALL
18	10119	CLAMP (4)	--	--	--	93*-ALL
19	65192-90	BOLT, shoulder	--	--	--	93*-ALL
20	65213-92	SHIELD KIT w/#18	--	--	--	93*-ALL
21	65276-62	CLAMP, muffler (2)	--	--	--	93-ALL
	65283-94	CLAMP KIT w/ hardware	--	--	--	94*-ALL
22	65302-82	CLAMP, exhaust pipe (2)	--	--	--	93*-ALL
23	65324-83A	GASKET, exhaust port (2)	--	--	--	93*-ALL
24	65325-83	RETAINING RING, exhaust gasket (2)	--	--	--	93*-ALL
25	65327-93	CUP WASHER	--	--	--	93*-ALL
26	65328-83	FLANGE, exhaust manifold	--	--	--	93*-ALL
27	65670-90A	EXHAUST BRACKET, front	--	--	--	93*-ALL
28	65674-90A	SUPPORT, muffler	--	--	--	93*-ALL
29	65668-90	EXHAUST PIPE, rear	--	--	--	93*-ALL
30	65669-90	EXHAUST PIPE, front	--	--	--	93*-ALL
31	65701-90	SHIELD, rear exhaust	--	--	--	93*-ALL
32	65746-90A	SHIELD, front exhaust	--	--	--	93*-ALL
33	65747-90A	MUFFLER KIT w/ clamp & hardware (2)	--	--	--	93*-ALL
34	65824-90	CLAMP BLOCK	--	--	--	93*-ALL
35	65826-90A	GASKET, interconnect	--	--	--	93*-ALL
36	65827-90	RING, gasket retaining	--	--	--	93*-ALL
37	65828-90	BRACKET, rear exhaust	--	--	--	93*-ALL
H-D INTERNATIONAL ONLY						
33	65374-90C	MUFFLER KIT w/ clamp & hdwr.(2) (HDI only)	--	--	--	93*-ALL
	65868-91	MUFFLER (catalytic) (2) (Swiss only)	--	--	--	93*-ALL
	65716-91	TAPE, catalytic muffler (2) (Swiss only)	--	--	--	93-ALL

FLT MODELS

FLHTC DJ
 FLTC-U DM
 FLHTC-U DP
 FLHS FA
 FLHR FD

FXR MODELS

FXR EA
 FXRS-SP EG
 FXLR EL
 FXRS-CON EM

SOFTAIL MODELS

FLSTC BJ
 FXSTC BK
 FXSTS BL
 FLSTF BM
 FLSTN BN

DYNA MODELS

FXDL GD
 FXDWG GE
 FXDS-CON GG

BATTERY

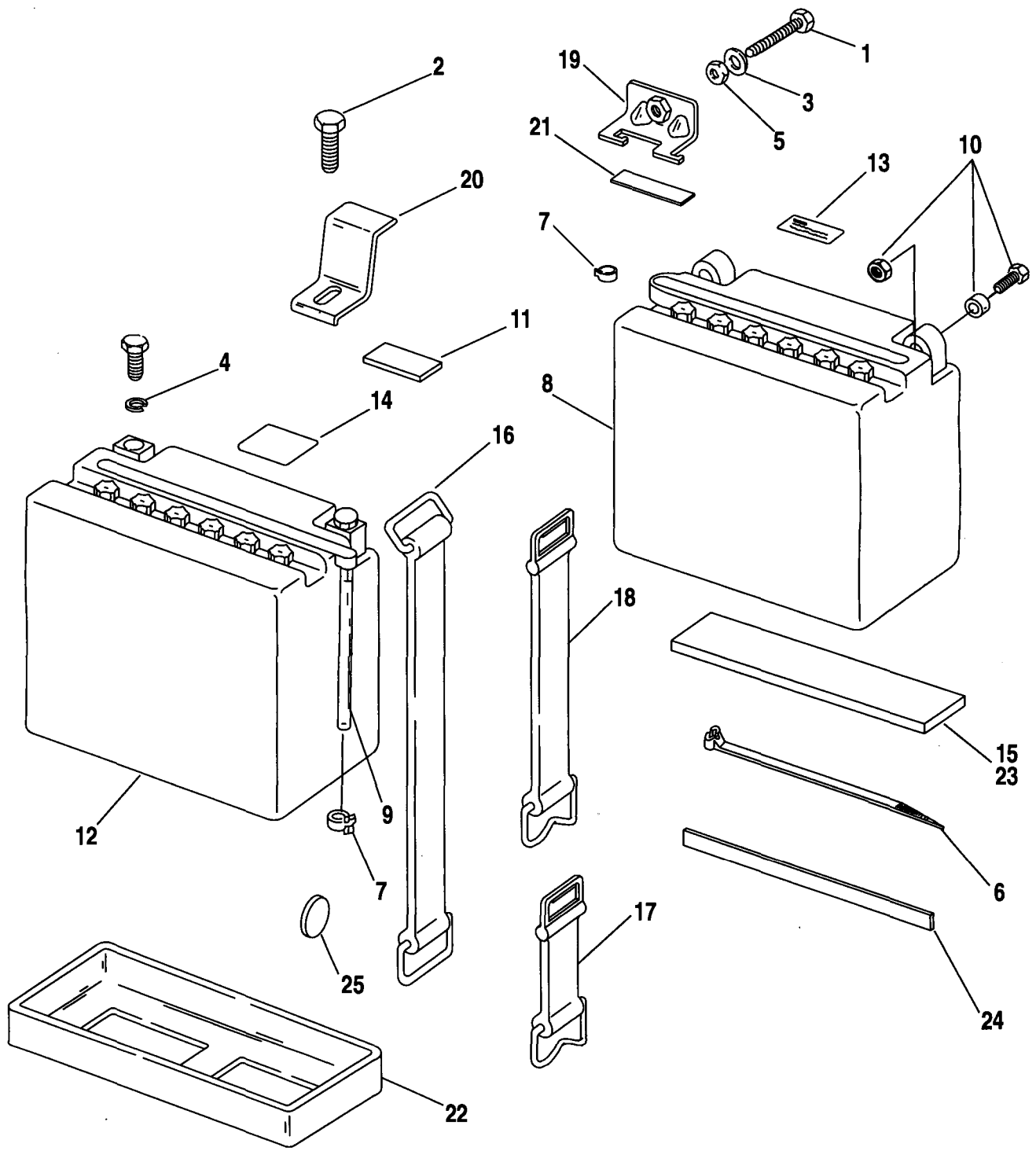

INDEX NO.	PART NO.	DESCRIPTION	FLT MODELS	FXR MODELS	SOFTAIL MODELS	DYNA MODELS
1	2796W	BOLT	--	93*-ALL	--	--
2	3574	SCREW	93*-ALL	--	--	--
3	6703	WASHER	--	93*-ALL	--	--
4	7229W	LOCKWASHER (2)	93*-ALL	--	--	--
5	7689W	NUT	--	93*-ALL	--	--
6	10039	CABLE STRAP	--	93*-ALL	--	--
7	10067	CLAMP	93*-ALL	93*-ALL	93*-ALL	--
8	65991-82A	BATTERY	--	93*-ALL	--	--
	65989-90A	BATTERY	--	--	93*-ALL	93*-ALL
9	65995-88A	VENT TUBE	93*-ALL	93*-ALL	93*-ALL	93*-ALL
10	66000-80	BATTERY TERMINAL KIT	--	93*-ALL	93*-ALL	93*-ALL
11	66004-93	PAD, battery clamp	93*-ALL	--	--	--
12	66010-82A	BATTERYw/ #7 & 9	93*-ALL	--	--	--
13	66042-79A	WARNING LABEL	--	--	93*-ALL	93*-ALL
14	66043-93	DECAL, battery vent	93*-ALL	--	--	--
15	66104-84	CUSHION (2)	--	93*-ALL	--	--
16	66105-77	BATTERY STRAP	--	--	E93-ALL	--
17	66109-93	BATTERY STRAP, front	--	--	L93*-ALL	--
18	66111-93	BATTERY STRAP, rear	--	--	L93*-ALL	--
19	66183-82	BRACKET, battery tie down	--	93*-ALL	--	--
20	66185-93	CLAMP, battery	93*-ALL	--	--	--
21	66188-82A	CUSHION	--	93*-ALL	--	--
22	66210-85B	CUSHION	--	--	93*-ALL	--
23	66309-84	CUSHION	--	--	93*-ALL	--
24	67067-76	ISOLATOR	--	93*-ALL	--	--
25	75101-82	SPACER	--	--	E93-ALL	--

FLT MODELS

FLHTC DJ
 FLTC-U DM
 FLHTC-U DP
 FLHS FA
 FLHR FD

FXR MODELS

FXR EA
 FXRS-SP EG
 FXLR EL
 FXRS-CON EM

SOFTAIL MODELS

FLSTC BJ
 FXSTC BK
 FXSTS BL
 FLSTF BM
 FLSTN BN

DYNA MODELS

FXDL GD
 FXDWG GE
 FXDS-CON GG

BATTERY TRAY - FLT

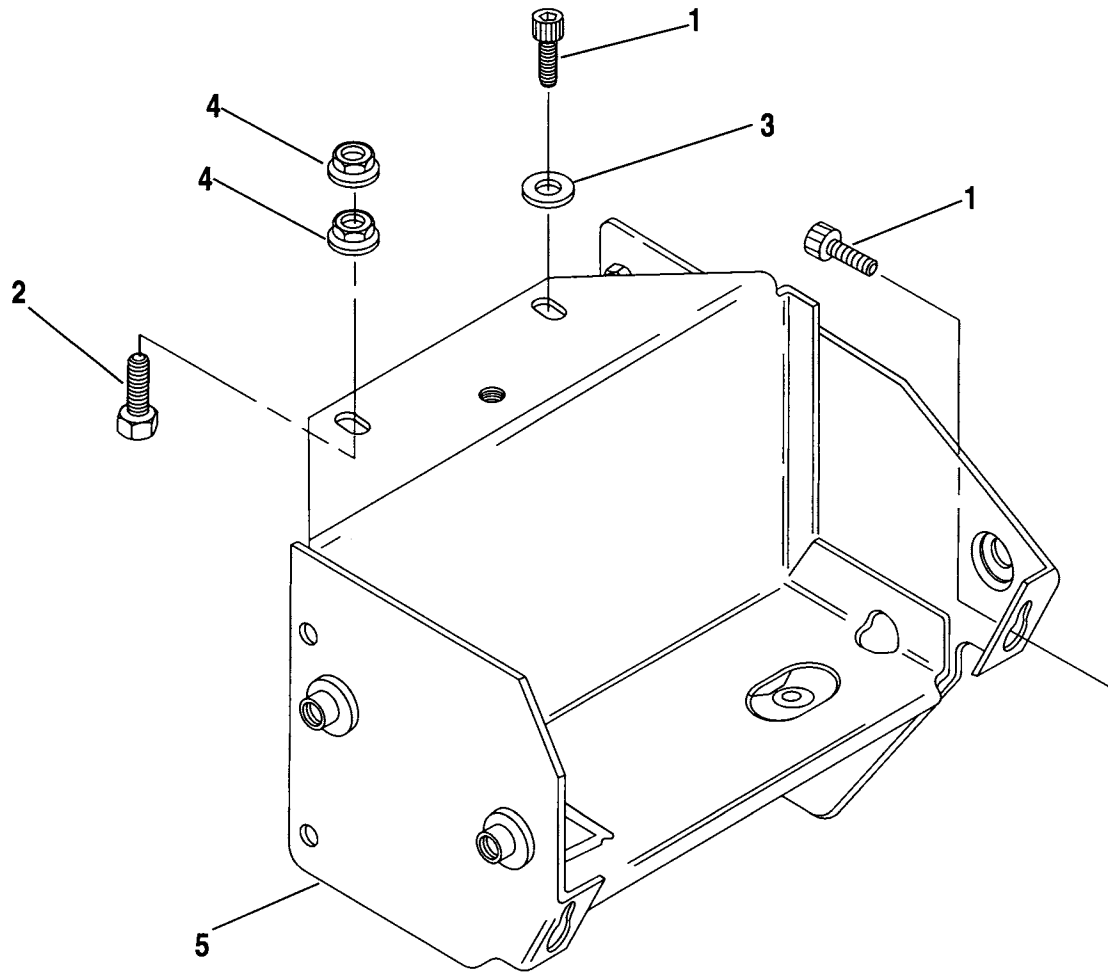

INDEX NO.	PART NO.	DESCRIPTION	FLT MODELS	FXR MODELS	SOFTAIL MODELS	DYNA MODELS
1	3255	SCREW (2; 4-late 1993 & later)	93*-ALL	--	--	--
2	4069A	SCREW (2)	93*-ALL	--	--	--
3	6703	WASHER (2)	93*-ALL	--	--	--
4	7716	FLANGE LOCKNUT (3)	E93-ALL	--	--	--
5	66281-93A	BATTERY TRAY ASM.	93*-ALL	--	--	--

FLT MODELS

FLHTC DJ
 FLTC-U DM
 FLHTC-U DP
 FLHS FA
 FLHR FD

FXR MODELS

FXR EA
 FXRS-SP EG
 FXLR EL
 FXRS-CON EM

SOFTAIL MODELS

FLSTC BJ
 FXSTC BK
 FXSTS BL
 FLSTF BM
 FLSTN BN

DYNA MODELS

FXDL GD
 FXDWG GE
 FXDS-CON GG

BATTERY TRAY — DYNA

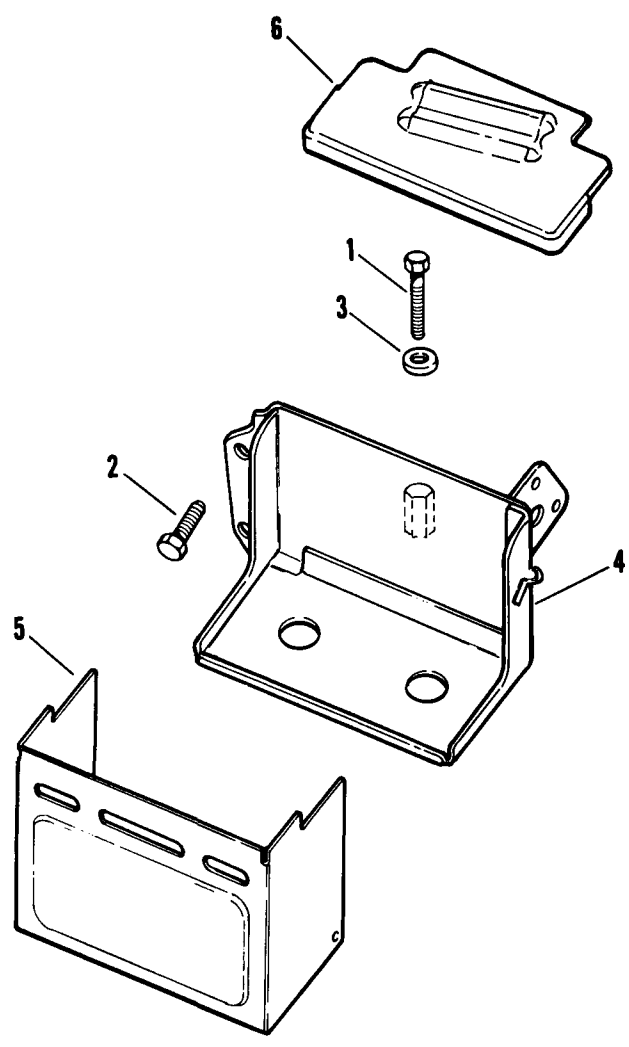

INDEX NO.	PART NO.	DESCRIPTION	FLT MODELS	FXR MODELS	SOFTAIL MODELS	DYNA MODELS
1	4086	SCREW	--	--	--	93*-ALL
2	4383	SCREW (2)	--	--	--	93*-ALL
3	6016	WASHER	--	--	--	93*-ALL
4	47132-93	TRAY, battery	--	--	--	93*-ALL
5	66347-91	SIDE COVER, battery (chrome)	--	--	--	93*-ALL
6	66368-90	TOP COVER, battery (chrome)	--	--	--	93*-ALL

FLT MODELS

FLHTC DJ
 FLTC-U DM
 FLHTC-U DP
 FLHS FA
 FLHR FD

FXR MODELS

FXR EA
 FXRS-SP EG
 FXLR EL
 FXRS-CON EM

SOFTAIL MODELS

FLSTC BJ
 FXSTC BK
 FXSTS BL
 FLSTF BM
 FLSTN BN

DYNA MODELS

FXDL GD
 FXDWG GE
 FXDS-CON GG

INSTRUMENTS - FLT

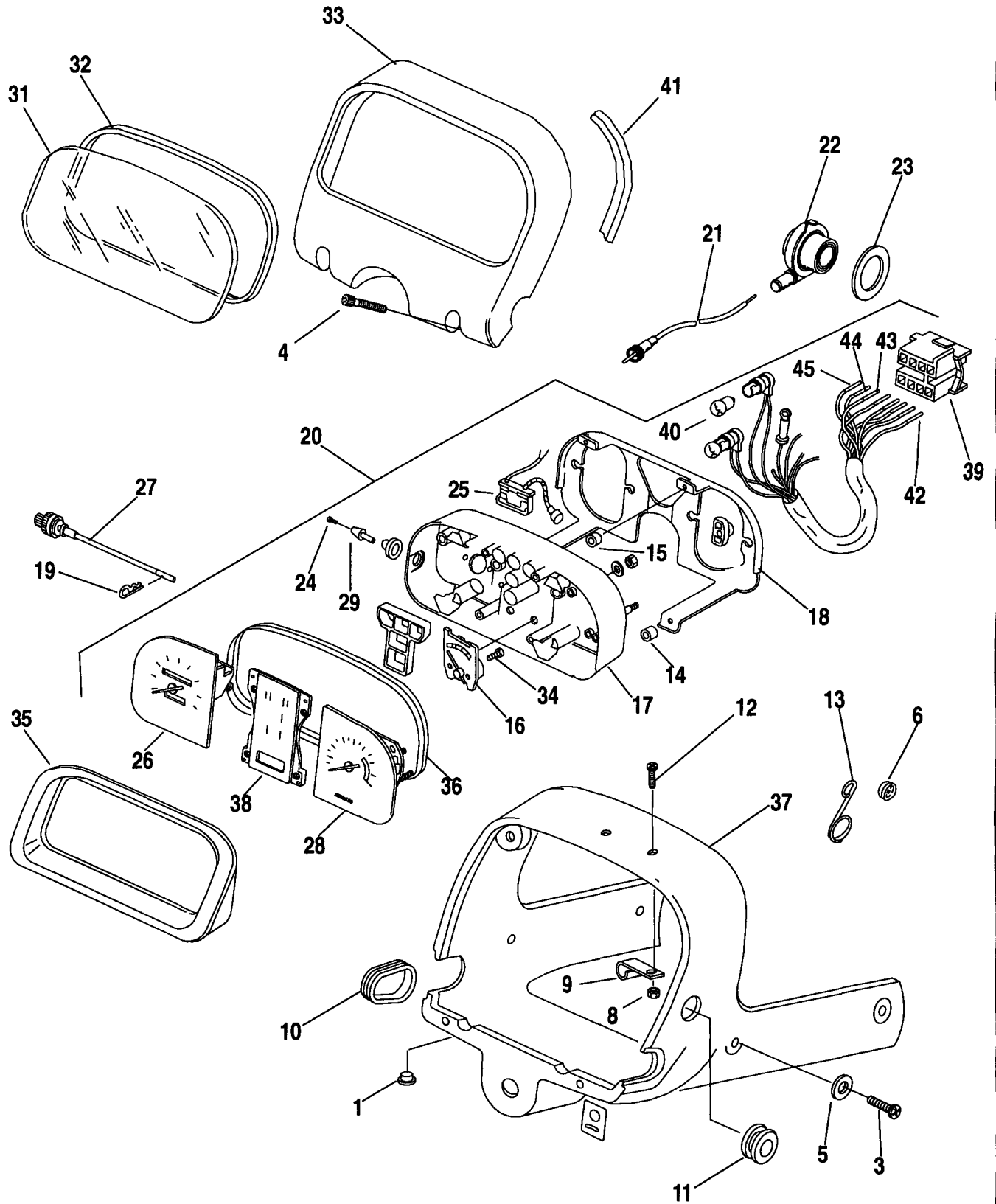

INDEX NO.	PART NO.	DESCRIPTION	FLT MODELS	FXR MODELS	SOFTAIL MODELS	DYNA MODELS
1	729	PLUG (3)	93-DM,FA	--	--	--
3	3996	SCREW (4)	93*-DM	--	--	--
4	4069A	SCREW (2)	93-DM,FA; 94*-DM	--	--	--
5	6702	WASHER (4)	93*-DM	--	--	--
6	6703	WASHER (3)	93-DM,FA; 94*-DM	--	--	--
8	7629	NUT (2)	93-DM,FA; 94*-DM	--	--	--
9	10091	CLIP (2)	93-DM,FA; 94*-DM	--	--	--
9A	10103	CLIP, adhesive back (3)	94*-DM	--	--	--
10	11454	GROMMET, handlebar (2)	93-DM,FA; 94*-DM	--	--	--
11	11477	PLUG	93*-DM	--	--	--
12	42534-90	SCREW (2)	93-DM,FA; 94*-DM	--	--	--
13	45092-66A	GUIDE, speedometer cable	93-DM,FA; 94*-DM	--	--	--
14	58355-86	SPACER (2)	93*-DJ/P	--	--	--
15	58356-86	SPACER (2)	93*-DJ/P	--	--	--
16	61631-84	FUEL GAUGE	93-ALL; 94*-DJ/M/P	--	--	--
17	66997-86A	CASE, instrument	93-ALL; 94*-DJ/M/P	--	--	--
18	66998-86	BRACKET, instrument mounting	93*-DJ/P	--	--	--
19	66999-86	CLIP	93*-DJ/P	--	--	--
20	67000-85E	INSTRUMENT PANEL ASSEMBLY, mph	93-DM,FA	--	--	--
	67000-94	INSTRUMENT PANEL ASSEMBLY, mph	94*-DM	--	--	--
	67003-86D	INSTRUMENT PANEL ASSEMBLY, mph	93-DJ/P	--	--	--
	67003-94	INSTRUMENT PANEL ASSEMBLY, mph	94*-DJ/P	--	--	--
	67023-84F	INSTRUMENT PANEL ASSEMBLY, kph	93-DM,FA	--	--	--
	67023-94	INSTRUMENT PANEL ASSEMBLY, kph	94*-DM	--	--	--
21	67060-87A	CABLE ASSEMBLY, speedometer	93*-DJ/P	--	--	--
	67072-87B	CABLE ASSEMBLY, speedometer	93-DM,FA; 94*-DM	--	--	--
22	67073-87A	DRIVE UNIT, speedometer	93-ALL; 94*-DJ/M/P	--	--	--
23	67098-87	SEAL, drive unit	93-ALL; 94*-DJ/M/P	--	--	--
24	67117-85	SCREW	93-DM,FA; 94*-DM	--	--	--
25	67123-86B	REED SWITCH	93-ALL 94*-DJ/M/P	--	--	--

FLT MODELS
 FLHTC
 FLTC-U
 FLHTC-U
 FLHS
 FLHR

FXR MODELS
 DJ
 DM
 DP
 FA
 FD
 FXR
 FXRS-SP
 FXLR
 FXRS-CON
 EA
 EG
 EL
 EM

SOFTAIL MODELS
 FLSTC
 FXSTC
 FXSTS
 FLSTF
 FLSTN
 BJ
 BK
 BL
 BM
 BN

DYNA MODELS
 FXDL
 FXDWG
 FXDS-CON
 GD
 GE
 GG

INSTRUMENTS - FLT

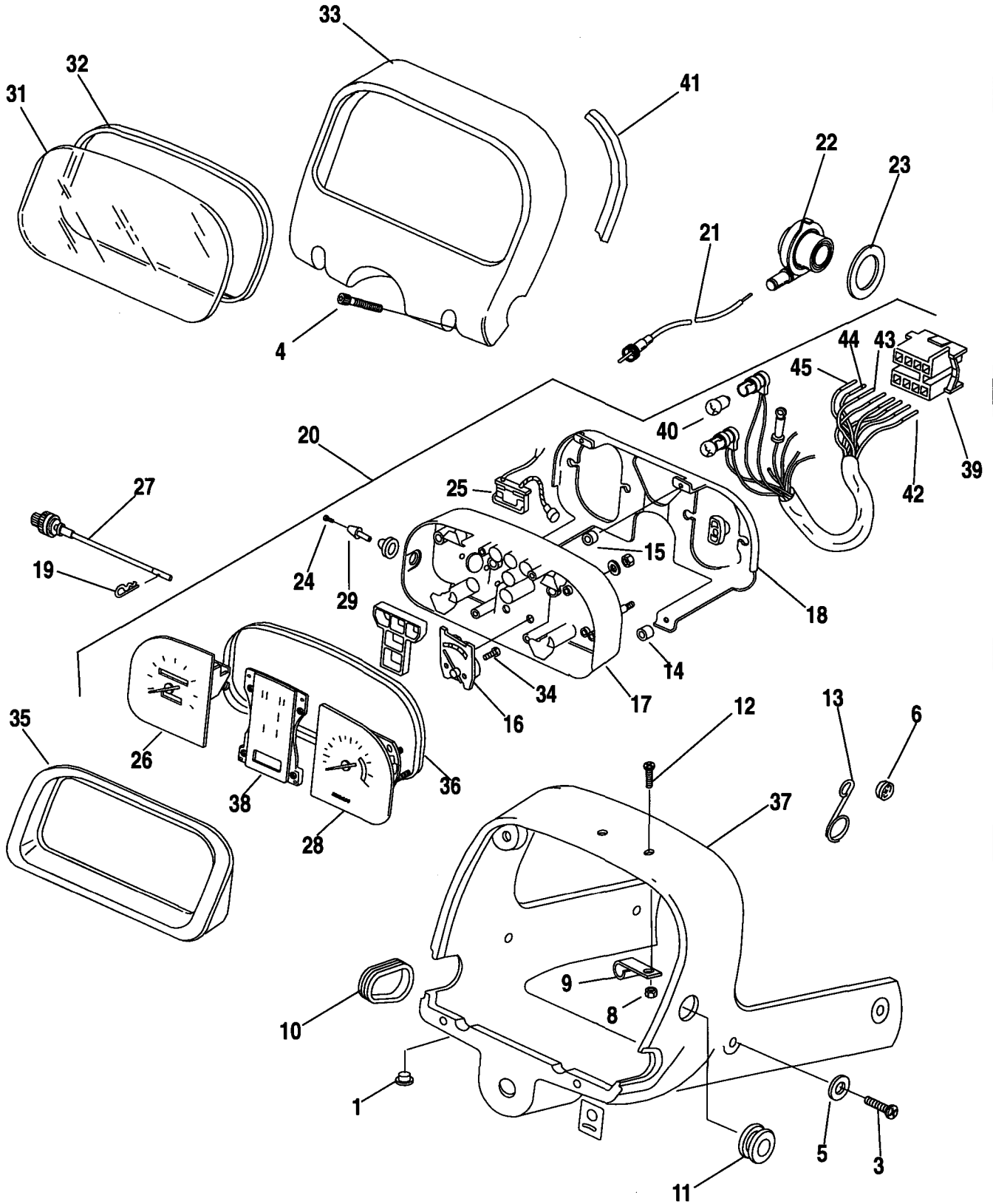

INDEX NO.	PART NO.	DESCRIPTION	FLT MODELS	FXR MODELS	SOFTAIL MODELS	DYNA MODELS
26	67211-86A	SPEEDOMETER, mph	93*-DJ/P	--	--	--
	67232-85A	SPEEDOMETER, mph	93-DM,FA; 94*-DM	--	--	--
27	67219-86	RESET CABLE, odometer	93*-DJ/P	--	--	--
28	67229-85	TACHOMETER	93-ALL; 94*-DJ/M/P	--	--	--
29	67234-84	RESET KNOB, odometer	93*-DM,FA 94*-DM	--	--	--
31	67236-80	LENS	93-DM,FA; 94*-DM	--	--	--
	67608-86	LENS	93*-DJ/P	--	--	--
32	67237-80	GASKET	93-DM,FA; 94*-DM	--	--	--
33	67238-80	CASE	93-DM,FA; 94*-DM	--	--	--
34	67243-84	SCREW (4-DJ/P)	93-ALL; 94*-DJ/M/P	--	--	--
35	67245-93	PLATE, reflecting	93-DM,FA; 94*-DM	--	--	--
36	67246-93	GASKET (white)	93-DM,FA; 94*-DM	--	--	--
37	67800-93A	DASH PANEL SUPPORT	93-DM,FA; 94*-DM	--	--	--
38	68459-84B	PANEL, indicator lights	93-DM,FA; 94*-DM	--	--	--
39	70287-81	CONNECTOR, eight socket	93-ALL; 94*-DJ/M/P	--	--	--
40	71099-74	BULB, instrument panel (4)	93-ALL; 94*-DJ/M/P	--	--	--
41	71296-93	EDGING, speedometer	93-DM,FA; 94*-DM	--	--	--
42	72038-71	SOCKET, single pin (12)	93-ALL; 94*-DJ/M/P	--	--	--
43	72039-71	PIN, single socket	93-ALL	--	--	--
44	72043-71	CONNECTOR, single pin	93-ALL	--	--	--
45	72044-71	CONNECTOR, single socket	93-ALL	--	--	--

H-D INTERNATIONAL ONLY

20	67028-86A	INSTRUMENT PANEL ASM., kph (HDI only)	93-DJ/P	--	--	--
	67028-94	INSTRUMENT PANEL ASM., kph (HDI only)	94*-DJ/P	--	--	--
26	67216-86B	SPEEDOMETER, kph (HDI only)	93*-DJ/P	--	--	--
	67233-80D	SPEEDOMETER, kph (HDI only)	93-DM/FA; 94*-DM	--	--	--
38	68460-82	PANEL, indicator lights (HDI only)	93-DM,FA; 94*-DM	--	--	--

FLT MODELS

FLHTC
FLTC-U
FLHTC-U
FLHS
FLHR

DJ
DM
DP
FA
FD

FXR MODELS

FXR
FXRS-SP
FXLR
FXRS-CON

EA
EG
EL
EM

SOFTAIL MODELS

FLSTC
FXSTC
FXSTS
FLSTF
FLSTN

BJ
BK
BL
BM
BN

DYNA MODELS

FXDL
FXDWG
FXDS-CON

GD
GE
GG

**INSTRUMENTS - FXRS-CON,
FXRS-SP,FXDL & FXDS-CON**

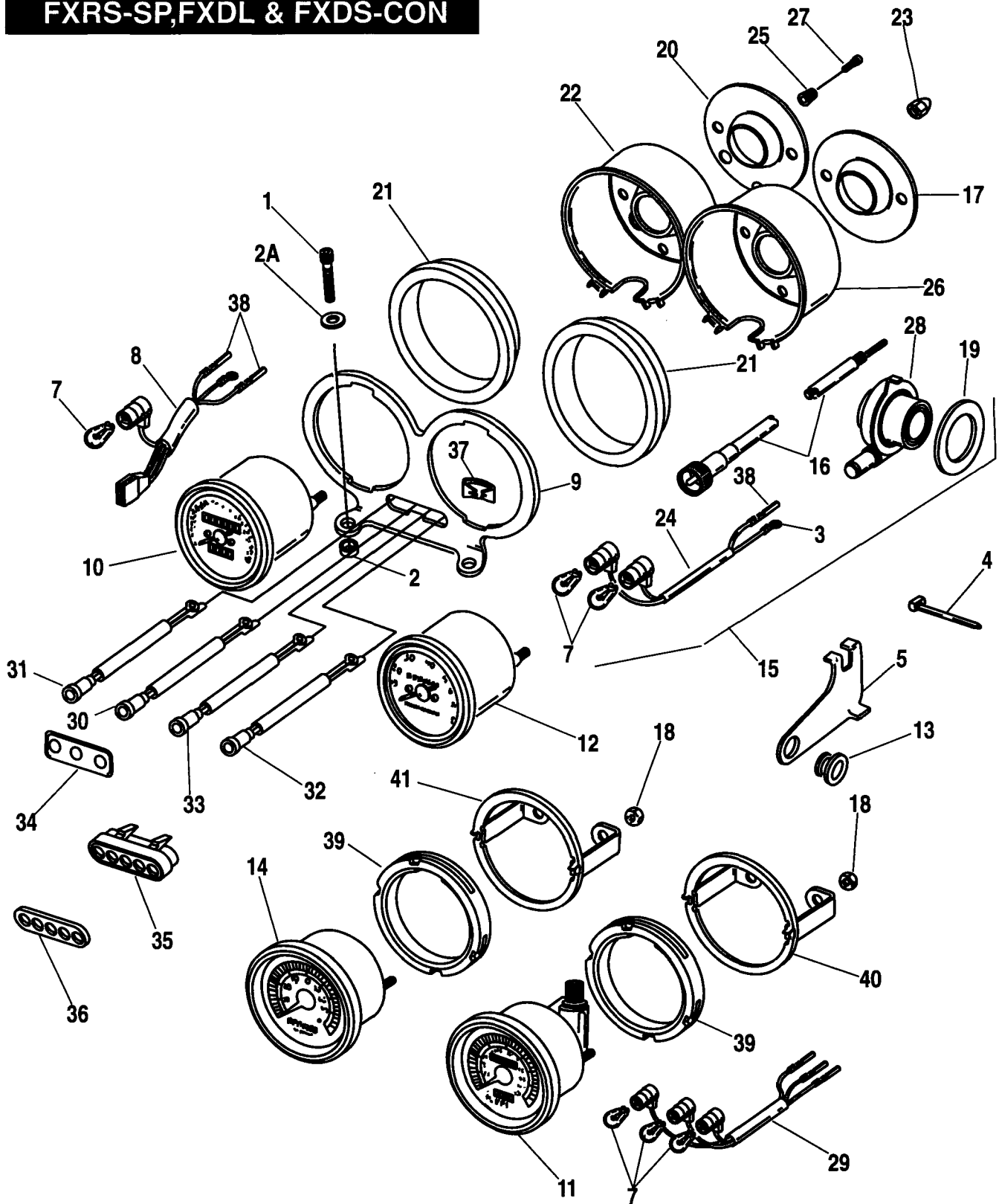

INDEX NO.	PART NO.	DESCRIPTION	FLT MODELS	FXR MODELS	SOFTAIL MODELS	DYNA MODELS
1	853A	SCREW (2)	--	93*-EG/M	--	94*-GG
2	5736	SPACER (2)	--	93*-EG/M	--	94*-GG
2A	6702	WASHER	--	--	--	94*-GG
3	9857	TERMINAL, ring type #10 hole (2)	--	93*-EG/M	--	--
4	10081	CABLE STRAP, double loop	--	93*-EG/M	--	--
5	45094-92	CABLE GUIDE	--	93*-EG/M	--	93*-GD
7	53439-79	BULB (3)	--	93*-EG/M	--	93*-GD/G
8	67034-83	BULB & SOCKET, w/ terminals - tachometer	--	93*-EG/M	--	--
9	67110-92	BRACKET, mounting	--	93*-EG/M	--	94*-GG
10	67037-91	SPEEDOMETER - mph	--	93*-EG/M	--	--
	67206-94	SPEEDOMETER - mph	--	--	--	94*-GG
11	67168-88A	SPEEDOMETER - mph	--	--	--	93*-GD
12	67042-85	TACHOMETER, w/ wiring	--	93*-EG/M	--	--
	67207-94	TACHOMETER	-	--	--	94*-GG
13	67055-92	BUSHING	--	93*-EG/M	--	93*-GD/G
14	67171-88	TACHOMETER, w/ wiring	--	--	--	93*-GD
15	67046-92	SPEEDOMETER & TACHOMETER ASSEMBLY-- w/ bracket - mph	--	93*-EG/M	--	--
	71014-88A	SPEEDOMETER & TACHOMETER ASSEMBLY-- w/ housing - mph	--	--	--	93*-GD
16	67063-89	CABLE ASSEMBLY, speedometer	--	93*-EG/M	--	94*-GG
	67186-88	CABLE ASSEMBLY, speedometer	--	--	--	93*-GD
17	67085-83	TRIM, tachometer (chrome)	--	93*-EG/M	--	94*-GG
18	67094-85	NUT (4)	--	--	--	93*-GD
19	67098-87	SEAL, drive unit	--	93*-EG/M	--	93*-GD/G
20	67103-91	TRIM, speedometer (chrome)	--	93*-EG/M	--	94*-GG
21	67121-92	CUSHION, speedometer & tachometer mtg.	--	93*-EG/M	--	94*-GG
22	67105-91A	COVER, speedometer - lower (black)	--	93*-EG/M	--	94*-GG
23	67106-83	ACORN NUT (4)	--	93*-EG/M	--	94*-GG
24	67107-83	BULB & SOCKET, w/ terminals - speedometer	--	93*-EG/M	--	--
25	67108-83	RESET KNOB, odometer (chrome)	--	93*-EG/M	--	94*-GG
26	67112-83	COVER, tachometer - lower (black)	--	93*-EG/M	--	94*-GG
27	67117-85	SCREW, reset knob	--	93*-EG/M	--	94*-GG
28	67127-84A	DRIVE UNIT, speedometer	--	93*-EG/M	--	93*-GD/G
29	67172-88A	WIRING HARNESS	--	--	--	93*-GD
	67264-94	WIRING HARNESS	--	--	--	94*-GG
30	68024-92	INDICATOR LAMP, neutral (green)	--	93*-EG/M	--	93*-GD/G

FLT MODELS

FLHTC
FLTC-U
FLHTC-U
FLHS
FLHR

DJ
DM
DP
FA
FD

FXR MODELS

FXR
FXRS-SP
FXLR
FXRS-CON

EA
EG
EL
EM

SOFTAIL MODELS

FLSTC
FXSTC
FXSTS
FLSTF
FLSTN

BJ
BK
BL
BM
BN

DYNA MODELS

FXDL
FXDWG
FXDS-CON

GD
GE
GG

**INSTRUMENTS - FXRS-CON,
FXRS-SP,FXDL & FXDS-CON**

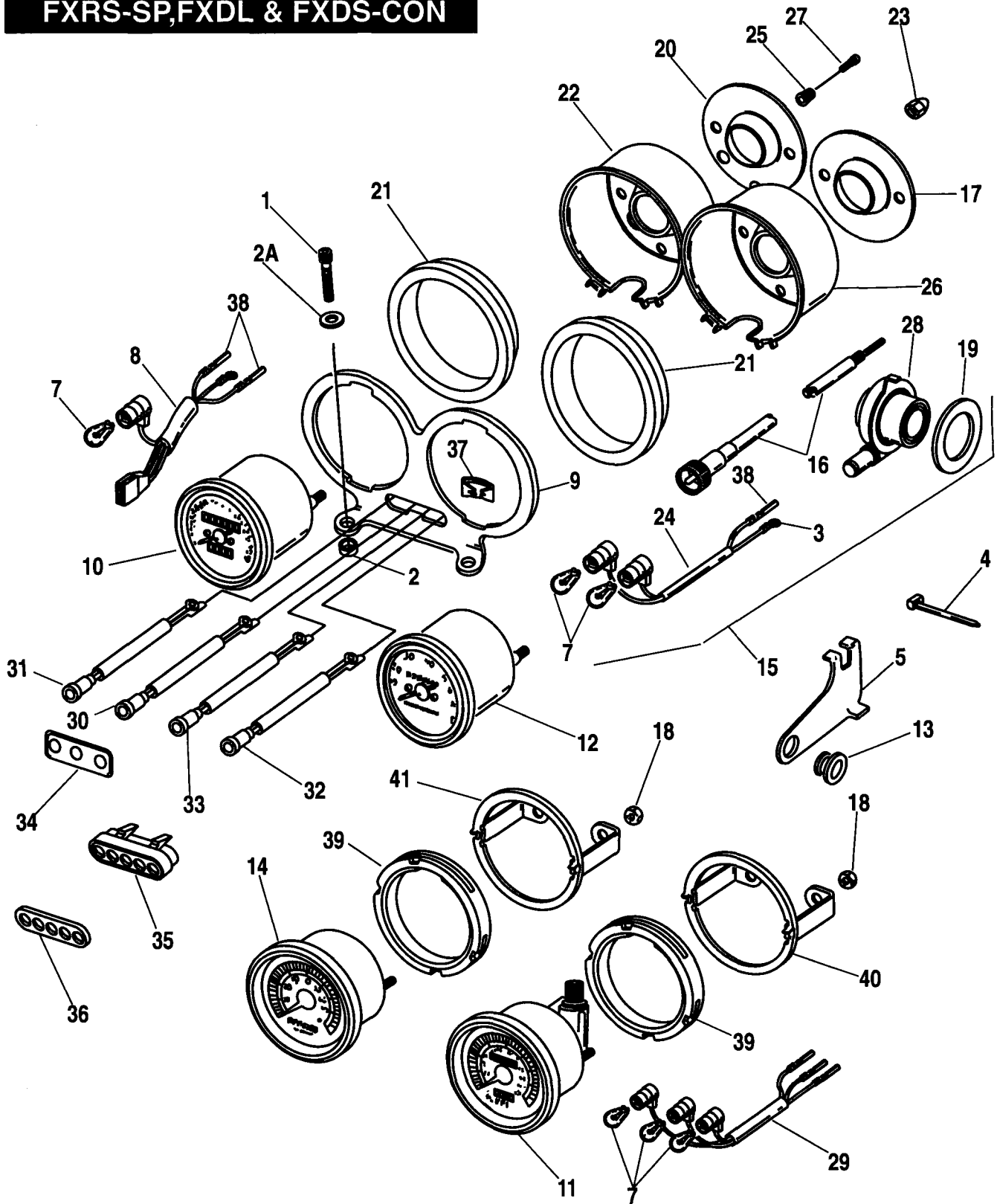

INDEX NO.	PART NO.	DESCRIPTION	FLT MODELS	FXR MODELS	SOFTAIL MODELS	DYNA MODELS
31	68597-86	INDICATOR LAMP, high beam (blue)	--	93*-EG/M	--	--
	68023-92	INDICATOR LAMP, high beam (blue)	--	93*-EG/M	--	93*-GD/G
32	68021-92	INDICATOR LAMP, turn signal (green) (2)	--	93*-EG/M	--	93*-GD/G
	68468-86	INDICATOR LAMP, turn signal (amber)	--	93*-EG/M	--	--
	68740-91	INDICATOR LAMP, turn signal (green)	--	93*-EG/M	--	--
33	68020-92	INDICATOR LAMP, oil pressure (red)	--	93*-EG/M	--	93*-GD/G
34	68464-86	TRIM, indicator lamps (black)	--	93*-EG/M	--	--
35	68513-92	BEZEL, indicator lamps	--	93*-EG/M	--	93*-GD/G
36	68516-92	TRIM, indicator lamps	--	--	--	93*-GD/G
37	68608-83	SPEED NUT (5)	--	93*-EG/M	--	93*-GD/G
38	72038-71	SOCKET, single pin (7;9-GG)	--	93*-EG/M	--	93*-GD/G
39	92061-83	CUSHION, speedometer & tachometer mtg. (2)	--	--	--	93*-GD
40	92079-88	BRACKET, speedometer	--	-	--	93*-GD
41	92080-88	BRACKET, tachometer	--	-	--	93*-GD
H-D INTERNATIONAL ONLY						
10	67041-91	SPEEDOMETER - kph (HDI only)	--	93*-EG/M	--	--
	67208-94	SPEEDOMETER - kph (HDI only)	--	--	--	94*-GG
11	67169-88A	SPEEDOMETER - kph (HDI only)	--	--	--	93*-GD
28	67187-88	DRIVE UNIT, speedometer (HDI only)	--	--	--	93*-GD/G

FLT MODELS

FLHTC DJ
 FLTC-U DM
 FLHTC-U DP
 FLHS FA
 FLHR FD

FXR MODELS

FXR EA
 FXRS-SP EG
 FXLR EL
 FXRS-CON EM

SOFTAIL MODELS

FLSTC BJ
 FXSTC BK
 FXSTS BL
 FLSTF BM
 FLSTN BN

DYNA MODELS

FXDL GD
 FXDWG GE
 FXDS-CON GG

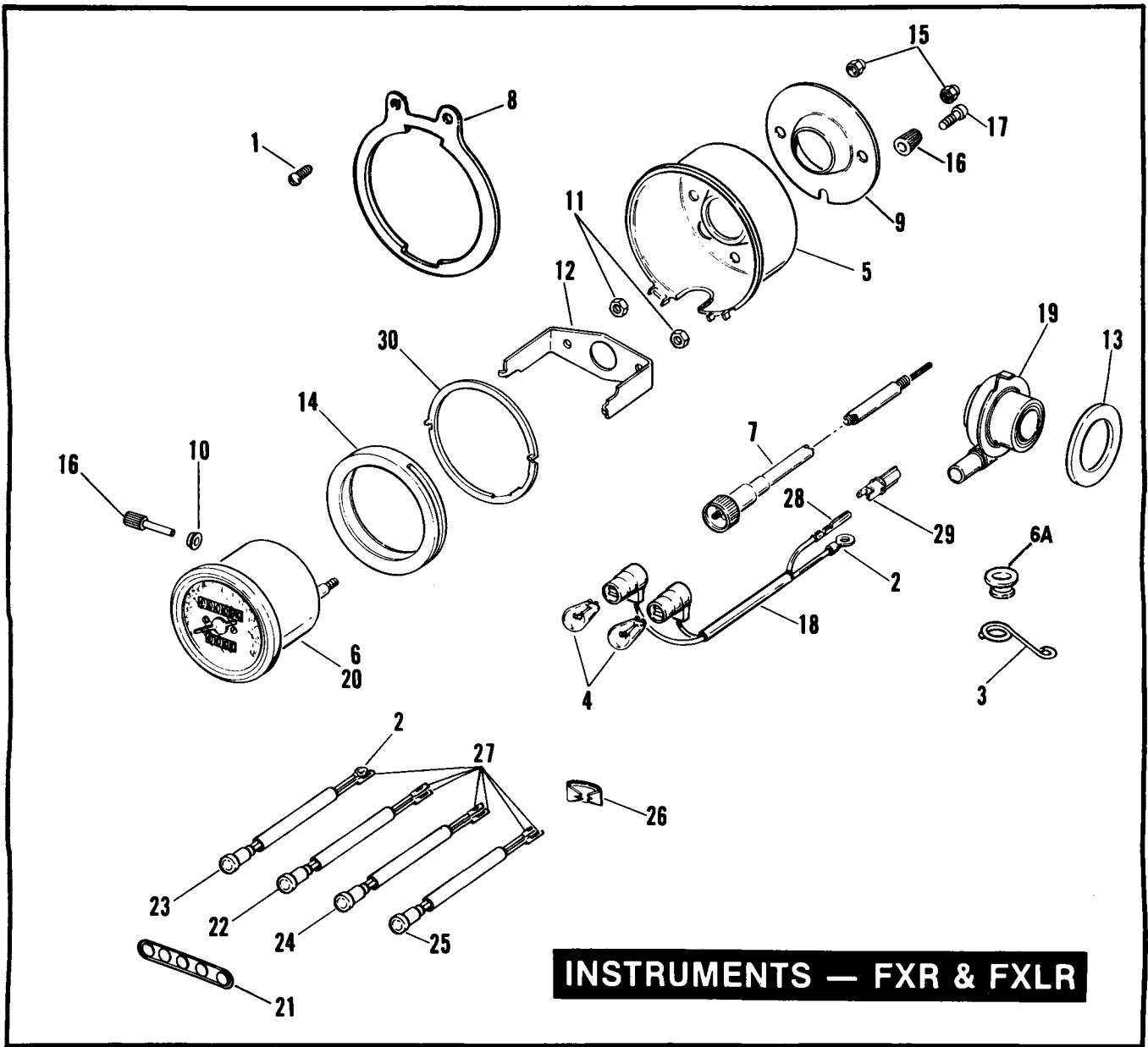

INSTRUMENTS — FXR & FXLR

INDEX NO.	PART NO.	DESCRIPTION	FLT MODELS	FXR MODELS	SOFTAIL MODELS	DYNA MODELS
1	923	SCREW (2)	--	93*-EL	--	--
2	9857	TERMINAL, ring type #10 hole	--	93*-EA	--	--
3	45094-92	GUIDE, cable	--	93*-EA/L	--	--
4	53439-79	BULB (2)	--	93*-EA/L	--	--
5	67014-91	COVER, speedometer (chrome)	--	93*-EL	--	--
6	67020-85A	SPEEDOMETER - mph	--	93*-EA	--	--
	67025-91	SPEEDOMETER, w/ wiring - mph	--	93*-EL	--	--
6A	67055-92	BUSHING	--	93*-EA/L	--	--
7	67078-85A	CABLE ASSEMBLY, speedometer	--	93*-EA/L	--	--
8	67080-87	MOUNTING BRACKET, speedometer	--	93*-EL	--	--
9	67085-83	TRIM, speedometer	--	93*-EL	--	--
	67103-91	ORNAMENT, speedometer	--	93*-EL	--	--
10	67086-85	GROMMET	--	93*-EA	--	--
11	67094-85	NUT (2)	--	93*-EA	--	--
12	67095-85	BRACKET, mounting	--	93*-EA	--	--
13	67098-87	SEAL, drive unit	--	93*-EA/L	--	--
14	67104-83	GASKET, speedometer mounting	--	93*-EL	--	--
	92061-83	GASKET, speedometer mounting	--	93*-EA	--	--
15	67106-83	ACORN NUT (2)	--	93*-EL	--	--
16	67108-83	RESET KNOB, odometer	--	93*-EL	--	--
	67122-85	RESET KNOB, odometer	--	93*-EA	--	--
17	67117-85	SCREW, reset knob	--	93*-EL	--	--
18	67126-91	BULB & SOCKET	--	93*-EL	--	--
	67202-91	BULB & SOCKET, w/ terminals	--	93*-EA	--	--
19	67127-84A	DRIVE UNIT, speedometer	--	93*-EA	--	--
	67132-85A	DRIVE UNIT, speedometer	--	93*-EL	--	--
20	67200-86A	SPEEDOMETER, w/ wiring - mph	--	93*-EA	--	--
21	67826-92	TRIM, indicator lamps	--	93*-EL	--	--
22	68024-92	INDICATOR LAMP, neutral (green)	--	93*-EA/L	--	--
23	68023-92	INDICATOR LAMP, high beam (blue)	--	93*-EA/L	--	--
24	68021-92	INDICATOR LAMP, turn signal (green) (2)	--	93*-EA/L	--	--
25	68020-92	INDICATOR LAMP oil pressure (red)	--	93*-EA/L	--	--
26	68608-83	SPEED NUT (4; 3 - EL)	--	93*-EA/L	--	--
27	72038-71	SOCKET, single pin	--	93*-EA	--	--
28	72039-71	PIN, single socket	--	93*-EA	--	--
29	72043-71	CONNECTOR, single pin	--	93*-EA	--	--
30	92070-86	PLATE, mounting	--	93*-EA	--	--
H-D INTERNATIONAL ONLY						
6	67018-91	SPEEDOMETER, w/ wiring - kph (HDI only)	--	93*-EL	--	--
	67021-85B	SPEEDOMETER - kph (HDI only)	--	93*-EA	--	--

FLT MODELS

FLHTC
FLTC-U
FLHTC-U
FLHS
FLHR

DJ
DM
DP
FA
FD

FXR MODELS

FXR
FXRS-SP
FXLR
FXRS-CON

EA
EG
EL
EM

SOFTAIL MODELS

FLSTC
FXSTC
FXSTS
FLSTF
FLSTN

BJ
BK
BL
BM
BN

DYNA MODELS

FXDL
FXDWG
FXDS-CON

GD
GE
GG

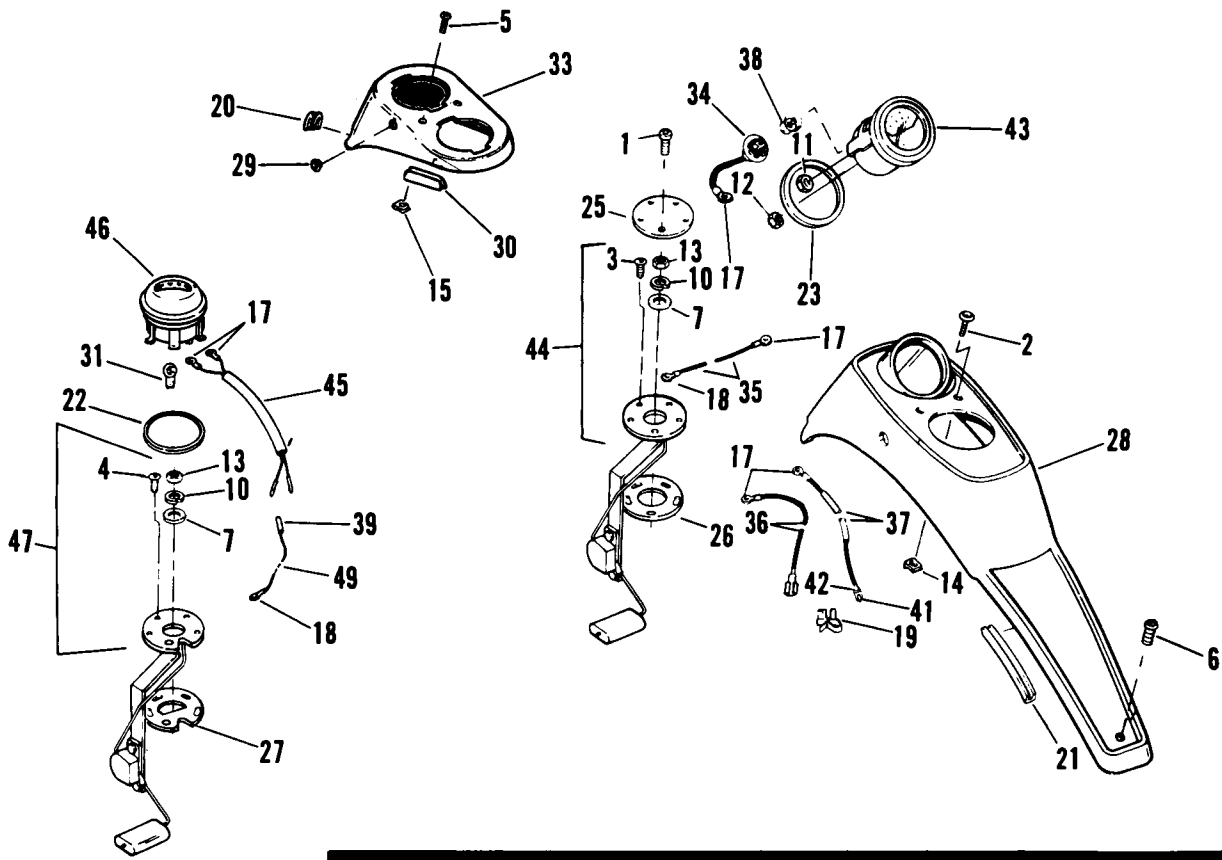

FUEL TANK INSTRUMENTS – FXR & FXDL

INDEX NO.	PART NO.	DESCRIPTION	FLT MODELS	FXR MODELS	SOFTAIL MODELS	DYNA MODELS
1	907	SCREW (5)	--	93*-EA	--	--
2	923	SCREW (2)	--	93*-EG/M	--	--
3	1309B	SCREW (5)	--	93*-EA/G/M	--	--
4	1311B	SCREW (5)	--	--	--	93*-GD
5	2519	SCREW (2)	--	--	--	93*-GD
6	3652	SCREW	--	93*-EA/G/M	--	--
7	6716	WASHER	--	93*-EA/G/M	--	--
10	7069	LOCKWASHER	--	93*-EA/G/M	--	--
11	7590	NUT (3)	--	93*-EA/G/M	--	--
12	7608	NUT (2)	--	93*-EA/G/M	--	--
13	7638	NUT	--	93*-EA/G/M	--	--
14	7743	CLIP NUT (2)	--	93*-EA/G/M	--	--
15	8108	CLIP NUT (2)	--	--	--	93*-GD
17	9856	TERMINAL, ring type - #6 hole (4)	--	93*-EA/G/M	--	93*-GD
18	9857	TERMINAL, ring type - #10 hole	--	93*-EA/G/M	--	93*-GD
19	9894	CLIP, ground wire	--	93*-EA/G/M	--	--
20	11452	GROMMET	--	--	--	93*-GD
21	61117-86	TRIM (2)	--	93*-EA/G/M	--	--
22	61192-88	GASKET, cap gauge	--	--	--	93*-GD
23	61311-82	GASKET, fuel gauge	--	93*-EA/G/M	--	--
25	61321-80	PLATE, cover	--	93*-EA	--	--
26	61322-80B	GASKET, fuel sending unit	--	93*-EA/G/M	--	--
27	61324-88	GASKET, fuel sending unit	--	--	--	93*-GD
28	61411-82	CONSOLE, fuel tank (chrome)	--	93*-EG/M	--	--
	61413-86	CONSOLE, fuel tank (black wrinkle)	--	93*-EA	--	--
29	67086-85	GROMMET	--	--	--	93*-GD
30	67119-85	TRIM	--	--	--	93*-GD
31	67136-85	BULB, fuel gauge	--	--	--	93*-GD
33	67185-88	INSTRUMENT HOUSING (black wrinkle)	--	--	--	93*-GD
34	69540-78	SOCKET w/ wire	--	93*-EA/G/M	--	--
35	69617-82	WIRE, sending unit to gauge	--	93*-EG/M	--	--
36	69618-82A	WIRE, fuel gauge ground	--	93*-EG/M	--	--
37	69619-82	WIRE, fuel gauge to harness	--	93*-EG/M	--	--
38	71099-74	BULB, fuel gauge	--	93*-EG/M	--	--
39	72038-71	SOCKET, single pin	--	--	--	93*-GD
41	72039-71	PIN, single socket	--	93*-EG/M	--	93*-GD
42	72043-71	CONNECTOR, single pin	--	93*-EG/M	--	93*-GD
43	75039-86	FUEL GAUGE	--	93*-EG/M	--	--
44	75034-82	SENDING UNIT	--	93*-EG/M	--	--
45	75047-88	HARNESS, fuel gauge	--	--	--	93*-GD
46	75049-88A	FUEL GAUGE	--	--	--	93*-GD
47	75062-90	SENDING UNIT	--	--	--	93*-GD
49	75058-88	WIRE, fuel gauge - ground	--	--	--	93*-GD

FLT MODELS
 FLHTC DJ
 FLTC-U DM
 FLHTC-U DP
 FLHS FA
 FLHR FD

FXR MODELS
 FXR EA
 FXRS-SP EG
 FXLR EL
 FXRS-CON EM

SOFTAIL MODELS
 FLSTC BJ
 FXSTC BK
 FXSTS BL
 FLSTF BM
 FLSTN BN

DYNA MODELS
 FXDL GD
 FXDWG GE
 FXDS-CON GG

INSTRUMENTS - SOFTAIL

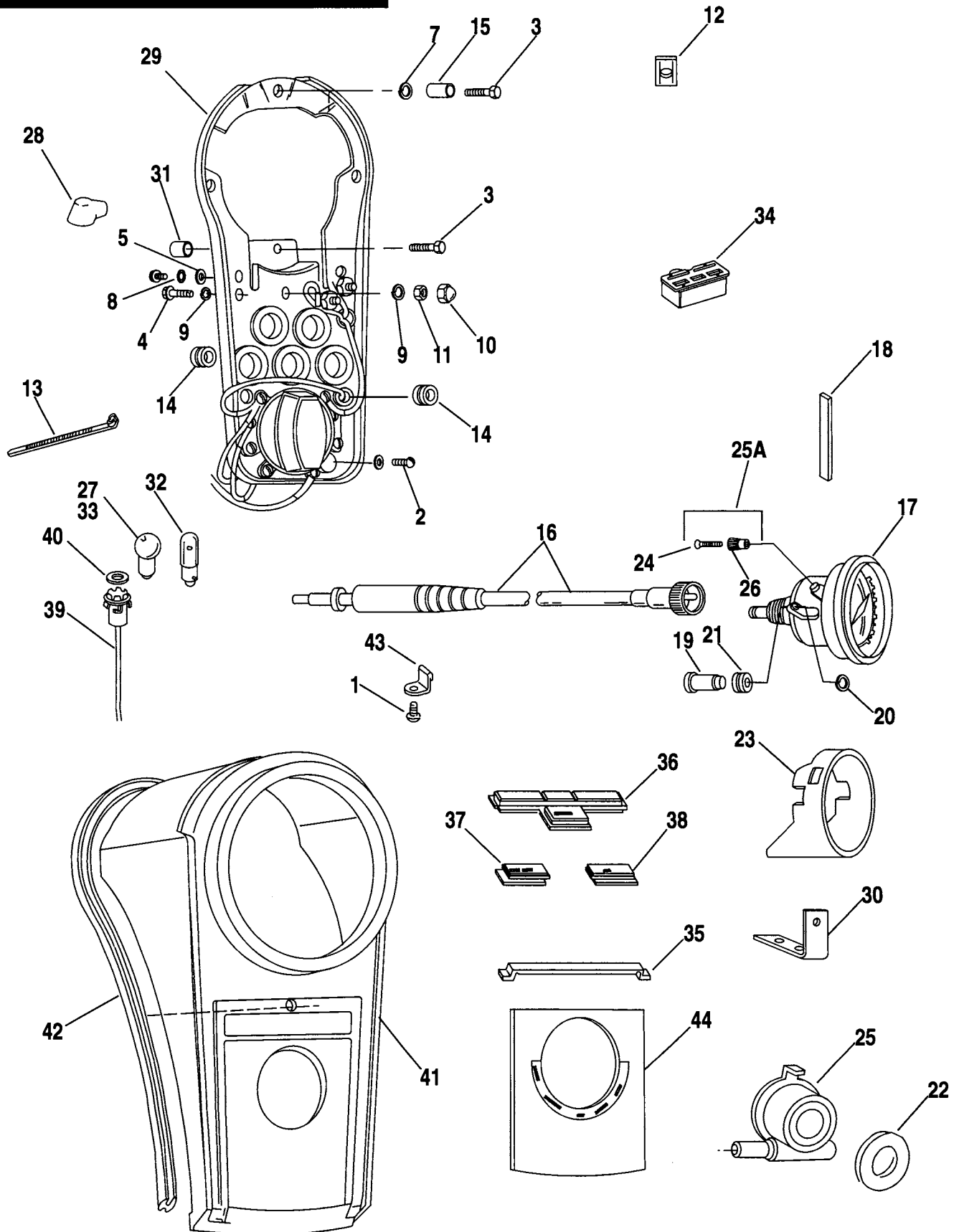

INDEX NO.	PART NO.	DESCRIPTION	FLT MODELS	FXR MODELS	SOFTAIL MODELS	DYNA MODELS
1	2567	SCREW (2)	--	--	93*-ALL	--
2	2574WA	SCREW (6)	--	--	93*-ALL	--
3	3419	BOLT (3)	--	--	93*-ALL	--
4	4739A	BOLT	--	--	93*-ALL	--
5	6198	WASHER (4)	--	--	93*-ALL	--
7	7041	LOCKWASHER	--	--	93*-ALL	--
8	7229W	LOCKWASHER (3)	--	--	93*-ALL	--
9	7232	LOCKWASHER	--	--	93*-ALL	--
10	7549	ACORN NUT	--	--	93*-ALL	--
11	7763W	NUT	--	--	93*-ALL	--
12	8155	SPEED NUT (2)	--	--	93*-ALL	--
13	10065	CABLE STRAP (6)	--	--	93*-ALL	--
14	11430	GROMMET, instrument panel (2)	--	--	93*-ALL	--
15	62043-81A	SPACER, panel mounting	--	--	93*-ALL	--
16	67024-84A	CABLE ASSEMBLY, speedometer	--	--	93*-BK/L	--
	67079-86A	CABLE ASSEMBLY, speedometer	--	--	93*-BJ/M/N	--
17	67027-91A	SPEEDOMETER - mph	--	--	93*-ALL	--
18	67067-76	ISOLATOR STRIP (black)	--	--	93*-ALL	--
19	67068-76	PIN, speedometer mounting (2)	--	--	93*-ALL	--
20	67069-76	RETAINING RING, speedometer mounting (2)	--	--	93*-ALL	--
21	67070-76	GROMMET, speedometer mounting (2)	--	--	93*-ALL	--
22	67098-87	SEAL, drive unit	--	--	93*-BL	--
	67118-87	SEAL, drive unit	--	--	93*-BJ/K/ M/N	--
23	67115-91	SUPPORT, speedometer	--	--	93*-ALL	--
24	67117-85	SCREW	--	--	93*-ALL	--
25	67120-84B	DRIVE UNIT, speedometer	--	--	93*-BK	--
	67125-86A	DRIVE UNIT, speedometer	--	--	93*-BJ/M/N	--
	67166-88	DRIVE UNIT, speedometer	--	--	93*-BL	--
25A	67212-93	RESET KNOB KIT w/ #24 & 26	--	--	93*-ALL	--
26	67215-89	KNOB, odometer reset	--	--	93*-ALL	--
27	68462-64	BULB, indicator lamps (4)	--	--	93*-ALL	--
28	70579-65	INSULATING BOOT	--	--	93*-ALL	--
29	70936-91A	INSTRUMENT PANEL BASE	--	--	93*-ALL	--
30	70939-84A	BRACKET, circuit breakers	--	--	93*-ALL	--
31	70941-84A	SPACER, instrument panel mounting (2)	--	--	93*-ALL	--
32	71090-64	BULB, speedometer (2)	--	--	93*-ALL	--
32	71092-68A	BULB, high beam	--	--	93*-ALL	--

FLT MODELS

FLHTC DJ
 FLTC-U DM
 FLHTC-U DP
 FLHS FA
 FLHR FD

FXR MODELS

FXR EA
 FXRS-SP EG
 FXLR EL
 FXRS-CON EM

SOFTAIL MODELS

FLSTC BJ
 FXSTC BK
 FXSTS BL
 FLSTF BM
 FLSTN BN

DYNA MODELS

FXDL GD
 FXDWG GE
 FXDS-CON GG

INSTRUMENTS - SOFTAIL

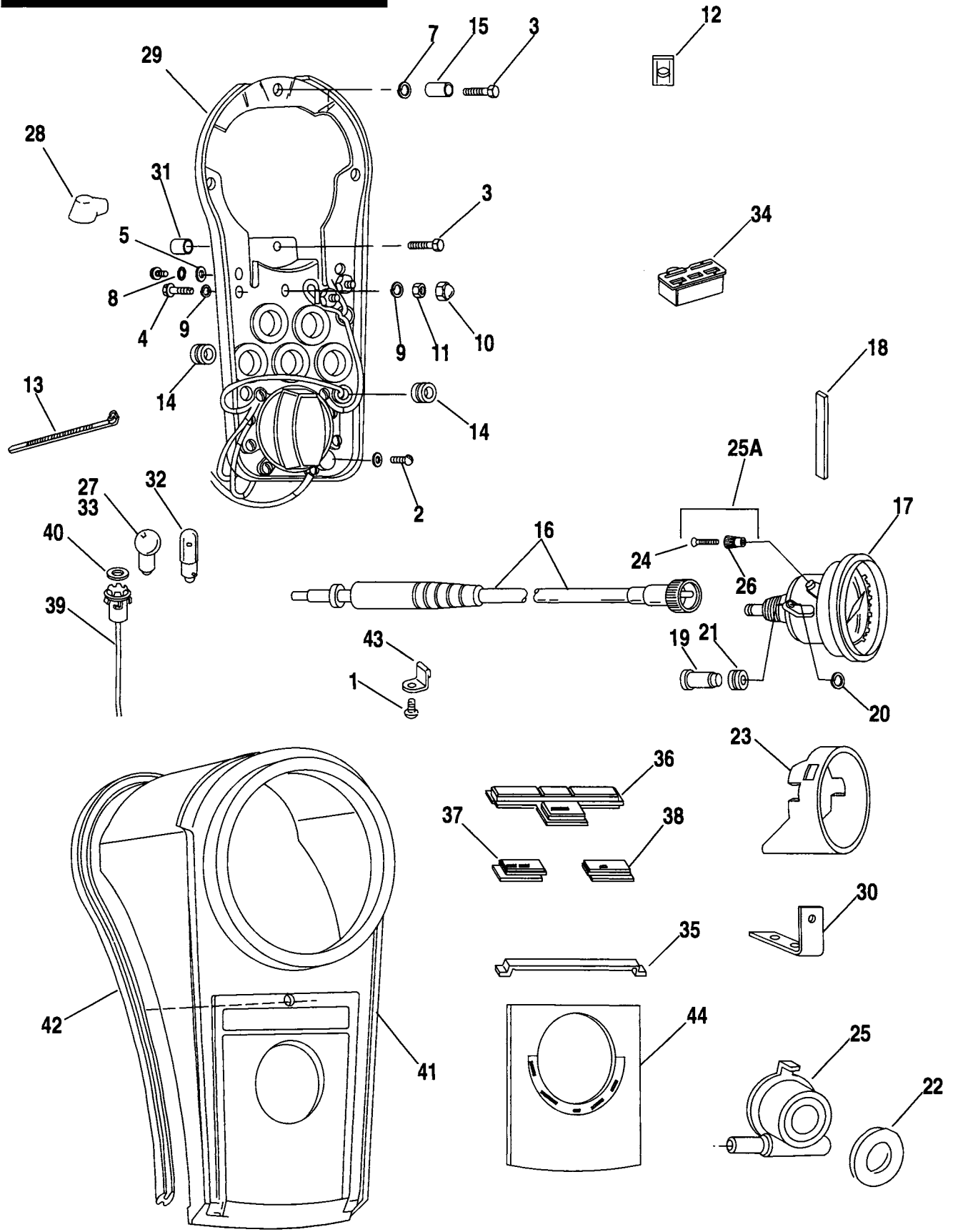

INDEX NO.	PART NO.	DESCRIPTION	FLT MODELS	FXR MODELS	SOFTAIL MODELS	DYNA MODELS
34	71134-68	SUPPORT, indicator lamp lens	--	--	93*-ALL	--
35	71141-68	RETAINER, indicator lamp lens	--	--	93*-ALL	--
36	71143-90	LENS, neutral (green)	--	--	93*-ALL	--
37	71144-75A	LENS, high beam (blue)	--	--	93*-ALL	--
38	71145-75	LENS, oil pressure (red)	--	--	93*-ALL	--
39	71158-86B	SOCKET KIT, speedometer lamp	--	--	93*-ALL	--
40	71182-47A	WASHER, signal lamp socket (4)	--	--	93*-ALL	--
41	71241-91	COVER, instrument panel (chrome)	--	--	93*-ALL	--
42	71295-68	GASKET, instrument panel cover (2)	--	--	93*-ALL	--
43	71297-68	CLIP, lens support (2)	--	--	93*-ALL	--
44	71300-79	PLATE, ignition switch	--	--	93-BJ/K/L/M	--
	71300-94	PLATE, ignition switch	--	--	94*-ALL	--

H-D INTERNATIONAL ONLY

17	67030-91A	SPEEDOMETER - kph (HDI only)	--	--	93*-ALL	--
36	71150-92	LENS, neutral (green)	--	--	93*-ALL	--
37	71151-92	LENS, high beam (blue)	--	--	93*-ALL	--
38	71152-92	LENS, oil pressure (red)	--	--	93*-ALL	--

FLT MODELS

FLHTC DJ
 FLTC-U DM
 FLHTC-U DP
 FLHS FA
 FLHR FD

FXR MODELS

FXR EA
 FXRS-SP EG
 FXLR EL
 FXRS-CON EM

SOFTAIL MODELS

FLSTC BJ
 FXSTC BK
 FXSTS BL
 FLSTF BM
 FLSTN BN

DYNA MODELS

FXDL GD
 FXDWG GE
 FXDS-CON GG

INSTRUMENTS - FXDWG

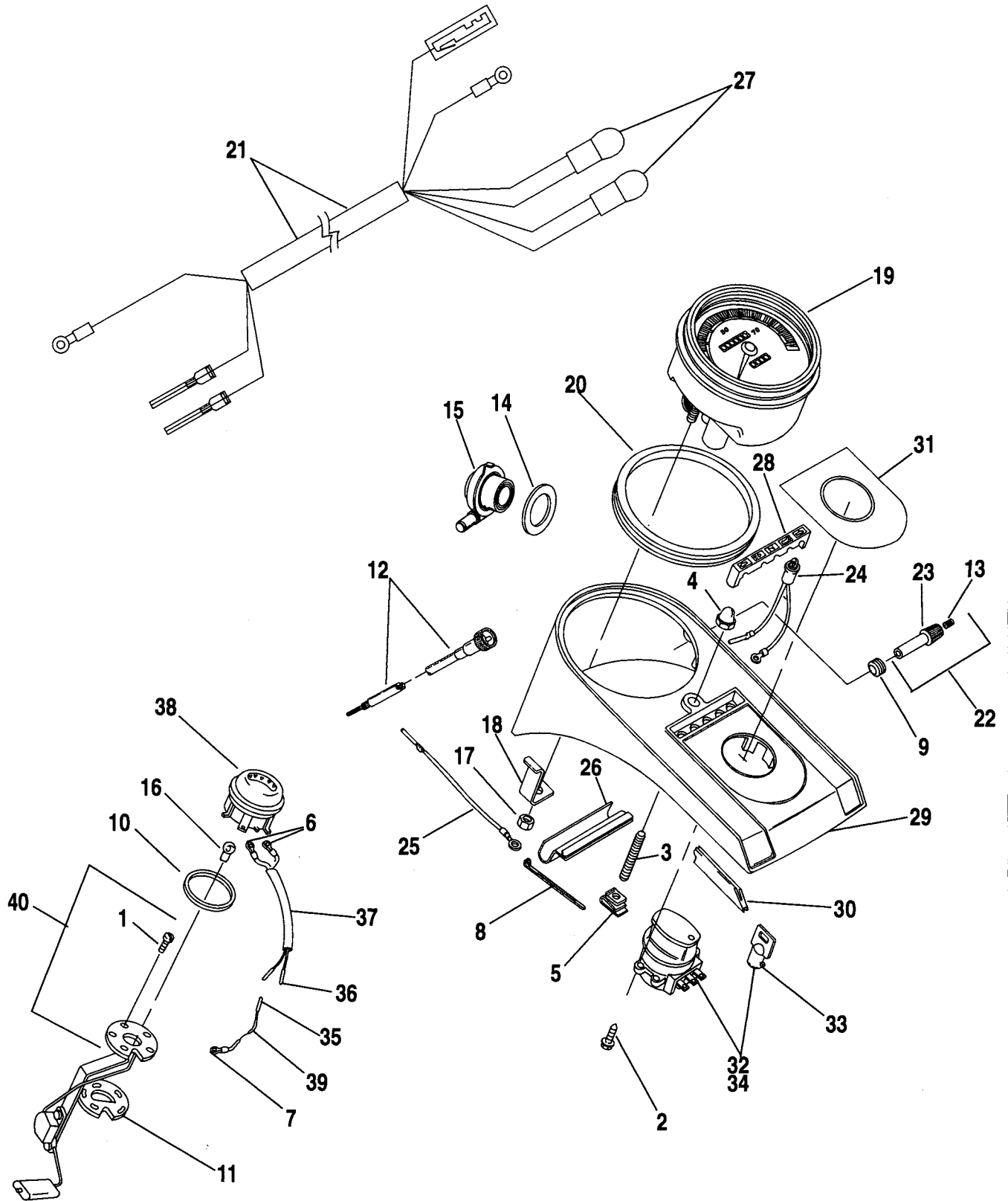

INDEX NO.	PART NO.	DESCRIPTION	FLT MODELS	FXR MODELS	SOFTAIL MODELS	DYNA MODELS
1	1311B	SCREW (5)	--	--	--	93*-GE
2	2501A	SCREW (6)	--	--	--	93*-GE
3	3250	SET SCREW	--	--	--	93*-GE
4	7549	ACORN NUT	--	--	--	93*-GE
5	8102	CAGE NUT	--	--	--	93*-GE
6	9856	TERMINAL, ring type - #6 hole (4)	--	--	--	93*-GE
7	9857	TERMINAL, ring type - #10 hole	--	--	--	93*-GE
8	10065	CABLE STRAP	--	--	--	93*-GE
9	11480	GROMMET	--	--	--	93*-GE
10	61192-88	GASKET, cap gauge	--	--	--	93*-GE
11	61324-88	GASKET, fuel sending unit	--	--	--	93*-GE
12	67024-84A	CABLE ASM. speedometer	--	--	--	93*-GE
13	67117-85	SCREW, odometer knob	--	--	--	93*-GE
14	67118-87	SEAL, speedometer drive	--	--	--	93*-GE
15	67120-84B	DRIVE UNIT, speedometer	--	--	--	93*-GE
16	67136-85	BULB, fuel gauge	--	--	--	93*-GE
17	67175-89	NUT (2)	--	--	--	93*-GE
18	67176-89	BRACKET, speedometer (2)	--	--	--	93*-GE
19	67178-93	SPEEDOMETER - mph	--	--	--	93*-GE
	67179-93	SPEEDOMETER - kph	--	--	--	93*-GE
20	67190-89	SEAL, speedometer	--	--	--	93*-GE
21	67205-89	WIRING HARNESS, speedometer	--	--	--	93*-GE
22	67212-93	RESET KNOB KIT w/ #13 & 23	--	--	--	93*-GE
23	67215-89	KNOB, odometer	--	--	--	93*-GE
24	68708-93	INDICATOR LIGHT (5)	--	--	--	93*-GE
25	70185-93	GROUND WIRE	--	--	--	93*-GE
26	70982-93	SHIELD, indicator light wiring	--	--	--	93*-GE
27	71099-74	BULB, speedometer (2)	--	--	--	93*-GE
28	71142-93	LENS, indicator lights	--	--	--	93*-GE
29	71246-92	INSTRUMENT PANEL	--	--	--	93*-GE
30	71299-93	TRIM, instrument panel	--	--	--	93*-GE
31	71302-93	NAMEPLATE, ignition switch	--	--	--	93*-GE
32	71419-93	LOCK SET, w/ fork lock & #34	--	--	--	93*-GE
33	71452-91A	KEY (specify key code number)	--	--	--	93*-GE
34	71501-93	IGNITION SWITCH w/ keys	--	--	--	93*-GE
35	72038-71	SOCKET, single pin	--	--	--	93*-GE
36	72039-71	PIN, single socket	--	--	--	93*-GE
37	75047-88	HARNESS, fuel gauge	--	--	--	93*-GE
38	75049-88A	FUEL GAUGE	--	--	--	93*-GE
39	75058-88	WIRE, fuel gauge - ground	--	--	--	93*-GE
40	75062-90	SENDING UNIT	--	--	--	93*-GE

FLT MODELS

FLHTC DJ
 FLTC-U DM
 FLHTC-U DP
 FLHS FA
 FLHR FD

FXR MODELS

FXR EA
 FXRS-SP EG
 FXLR EL
 FXRS-CON EM

SOFTAIL MODELS

FLSTC BJ
 FXSTC BK
 FXSTS BL
 FLSTF BM
 FLSTN BN

DYNA MODELS

FXDL GD
 FXDWG GE
 FXDS-CON GG

FUEL TANK INSTRUMENTS - FXDS-CON

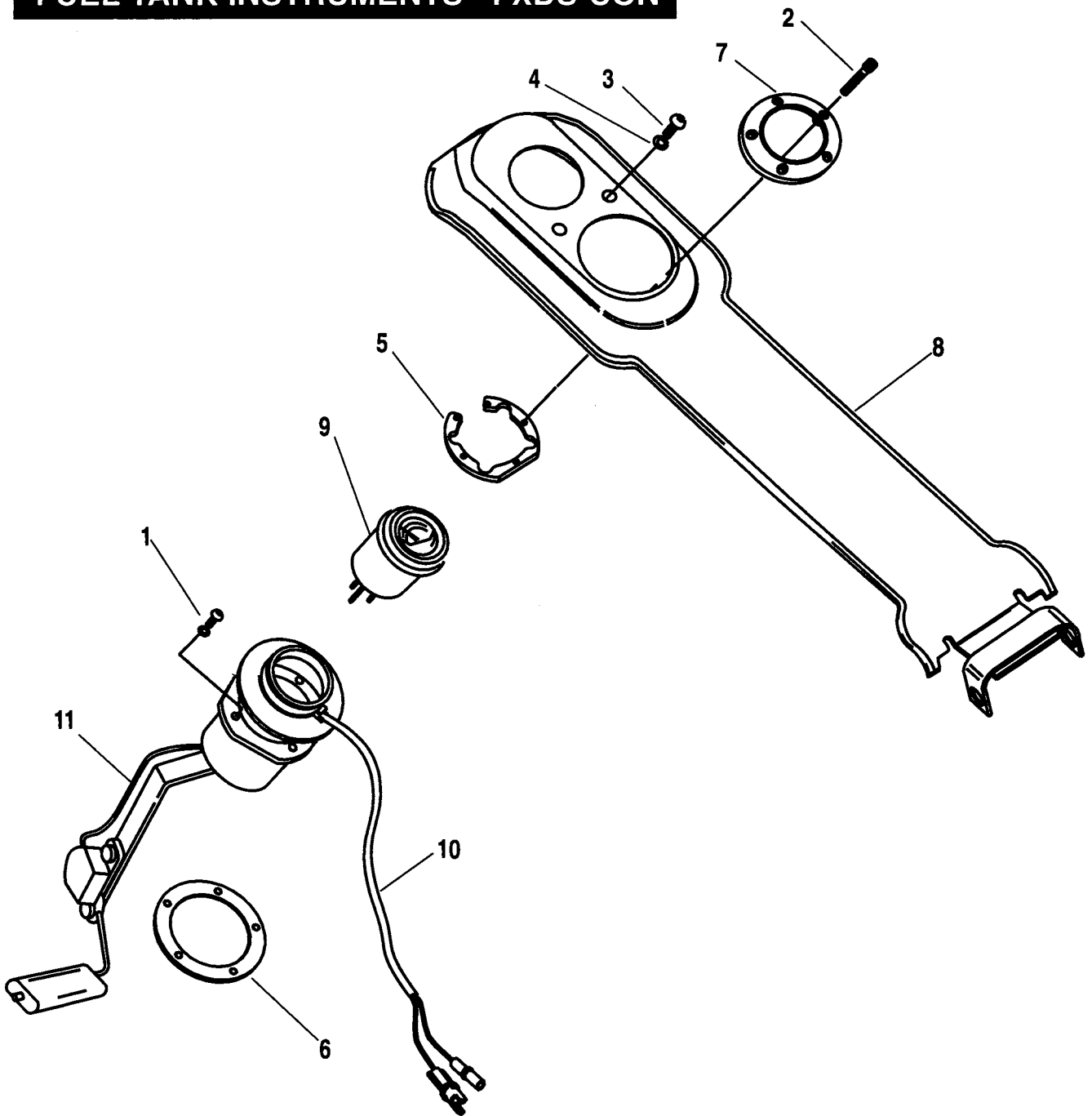

INDEX NO.	PART NO.	DESCRIPTION	FLT MODELS	FXR MODELS	SOFTAIL MODELS	DYNA MODELS
1	1311B	SCREW, sealing (5)	--	--	--	94*-GG
2	1319	SCREW (5)	--	--	--	94*-GG
3	4363	SCREW (black)(2)	--	--	--	94*-GG
4	7017	WASHER (black)(2)	--	--	--	94*-GG
5	61235-94	RING, trim panel	--	--	--	94*-GG
6	61344-94	GASKET	--	--	--	94*-GG
7	61400-94	HOUSING, fuel gauge	--	--	--	94*-GG
8	61654-94	TRIM PANEL ASM.	--	--	--	94*-GG
9	75067-94	FUEL GAUGE	--	--	--	94*-GG
10	75079-94	HARNES, fuel gauge	--	--	--	94*-GG
11	75068-94	SENDING UNIT	--	--	--	94*-GG

FLT MODELS

FLHTC DJ
 FLTC-U DM
 FLHTC-U DP
 FLMS FA
 FLHR FD

FXR MODELS

FXR EA
 FXRS-SP EG
 FXLR EL
 FXRS-CON EM

SOFTAIL MODELS

FLSTC BJ
 FXSTC BK
 FXSTS BL
 FLSTF BM
 FLSTN BN

DYNA MODELS

FXDL GD
 FXDWG GE
 FXDS-CON GG

FUEL TANK INSTRUMENTS - FLHR

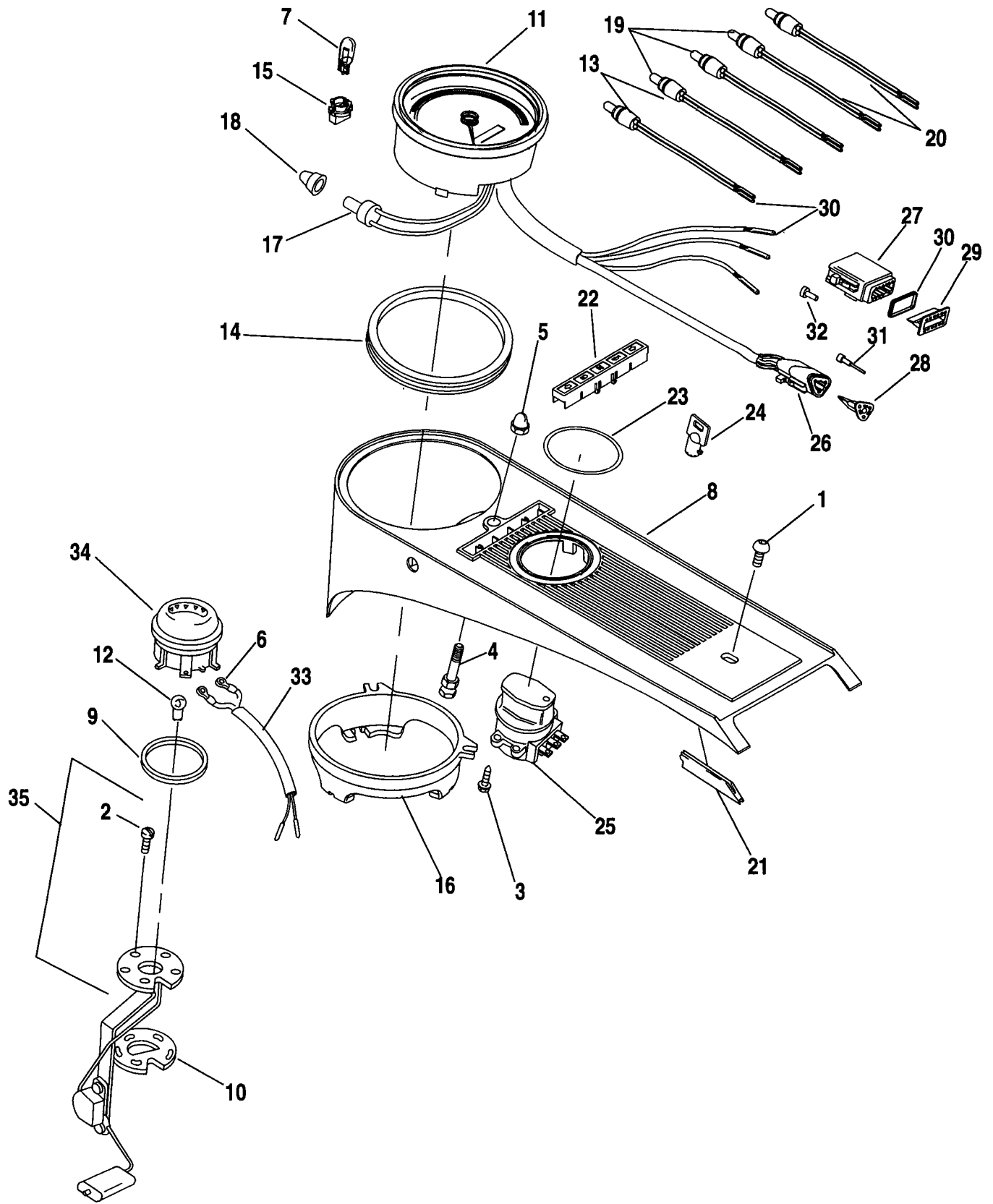

INDEX NO.	PART NO.	DESCRIPTION	FLT MODELS	FXR MODELS	SOFTAIL MODELS	DYNA MODELS
1	932	SCREW	94*-FD	--	--	--
2	1311B	SCREW, sealing (5)	94*-FD	--	--	--
3	2501A	SCREW (4)	94*-FD	--	--	--
4	3262	STUD	94*-FD	--	--	--
5	7549A	ACORN NUT	94*-FD	--	--	--
6	9856	TERMINAL, ring type #6 hole	94*-FD	--	--	--
7	52439-94	BULB, odometer	94*-FD	--	--	--
	52440-94	BULB, speedometer	94*-FD	--	--	--
	53571-94	LOCK SET, complete vehicle	94*-FD	--	--	--
8	60960-94	INSTRUMENT PANEL	94*-FD	--	--	--
9	61192-88	GASKET, fuel gauge	94*-FD	--	--	--
10	61324-88	GASKET, fuel sender	94*-FD	--	--	--
11	67033-94	SPEEDOMETER, mph	94*-FD	--	--	--
12	67136-85	BULB, fuel gauge	94*-FD	--	--	--
13	67184-94	SOCKET, indicator lamps (5)	94*-FD	--	--	--
14	67190-89	SEAL, speedometer	94*-FD	--	--	--
15	67191-94	SOCKET, speedometer (2)	94*-FD	--	--	--
16	67271-94	BACK CLAMP	94*-FD	--	--	--
17	67879-94	SWITCH, odometer reset	94*-FD	--	--	--
18	67880-94	BOOT, odometer reset switch	94*-FD	--	--	--
19	68024-94	BULB, indicator lamp	94*-FD	--	--	--
20	68799-94	WIRING HARNESS, indicator lamps (5)	94*-FD	--	--	--
21	71001-94	TRIM	94*-FD	--	--	--
22	71146-94	LENS, indicator lamps	94*-FD	--	--	--
23	71307-94	NAMEPLATE, ignition switch	94*-FD	--	--	--
24	71452-91A	KEYSET (specify 4-digit code)	94*-FD	--	--	--
25	71501-93	IGNITION SWITCH w/ key	94*-FD	--	--	--
26	72113-94BK	PLUG, 3-way socket	94*-FD	--	--	--
27	72119-94BK	PLUG, 12-way socket	94*-FD	--	--	--
28	72153-94	SOCKET LOCK, sec. 3-way	94*-FD	--	--	--
29	72159-94	SOCKET LOCK, sec. 12-way	94*-FD	--	--	--
30	72179-94	FRONT SEAL, 12-way plug	94*-FD	--	--	--
31	72191-94	TERMINAL, socket (13)	94*-FD	--	--	--
32	72195-94	SEAL PIN (2)	94*-FD	--	--	--
33	75047-88	HARNESS, fuel gauge	94*-FD	--	--	--
34	75049-88A	FUEL GAUGE	94*-FD	--	--	--
35	75062-90	SENDING UNIT	94*-FD	--	--	--
H-D INTERNATIONAL ONLY						
11	67017-94	SPEEDOMETER, kph (Japan & Canada)	94*-FD	--	--	--
	67196-94	SPEEDOMETER, mph (Great Britian)	94*-FD	--	--	--
	67197-94	SPEEDOMETER, kph (HDI only)	94*-FD	--	--	--
	67276-94	SPEEDOMETER, kph (Swiss)	94*-FD	--	--	--

FLT MODELS

FLHTC DJ
 FLTC-U DM
 FLHTC-U DP
 FLHS FA
 FLHR FD

FXR MODELS

FXR EA
 FXRS-SP EG
 FXLR EL
 FXRS-CON EM

SOFTAIL MODELS

FLSTC BJ
 FXSTC BK
 FXSTS BL
 FLSTF BM
 FLSTN BN

DYNA MODELS

FXDL GD
 FXDWG GE
 FXDS-CON GG

FRONT TURN SIGNALS - FXR, SOFTAIL & DYNA

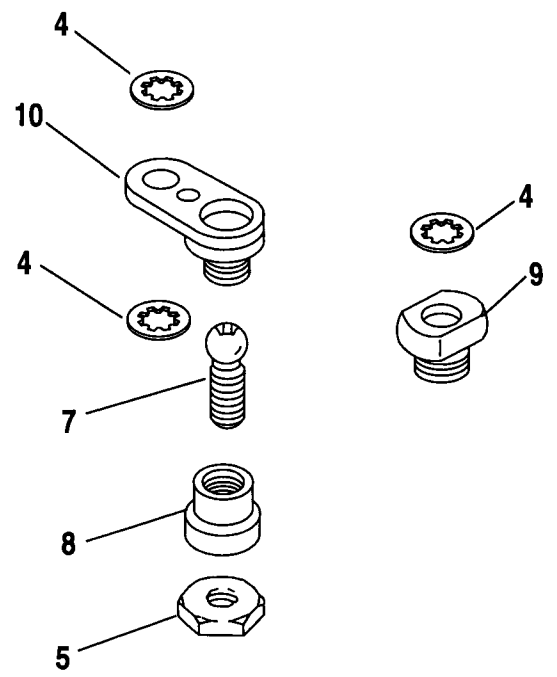
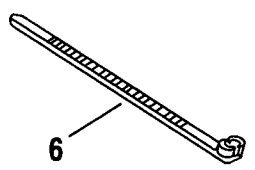
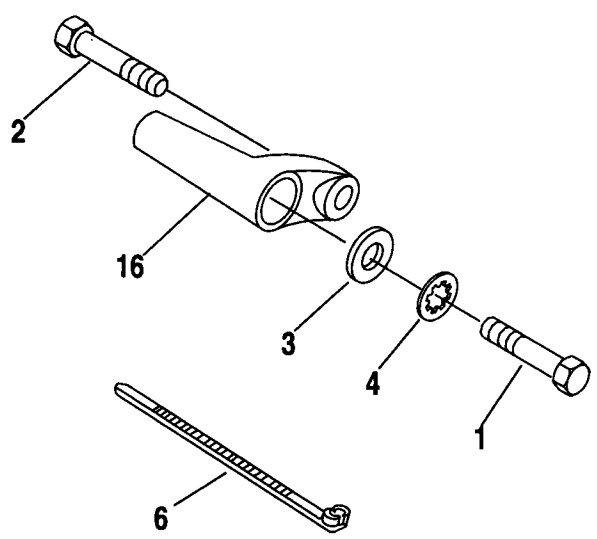
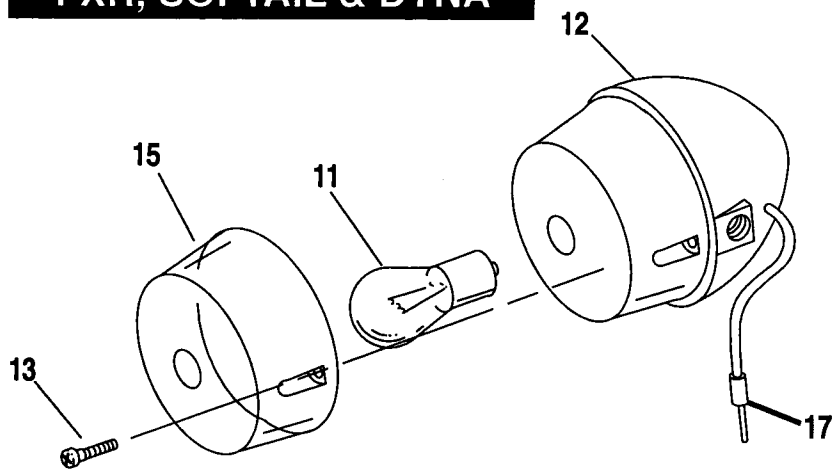

INDEX NO.	PART NO.	DESCRIPTION	FLT MODELS	FXR MODELS	SOFTAIL MODELS	DYNA MODELS
1	2698A	SCREW (2)	--	93*-EG/M	--	94*-GG
2	4047	SCREW (2)	--	93*-EG/M	--	94*-GG
3	7042	WASHER (2)	--	93*-EG/M	--	94*-GG
4	7127	LOCKWASHER (3)	--	93*-EA/L	93*-BK/L/ M/N	93*-ALL
5	7744	JAM NUT (2)	--	93*-EA/L	93*-BK/L/ M/N	93*-GD/E
6	10006	CABLE STRAP (2)	--	93*-ALL	93*-BK/L/ M/N	--
	10065	CABLE STRAP	--	--	93*-BK/L/ M/N	--
7	67822-88	BALL STUD (2)	--	93*-EA/L	93*-BK/L/ M/N	93*-GD/E
8	67827-88	CLAMP, ball stud (2)	--	93*-EA/L	93*-BK/L/ M/N	93*-GD/E
9	67828-88	RETAINER, right	--	93*-EA/L	93*-BK/L/ M/N	93*-GD/E
10	67829-88	BALL RECEPTACLE, left	--	93*-EA/L	93*-BK/L/ M/N	93*-GD/E
11	68168-89	BULB, front turn signals (2)	--	93*-ALL	93*-BK/L/ M/N	93*-ALL
12	68406-86C	LAMP w/ wire, front (2)	--	93*-ALL	93*-BK/L/ M/N	93*-ALL
13	68452-86	SCREW, turn signal lens (4)	--	93*-ALL	93*-BK/L/ M/N	93*-ALL
15	68457-86	LENS, turn signal (amber) (2)	--	93*-ALL	--	--
16	68555-87	SUPPORT, front turn signal (2)	--	93*-EG/M	--	94*-GG
17	72039-71	PIN, single socket (2)	--	93*-ALL	93*-BK/L/ M/N	--
H-D INTERNATIONAL ONLY						
11	68163-84	BULB (2) (HDI only)	--	93*-ALL	93*-BK/L/ M/N	93*-ALL
12	68408-86D	LAMP w/ wire, front (HDI only)	--	93*-ALL	93*-BK/L/ M/N	93*-ALL
15	68566-90	LENS, turn signal (amber) (2) (HDI only)	--	93*-ALL	93*-BK/L/ M/N	93*-ALL

FLT MODELS
 FLHTC
 FLTC-U
 FLHTC-U
 FLHS
 FLHR

FXR MODELS
 DJ
 DM
 DP
 FA
 FD
 FXR
 FXRS-SP
 FXLR
 FXRS-CON
 EA
 EG
 EL
 EM

SOFTAIL MODELS
 FLSTC
 FXSTC
 FXSTS
 FLSTF
 FLSTN
 BJ
 BK
 BL
 BM
 BN

DYNA MODELS
 FXDL
 FXDWG
 FXDS-CON
 GD
 GE
 GG

TAIL LAMP & REAR TURN SIGNALS

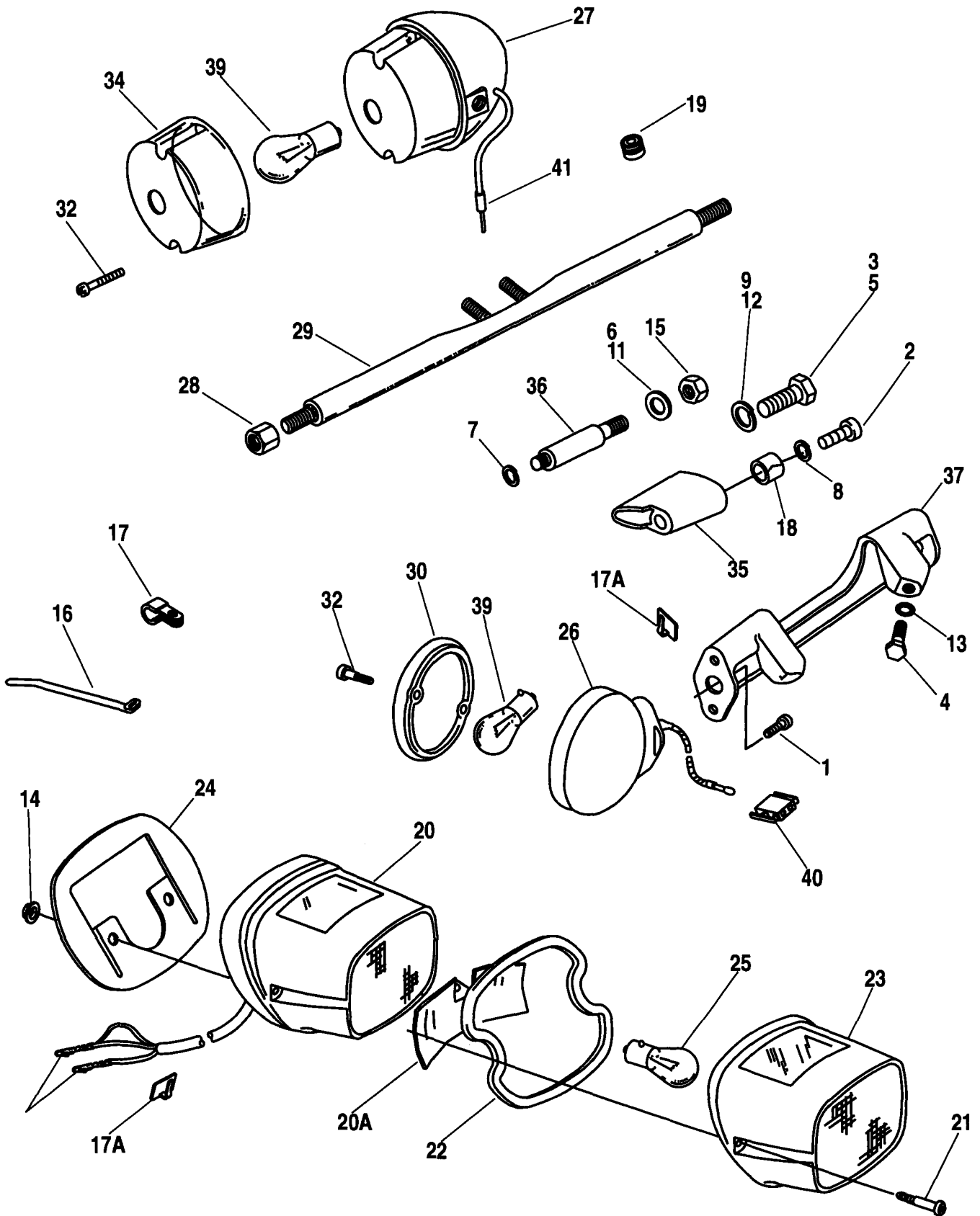

TAIL LAMP & REAR TURN SIGNALS

FB45A-1

INDEX NO.	PART NO.	DESCRIPTION	FLT MODELS	FXR MODELS	SOFTAIL MODELS	DYNA MODELS
1	2692WB	SCREW (4)	93-ALL; 94*-DJ/M/P	--	93*-BJ/N	--
2	2698A	SCREW (2)	--	--	93*-BK/L	--
	3257	SCREW (2)	--	--	--	93*-GE
	3409	SCREW (2)	--	--	--	93*-GD
3	2904A	BOLT (2)	--	--	93*-ALL	--
4	3576	BOLT (2)	93*-ALL	--	93*-BJ/N	--
5	4412	BOLT (2)	--	93*-EA/G/L	--	--
6	6701	WASHER (2)	--	93*-EA/G/L	--	93*-ALL
7	7041	LOCKWASHER (2)	--	--	--	93*-ALL
8	7042	LOCKWASHER (2)	--	--	93*-BK/L	--
	7100	LOCKWASHER (2)	--	--	--	93*-GD/E
9	7045	LOCKWASHER (2)	--	--	93*-ALL	--
11	7101	LOCKWASHER (2)	--	--	93*-BM	--
12	7130W	LOCKWASHER (2)	--	93*-EA/G/L	--	--
13	7230	LOCKWASHER	93*-ALL	--	--	--
14	7501	SPEED NUT (2)	93*-ALL	93*-ALL	93*-ALL	93*-ALL
15	7628	NUT, flange (2)	--	93*-EA/G/L	--	--
	7800W	NUT (2)	--	--	93*-BM	--
16	10065	CABLE STRAP	93*-ALL	--	93*-ALL	93*-ALL
17	10033	CLIP	93-ALL	--	93*-BJ/M/N	--
17A	10120	CLIP (2;3-FD)	94*-ALL	--	--	--
18	59959-86	SPACER	--	--	93*-ALL	--
19	67070-76	GROMMET, rear fender	--	93*-EM	--	--
20	68008-73B	TAIL LAMP ASSEMBLY	93-ALL	93*-ALL	93*-ALL	93*-GD/G
	68048-93A	TAIL LAMP ASSEMBLY	94*-ALL	--	--	93*-GE
21	68026-73	SCREW, tail lamp (2)	93*-ALL	93*-ALL	93*-ALL	93*-ALL
22	68027-90	GASKET, tail lamp lens	93*-ALL	93*-ALL	93*-ALL	93*-ALL
23	68033-90	LENS, tail lamp (red)	93*-ALL	93*-ALL	93*-ALL	93*-ALL
24	68123-73	GASKET, tail lamp housing	93*-ALL	93*-ALL	--	93*-GD/G
25	68168-89	BULB, tail lamp	93*-ALL	93*-ALL	93*-ALL	93*-ALL
26	68402-86	LAMP w/ wire, rear (amber) (2)	93-ALL	--	93*-BJ/N	--
	68713-94	LAMP w/ wire, rear (amber) (2)	94*-ALL	--	--	--
27	68407-86	LAMP w/ wire, rear (amber) (2)	--	--	93*-BK/L	93*-GD/E
	68410-87B	LAMP w/ wire, rear (amber) (2)	--	93*-ALL	93*-BM	94*-GG

FLT MODELS

FLHTC
FLTC-U
FLHTC-U
FLHS
FLHR

DJ
DM
DP
FA
FD

FXR MODELS

FXR
FXRS-SP
FXLR
FXRS-CON
EA
EG
EL
EM

SOFTAIL MODELS

FLSTC
FXSTC
FXSTS
FLSTF
FLSTN
BJ
BK
BL
BM
BN

DYNA MODELS

FXDL
FXDWG
FXDS-CON
GD
GE
GG

TAIL LAMP & REAR TURN SIGNALS

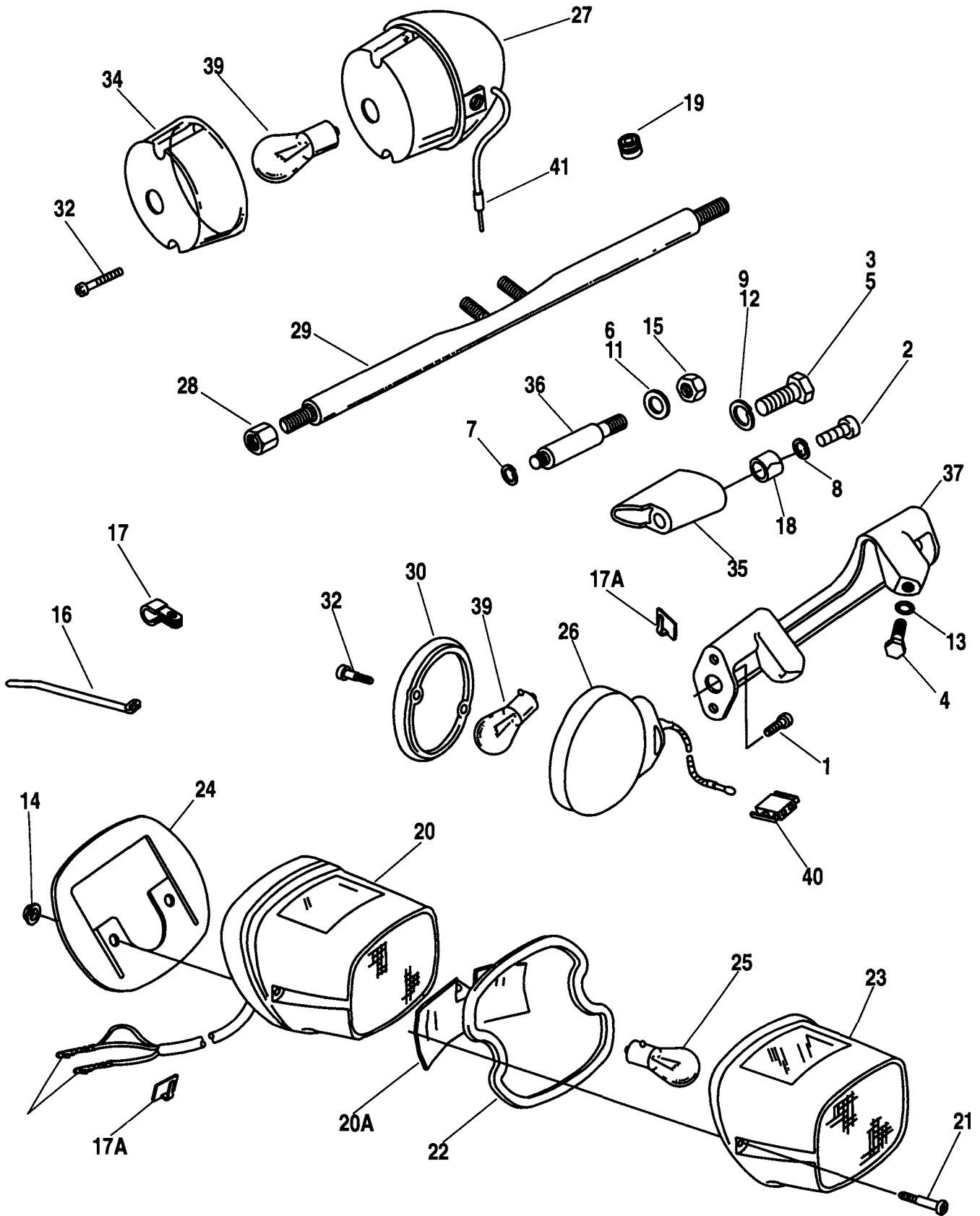

INDEX NO.	PART NO.	DESCRIPTION	FLT MODELS	FXR MODELS	SOFTAIL MODELS	DYNA MODELS
28	68424-89	NUT (2)	--	93*-EM	--	94*-GG
29	68430-89	TURN SIGNAL BAR	--	93*-EM	--	94*-GG
30	68440-86	LENS, turn signal (2)	93*-ALL	--	93*-BJ/N	--
32	68452-86	SCREW (4)	93*-ALL	93*-ALL	93*-ALL	93*-ALL
34	68457-86	LENS, turn signal	--	93*-ALL	93*-BK/L/M	93*-ALL
35	68480-73	SUPPORT, rear lamp mounting (2)	--	--	93*-BK/L	--
	68480-93	SUPPORT, rear lamp mounting (2)	--	--	--	93*-GD/E
36	68493-90	SUPPORT, rear lamp mounting	--	--	93*-BM	--
	68493-92	STUD, rear turn signal (2)	--	93*-EA/G/L	--	--
37	68510-74B	BRACKET, rear turn signal	93*-ALL	--	93*-BJ/N	--
39	68572-64B	BULB, rear turn signal (2)	93*-ALL	93*-ALL	93*-ALL	93*-ALL
40	72034-71	CONNECTOR, two pin (2)	94*-ALL	--	--	--
41	72039-71	PIN, single socket (2; 3 - GE)	93*-ALL	93*-ALL	93*-ALL	93*-ALL
H-D INTERNATIONAL ONLY						
	59710-84	COVER, rear turn signal hole (2) (HDI only)	--	--	93*-BK/L	--
20	68010-90	TAIL LAMP ASSEMBLY (HDI only)	93-ALL	93*-ALL	93*-ALL	93*-GD/G
	68049-93A	TAIL LAMP ASSEMBLY (HDI only)	94*-ALL	--	--	93*-GE
20A	68036-91	REFLECTOR, tail lamp (HDI only)	93*-ALL	93*-ALL	93*-ALL	93*-ALL
23	68032-90	LENS, tail lamp (red) (HDI only)	93*-ALL	93*-ALL	93*-ALL	93*-ALL
25	68169-90	BULB, tail lamp (HDI only)	93*-ALL	93*-ALL	93*-ALL	93*-ALL
26	68392-91A	LAMP w/ wire, rear (amber) (2) (HDI only)	93-ALL	--	93*-BJ/N	--
	68765-94	LAMP w/ wire, rear (amber) (2) (HDI only)	94*-ALL	--	--	--
27	68403-86A	LAMP w/ wire, rear (amber) (2) (HDI only)	--	93*-ALL	93*-BK/L/M	--
	68745-93	LAMP w/ wire, rear (amber) (2) (HDI only)	--	--	--	93*-ALL
30	68506-92	LENS, turn signal (amber) (2) (HDI only)	93*-ALL	--	93*-BJ/N	--
34	68507-90	LENS, turn signal (amber) (2) (HDI only)	--	93*-ALL	93*-BK/L/M	93*-ALL
39	68163-84	BULB, rear turn signal (HDI only)	93*-ALL	93*-ALL	93*-ALL	93*-ALL

FLT MODELS

FLHTC DJ
 FLTC-U DM
 FLHTC-U DP
 FLHS FA
 FLHR FD

FXR MODELS

FXR EA
 FXRS-SP EG
 FXLR EL
 FXRS-CON EM

SOFTAIL MODELS

FLSTC BJ
 FXSTC BK
 FXSTS BL
 FLSTF BM
 FLSTN BN

DYNA MODELS

FXDL GD
 FXDWG GE
 FXDS-CON GG

HORN

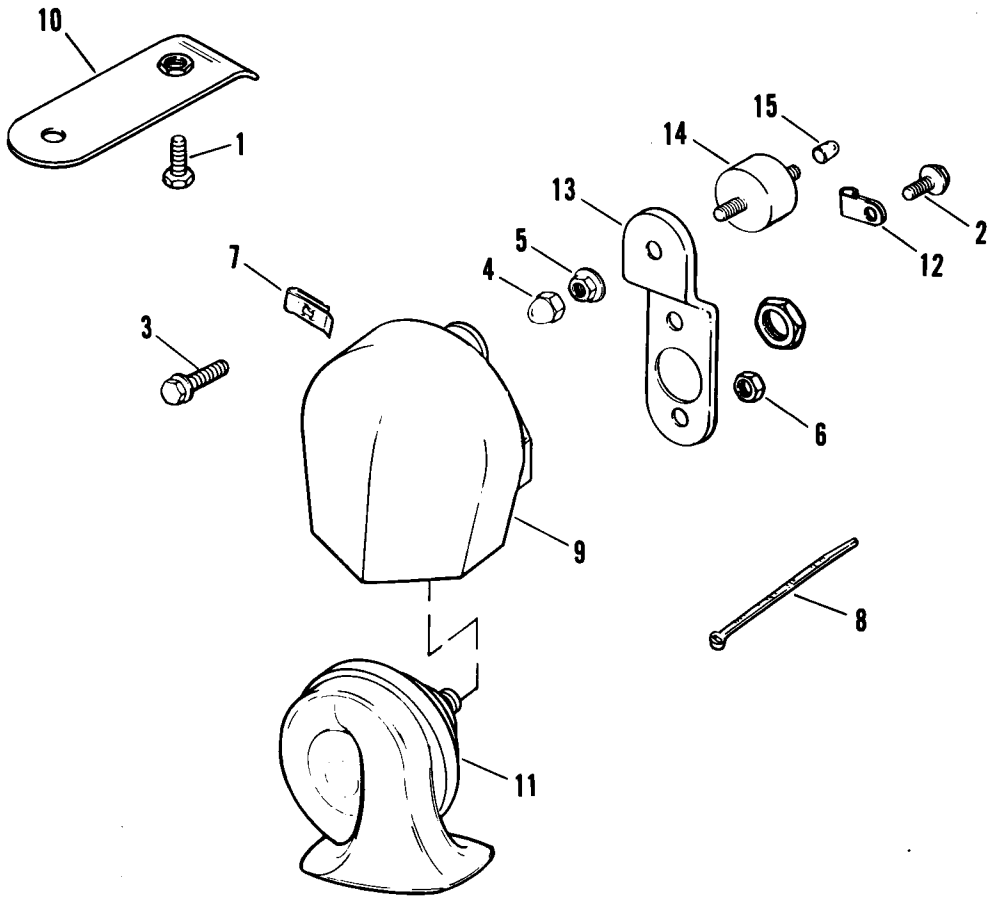

INDEX NO.	PART NO.	DESCRIPTION	FLT MODELS	FXR MODELS	SOFTAIL MODELS	DYNA MODELS
1	3576	SCREW, flangelock	--	93*-ALL	--	--
2	3588	SCREW (2)	93*-ALL	--	93*-ALL	--
3	3767B	SCREW (3)	--	--	--	93*-ALL
4	7507	ACORN NUT	93*-ALL	--	93*-ALL	--
5	7576	NUT, flange	93*-ALL	--	93*-ALL	--
6	7686	NUT (3)	--	--	--	93*-ALL
7	8108	NUT, push (2)	93*-ALL	--	93*-ALL	--
8	10006	CABLE STRAP	--	--	93*-ALL	--
9	69012-93	COVER, horn (chrome)	93*-ALL	--	93*-ALL	--
	69114-90	COVER, horn (black)	--	--	--	93*-ALL
10	69032-93	BRACKET, horn mounting	--	93*-ALL	--	--
11	69060-90A	HORN ASM.	93*-ALL	93*-ALL	93*-ALL	93*-ALL
12	69062-91	CLAMP	93*-ALL	--	93*-ALL	--
13	69120-91	BRACKET, horn	93*-ALL	--	93*-ALL	--
14	69125-65	MOUNT, horn (rubber)	93*-ALL	--	93*-ALL	--
15	89579-91	CAP, protective	93*-ALL	--	93*-ALL	--

FLT MODELS

FLHTC DJ
 FLTC-U DM
 FLHTC-U DP
 FLHS FA
 FLHR FD

FXR MODELS

FXR EA
 FXRS-SP EG
 FXLR EL
 FXRS-CON EM

SOFTAIL MODELS

FLSTC BJ
 FXSTC BK
 FXSTS BL
 FLSTF BM
 FLSTN BN

DYNA MODELS

FXDL GD
 FXDWG GE
 FXDS-CON GG

WIRING

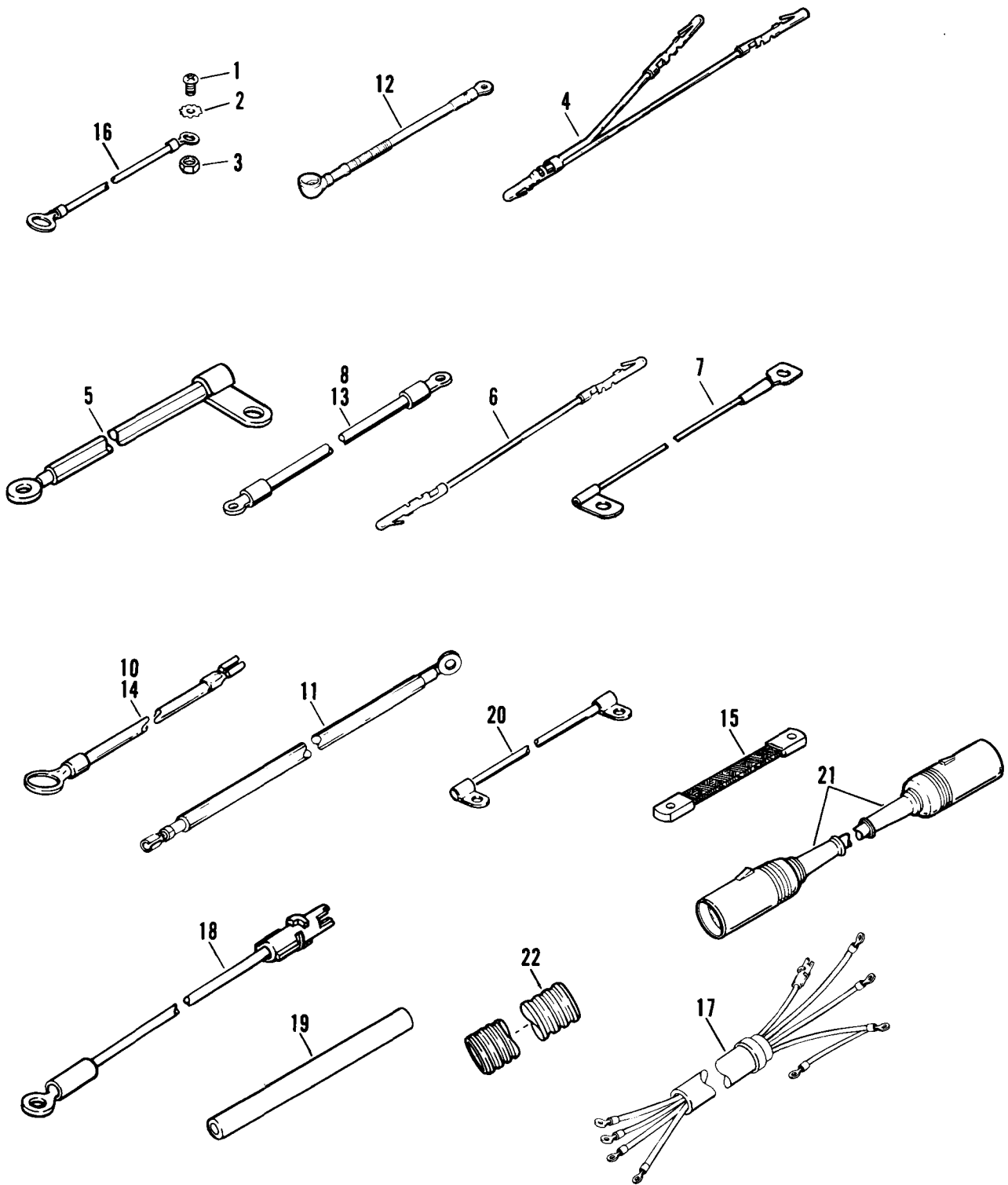

INDEX NO.	PART NO.	DESCRIPTION	FLT MODELS	FXR MODELS	SOFTAIL MODELS	DYNA MODELS
1	2582	SCREW, headlamp ground	--	--	93*-ALL	--
	4091	SCREW, handlebar ground (2)	93*-ALL	93-ALL	93-ALL	93-ALL
2	7129	LOCKWASHER	--	93*-EA/G/M	--	--
	7220	LOCKWASHER (2-FXR, SOFTAIL & DYNA)	93-ALL	93*-ALL	93*-ALL	93*-ALL
	7230	LOCKWASHER, battery ground	--	--	93*-ALL	--
3	7796	LOCKNUT, battery & starter ground (2)	--	--	--	93*-ALL
4	68705-93	WIRE ASM., head lamp	--	93*-ALL	--	--
	69551-91A	MAIN WIRING HARNESS	--	93-EA/G/M	--	--
	69551-94	MAIN WIRING HARNESS	--	94*-EA	--	--
	69555-92	MAIN WIRING HARNESS	--	93-EL	--	--
	69555-94	MAIN WIRING HARNESS	--	94*-EL	--	--
	69558-92	MAIN WIRING HARNESS	--	--	--	93-GD
	69558-94	MAIN WIRING HARNESS	--	--	--	94*-GD/G
	69631-93	MAIN WIRING HARNESS	--	--	--	93-GE
	69631-94	MAIN WIRING HARNESS	--	--	--	94*-GE
5	70011-84B	CABLE ASSEMBLY, starter to ground	93*-ALL	--	--	--
6	70022-83	WIRE ASSEMBLY, left front turn signal	--	93*-EA/G/M	--	--
	70027-83	WIRE ASSEMBLY, right front turn signal	--	93*-EA/G/M	--	--
	70029-90	WIRE ASSEMBLY, AVC	93-DJ	--	--	--
	70032-90B	WIRING HARNESS, electrical panel	--	--	--	93*-ALL
	70963-92	WIRING HARNESS, air cleaner	--	--	--	93*-ALL
	70083-89	CABLE ASSEMBLY, battery negative	--	93*-ALL	--	--
8	70034-82	CABLE ASM. battery positive to C.B. (r & gn)	--	93*-ALL	--	--
	70036-93	WIRE ASSEMBLY, batt, neg. to circuit breaker	93-ALL	--	--	--
10	70050-92	WIRE ASSEMBLY, headlamp ground	--	93*-EA/G/M	--	--
11	70060-92	CABLE ASSEMBLY, batt. (FXR Mod.-Positive; Softail Mod.-Negative)	--	93*-ALL	93*-ALL	--
12	70078-91	CABLE ASSEMBLY, battery positive	--	--	93*-ALL	--
13	70102-90	CABLE ASSEMBLY, battery positive	--	--	--	93*-ALL
	70103-90	CABLE ASSEMBLY, battery negative	--	--	--	93*-ALL
	70107-90	CABLE ASSEMBLY, battery negative	--	--	--	93*-ALL
	70267-93A	CABLE ASM., battery negative to starter	93*-ALL	--	--	--
	70377-93B	CABLE ASSEMBLY, battery positive	93*-ALL	--	--	--
14	70132-89	WIRING HARNESS, lighter	93*-DM	--	--	--
	70141-93	WIRING HARNESS, cruise cont. & radio pwr.	93-DM	--	--	--
	70142-93	WIRE ASSEMBLY, handlebar ground (black)	93-ALL	--	--	--
	70158-89	WIRING HARNESS, lighter	93-DP	--	--	--
	70172-89	WIRING HARNESS, fairing	93-DM	--	--	--
	70250-93	WIRING HARNESS, ignition switch	--	--	--	93*-GE
15	70186-82	STRAP, ground	--	93*-ALL	--	--
16	70191-73A	WIRE ASSEMBLY, handlebar ground	--	93*-ALL	93*-ALL	93*-ALL
	70284-93	WIRE ASM. cruise brkr to accy. brkr.	93-ALL	--	--	--
	70216 -93A	MAIN WIRING HARNESS	--	--	93*-ALL	--
	70234-93	WIRING HARNESS, front section	93-DJ/P	--	--	--
	70245-93	MAIN WIRING HARNESS	93-FA	--	--	--
	70285-89	WIRING HARNESS, front section	93-FA	--	--	--
	70296-89	CABLE ASSEMBLY, fuse board	93*-DM	--	--	--
	70297-93	WIRE ASM., w/ fuse - parking lamp switch	93*-DM/P	--	--	--

FLT MODELS

FLHTC
FLTC-U
FLHTC-U
FLHS
FLHR

DJ
DM
DP
FA
FD

FXR MODELS

FXR
FXRS-SP
FXLR
FXRS-CON

EA
EG
EL
EM

SOFTAIL MODELS

FLSTC
FXSTC
FXSTS
FLSTF
FLSTN

BJ
BK
BL
BM
BN

DYNA MODELS

FXDL
FXDWG
FXDS-CON

GD
GE
GG

WIRING

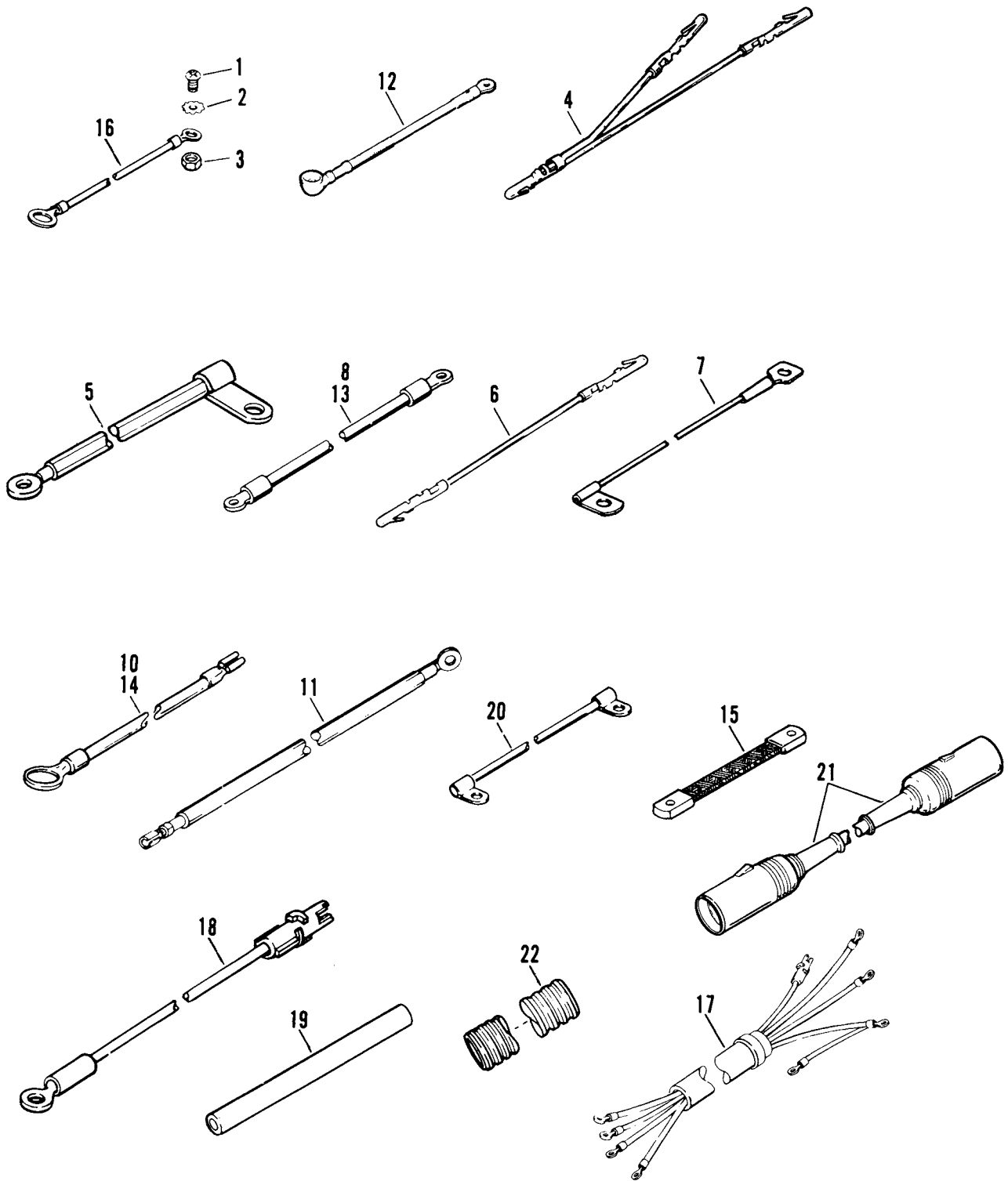

INDEX NO.	PART NO.	DESCRIPTION	FLT MODELS	FXR MODELS	SOFTAIL MODELS	DYNA MODELS	
17	70301-93	WIRING HARNESS, front section	93-DM	--	--	--	
18	70328-84	WIRE ASM. fuel sending unit (yellow/white)	93*-ALL	--	--	--	
	70344-92	WIRING HARNESS, front section	--	--	--	93-GD	
	70344-94	WIRING HARNESS, front section	--	--	--	94*-GD	
19	70551-69	CONDUIT, 1/8" I.D. - htm. (black)	--	93*-ALL	93*-ALL	--	
	70552-69	CONDUIT, 3/8" I.D. (black)	--	93*-ALL	93*-ALL	--	
	70553-69	CONDUIT, 7/16" I.D. (black)	--	93*-ALL	93*-ALL	--	
	70554-69	CONDUIT, 1/4" I.D. (black)	--	93*-ALL	93*-ALL	--	
	70555-69	CONDUIT, 1/4" I.D. - htm. (black)	--	93*-ALL	93*-ALL	--	
	70556-71	CONDUIT, 5/16" I.D. (black)	--	93*-ALL	93*-ALL	--	
	70558-71	CONDUIT, 1/2" I.D. (black)	--	93*-ALL	93*-ALL	--	
	70559-71	CONDUIT, 1/8" I.D. (black)	--	93*-ALL	93*-ALL	--	
20	70966-84	WIRE ASM., battery positive to relay (black)	93*-ALL	--	--	--	
	70985-93	MAIN WIRING HARNESS	93-DJ/M/P	--	--	--	
21	76292-92A	CABLE ASSEMBLY, console to radio	93*-DM/P	--	--	--	
		NOTE: Insulator is sold only in bulk length under the following part number. Cut to length.					
22	63505-84	INSULATOR, 1/2" I.D. (nylon) (8 ft. lg.)	93*-ALL	93*-ALL	93*-ALL	--	
		H-D INTERNATIONAL ONLY					
	69556-89	HARNESS, pass & park lamps (HDI only)	93*-DJ/P	--	--	--	
	70281-89	HARNESS, park lamps (HDI only)	93*-DB/M	--	--	--	
	70321-89	MAIN WIRING HARNESS (HDI only)	--	--	93*-BJ	--	

FLT MODELS

FLHTC DJ
 FLTC-U DM
 FLHTC-U DP
 FLHS FA
 FLHR FD

FXR MODELS

FXR EA
 FXRS-SP EG
 FXLR EL
 FXRS-CON EM

SOFTAIL MODELS

FLSTC BJ
 FXSTC BK
 FXSTS BL
 FLSTF BM
 FLSTN BN

DYNA MODELS

FXDL GD
 FXDWG GE
 FXDS-CON GG

WIRING HARNESS, MISCELLANEOUS - 1994 FLT MODELS

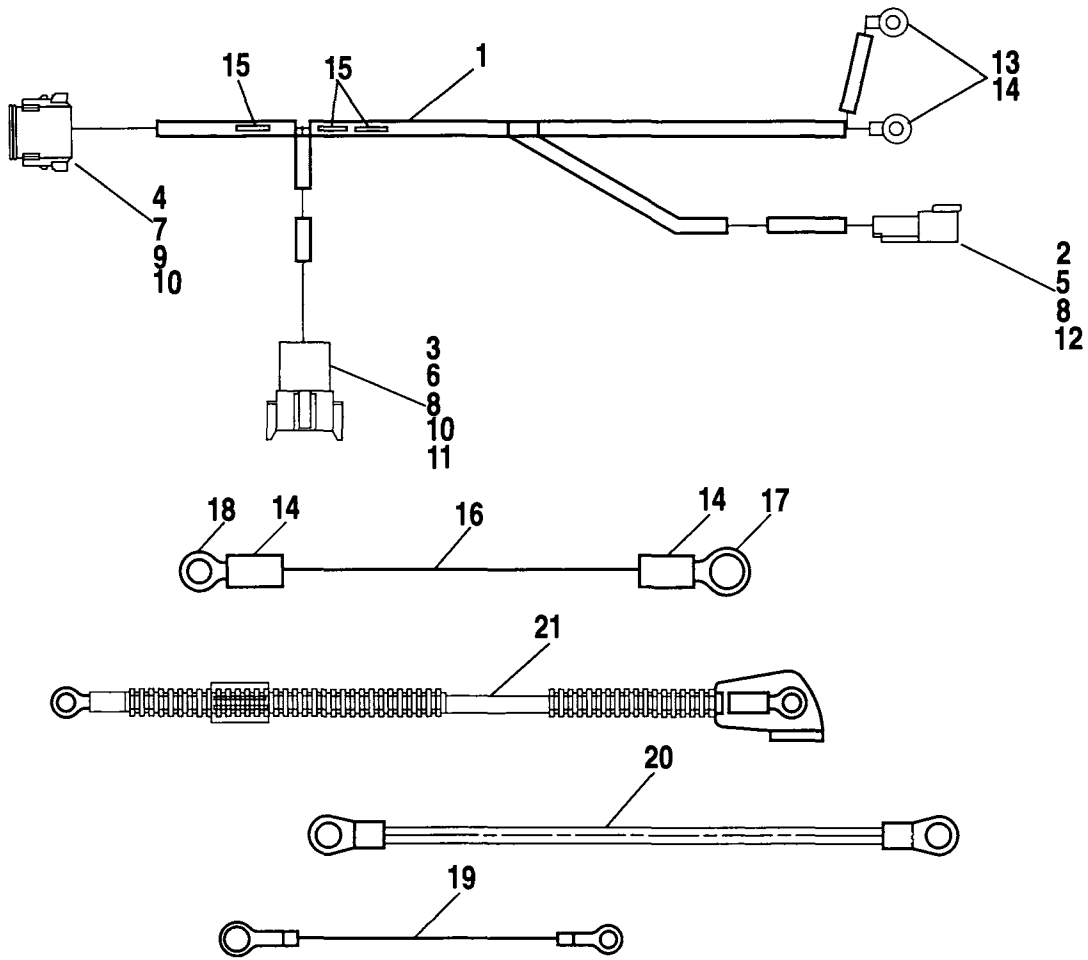

INDEX NO.	PART NO.	DESCRIPTION	FLT MODELS	FXR MODELS	SOFTAIL MODELS	DYNA MODELS
1	32435-94	IGNITION WIRING HARNESS includes the following:	94*-ALL	--	--	--
2	72102-94BK	RECEPTACLE, 2-way pin	94*-ALL	--	--	--
3	72108-94BK	RECEPTACLE, 8-way pin	94*-ALL	--	--	--
4	72138-94GY	PLUG, 8-way socket	94*-ALL	--	--	--
5	72142-94	PIN LOCK, sec., 2-way	94*-ALL	--	--	--
6	72148-94	PIN LOCK, sec., 8-way	94*-ALL	--	--	--
7	72158-94	SOCKET LOCK, sec., 8-way	94*-ALL	--	--	--
8	72190-94	TERMINAL, pin (9)	94*-ALL	--	--	--
9	72191-94	TERMINAL, socket (6)	94*-ALL	--	--	--
10	72195-94	SEAL PIN (3)	94*-ALL	--	--	--
11	72198-94	ATTACHMENT CLIP (8-way)	94*-ALL	--	--	--
12	72199-94	ATTACHMENT CLIP	94*-ALL	--	--	--
13	72241-94	TERMINAL, #10 ring type (2)	94*-ALL	--	--	--
14	72249-94	HEAT SHRINK TUBE (2)	94*-ALL	--	--	--
15	72266-94	HEAT SHRINK TUBE, dual wall (3)	94*-ALL	--	--	--
16	70045-94	WIRE ASM., 50 amp. circuit breaker to starter includes the following:	94*-ALL	--	--	--
17	9842	TERMINAL, 5/16" ring type	94*-ALL	--	--	--
18	9843	TERMINAL, #10 ring type	94*-ALL	--	--	--
14	72249-94	HEAT SHRINK TUBE (2)	94*-ALL	--	--	--
19	70142-94	WIRE ASM., handlebar ground	94*-ALL	--	--	--
20	70267-93A	CABLE ASM., batt. neg. to starter	94*-ALL	--	--	--
21	70377-93B	CABLE ASM., batt. pos	94*-ALL	--	--	--

FLT MODELS

FLHTC DJ
 FLTC-U DM
 FLHTC-U DP
 FLHS FA
 FLHR FD

FXR MODELS

FXR EA
 FXRS-SP EG
 FXLR EL
 FXRS-CON EM

SOFTAIL MODELS

FLSTC BJ
 FXSTC BK
 FXSTS BL
 FLSTF BM
 FLSTN BN

DYNA MODELS

FXDL GD
 FXDWG GE
 FXDS-CON GG

WIRING HARNESS, FAIRING - 1994 FLT MODELS

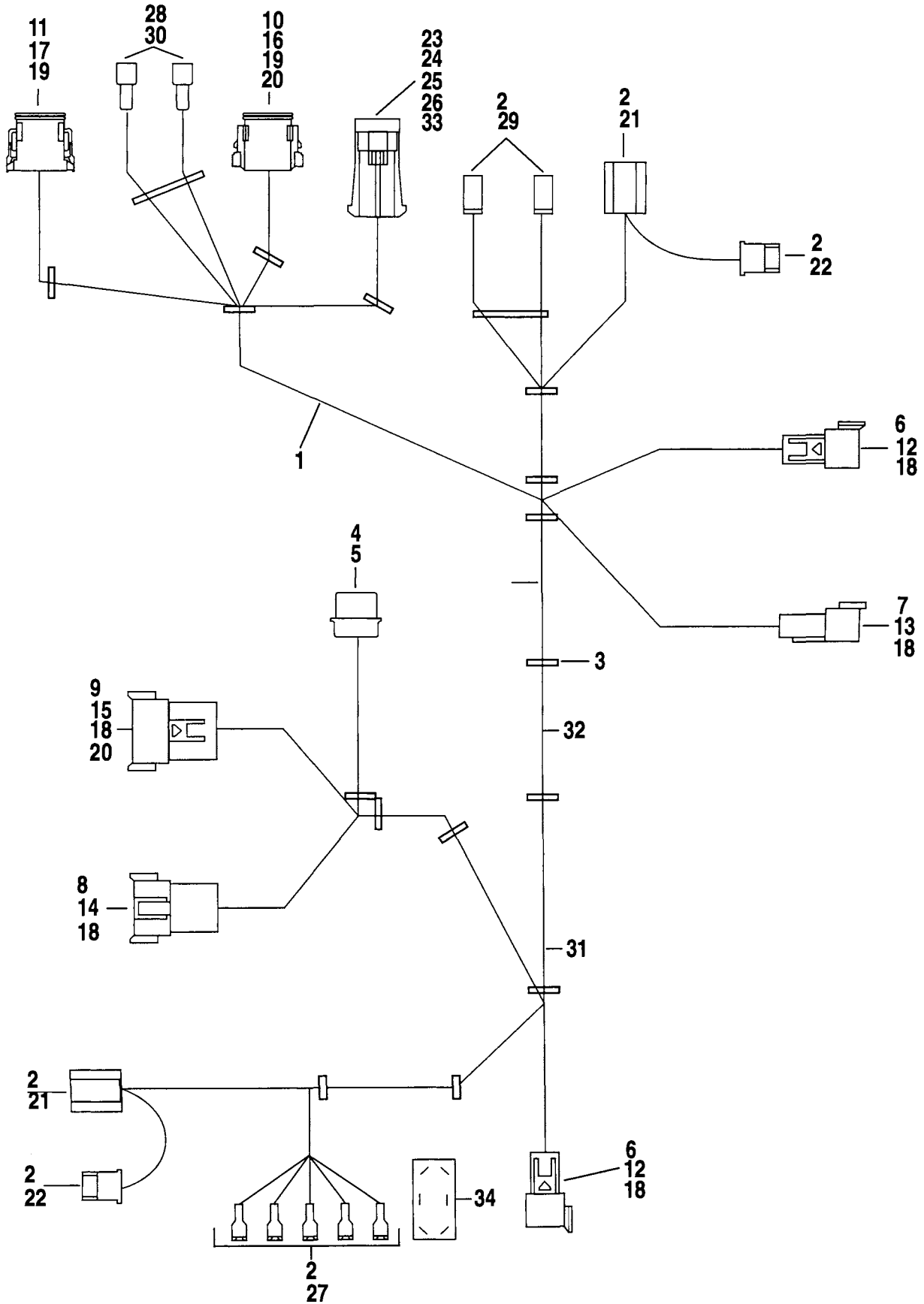

INDEX NO.	PART NO.	DESCRIPTION	FLT MODELS	FXR MODELS	SOFTAIL MODELS	DYNA MODELS
1	70172-94	FAIRING WIRING HARNESS includes the following:	94*-DM	--	--	--
2	9937	TERMINAL, 1/4" female, 14-18 ga. (16)	94*-DM	--	--	--
3	10065	CABLE STRAP (17)	94*-DM	--	--	--
4	70291-89	CONNECTOR, 4 pin	94*-DM	--	--	--
5	72039-71	PIN, single socket (4)	94*-DM	--	--	--
6	72103-94BK	RECEPTACLE, 3-way pin (2)	94*-DM	--	--	--
7	72104-94BK	RECEPTACLE, 4-way pin	94*-DM	--	--	--
8	72108-94BK	RECEPTACLE, 8-way pin	94*-DM	--	--	--
9	72109-94BK	RECEPTACLE, 12-way pin	94*-DM	--	--	--
10	72118-94BK	PLUG, 8-way socket	94*-DM	--	--	--
11	72119-94BK	PLUG, 12-way socket	94*-DM	--	--	--
12	72143-94	PIN LOCK, 3-way (2)	94*-DM	--	--	--
13	72144-94	PIN LOCK, 4-way	94*-DM	--	--	--
14	72148-94	PIN LOCK, 8-way	94*-DM	--	--	--
15	72149-94	PIN LOCK, 12-way	94*-DM	--	--	--
16	72158-94	SOCKET LOCK, sec. 8-way	94*-DM	--	--	--
17	72159-94	SOCKET LOCK, sec. 12-way	94*-DM	--	--	--
18	72190-94	TERMINAL, pin (27)	94*-DM	--	--	--
19	72191-94	TERMINAL, socket (19)	94*-DM	--	--	--
20	72195-94	SEAL PIN (4)	94*-DM	--	--	--
21	72200-94	CONNECTOR, 3-way (2)	94*-DM	--	--	--
22	72203-94	CONNECTOR, 2-way (2)	94*-DM	--	--	--
23	72233-94	CONNECTOR, receptacle, 2-way	94*-DM	--	--	--
24	72235-94	TERMINAL, male, 14-16 ga. (2)	94*-DM	--	--	--
25	72238-94	SECONDARY LOCK, 2-way	94*-DM	--	--	--
26	72239-94	CONNECTOR LOCK	94*-DM	--	--	--
27	72249-94	HEAT SHRINK TUBE, .3 X 1' (5)	94*-DM	--	--	--
28	72253-94	TERMINAL, male, 14-16 ga. (2)	94*-DM	--	--	--
29	72257-94	CONNECTOR, plug, 1-way (2)	94*-DM	--	--	--
30	72258-94	CONNECTOR, receptacle, 1-way (2)	94*-DM	--	--	--
31	72266-94	HEAT SHRINK TUBE, dual wall .3" x 2"	94*-DM	--	--	--
32	72268-94	HEAT SHRINK TUBE, dual wall .7" x 2" (3)	94*-DM	--	--	--
33	72284-94	CABLE SEAL	94*-DM	--	--	--
34	77026-92	HARNESS, speaker switch	94*-DM	--	--	--

FLT MODELS

FLHTC DJ
 FLTC-U DM
 FLHTC-U DP
 FLHS FA
 FLHR FD

FXR MODELS

FXR EA
 FXRS-SP EG
 FXLR EL
 FXRS-CON EM

SOFTAIL MODELS

FLSTC BJ
 FXSTC BK
 FXSTS BL
 FLSTF BM
 FLSTN BN

DYNA MODELS

FXDL GD
 FXDWG GE
 FXDS-CON GG

WIRING HARNESS, INTERCONNECT - 1994 FLHT

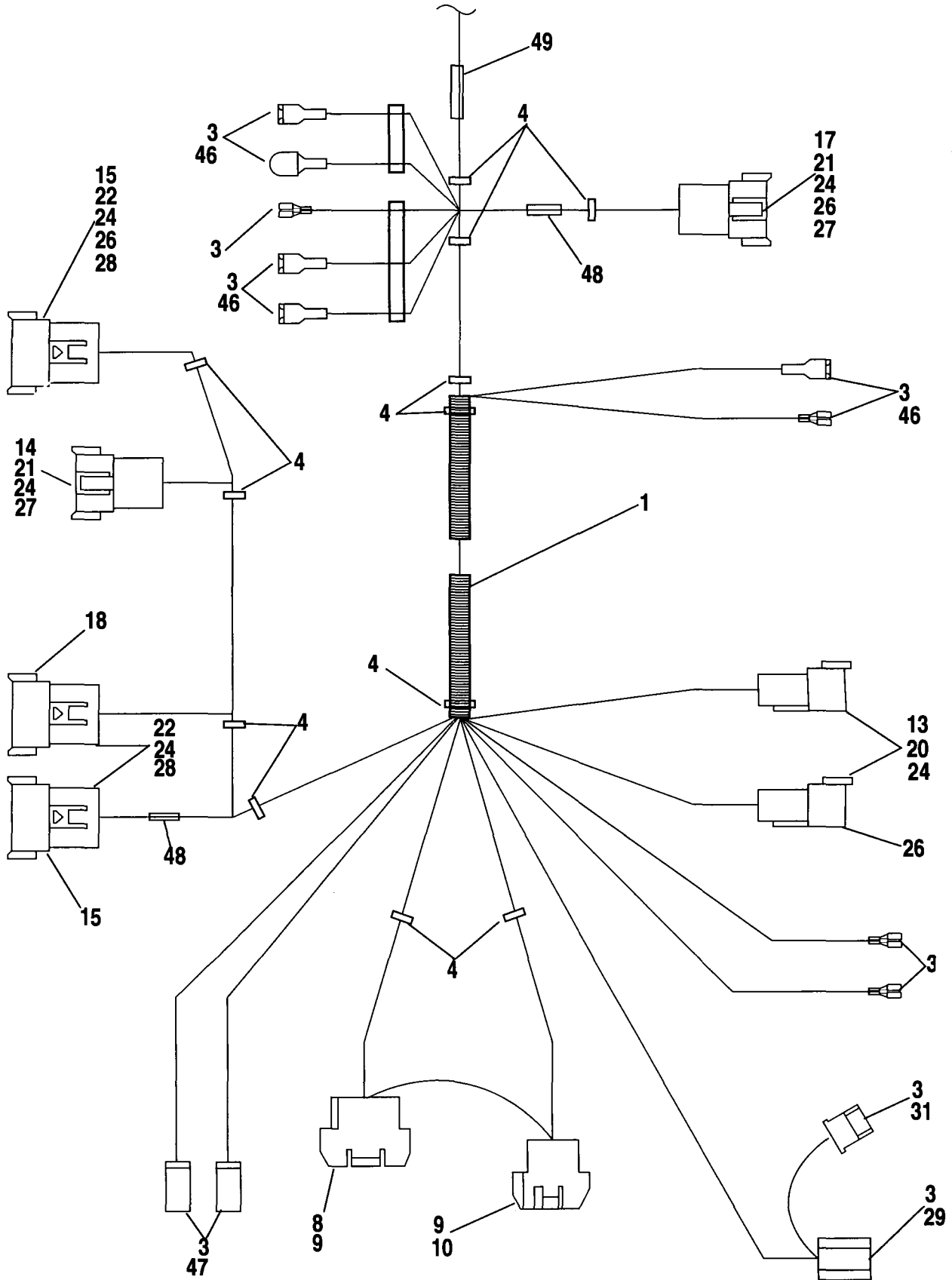

INDEX NO.	PART NO.	DESCRIPTION	FLT MODELS	FXR MODELS	SOFTAIL MODELS	DYNA MODELS
1	70232-94	WIRING HARNESS, interconnect includes the following:	94*-DJ/P	--	--	--
2	9898	TERMINAL, female flag, 14-16ga.	94*-DJ/P	--	--	--
3	9937	TERMINAL, female spade, 1/4" slot (37)	94*-DJ/P	--	--	--
4	10065	CABLE STRAP (26)	94*-DJ/P	--	--	--
5	10141	CLIP, metal connector	94*-DJ/P	--	--	--
6	31504-91A	RELAY (2)	94*-DJ/P	--	--	--
7	68634-86	HEADLAMP CONNECTION	94*-DJ/P	--	--	--
8	70288-81	CONNECTOR, eight pin	94*-DJ/P	--	--	--
9	72039-71	PIN, single socket (14)	94*-DJ/P	--	--	--
10	72041-71	CONNECTOR, 6 pin	94*-DJ/P	--	--	--
11	72046-79	INSULATOR, spade terminals (2)	94*-DJ/P	--	--	--
12	72103-94BK	RECEPTACLE, 3-way pin	94*-DJ/P	--	--	--
13	72106-94BK	RECEPTACLE, 6-way pin (2)*	94*-DJ/P	--	--	--
14	72108-94BK	RECEPTACLE, 8-way pin (2)	94*-DJ/P	--	--	--
15	72109-94BK	RECEPTACLE, 12-way pin (3)	94*-DJ/P	--	--	--
16	72112-94BK	PLUG, 2-way socket	94*-DJ/P	--	--	--
17	72128-94GY	RECEPTACLE, 8-way pin	94*-DJ/P	--	--	--
18	72129-94GY	RECEPTACLE, 12-way pin	94*-DJ/P	--	--	--
19	72143-94	PIN LOCK, sec. 3-way	94*-DJ/P	--	--	--
20	72146-94	PIN LOCK, sec. 6-way (2)	94*-DJ/P	--	--	--
21	72148-94	PIN LOCK, sec. 8-way (3)	94*-DJ/P	--	--	--
22	72149-94	PIN LOCK, sec. 12-way (4)	94*-DJ/P	--	--	--
23	72152-94	SOCKET LOCK, sec. 2-way	94*-DJ/P	--	--	--
24	72190-94	TERMINAL, pin (81)	94*-DJ/P	--	--	--
25	72191-94	TERMINAL, socket (2)	94*-DJ/P	--	--	--
26	72195-94	SEAL PIN (8)	94*-DJ/P	--	--	--
27	72198-94	ATTACHMENT CLIP (8-way only) (3)	94*-DJ/P	--	--	--
28	72199-94	ATTACHMENT CLIP (7)	94*-DJ/P	--	--	--
29	72200-94	CONNECTOR, 3-way	94*-DJ/P	--	--	--
31	72203-94	CONNECTOR, 2-way (2)	94*-DJ/P	--	--	--
32	72205-94	CONNECTOR, plug, 4-way	94*-DJ/P	--	--	--
33	72208-94	TERMINAL, male, 12 ga. (3)	94*-DJ/P	--	--	--

FLT MODELS

FLHTC DJ
 FLTC-U DM
 FLHTC-U DP
 FLHS FA
 FLHR FD

FXR MODELS

FXR EA
 FXRS-SP EG
 FXLR EL
 FXRS-CON EM

SOFTAIL MODELS

FLSTC BJ
 FXSTC BK
 FXSTS BL
 FLSTF BM
 FLSTN BN

DYNA MODELS

FXDL GD
 FXDWG GE
 FXDS-CON GG

WIRING HARNESS, INTERCONNECT - 1994 FLHT

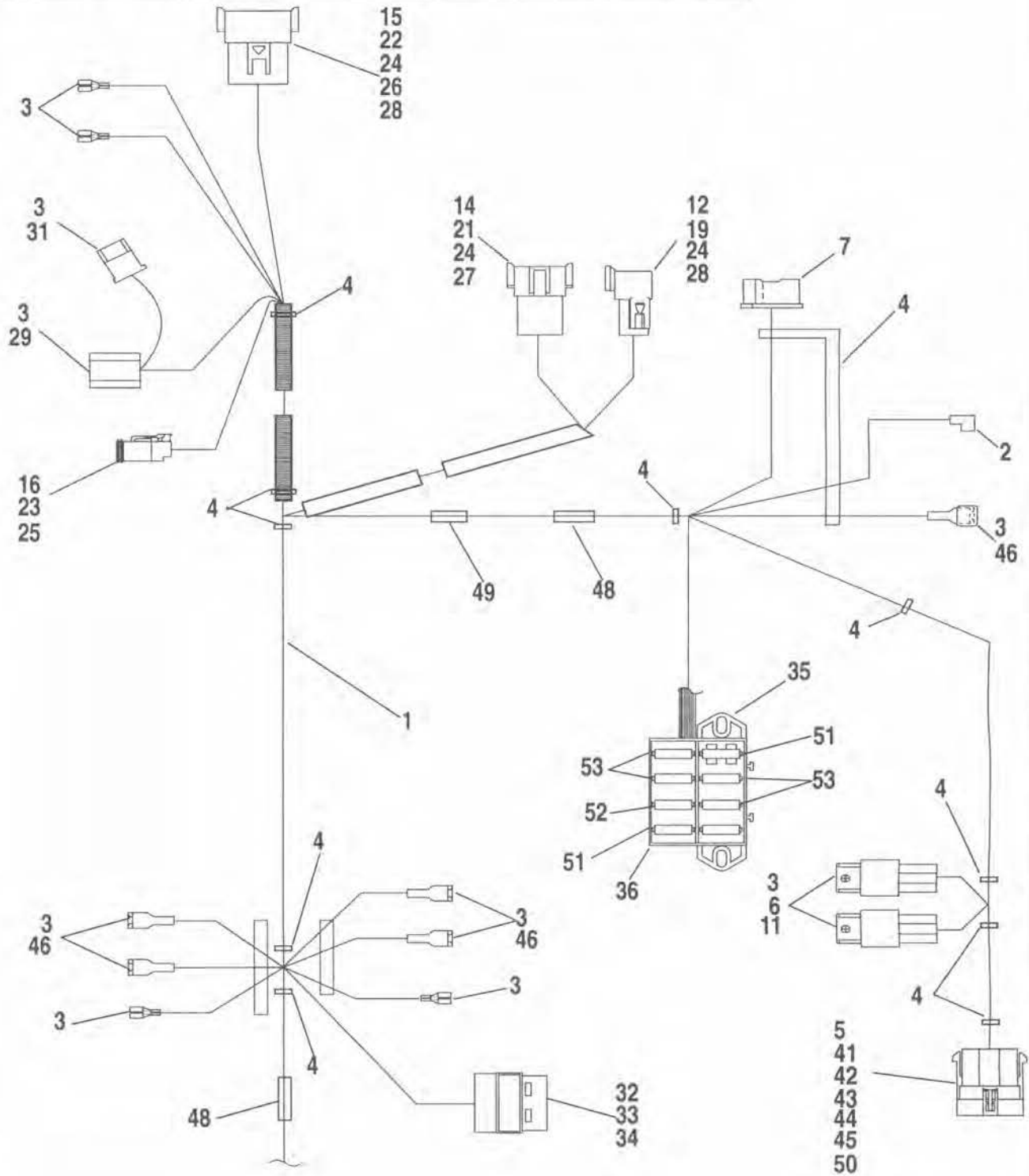

INDEX NO.	PART NO.	DESCRIPTION	FLT MODELS	FXR MODELS	SOFTAIL MODELS	DYNA MODELS
34	72209-94	TERMINAL, male, 18 ga.	94*-DJ/P	--	--	--
35	72215-94	FUSE BLOCK w/ feet	94*-DJ/P	--	--	--
36	72216-94	FUSE BLOCK	94*-DJ/P	--	--	--
37	72217-94	TERMINAL, auto fuse, 18-20 ga. (5)	94*-DJ/P	--	--	--
38	72218-94	TERMINAL, auto fuse, 14-16 ga. (7)	94*-DJ/P	--	--	--
39	72219-94	TERMINAL, auto fuse, 18 ga. (3)	94*-DJ/P	--	--	--
40	72220-94	TERMINAL, auto fuse, 14-16 ga.	94*-DJ/P	--	--	--
41	72222-94	CONNECTOR, receptacle, 3-way	94*-DJ/P	--	--	--
42	72225-94	TERMINAL, female, 14-16 ga. (2)	94*-DJ/P	--	--	--
43	72226-94	TERMINAL, male, 14-16 ga.	94*-DJ/P	--	--	--
44	72227-94	WIRE SEAL, 14 ga. (2)	94*-DJ/P	--	--	--
45	72229-94	SECONDARY LOCK, 3-way	94*-DJ/P	--	--	--
46	72249-94	HEAT SHRINK TUBE, .3 x 1" (10)	94*-DJ/P	--	--	--
47	72257-94	CONNECTOR, plug, 1-way (2)	94*-DJ/P	--	--	--
48	72266-94	HEAT SHRINK TUBE, dual wall .3" x 2" (16)	94*-DJ/P	--	--	--
49	72268-94	HEAT SHRINK TUBE, dual wall .7" x 2" (15)	94*-DJ/P	--	--	--
50	72283-94	SEAL, cable	94*-DJ/P	--	--	--
51	72300-89	FUSE, 1 amp (2)	94*-DJ/P	--	--	--
52	72340-94	FUSE, 10 amp	94*-DJ/P	--	--	--
53	74587-94	CIRCUIT BREAKER, 15 amp (4)	94*-DJ/P	--	--	--

FLT MODELS

FLHTC DJ
 FLTC-U DM
 FLHTC-U DP
 FLHS FA
 FLHR FD

FXR MODELS

FXR EA
 FXRS-SP EG
 FXLR EL
 FXRS-CON EM

SOFTAIL MODELS

FLSTC BJ
 FXSTC BK
 FXSTS BL
 FLSTF BM
 FLSTN BN

DYNA MODELS

FXDL GD
 FXDWG GE
 FXDS-CON GG

WIRING HARNESS, INTERCONNECT - 1994 FLT

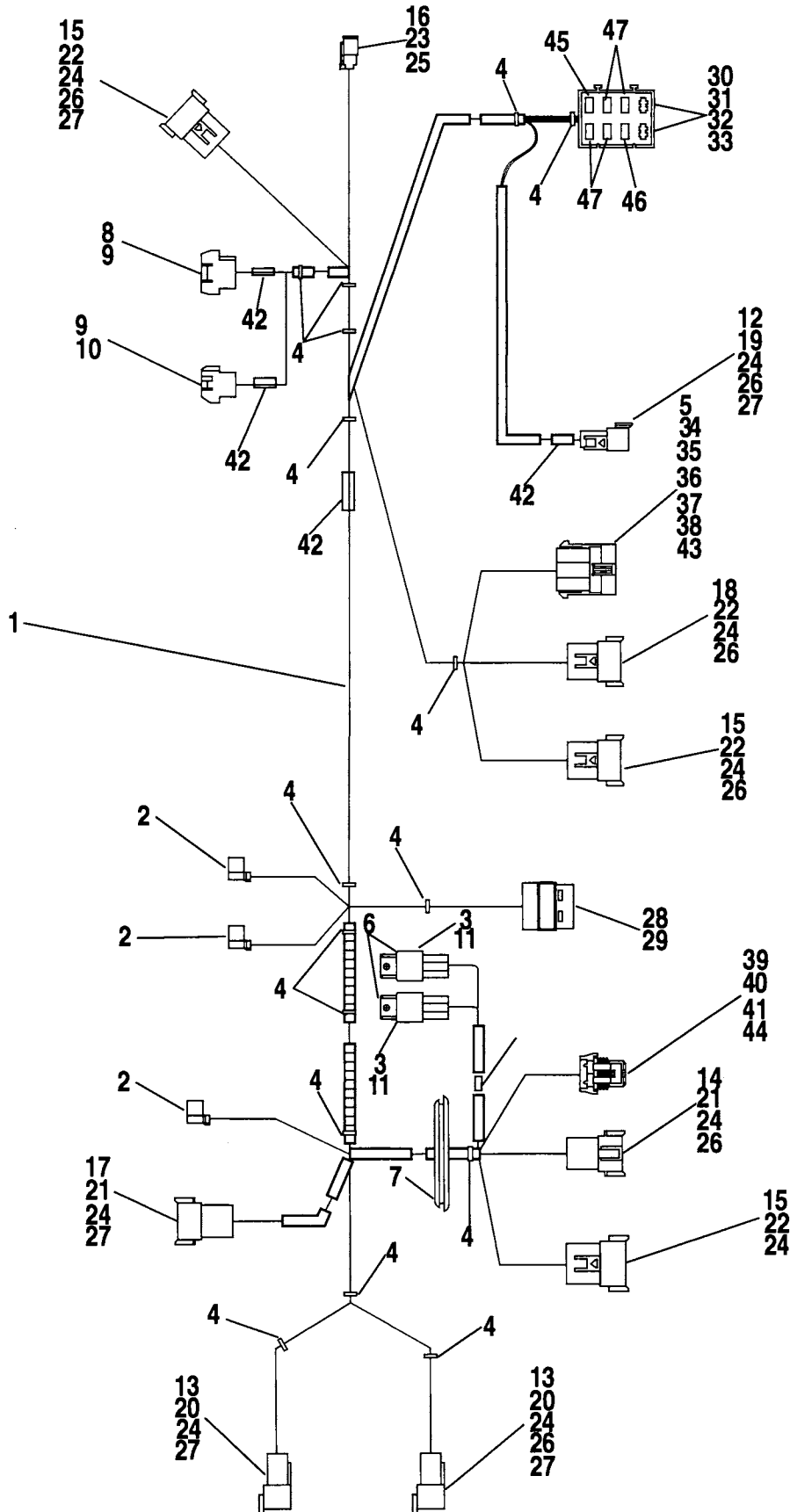

INDEX NO.	PART NO.	DESCRIPTION	FLT MODELS	FXR MODELS	SOFTAIL MODELS	DYNA MODELS
1	70282-94	WIRING HARNESS, interconnect includes the following:	94*-DM	--	--	--
2	9898	TERMINAL, female flag - #14-16 ga. wire (3)	94*-DM	--	--	--
3	9937	TERMINAL, female spade - 1/4" slot (9)	94*-DM	--	--	--
4	10065	CABLE STRAP (18)	94*-DM	--	--	--
5	10141	CLIP, metal connector	94*-DM	--	--	--
6	31504-91A	RELAY (2)	94*-DM	--	--	--
7	58468-94	GROMMET	94*-DM	--	--	--
8	70288-81	CONNECTOR, eight pin	94*-DM	--	--	--
9	72039-71	PIN, single socket (13)	94*-DM	--	--	--
10	72041-71	CONNECTOR, six pin	94*-DM	--	--	--
11	72046-79	INSULATOR, spade terminals (2)	94*-DM	--	--	--
12	72103-94BK	RECEPTACLE, 3-way pin	94*-DM	--	--	--
13	72106-94BK	RECEPTACLE, 6-way pin (2)*	94*-DM	--	--	--
14	72108-94BK	RECEPTACLE, 8-way pin	94*-DM	--	--	--
15	72109-94BK	RECEPTACLE, 12-way pin (3)	94*-DM	--	--	--
16	72112-94BK	PLUG, 2-way socket	94*-DM	--	--	--
17	72128-94GY	RECEPTACLE, 8-way pin	94*-DM	--	--	--
18	72129-94GY	RECEPTACLE, 12-way pin	94*-DM	--	--	--
19	72143-94	PIN LOCK, sec. 3-way	94*-DM	--	--	--
20	72146-94	PIN LOCK, sec. 6-way (2)	94*-DM	--	--	--
21	72148-94	PIN LOCK, sec. 8-way (2)	94*-DM	--	--	--
22	72149-94	PIN LOCK, sec. 12-way (4)	94*-DM	--	--	--
23	72152-94	SOCKET LOCK, sec. 2-way	94*-DM	--	--	--
24	72190-94	TERMINAL, pin (72)	94*-DM	--	--	--
25	72191-94	TERMINAL, socket (2)	94*-DM	--	--	--
26	72195-94	SEAL PIN (8)	94*-DM	--	--	--
27	72199-94	ATTACHMENT CLIP (3)	94*-DM	--	--	--
28	72205-94	CONNECTOR, plug, 4-way	94*-DM	--	--	--
29	72208-94	TERMINAL, male, 12 ga. (3)	94*-DM	--	--	--
30	72216-94	FUSE BLOCK (2)	94*-DM	--	--	--
31	72217-94	TERMINAL, auto fuse, 18-20 ga. (3)	94*-DM	--	--	--
32	72218-94	TERMINAL, auto fuse, 14-16 ga. (6)	94*-DM	--	--	--
33	72219-94	TERMINAL, auto fuse, 18 ga. (4)	94*-DM	--	--	--
34	72222-94	CONNECTOR, receptacle, 3-way	94*-DM	--	--	--
35	72225-94	TERMINAL, male, 12 ga. (2)	94*-DM	--	--	--
36	72226-94	TERMINAL, male, 14-16 ga.	94*-DM	--	--	--
37	72227-94	WIRE SEAL, 14 ga. (2)	94*-DM	--	--	--
38	72229-94	SECONDARY LOCK, 3-way	94*-DM	--	--	--
39	72234-94	CONNECTOR, plug, 2-way	94*-DM	--	--	--
40	72236-94	TERMINAL, female, 14-16 ga.	94*-DM	--	--	--
41	72238-94	SECONDARY LOCK, 2-way	94*-DM	--	--	--
42	72268-94	HEAT SHRINK TUBE, dual wall .7" x 2" (15)	94*-DM	--	--	--
43	72283-94	SEAL, cable	94*-DM	--	--	--
44	72284-94	SEAL, cable (2)	94*-DM	--	--	--
45	72300-89	FUSE, 1 amp	94*-DM	--	--	--
46	72340-94	FUSE, 10 amp	94*-DM	--	--	--
47	74587-94	CIRCUIT BREAKER, 15 amp (4)	94*-DM	--	--	--

FLT MODELS

FLHTC DJ
 FLTC-U DM
 FLHTC-U DP
 FLHS FA
 FLHR FD

FXR MODELS

FXR EA
 FXRS-SP EG
 FXLR EL
 FXRS-CON EM

SOFTAIL MODELS

FLSTC BJ
 FXSTC BK
 FXSTS BL
 FLSTF BM
 FLSTN BN

DYNA MODELS

FXDL GD
 FXDWG GE
 FXDS-CON GG

WIRING HARNESS, MAIN - FLT & FLHT

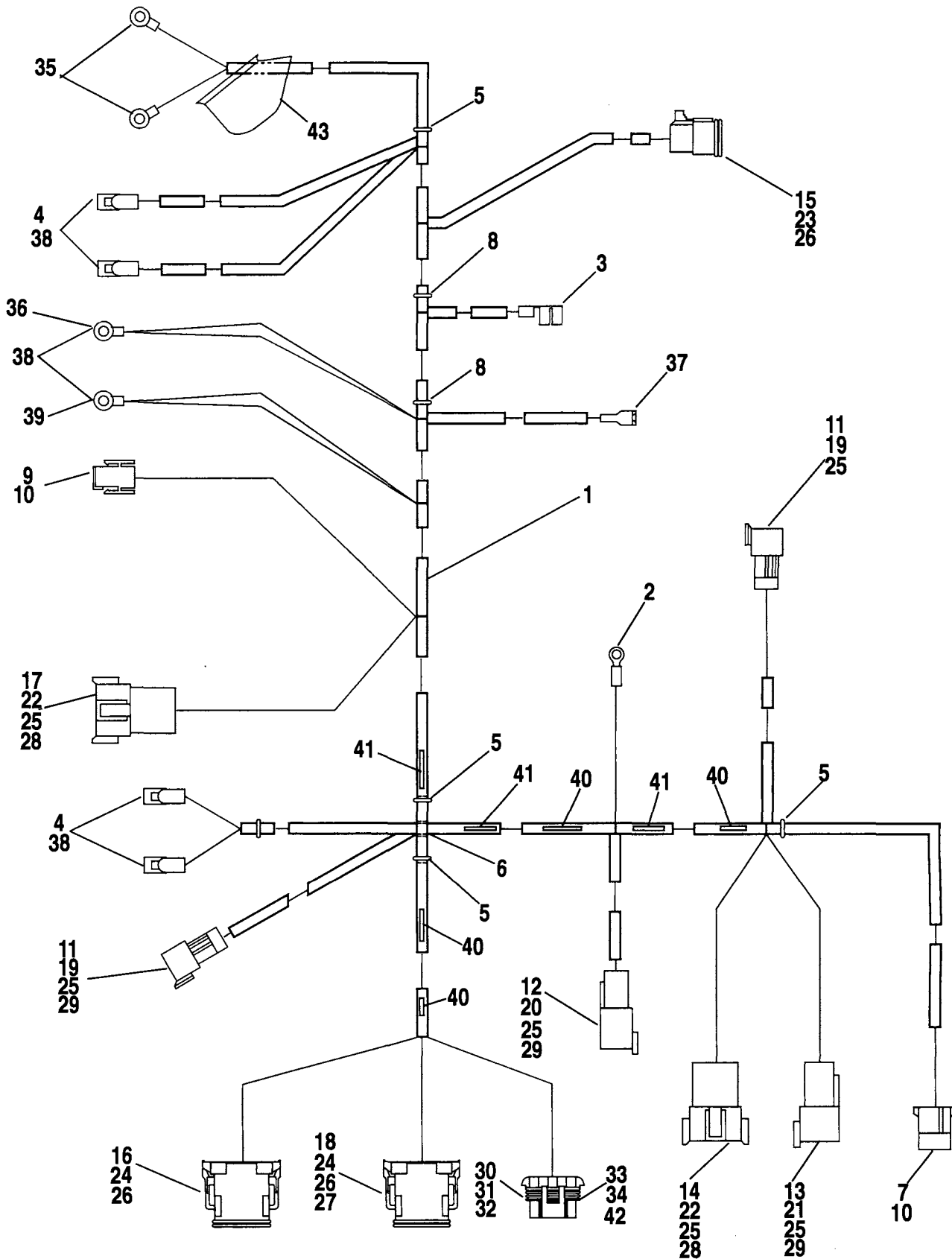

WIRING HARNESS, MAIN - 1994 FLT & FLHT MODELS

FB47E

INDEX NO.	PART NO.	DESCRIPTION	FLT MODELS	FXR MODELS	SOFTAIL MODELS	DYNA MODELS
1	70985-94	MAIN WIRING HARNESS includes the following:	94*-DJ/M/P	--	--	--
2	9866	TERMINAL, #10 ring type	94*-DJ/M/P	--	--	--
3	9905	TERMINAL, 1/4" cap type	94*-DJ/M/P	--	--	--
4	9937	TERMINAL, 1/4" ring, 14-18 ga. (5)	94*-DJ/M/P	--	--	--
5	10065	CABLE STRAP (5)	94*-DJ/M/P	--	--	--
6	10136	ANCHOR, T-stud	94*-DJ/M/P	--	--	--
7	70289-89	PLUG, 3-way socket	94*-DJ/M/P	--	--	--
8	70345-84	RETAINER (2)	94*-DJ/M/P	--	--	--
9	72034-71	CONNECTOR, two pin	94*-DJ/M/P	--	--	--
10	72038-71	SOCKET, single pin (5)	94*-DJ/M/P	--	--	--
11	72103-94BK	RECEPTACLE, 3-way pin (2)	94*-DJ/M/P	--	--	--
12	72104-94BK	RECEPTACLE, 4-way pin	94*-DJ/M/P	--	--	--
13	72106-94BK	RECEPTACLE, 6-way pin *	94*-DJ/M/P	--	--	--
14	72108-94BK	RECEPTACLE, 8-way pin	94*-DJ/M/P	--	--	--
15	72113-94BK	PLUG, 3-way socket	94*-DJ/M/P	--	--	--
16	72119-94BK	PLUG, 12-way socket	94*-DJ/M/P	--	--	--
17	72128-94GY	RECEPTACLE, 8-way pin	94*-DJ/M/P	--	--	--
18	72139-94GY	PLUG, 12-way socket	94*-DJ/M/P	--	--	--
19	72143-94	PIN LOCK, sec. 3-way (2)	94*-DJ/M/P	--	--	--
20	72144-94	PIN LOCK, sec. 4-way	94*-DJ/M/P	--	--	--
21	72146-94	PIN LOCK, sec. 6-way	94*-DJ/M/P	--	--	--
22	72148-94	PIN LOCK, sec. 8-way (2)	94*-DJ/M/P	--	--	--
23	72153-94	SOCKET LOCK, sec. 3-way	94*-DJ/M/P	--	--	--
24	72159-94	SOCKET LOCK, sec. 12-way (2)	94*-DJ/M/P	--	--	--
25	72190-94	TERMINAL, pin (32)	94*-DJ/M/P	--	--	--
26	72191-94	TERMINAL, socket (26)	94*-DJ/M/P	--	--	--
27	72195-94	SEAL PIN	94*-DJ/M/P	--	--	--
28	72198-94	ATTACHMENT CLIP, 8-way only (2)	94*-DJ/M/P	--	--	--
29	72199-94	ATTACHMENT CLIP (3)	94*-DJ/M/P	--	--	--
30	72221-94	CONNECTOR, plug, 3-way	94*-DJ/M/P	--	--	--
31	72223-94	TERMINAL, female, 10-12 ga. (2)	94*-DJ/M/P	--	--	--
32	72224-94	TERMINAL, female, 14-16 ga.	94*-DJ/M/P	--	--	--
33	72227-94	WIRE SEAL, 14 ga. (2)	94*-DJ/M/P	--	--	--
34	72229-94	SECONDARY LOCK, 3-way	94*-DJ/M/P	--	--	--
35	72241-94	TERMINAL, #10 ring, 18-20 ga.	94*-DJ/M/P	--	--	--
36	72242-94	TERMINAL, 1/4" ring w/ int. star, 10-12 ga.	94*-DJ/M/P	--	--	--
37	72243-94	TERMINAL, 1/4" female, 14-18 ga.	94*-DJ/M/P	--	--	--
38	72249-94	HEAT SHRINK TUBE, .3 x 1" (9)	94*-DJ/M/P	--	--	--
39	72255-94	TERMINAL, 1/4" ring w/ int. star, 18-20 ga.	94*-DJ/M/P	--	--	--
40	72266-94	HEAT SHRINK TUBE, dual wall, .3 x 2" (4)	94*-DJ/M/P	--	--	--
41	72268-94	HEAT SHRINK TUBE, dual wall, .7 x 2" (3)	94*-DJ/M/P	--	--	--
42	72283-94	REAR SEAL	94*-DJ/M/P	--	--	--
43	74407-86	BOOT, oil sending unit	94*-DJ/M/P	--	--	--

FLT MODELS

FLHTC DJ
 FLTC-U DM
 FLHTC-U DP
 FLHS FA
 FLHR FD

FXR MODELS

FXR EA
 FXRS-SP EG
 FXLR EL
 FXRS-CON EM

SOFTAIL MODELS

FLSTC BJ
 FXSTC BK
 FXSTS BL
 FLSTF BM
 FLSTN BN

DYNA MODELS

FXDL GD
 FXDWG GE
 FXDS-CON GG

WIRING HARNESS, MAIN - FLHR

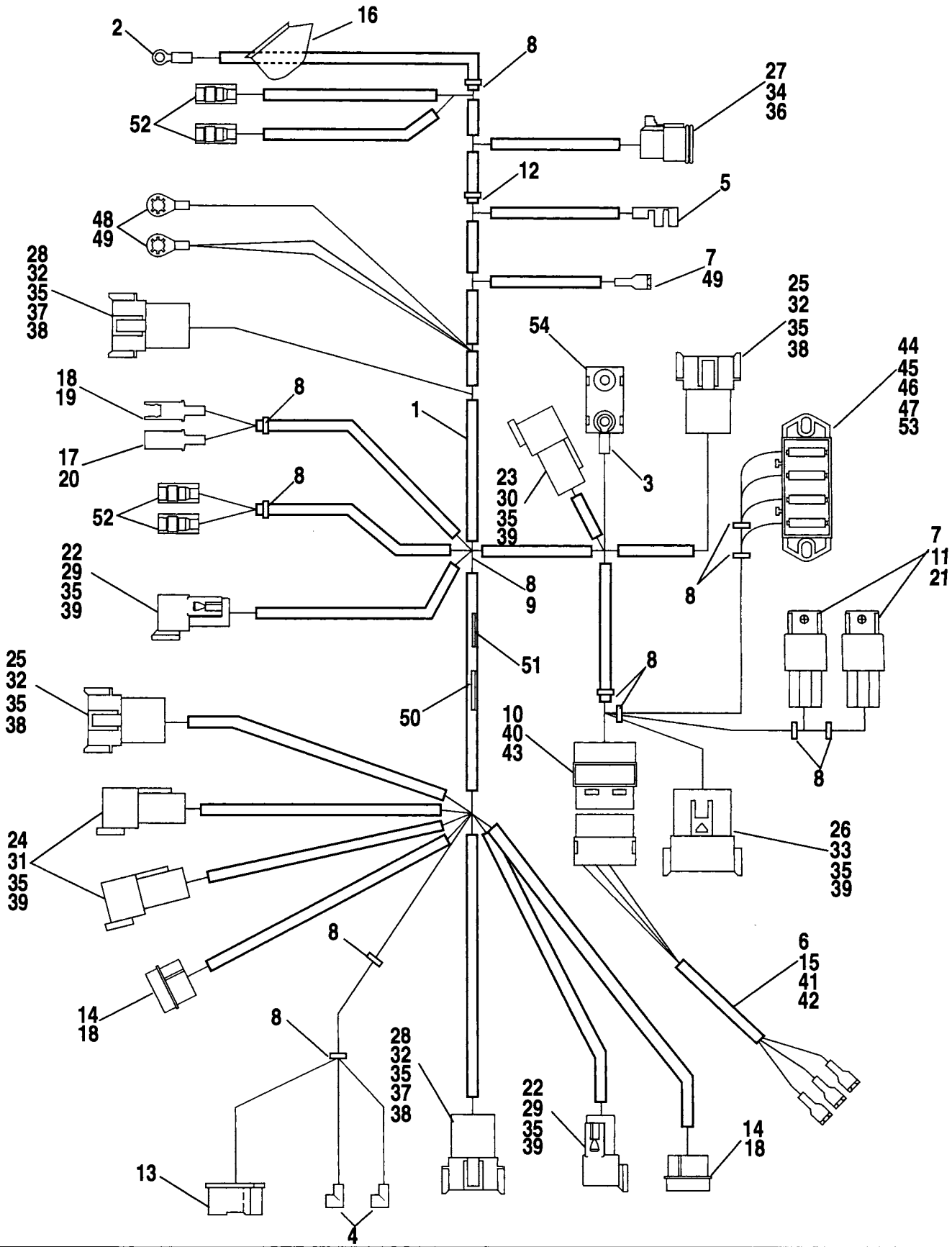

INDEX NO.	PART NO.	DESCRIPTION	FLT MODELS	FXR MODELS	SOFTAIL MODELS	DYNA MODELS
1	70245-94	MAIN WIRING HARNESS includes the following:	94*-FD	--	--	--
2	9857	TERMINAL, ring type, #10 hole	94*-FD	--	--	--
3	9866	TERMINAL, ring type, #10 hole	94*-FD	--	--	--
4	9898	TERMINAL, female flag, #14-16 wire (2)	94*-FD	--	--	--
5	9905	TERMINAL, cap type, 1/4" dia.	94*-FD	--	--	--
6	9907	TERMINAL, connector (3)	94*-FD	--	--	--
7	9937	TERMINAL, 1/4" ring, 14-16 ga. (9)	94*-FD	--	--	--
8	10065	CABLE STRAP (12)	94*-FD	--	--	--
9	10136	ANCHOR, T-stud	94*-FD	--	--	--
10	10147	CLIP, connector	94*-FD	--	--	--
11	31504-91A	RELAY w/ diode (2)	94*-FD	--	--	--
12	56073-83	RETAINER	94*-FD	--	--	--
13	68808-94	HEADLAMP CONNECTOR	94*-FD	--	--	--
14	70291-89	HOUSING, 4 pin (4)	94*-FD	--	--	--
15	70384-94	HARNESS, ignition switch	94*-FD	--	--	--
16	70579-65	BOOT (rubber)	94*-FD	--	--	--
17	72038-71	SOCKET, single pin	94*-FD	--	--	--
18	72039-71	PIN, single socket (7)	94*-FD	--	--	--
19	72043-71	CONNECTOR, single pin	94*-FD	--	--	--
20	72044-71	CONNECTOR, single socket	94*-FD	--	--	--
21	72046-79	CONNECTOR, spade terminals (2)	94*-FD	--	--	--
22	72103-94BK	RECEPTACLE, 3-way pin (2)	94*-FD	--	--	--
23	72104-94BK	RECEPTACLE, 4-way pin	94*-FD	--	--	--
24	72106-94BK	RECEPTACLE, 6-way pin (2)*	94*-FD	--	--	--
25	72108-94BK	RECEPTACLE, 8-way pin (2)	94*-FD	--	--	--
26	72109-94BK	RECEPTACLE, 12-way pin	94*-FD	--	--	--
27	72113-94BK	PLUG, 3-way socket	94*-FD	--	--	--
28	72128-94GY	PLUG, 8-way socket	94*-FD	--	--	--
29	72143-94	PIN LOCK, sec. 3-way (2)	94*-FD	--	--	--
30	72144-94	PIN LOCK, sec. 4-way	94*-FD	--	--	--
31	72146-94	PIN LOCK, sec. 6-way (2)	94*-FD	--	--	--
32	72148-94	PIN LOCK, sec. 8-way (4)	94*-FD	--	--	--
33	72149-94	PIN LOCK, sec. 12-way	94*-FD	--	--	--
34	72153-94	SOCKET LOCK, sec. 3-way	94*-FD	--	--	--

FLT MODELS
 FLHTC
 FLTC-U
 FLHTC-U
 FLHS
 FLHR

DJ
 DM
 DP
 FA
 FD

FXR MODELS
 FXR
 FXRS-SP
 FXLR
 FXRS-CON

EA
 EG
 EL
 EM

SOFTAIL MODELS
 FLSTC
 FXSTC
 FXSTS
 FLSTF
 FLSTN

BJ
 BK
 BL
 BM
 BN

DYNA MODELS
 FXDL
 FXDWG
 FXDS-CON

GD
 GE
 GG

WIRING HARNESS, MAIN - FLHR

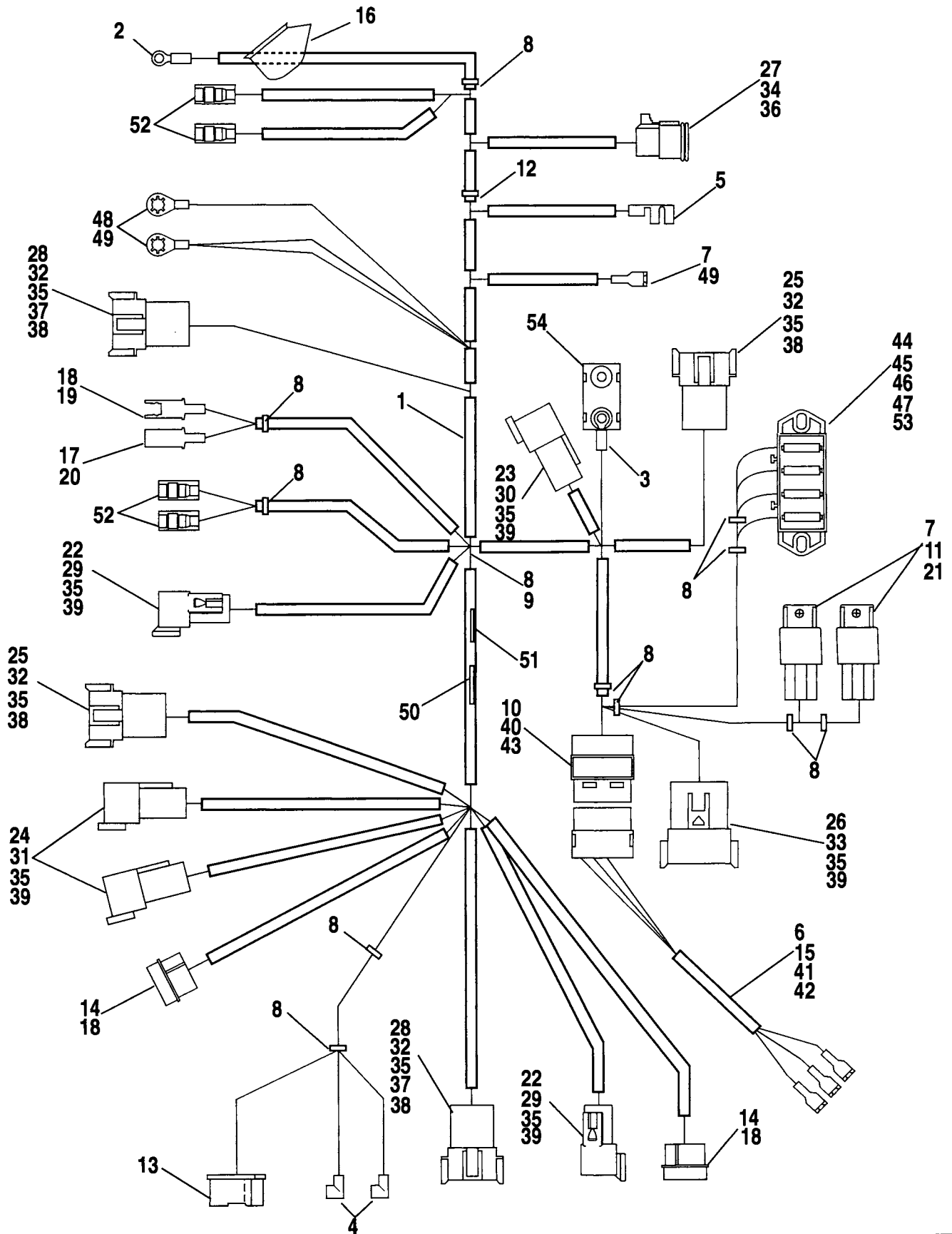

INDEX NO.	PART NO.	DESCRIPTION	FLT MODELS	FXR MODELS	SOFTAIL MODELS	DYNA MODELS
35	72190-94	TERMINAL, pin (64)	94*-FD	--	--	--
36	72191-94	TERMINAL, socket (3)	94*-FD	--	--	--
37	72195-94	SEAL PIN (2)	94*-FD	--	--	--
38	72198-94	ATTACHMENT CLIP (8-way) (4)	94*-FD	--	--	--
39	72199-94	ATTACHMENT CLIP (6)	94*-FD	--	--	--
40	72205-94	CONNECTOR, plug 4-way	94*-FD	--	--	--
41	72206-94	CONNECTOR, receptacle, 4-way	94*-FD	--	--	--
42	72207-94	TERMINAL, female, #14 ga. (3)	94*-FD	--	--	--
43	72208-94	TERMINAL, male, 12 ga. (3)	94*-FD	--	--	--
44	72215-94	FUSE BLOCK w/ feet	94*-FD	--	--	--
45	72217-94	TERMINAL, auto fuse, 18-20 ga. (2)	94*-FD	--	--	--
46	72218-94	TERMINAL, auto fuse, 14-16 ga. (4)	94*-FD	--	--	--
47	72219-94	TERMINAL, auto fuse, 18 ga. (2)	94*-FD	--	--	--
48	72242-94	TERMINAL, 1/4" ring w/ int. star, 18-20 ga. (2)	94*-FD	--	--	--
49	72249-94	HEAT SHRINK TUBE, .3 x 1" (3)*	94*-FD	--	--	--
50	72266-94	HEAT SHRINK TUBE, dual wall, .3 x 2" (14)	94*-FD	--	--	--
51	72268-94	HEAT SHRINK TUBE, dual wall, .7 x 2" (4)*	94*-FD	--	--	--
52	72290-94	TERMINAL, 1/4" female (4)	94*-FD	--	--	--
53	74587-94	CIRCUIT BREAKER, 15 amp.	94*-FD	--	--	--
53	74600-94	CIRCUIT BREAKER, 50 amp.	94*-FD	--	--	--

FLT MODELS

FLHTC DJ
 FLTC-U DM
 FLHTC-U DP
 FLHS FA
 FLHR FD

FXR MODELS

FXR EA
 FXRS-SP EG
 FXLR EL
 FXRS-CON EM

SOFTAIL MODELS

FLSTC BJ
 FXSTC BK
 FXSTS BL
 FLSTF BM
 FLSTN BN

DYNA MODELS

FXDL GD
 FXDWG GE
 FXDS-CON GG

MISCELLANEOUS ELECTRICAL

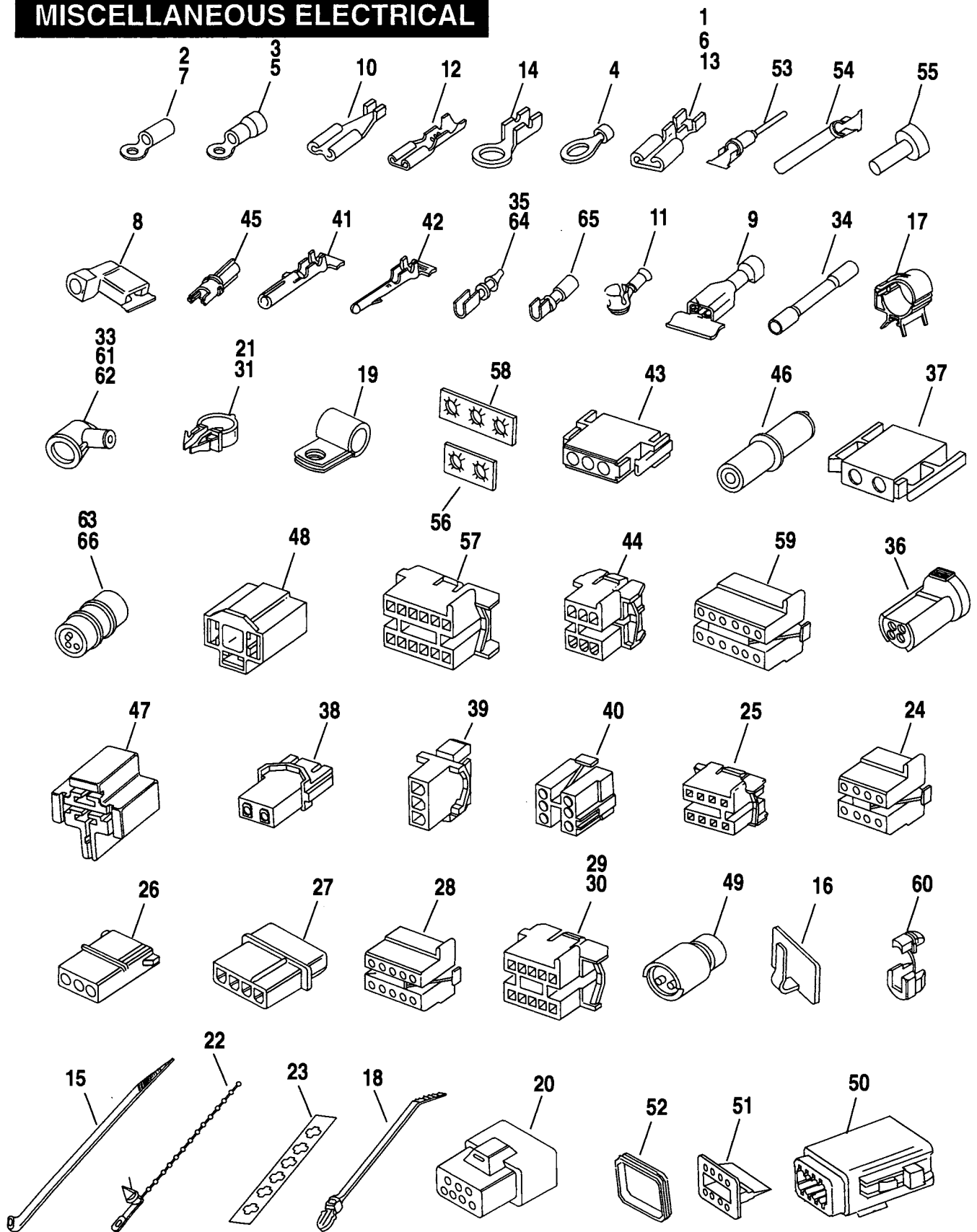

INDEX NO.	PART NO.	DESCRIPTION	FLT MODELS	FXR MODELS	SOFTAIL MODELS	DYNA MODELS
1	9847	TERMINAL, female spade	--	93*-ALL	--	--
	9848	TERMINAL, female spade	--	93*-ALL	--	--
	9938	TERMINAL, female spade	93-ALL	--	--	--
2	9852	TERMINAL, 45 degree spade	--	--	93*-ALL	--
	9856	TERMINAL, ring type - #6 hole	--	--	93*-ALL	--
	9857	TERMINAL, ring type - #10 hole	93-ALL	93*-ALL	93*-ALL	93*-ALL
	9858	TERMINAL, ring type - 1/4" dia. hole	93-ALL	93*-EA/G/M	--	93*-ALL
	9859	TERMINAL, ring type - 3/8" dia. hole	93-ALL	--	--	--
	9860	TERMINAL, ring type -3/8" dia. hole	93-ALL	--	93*-ALL	--
3	9862	TERMINAL, ring type - #10 hole	93-ALL	93*-ALL	93*-ALL	93*-ALL
	9863	TERMINAL, ring type - 1/4" dia. hole	93-ALL	93*-EA/G/M	93*-ALL	93*-ALL
	9864	TERMINAL, ring type - 5/16" dia. hole	93-ALL	--	93*-ALL	--
	9865	TERMINAL, ring type - 3/8" dia. hole	93-ALL	--	--	--
4	9866	TERMINAL, ring type - #10 hole	93-ALL	93*-ALL	93*-ALL	--
	9868	TERMINAL, ring type - 5/16" dia. hole	93-ALL	--	--	--
5	9871	TERMINAL, ring type - #6 hole	--	--	93*-ALL	--
6	9875	TERMINAL, female spade - 5/16" slot	--	93*-EA/G/M	93*-ALL	--
7	9892	TERMINAL, ring type - 1/2" dia. hole	93-ALL	--	--	--
8	9898	TERMINAL, female flag - #14-16 wire	93-ALL	93*-ALL	93*-ALL	93*-ALL
9	9900	TERMINAL, connector	93-ALL	93*-ALL	93*-ALL	--
	9907	TERMINAL, connector	93*-ALL	--	--	93*-ALL
10	9904	TERMINAL, female spade - 1/8" slot	93-ALL	--	--	--
11	9905	TERMINAL, cap type - 1/4" dia.	93-ALL	93*-ALL	93*-ALL	93*-ALL
12	9930	TERMINAL, female spade - 3/16" slot	93-ALL	--	--	--
13	9937	TERMINAL, female spade - 1/4" slot	93-ALL	93*-ALL	--	93*-ALL
	9938	TERMINAL, female spade - 1/4" slot	93-ALL	--	--	--
14	9945	TERMINAL, ring type - 5/16" dia. hole	93-ALL	--	--	--
15	10006	CABLE STRAP (black)	93-ALL	93*-ALL	93*-ALL	93*-ALL
	10039	CABLE STRAP	93-ALL	93*-EG/M	93*-ALL	93*-ALL
	10065	CABLE STRAP	93*-ALL	93*-ALL	93*-ALL	93*-ALL
	10076	CABLE STRAP	--	--	--	93*-ALL
16	10103	CLIP, adhesive back	94*-ALL	--	--	--
17	10108	CLIP, battery cable (3)	93-ALL	--	--	--
	10132	CABLE STRAP	93-ALL	--	--	--
18	10073	CABLE STRAP	93-ALL	93*-ALL	93*-ALL	93*-ALL
19	10077	CLAMP, wiring harness (3)	93-ALL	--	--	--
	68750-93	CLAMP (2)	93-ALL	--	--	--
20	31998-91	INSULATOR, receptacle hsg. (module conn.)	93-ALL	93*-ALL	93*-ALL	93*-ALL
21	56073-83	RETAINER	93-ALL	--	93*-ALL	--
22	70005-70	CABLE STRAP	93-ALL	93*-ALL	93*-ALL	--
23	70043-81	LABEL, battery - positive	93*-ALL	93*-ALL	93*-ALL	93*-ALL
24	70287-81	CONNECTOR, eight socket (2)	93*-ALL	93*-EL	--	93*-ALL
25	70288-81	CONNECTOR, eight pin (2)	93-ALL	93*-EL	--	--
26	70289-89	CONNECTOR, three socket	93-DM/P	--	--	93*-ALL
27	70291-89	CONNECTOR, four pin	--	--	--	93*-ALL
	70292-89	CONNECTOR, four pin	93-DM/P	--	--	93*-ALL
	70293-87	CONNECTOR, ten socket (2)	93-ALL	--	93*-ALL	93*-ALL
29	70294-87	CONNECTOR, ten pin	93-DM/P	--	--	--
30	70302-90	CONNECTOR, eight pin	--	--	--	93*-ALL
	70305-90	CONNECTOR, ten pin	--	--	--	93*-ALL

FLT MODELS

FLHTC
FLTC-U
FLHTC-U
FLHS
FLHR

DJ
DM
DP
FA
FD

FXR MODELS

FXR
FXRS-SP
FXLR
FXRS-CON
EA
EG
EL
EM

SOFTAIL MODELS

FLSTC
FXSTC
FXSTS
FLSTF
FLSTN
BJ
BK
BL
BM
BN

DYNA MODELS

FXDL
FXDWG
FXDS-CON
GD
GE
GG

MISCELLANEOUS ELECTRICAL

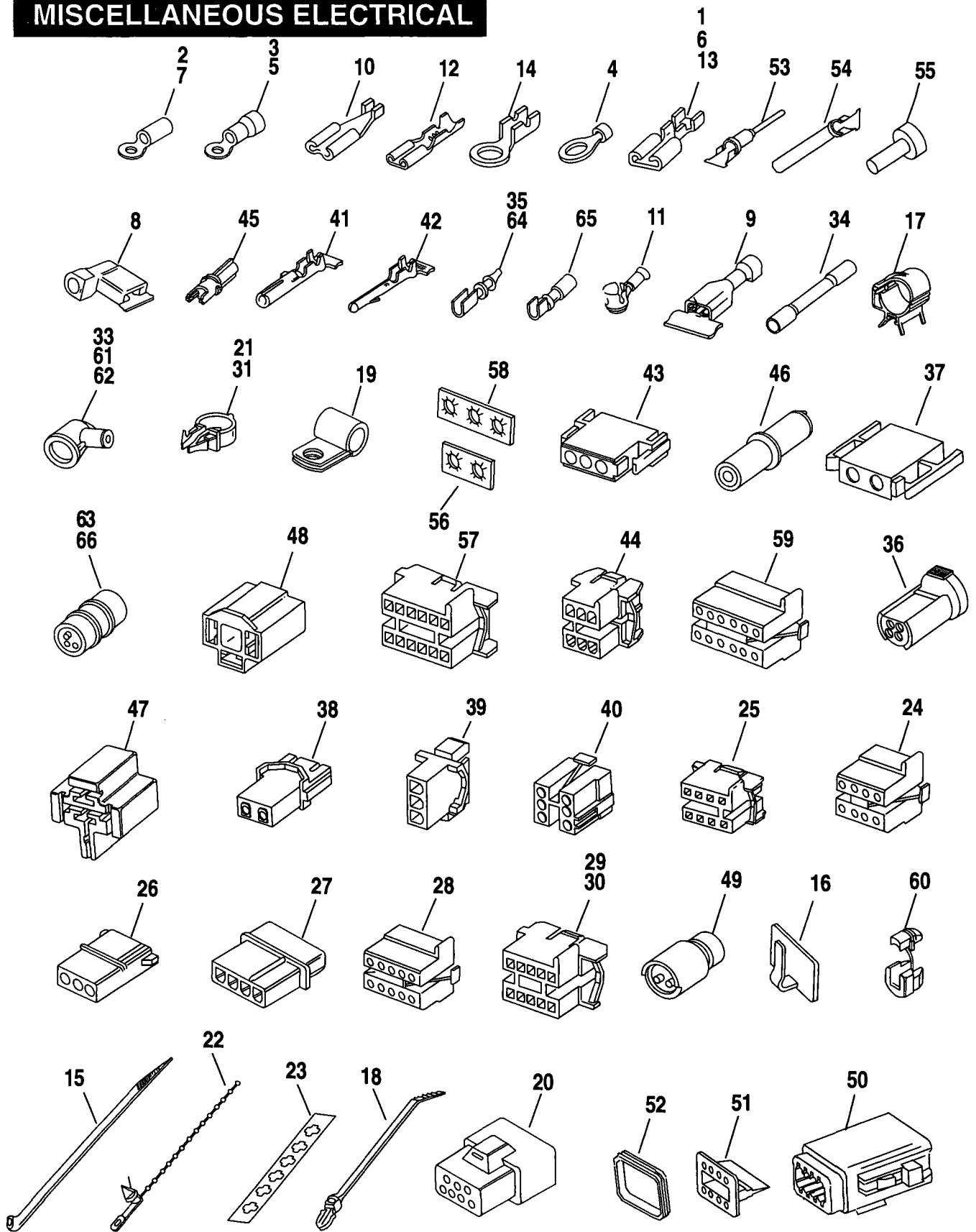

INDEX NO.	PART NO.	DESCRIPTION	FLT MODELS	FXR MODELS	SOFTAIL MODELS	DYNA MODELS
31	70345-84	RETAINER, wiring harness	93-ALL	93*-ALL	--	--
	70347-84	RETAINER, wiring harness	--	--	--	93*-ALL
33	70578-89	BOOT, insulating	93-ALL	93*-ALL	93*-ALL	93*ALL
	70579-65	BOOT, insulating	93-FA	93*-ALL	93*-ALL	--
	70580-89	BOOT, insulating (2)	--	--	--	93*-ALL
34	70583-93	CONNECTOR, sealed	--	93*-ALL	--	--
	70585-93	CONNECTOR, splice, 18-22 ga. (red)	94*-ALL	94*-ALL	94*-ALL	94*-ALL
	70586-93	CONNECTOR, splice, 14-16 ga. (blue)	94*-ALL	94*-ALL	94*-ALL	94*-ALL
	70587-93	CONNECTOR, splice, 10-12 ga. (yellow)	94*-ALL	94*-ALL	94*-ALL	94*-ALL
35	72028-83	SOCKET	93-ALL	--	--	--
36	72029-84	PLUG, four wire	93-ALL	--	--	--
37	72034-71	CONNECTOR, two pin	93-ALL	93*-EA/G/M	93*-BJ	--
38	72035-71	CONNECTOR, two socket	93-ALL	93*-EA/G/M	93*-BJ	93*-ALL
	72045-90	CONNECTOR, two socket	93-DM/P	--	--	--
39	72036-71	CONNECTOR, three pin	93-DJ	--	--	--
	72048-90	CONNECTOR, three pin	93-DM/P	--	--	--
40	72037-71	CONNECTOR, six socket	93-DJ/M	93*-ALL	93*-ALL	--
41	72038-71	SOCKET, single pin	93-ALL	93*-ALL	93*-ALL	93*-ALL
42	72039-71	PIN, single socket	93-ALL	93*-ALL	93*-ALL	93*-ALL
	72040-71	CONNECTOR, three socket	93-DJ/P	--	--	--
44	72041-71	CONNECTOR, six pin	93-ALL	93*-ALL	--	--
45	72043-71	CONNECTOR, single pin	93-ALL	93*-ALL	93*-ALL	93*-ALL
46	72044-71	CONNECTOR, single socket	93-ALL	93*-EA/G/M	93*-ALL	93*-ALL
47	72046-79	CONNECTOR, spade terminals	93-ALL	93*-ALL	93*-ALL	93*-ALL
48	72056-92	CONNECTOR, spade terminals	--	93*-ALL	--	--
49	72051-77	CONNECTOR, three socket	93-ALL	93*-ALL	93*-ALL	93*-ALL
50	72118-94BK	PLUG, 8-way socket - rear lights	94*-ALL	--	--	--
51	72158-94	SOCKET LOCK, 8-way - rear lights	94*-ALL	--	--	--
52	72172-94	FRONT SEAL, 2-way plug	94*-ALL	--	--	--
	72173-94	FRONT SEAL, 3-way plug	94*-ALL	--	--	--
	72174-94	FRONT SEAL, 4-way plug	94*-ALL	--	--	--
	72176-94	FRONT SEAL, 6way plug	94*-ALL	--	--	--
	72178-94	FRONT SEAL, 8-way plug	94*-ALL	--	--	--
	72179-94	FRONT SEAL, 12-way plug	94*-ALL	--	--	--
53	72190-94	TERMINAL, pin	94*-ALL	--	--	--
54	72191-94	TERMINAL, socket	94*-ALL	--	--	--
55	72195-94	SEAL PIN	94*-ALL	--	--	--
56	72275-74	CONNECTOR TAB, two terminal	93-ALL	93*-ALL	93*-BJ	--
57	72276-74	CONNECTOR, twelve pin	93-ALL	93*-EA/G/M	93*-BJ	93*-ALL
58	72277-74	CONNECTOR TAB, three terminal	93-ALL	93*-EA/G/M	93*-BJ	--
59	72278-74	CONNECTOR, twelve socket	93-ALL	93*-EA/G/M	93*-ALL	--
60	72503-90	CABLE RESTRAINT	--	--	--	93*-ALL
61	74407-86	BOOT, oil sending unit	93-ALL	--	--	--
62	74412-91	BOOT, module harness	--	--	93*-ALL	--
63	74521-77	CONNECTOR, pin & socket	--	93*-ALL	93*-ALL	--
64	74536-77A	SOCKET, single pin	93-ALL	93*-ALL	93*-ALL	93*-ALL
65	74539-77A	PIN, single socket	93-ALL	93*-ALL	93*-ALL	93*-ALL
66	90771-79	PLUG, wiring harness	93-ALL	--	--	--

FLT MODELS
 FLHTC DJ
 FLTC-U DM
 FLHTC-U DP
 FLHS FA
 FLHR FD

FXR MODELS
 FXR EA
 FXRS-SP EG
 FXLR EL
 FXRS-CON EM

SOFTAIL MODELS
 FLSTC BJ
 FXSTC BK
 FXSTS BL
 FLSTF BM
 FLSTN BN

DYNA MODELS
 FXDL GD
 FXDWG GE
 FXDS-CON GG

SOUND SYSTEM

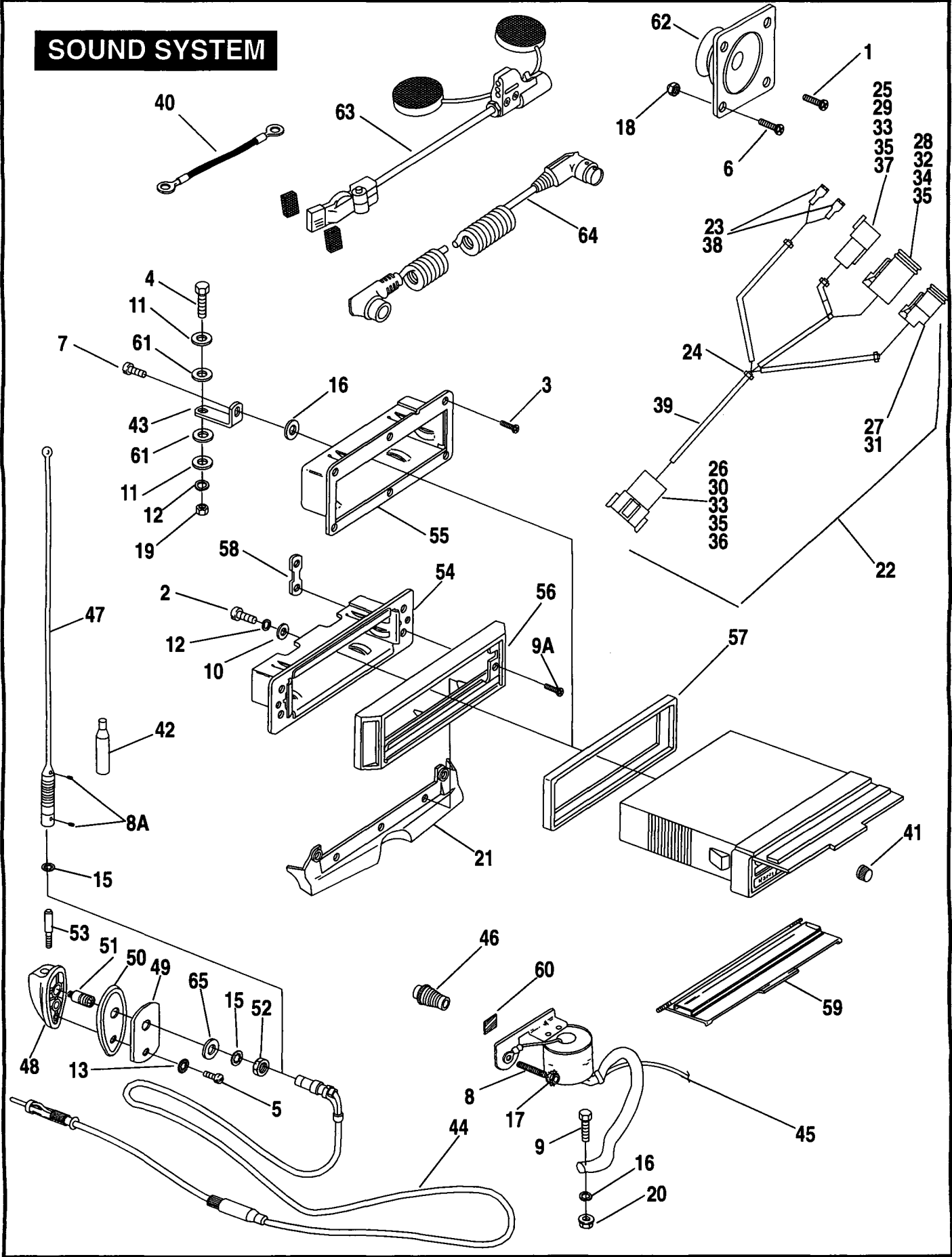

INDEX NO.	PART NO.	DESCRIPTION	FLT MODELS	FXR MODELS	SOFTAIL MODELS	DYNA MODELS
1	922	SCREW, speaker mounting - rear (8)	93*-DM/P	--	--	--
2	924	SCREW	93*-DJ/P	--	--	--
3	2508	SCREW (6)	93*-DM	--	--	--
4	2551W	SCREW (2 - DM)	93*-DM/P	--	--	--
5	2576	SCREW	93*-DJ/M/P	--	--	--
6	2646	SCREW, speaker mounting - front (8)	93*-DM	--	--	--
	5209	SCREW, speaker mounting - front (6)	93*-DJ/P	--	--	--
7	2774	SCREW	93*-DM	--	--	--
8	3227	STUD	93*-DM/P	--	--	--
8A	3266	SET SCREW (2-DJ;4-DM/P)	93*-DJ/M/P	--	--	--
9	3574	SCREW	93*-DM/P	--	--	--
9A	4015	SCREW (4)	93*-DJ/P	--	--	--
10	6036	WASHER	93*-DJ/P	--	--	--
11	6235	WASHER (2)	93*-DM	--	--	--
12	7036	LOCKWASHER	93*-DJ/P	--	--	--
13	7118	LOCKWASHER	93*-DJ	--	--	--
15	7129	LOCKWASHER (2)	93*-DJ/M/P	--	--	--
16	7229W	LOCKWASHER (2-DM)	93*-DM	--	--	--
17	7492	NUT	93*-DM/P	--	--	--
18	7609W	LOCKNUT (8)	93*-DM	--	--	--
19	7686	LOCKNUT	93*-DM	--	--	--
20	7716	NUT, flange	93*-DM/P	--	--	--
21	56109-88	HANDLEBAR COVER (black)	93*-DJ/P	--	--	--
	70160-91	WIRING HARNESS, audio (not illus.)	93-DM/P	--	--	--
22	70160-94	WIRING HARNESS, audio includes the following:	94*-DM/P	--	--	--
23	9937	TERMINAL, 1/4" ring, 14-18 ga. (2)	94*-DM/P	--	--	--
24	10065	CABLE STRAP	94*-DM/P	--	--	--
25	72106-94BK	RECEPTACLE, 6-way pin	94*-DM/P	--	--	--
26	72108-94BK	RECEPTACLE, 8-way pin	94*-DM/P	--	--	--
27	72112-94BK	PLUG, 2-way socket *	94*-DM/P	--	--	--
28	72116-94BK	PLUG, 6-way socket	94*-DM/P	--	--	--
29	72146-94	PIN LOCK, sec. 6-way	94*-DM/P	--	--	--
30	72148-94	PIN LOCK, sec. 8-way	94*-DM/P	--	--	--
31	72152-94	SOCKET LOCK, 2-way	94*-DM/P	--	--	--
32	72156-94	SOCKET LOCK, 6-way	94*-DM/P	--	--	--
33	72190-94	TERMINAL, pin (11)	94*-DM/P	--	--	--
34	72191-94	TERMINAL, socket (7)	94*-DM/P	--	--	--
35	72195-94	SEAL PIN (4)	94*-DM/P	--	--	--
36	72198-94	ATTACHMENT CLIP (8-way only)	94*-DM/P	--	--	--
37	72199-94	ATTACHMENT CLIP	94*-DM/P	--	--	--
38	72249-94	HEAT SHRINK TUBE, .3 x 1" (2)	94*-DM/P	--	--	--
39	72266-94	HEAT SHRINK TUBE, dual wall, .3 x 2" (7)	94*-DM/P	--	--	--

FLT MODELS

FLHTC
FLTC-U
FLHTC-U
FLHS
FLHR

DJ
DM
DP
FA
FD

FXR MODELS

FXR
FXRS-SP
FXLR
FXRS-CON
EA
EG
EL
EM

SOFTAIL MODELS

FLSTC
FXSTC
FXSTS
FLSTF
FLSTN
BJ
BK
BL
BM
BN

DYNA MODELS

FXDL
FXDWG
FXDS-CON
GD
GE
GG

SOUND SYSTEM

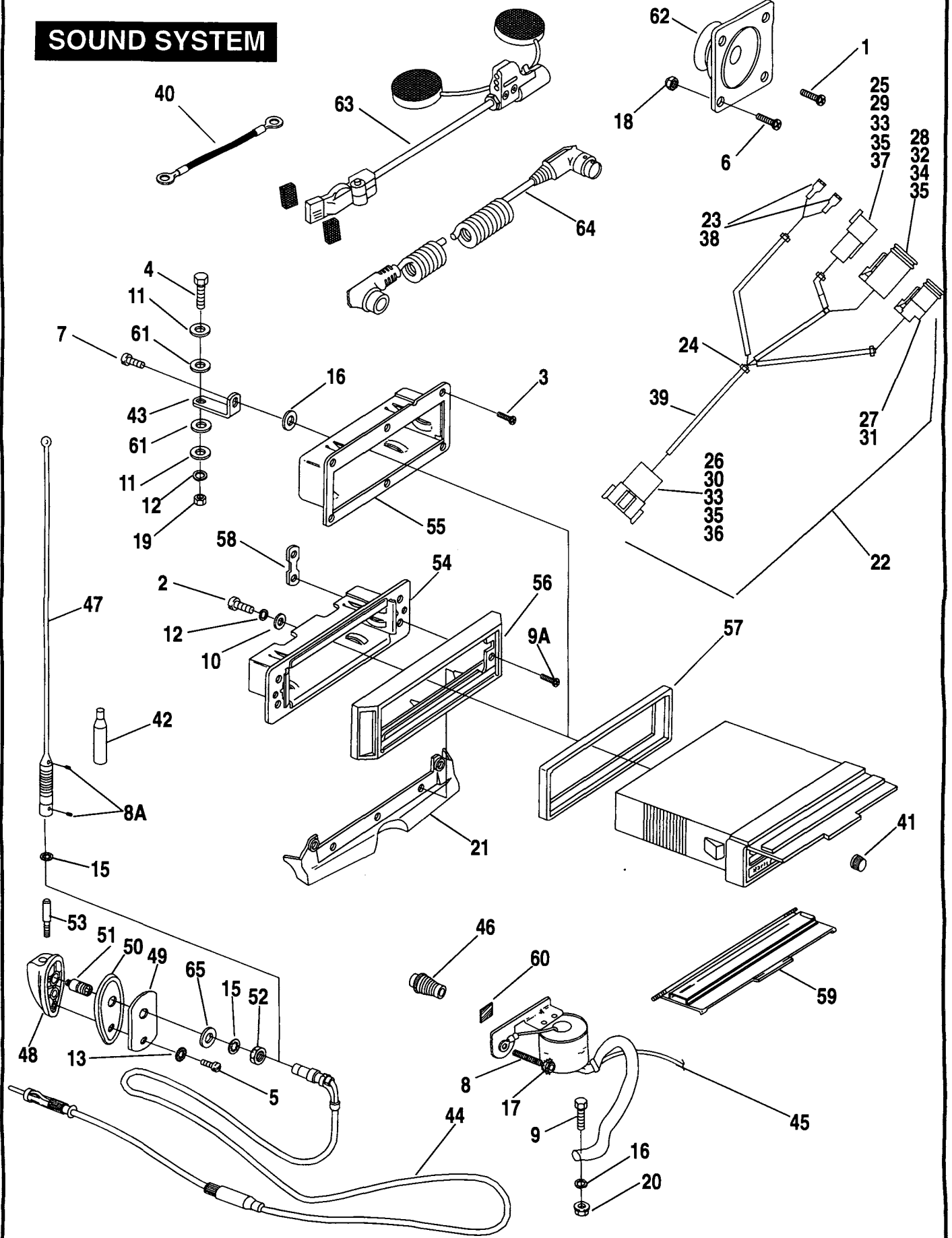

INDEX NO.	PART NO.	DESCRIPTION	FLT MODELS	FXR MODELS	SOFTAIL MODELS	DYNA MODELS
40	70168-89	WIRING ASSEMBLY, radio ground	93*-DM	--	--	--
	70296-89	WIRING HARNESS, power (not illus.)	93-DM/P	--	--	--
	70341-89	WIRING ASSEMBLY, radio ground (not illus.)	93-DJ/P	--	--	--
41	71809-88	CONTROL KNOB (2)	93*-DJ/M/P	--	--	--
42	74414-93	BOOT, antenna (2 - DM/P)	93*-DM/P	--	--	--
43	76240-88	BRACKET, rear	93*-DM	--	--	--
44	76248-86	CABLE, antenna	93*-DJ/M/P	--	--	--
45	76294-93	CABLE, antenna w/ coil	93*-DM/P	--	--	--
46	76249-86A	GROMMET, split (2 - DP; 3 - DM)	93*-DJ/M/P	--	--	--
47	76250-86C	ANTENNA (2 - DM/P)	93*-DJ/M/P	--	--	--
48	76252-86	BASE, antenna	93*-DJ	--	--	--
49	76253-86	REINFORCEMENT PLATE	93*-DJ	--	--	--
50	76255-86	GASKET, base	93*-DJ	--	--	--
51	76258-86	PLUG ASSEMBLY	93*-DJ/M/P	--	--	--
52	76259-86	NUT	93*-DM/P	--	--	--
53	76260-89	ANTENNA ADAPTOR (2)	93*-DM/P	--	--	--
54	76274-88	BRACKET, mounting	93*-DJ/P	--	--	--
55	76277-88	BRACKET, mounting	93*-DM	--	--	--
56	76280-88	NOSE SEAL	93*-DJ/P	--	--	--
57	76281-88	NOSE SEAL	93*-DM	--	--	--
58	76282-88	NUT PLATE (2)	93*-DJ/P	--	--	--
59	76283-89	FRONT COVER	93-DJ/M/P	--	--	--
60	76305-93	CUSHION	93*-DM/P	--	--	--
61	77004-80	WASHER (rubber) (2)	93*-DM	--	--	--
62	77029-86A	SPEAKER (2; 4 - DM/P)	93*-DJ/M/P	--	--	--
63	77147-91	HEADSET w/ #64 (2 - HDI)	93*-DM/P	--	--	--
64	77148-91	COILED CORD, headset (2 - HDI)	93*-DM/P	--	--	--
65	90763-79	WASHER	93*-DM/P	--	--	--

NOTE: For all service and warranty claims on the radio chassis, contact:
RADIO SOUND, INC.
 1031 West Main Street
 Louisville, KY 40202
 Phone: (502) 589-9946 or 1-800-367-4506

FLT MODELS

FLHTC DJ
 FLTC-U DM
 FLHTC-U DP
 FLHS FA
 FLHR FD

FXR MODELS

FXR EA
 FXRS-SP EG
 FXLR EL
 FXRS-CON EM

SOFTAIL MODELS

FLSTC BJ
 FXSTC BK
 FXSTS BL
 FLSTF BM
 FLSTN BN

DYNA MODELS

FXDL GD
 FXDWG GE
 FXDS-CON GG

C. B. & INTERCOM SYSTEMS

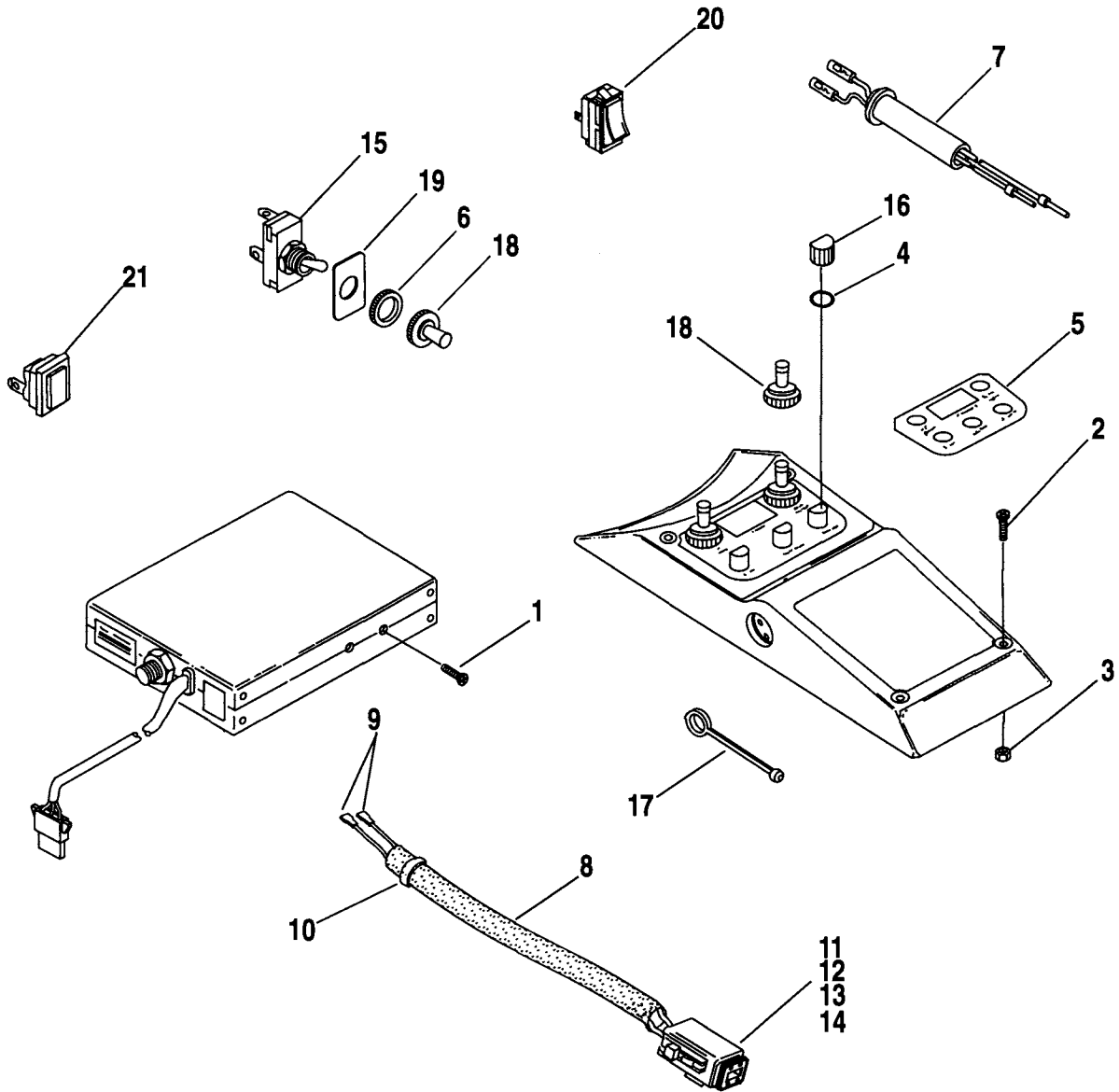

INDEX NO.	PART NO.	DESCRIPTION	FLT MODELS	FXR MODELS	SOFTAIL MODELS	DYNA MODELS
1	2787	SCREW, C.B. mounting (4)	93*-DM/P	--	--	--
2	3548A	SCREW (4)	93*-DM/P	--	--	--
3	7830	NUT (4)	93*-DM/P	--	--	--
4	11176	O-RING (6)	93-DM/P	--	--	--
5	14303-91	TRIM, C.B. console	93*-DM/P	--	--	--
6	67846-70	NUT	93*-DM	--	--	--
7	70642-91	CABLE ASSEMBLY P.T.T.-CB	93-DM/P	--	--	--
8	70642-94	CABLE ASSEMBLY P.T.T.-CB includes the following:	94*-DM/P	--	--	--
9	9904	TERMINAL, female spade, 1/8" slot (2)	94*-DM/P	--	--	--
10	10065	CABLE STRAP	94*-DM/P	--	--	--
11	72112-94BK	RECEPTACLE, 2-way pin *	94*-DM/P	--	--	--
12	72142-94	PIN LOCK, sec. 2-way	94*-DM/P	--	--	--
13	72190-94	TERMINAL, pin (2)	94*-DM/P	--	--	--
14	72199-94	ATTACHMENT CLIP	94*-DM/P	--	--	--
	70650-91	CABLE, P.T.T. to frg. (not illus.)	93-DM/P	--	--	--
15	71521-89	SWITCH, speakers	93*-DM	--	--	--
16	71809-88	KNOB, radio (3)	93*-DM/P	--	--	--
17	72059-89A	PLUG, weather	93-DM/P	--	--	--
18	74408-89	BOOT, toggle switch (4)	93*-DM/P	--	--	--
19	76297-89	LABEL, speaker	93*-DM	--	--	--
20	77092-89	SWITCH, speaker control (on fairing)	93*-DP	--	--	--
21	77100-89A	HANDLEBAR SWITCH, P.T.T.	93*-DM/P	--	--	--
H-D INTERNATIONAL ONLY						
3	14304-91	TRIM, intercom. console (Japan only)	93*-DM/P	--	--	--
	14305-90	TRIM, console (Japan only)	93*-DM/P	--	--	--

NOTE: For all service and warranty claims on the C.B./intercom. pod or C.B. chassis, contact:
 RADIO SOUND, INC.
 1031 West Main Street
 Louisville, KY 40202
 Phone: (502) 589-9946 or 1-800-367-4506

FLT MODELS

FLHTC DJ
 FLTC-U DM
 FLHTC-U DP
 FLHS FA
 FLHR FD

FXR MODELS

FXR EA
 FXRS-SP EG
 FXLR EL
 FXRS-CON EM

SOFTAIL MODELS

FLSTC BJ
 FXSTC BK
 FXSTS BL
 FLSTF BM
 FLSTN BN

DYNA MODELS

FXDL GD
 FXDWG GE
 FXDS-CON GG

HANDLEBAR SWITCHES

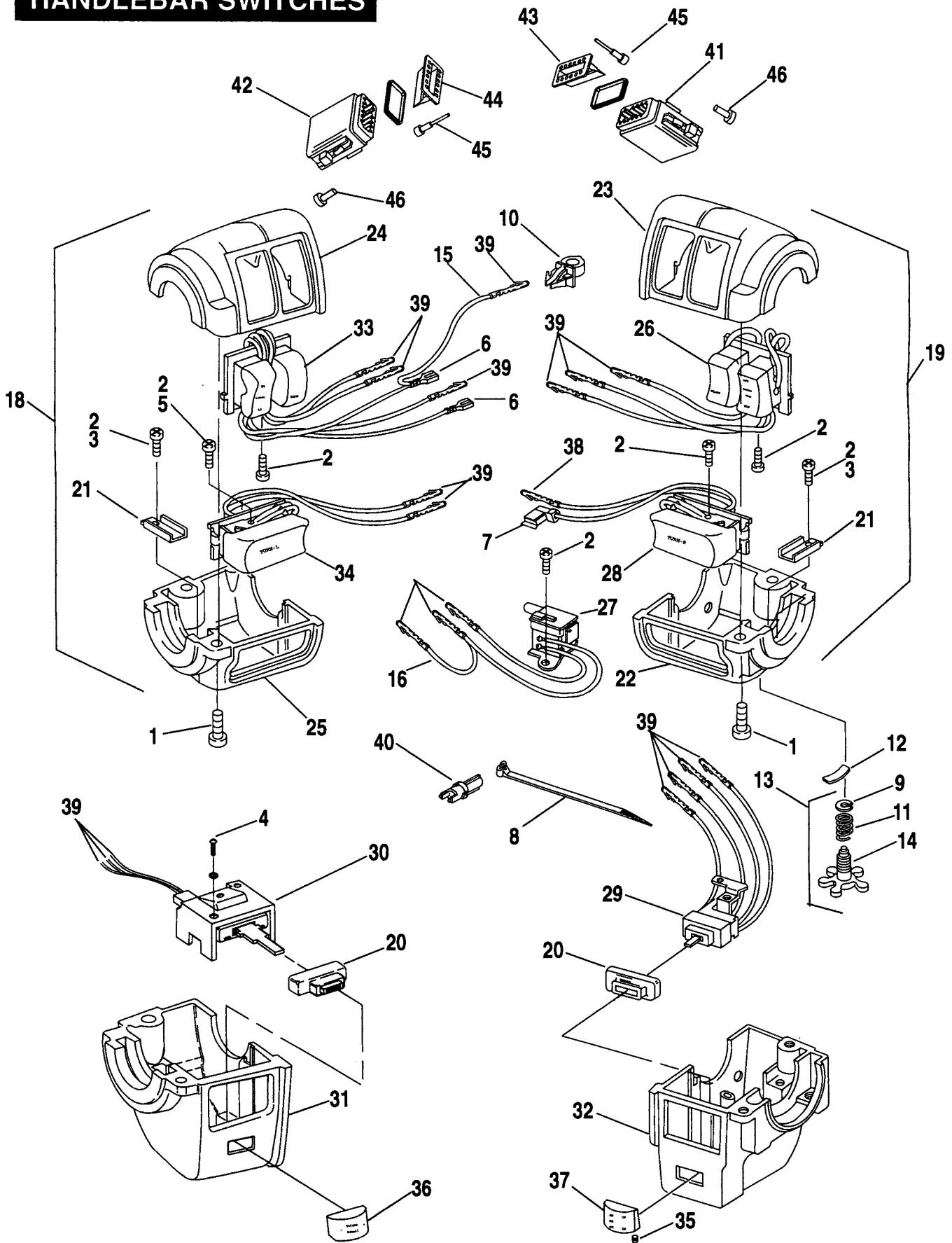

INDEX NO.	PART NO.	DESCRIPTION	FLT MODELS	FXR MODELS	SOFTAIL MODELS	DYNA MODELS
1	2508	SCREW (4)	93*-DJ/M/P	--	--	--
2	2907	SCREW (7; 4 - radio equipped)	93*-ALL	93*-ALL	93*-ALL	93*-ALL
3	2908	SCREW (2)	93*-DJ/M/P	--	--	--
4	2909	SCREW	93*-DJ/M/P	--	--	--
5	2910	SCREW	93*-DJ/M/P	--	--	--
6	9875	TERMINAL, female spade (2)	93*-ALL	93*-ALL	93*-ALL	93*-ALL
7	9898	TERMINAL, flag	93*-ALL	93*-ALL	93*-ALL	93*-ALL
8	10065	CABLE STRAP (2)	--	93*-ALL	93*-BJ/K/M/N	93*-ALL
9	11155	RETAINING RING	93*-DJ,FA/D	93*-ALL	93*-ALL	93*-ALL
10	56073-83	RETAINER, wiring harness (4)	--	93*-EA/L	93*-ALL	93*-ALL
11	56394-74	SPRING, adjusting screw	93*-DJ,FA/D	93*-ALL	93*-ALL	93*-ALL
12	56396-74A	SPRING, throttle grip	93*-DJ,FA/D	93*-ALL	93*-ALL	93*-ALL
13	56397-74C	ADJUSTING SCREW KIT w/ #9, 11 & 14	93*-DJ,FA/D	93*-ALL	93*-ALL	93*-ALL
14	56402-83A	SCREW, throttle adjusting	93*-DJ,FA/D	93*-ALL	93*-ALL	93*-ALL
15	70047-82	WIRE ASSEMBLY, 5" lg. (white)	93*-ALL	93*-ALL	93*-ALL	93*-ALL
16	70082-82	WIRE ASSEMBLY, 3" lg (orange)	--	--	93*-ALL	--
18	70218-87A	SWITCH ASSEMBLY KIT, complete - left	93-FA	93*-ALL	93*-ALL	93*-ALL
19	70219-87	SWITCH ASSEMBLY KIT, complete - right	93-FA	93*-ALL	93*-ALL	93*-ALL
20	70654-86	BOOT, switch (2)	93*-DJ/M/P	--	--	--
21	71557-93	PLATE, switch (2)	93*-FA/D	93*-ALL	93*-ALL	93*-ALL
22	71563-82A	HOUSING, lower - right	93*-FA/D	93*-ALL	93*-ALL	93*-ALL
23	71564-82A	HOUSING, upper - right	93*-ALL	93*-ALL	93*-ALL	93*-ALL
24	71567-82	HOUSING, upper - left	93*-ALL	93*-ALL	93*-ALL	93*-ALL
25	71568-82A	HOUSING, lower - left	93*-FA/D	93*-ALL	93*-ALL	93*-ALL
26	71589-92	SWITCH ASSEMBLY, engine stop/start	93*-ALL	93*-ALL	93*-ALL	93*-ALL
27	71590-92	STOPLAMP SWITCH	93*-ALL	93*-ALL	93*-ALL	93*-ALL
28	71591-92	SWITCH ASSEMBLY, right turn signal	93*-ALL	93*-ALL	93*-ALL	93*-ALL
29	71592-88	3-WAY FUNCTION SWITCH	93*-DJ/M/P	--	--	--
30	71593-88	VOLUME CONTROL	93*-DJ/M/P	--	--	--
31	71594-88	HOUSING, lower - left	93*-DJ/M/P	--	--	--
32	71595-86	HOUSING, lower - right	93*-DJ/M/P	--	--	--
33	71597-92	SWITCH ASSEMBLY, dimmer & horn	93*-ALL	93*-ALL	93*-ALL	93*-ALL
34	71598-92	SWITCH ASSEMBLY, left turn signal	93*-ALL	93*-ALL	93*-ALL	93*-ALL
35	71805-88	SET SCREW (2)	93*-DJ/M/P	--	--	--
36	71806-88	KNOB, volume	93*-DJ/M/P	--	--	--
37	71807-88	KNOB, am/fm/wb	93*-DJ/M/P	--	--	--
38	72038-71	SOCKET, single pin	93-ALL	93*-ALL	93*-ALL	93*-ALL
39	72039-71	PIN, single socket (14)	93-ALL	93*-ALL	93*-ALL	93*-ALL
40	72043-71	CONNECTOR, single pin	93-ALL	93*-ALL	93*-ALL	93*-ALL
41	72116-94BK	PLUG, 6-way socket (2)	94*-ALL	--	--	--
42	72119-94BK	PLUG, 12-way socket	94*-DJ/M/P	--	--	--
43	72156-94	SOCKET LOCK, sec. 6-way (2)	94*-ALL	--	--	--
44	72159-94	SOCKET LOCK, sec. 12-way	94*-DJ/M/P	--	--	--
45	72191-94	TERMINAL, socket (20-DJ/M/P;12-FD)	94*-ALL	--	--	--
46	72195-94	SEAL PIN (4)	94*-DJ/M/P	--	--	--

FLT MODELS

FLHTC DJ
 FLTC-U DM
 FLHTC-U DP
 FLHS FA
 FLHR FD

FXR MODELS

FXR EA
 FXRS-SP EG
 FXLR EL
 FXRS-CON EM

SOFTAIL MODELS

FLSTC BJ
 FXSTC BK
 FXSTS BL
 FLSTF BM
 FLSTN BN

DYNA MODELS

FXDL GD
 FXDWG GE
 FXDS-CON GG

SWITCHES & CIRCUIT BREAKERS - FLT

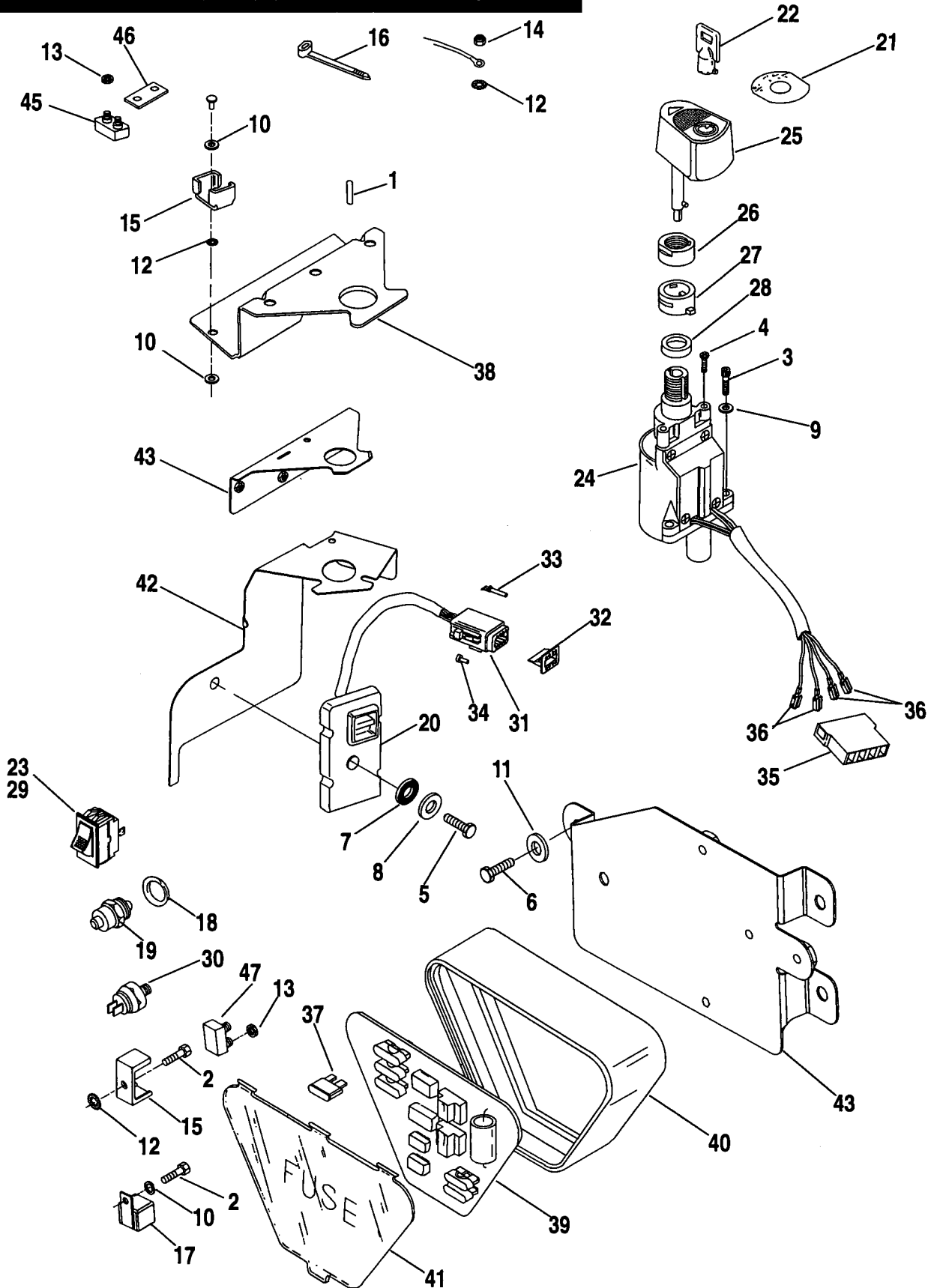

INDEX NO.	PART NO.	DESCRIPTION	FLT MODELS	FXR MODELS	SOFTAIL MODELS	DYNA MODELS
1	608	ROLL PIN	93*-ALL	--	--	--
2	2523	SCREW (2; 3 - 1993 DM/P)	93*-ALL	--	--	--
3	2647B	SCREW (2)	93*-ALL	--	--	--
4	2734	SCREW (2)	93*-DJ/P	--	--	--
5	3993	BOLT	94*-FD	--	--	--
6	3767B	SCREW (3)	94*-FD	--	--	--
7	6035	WASHER (rubber)	94*-FD	--	--	--
8	6036	WASHER	94*-FD	--	--	--
9	6150W	WASHER (2)	93*-ALL	--	--	--
10	6198	WASHER (5)	93-ALL	--	--	--
	7102	LOCKWASHER (2)	94*-FD	--	--	--
11	6703	WASHER (3)	94*-FD	--	--	--
12	7229W	LOCKWASHER (7-1993; 2)	93*-ALL	--	--	--
13	7629	NUT (12)	93-ALL	--	--	--
14	7686	LOCKNUT	93-ALL	--	--	--
			94*-DJ/M/P			
15	9952	CLIP (6)	93-ALL	--	--	--
16	10039	CABLE STRAP	93*-DM/P	--	--	--
	10065	CABLE STRAP	93*-DM/P	--	--	--
17	31504-91A	RELAY (2-L93 & later DJ/M/P,FD)	93*-ALL	--	--	--
	31506-79B	STARTER RELAY	E93-ALL	--	--	--
18	33043-80	WASHER, neutral indicator switch	93*-ALL	--	--	--
19	33900-59C	SWITCH, neutral indicator	93*-ALL	--	--	--
	53560-93	LOCK SET, complete vehicle	93-FA	--	--	--
	53571-94	LOCK SET, complete vehicle	94*-FD	--	--	--
	53574-93	LOCK SET, complete vehicle	93*-DJ/P	--	--	--
	53575-93	LOCK SET, complete vehicle	93*-DM	--	--	--
20	68537-89D	TURN SIGNAL CANCELLER	93-ALL	--	--	--
	68570-94A	TURN SIGNAL CANCELLER	94*-ALL	--	--	--
21	71426-93A	DECAL, ignition switch	93*-DM;FA	--	--	--
	71427-93	DECAL, ignition switch	93*-DJ/P	--	--	--
22	71452-91A	KEY (specify 4 digit code)	93*-ALL	--	--	--
23	71505-89	SWITCH, passing lamps	93*-DJ/P	--	--	--
24	71526-93A	HOUSING, ignition switch	93-ALL	--	--	--
			94*-DJ/M/P			--
25	71536-93	KNOB, ignition switch	93-ALL	--	--	--
			94*-DJ/M/P			
26	71543-93	NUT, ignition switch	93-ALL	--	--	--
			94*-DJ/M/P			
27	71544-93	COLLAR, ignition switch	93-ALL	--	--	--
			94*-DJ/M/P			
28	71545-93	SPACER, ignition switch	93-ALL	--	--	--
			94*-DJ/M/P			
29	71535-94	SWITCH, accessory	94*-DJ/P	--	--	--
30	72023-51A	STOPLIGHT SWITCH, rear	93*-ALL	--	--	--
31	72138-94	PLUG, 8-way socket	94*-ALL	--	--	--
32	72158-94	SOCKET LOCK, sec. 8-way	94*-DJ/P	--	--	--
33	72191-94	TERMINAL, socket (7)	94*-DJ/P	--	--	--
34	72195-94	SEAL PIN	94*-DJ/P	--	--	--

FLT MODELS

FLHTC
FLTC-U
FLHTC-U
FLHS
FLHR

DJ
DM
DP
FA
FD

FXR MODELS

FXR
FXRS-SP
FXLR
FXRS-CON
EA
EG
EL
EM

SOFTAIL MODELS

FLSTC
FXSTC
FXSTS
FLSTF
FLSTN
BJ
BK
BL
BM
BN

DYNA MODELS

FXDL
FXDWG
FXDS-CON
GD
GE
GG

SWITCHES & CIRCUIT BREAKERS - FLT

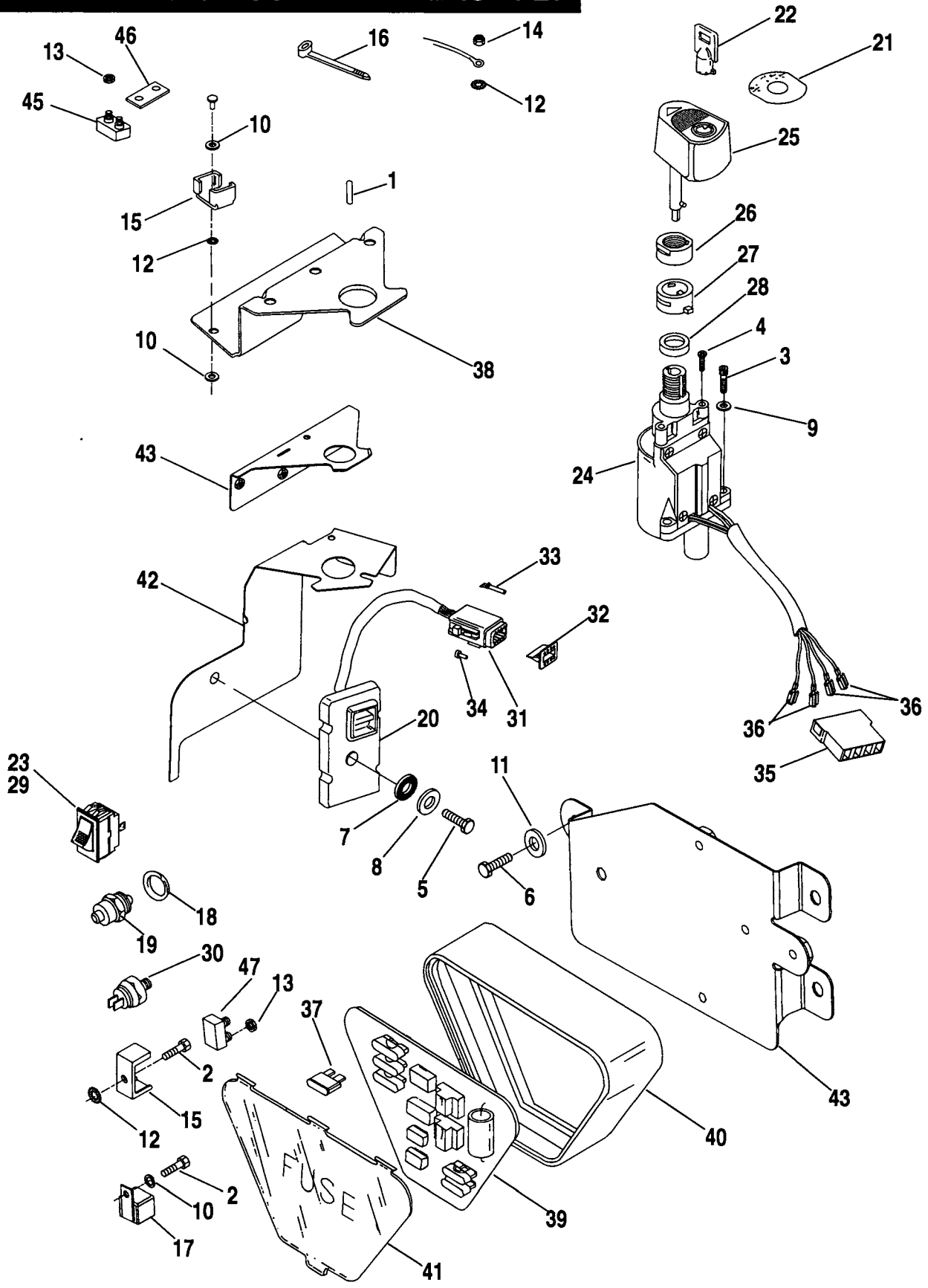

INDEX NO.	PART NO.	DESCRIPTION	FLT MODELS	FXR MODELS	SOFTAIL MODELS	DYNA MODELS
35	72206-94	CONNECTOR, receptacle, 4-way	94*-ALL	--	--	--
36	72207-94	TERMINAL, female, #14 ga., ign. sw. (4)	94*-ALL	--	--	--
37	72300-89	FUSE, 1 amp	93*-DM/P	--	--	--
	72301-89	FUSE, 3 amp	93*-DM/P	--	--	--
	72302-89	FUSE, 5 amp	93*-DM/P	--	--	--
38	72306-88	MOUNTING BRACKET	93-ALL	--	--	--
39	72316-93	FUSE BOARD	93*-DM/P	--	--	--
40	72321-93	FUSE BOX	93*-DM/P	--	--	--
41	72322-93	COVER, fuse box	93*-DM/P	--	--	--
42	72332-94	MOUNTING BRACKET	94*-FD	--	--	--
43	72334-94	MOUNTING BRACKET	94*-DJ/P	--	--	--
44	72343-94	FUSEBOARD ASM.	94*-FD	--	--	--
45	74589-73	CIRCUIT BREAKER, 15 amp (5; 4 - FA)	93-ALL	--	--	--
	74590-93	CIRCUIT BREAKER, 10 amp	93-FA	--	--	--
46	74598-73	CONNECTOR BAR	93-ALL	--	--	--
47	74599-77B	CIRCUIT BREAKER, 30 amp - battery	93-ALL	--	--	--
	74600-94	CIRCUIT BREAKER, 50 amp	94*-ALL	--	--	--
		H-D INTERNATIONAL ONLY				
	67858-89	SWITCH, parking & passing lamps (HDI only)	93-DM,FA; 93*-DM	--	--	--
	71512-89	SWITCH, parking lamps (HDI only)	93*-DJ/P	--	--	--

FLT MODELS

FLHTC DJ
 FLTC-U DM
 FLHTC-U DP
 FLHS FA
 FLHR FD

FXR MODELS

FXR EA
 FXRS-SP EG
 FXLR EL
 FXRS-CON EM

SOFTAIL MODELS

FLSTC BJ
 FXSTC BK
 FXSTS BL
 FLSTF BM
 FLSTN BN

DYNA MODELS

FXDL GD
 FXDWG GE
 FXDS-CON GG

SWITCHES & CIRCUIT BREAKERS - FXR

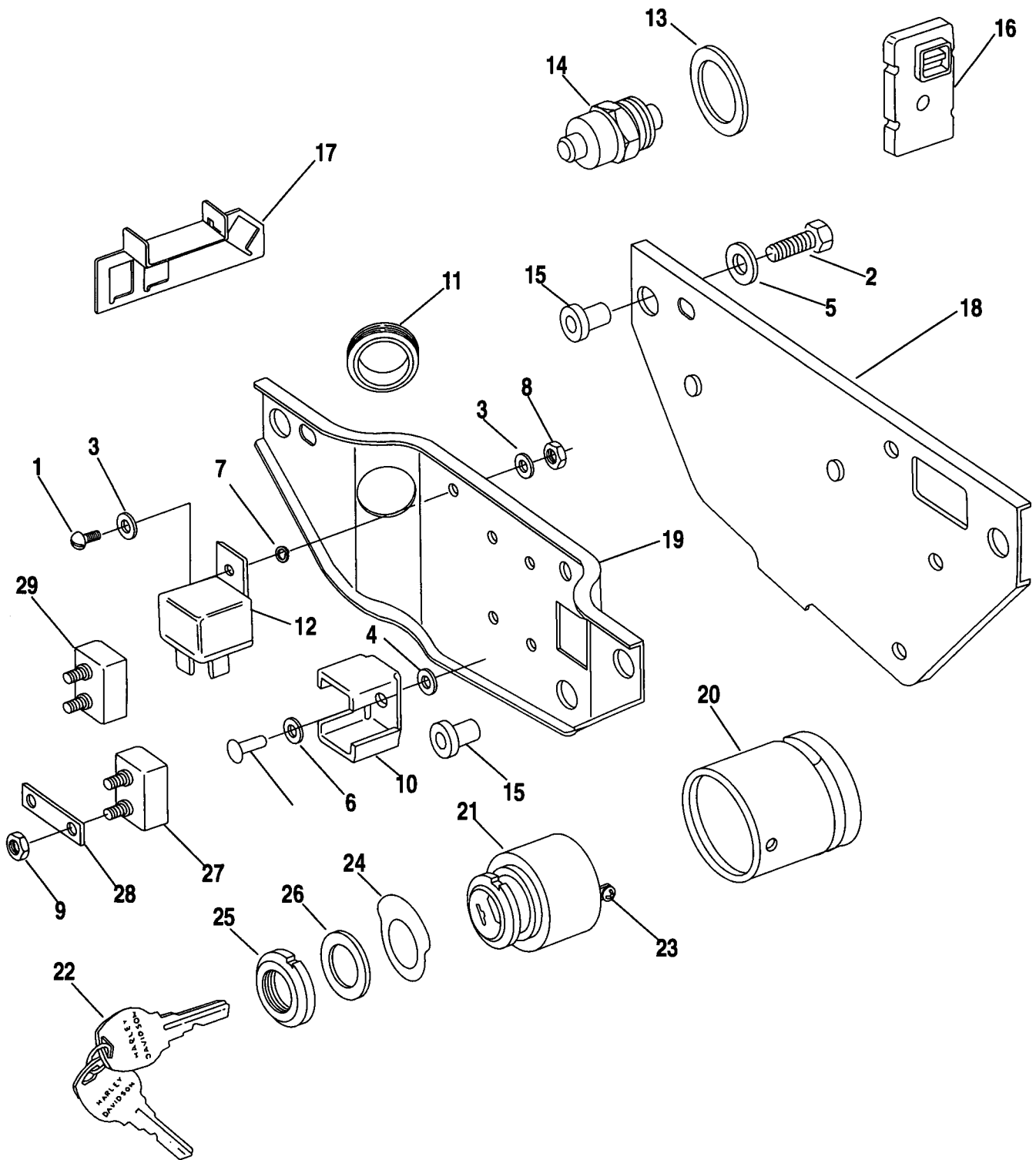

INDEX NO.	PART NO.	DESCRIPTION	FLT MODELS	FXR MODELS	SOFTAIL MODELS	DYNA MODELS
1	909	SCREW	--	93*-ALL	--	--
2	3787	BOLT (6)	--	93*-ALL	--	--
3	6150W	WASHER (2)	--	93*-ALL	--	--
4	6198	WASHER (8)	--	93*-ALL	--	--
5	6703	WASHER (6)	--	93*-ALL	--	--
6	7229W	LOCKWASHER (4)	--	93*-ALL	--	--
7	7230	WASHER	--	93*-ALL	--	--
8	7620W	NUT	--	93*-ALL	--	--
9	7629	NUT (8)	--	93*-ALL	--	--
10	9952	CLIP, circuit breakers (4)	--	93*-ALL	--	--
11	11440	GROMMET	--	93*-ALL	--	--
12	31504-91A	STARTER RELAY	--	L93*-ALL	--	--
	31506-79B	STARTER RELAY	--	E93-ALL	--	--
13	33043-80	WASHER, neutral indicator switch	--	93*-ALL	--	--
14	33900-59C	SWITCH, neutral indicator	--	93*-ALL	--	--
15	64511-63	WELL NUT (6)	--	93*-ALL	--	--
16	68537-89D	TURN SIGNAL CANCELLER	--	93*-ALL	--	--
17	70199-92	BRACKET, connectors	--	93*-EL	--	--
18	70970-91	IGNITION PANEL	--	93*-ALL	--	--
19	70979-86	ELECTRICAL PANEL	--	93*-ALL	--	--
20	71424-83	BOOT, ignition switch	--	93*-ALL	--	--
21	71425-77	IGNITION SWITCH	--	93-ALL	--	--
	71441-94	IGNITION SWITCH ASM.	--	94*-ALL	--	--
22	71451-78	KEYSET, ignition switch (Specify key no.)	--	93-ALL	--	--
	71451-94	KEYSET, ignition switch (Specify key code)	--	94*-ALL	--	--
23	71518-80	SCREW w/ washer (3)	--	93-ALL	--	--
24	71550-75	LABEL, ignition switch	--	93-ALL	--	--
25	71552-75	FACE NUT, ignition switch	--	93-ALL	--	--
	71552-94	FACE NUT, ignition switch	--	94*-ALL	--	--
26	71554-75	WASHER, ignition switch	--	93*-ALL	--	--
27	74589-73	CIRCUIT BREAKER, 15 amp (3)	--	93*-ALL	--	--
28	74598-73	CONNECTOR BAR, circuit breaker	--	93*-ALL	--	--
29	74599-77B	CIRCUIT BREAKER, 30 amp - battery	--	93*-ALL	--	--

FLT MODELS

FLHTC DJ
 FLTC-U DM
 FLHTC-U DP
 FLHS FA
 FLHR FD

FXR MODELS

FXR EA
 FXRS-SP EG
 FXLR EL
 FXRS-CON EM

SOFTAIL MODELS

FLSTC BJ
 FXSTC BK
 FXSTS BL
 FLSTF BM
 FLSTN BN

DYNA MODELS

FXDL GD
 FXDWG GE
 FXDS-CON GG

SWITCHES & CIRCUIT BREAKERS - SOFTAIL

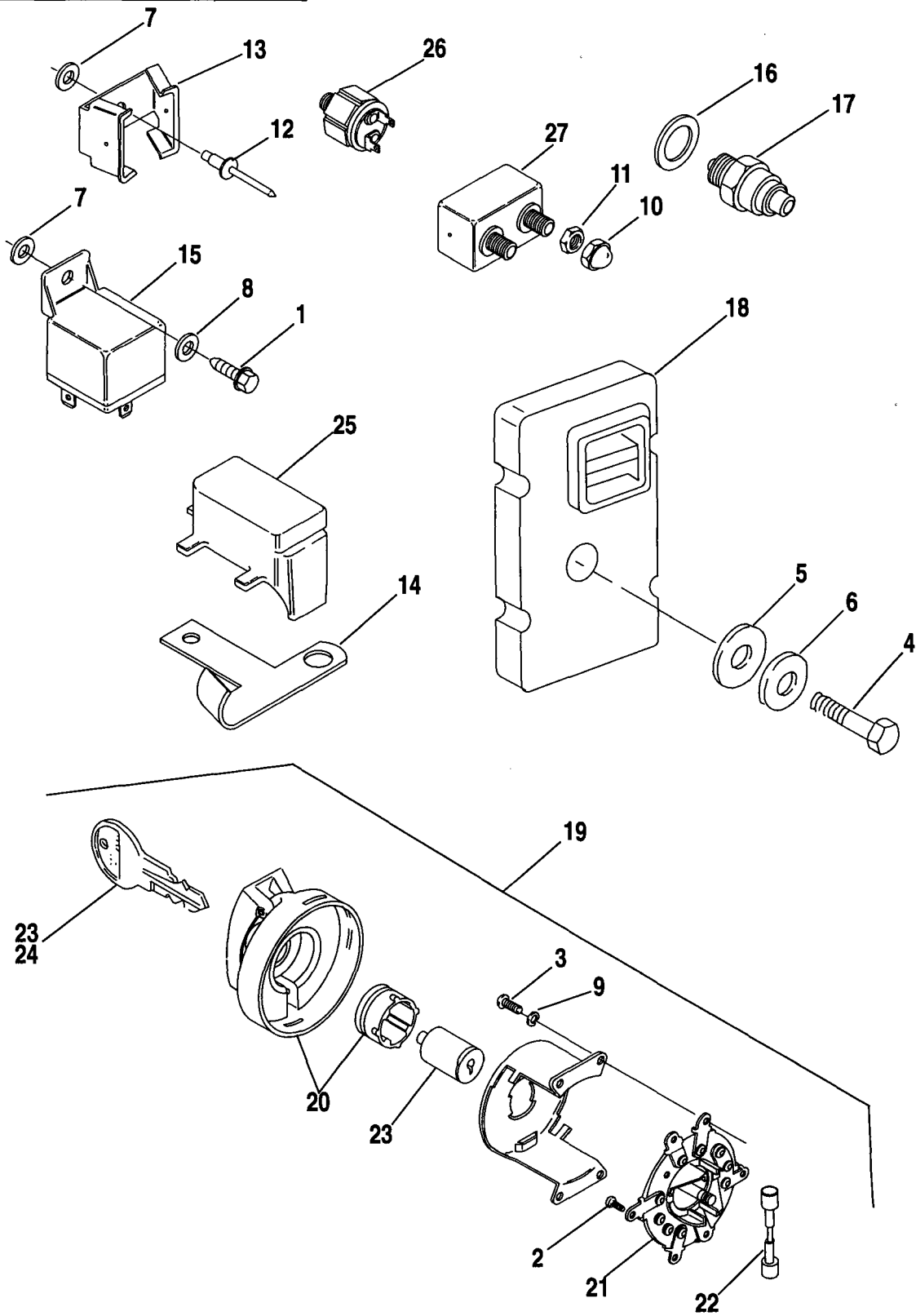

INDEX NO.	PART NO.	DESCRIPTION	FLT MODELS	FXR MODELS	SOFTAIL MODELS	DYNA MODELS
1	2567	SCREW, sems	--	--	94*-ALL	--
2	2574WA	SCREW (6)	--	--	93*-ALL	--
3	2594A	SCREW (4)	--	--	93*-ALL	--
4	3993	SCREW	--	--	93*-ALL	--
5	6035	WASHER (rubber)	--	--	93*-ALL	--
6	6036	WASHER	--	--	93*-ALL	--
7	6047	WASHER (3; 2-1994 & later)	--	--	93*-ALL	--
8	6199	WASHER	--	--	93-ALL	--
9	7015	LOCKWASHER (4)	--	--	93*-ALL	--
10	7602	CAP NUT (4)	--	--	93*-ALL	--
11	7629	NUT (8)	--	--	93*-ALL	--
12	8483	RIVET, circuit breakers (3)	--	--	93*-ALL	--
13	9952	CLIP, circuit breaker (4)	--	--	93*-ALL	--
14	10134	CLIP	--	--	93*-ALL	--
15	31504-91A	STARTER RELAY	--	--	L93*-ALL	--
	31506-79B	STARTER RELAY	--	--	E93-ALL	--
16	33043-80	WASHER, neutral indicator switch	--	--	93*-ALL	--
17	33900-59C	SWITCH, neutral indicator	--	--	93*-ALL	--
18	68537-89D	TURN SIGNAL CANCELLER	--	--	93*-ALL	--
19	71501-73A	IGNITION SWITCH	--	--	93-ALL	--
	71501-94	IGNITION SWITCH	--	--	94*-ALL	--
20	71506-84	SWITCH COVER	--	--	93-ALL	--
	71506-94	SWITCH COVER	--	--	94*-ALL	--
21	71541-84	PLATE, switch mounting	--	--	93*-ALL	--
22	71560-84	CONTACT ROLLER	--	--	93*-ALL	--
23	71580-84	SWITCH LOCK & KEY	--	--	93*-ALL	--
24	71583-85	KEYSET, ignition switch (Specify key #.)	--	--	93*-ALL	--
25	71600-93	SPLASH COVER	--	--	93*-ALL	--
26	72023-51A	STOPLAMP SWITCH, rear	--	--	93*-ALL	--
27	74589-73	CIRCUIT BREAKER, 15 amp (3)	--	--	93*-ALL	--
	74599-77B	CIRCUIT BREAKER, 30 amp - battery	--	--	93*-ALL	--

FLT MODELS

FLHTC DJ
 FLTC-U DM
 FLHTC-U DP
 FLHS FA
 FLHR FD

FXR MODELS

FXR EA
 FXRS-SP EG
 FXLR EL
 FXRS-CON EM

SOFTAIL MODELS

FLSTC BJ
 FXSTC BK
 FXSTS BL
 FLSTF BM
 FLSTN BN

DYNA MODELS

FXDL GD
 FXDWG GE
 FXDS-CON GG

SWITCHES & CIRCUIT BREAKERS - DYNA

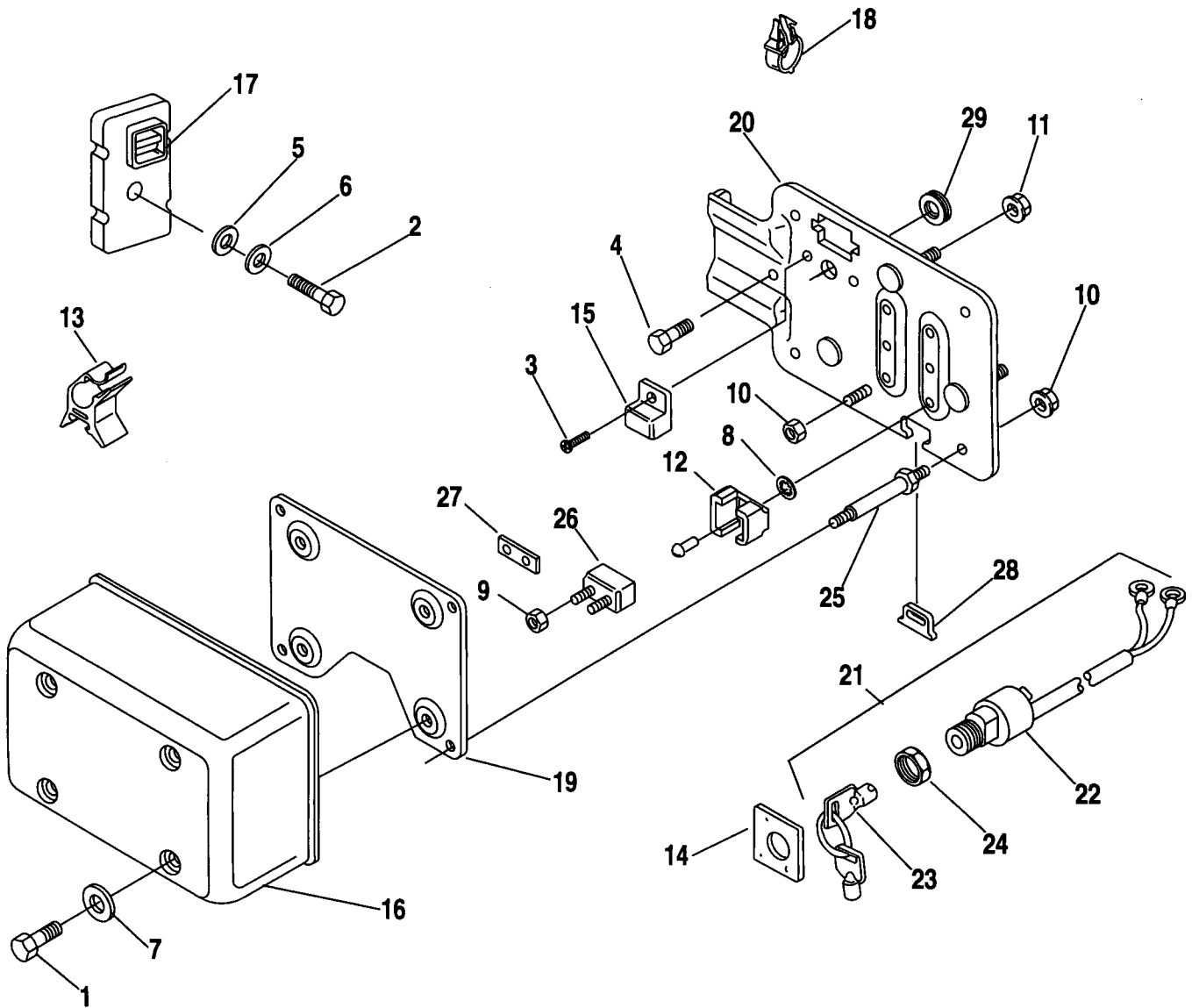

INDEX NO.	PART NO.	DESCRIPTION	FLT MODELS	FXR MODELS	SOFTAIL MODELS	DYNA MODELS
1	3444A	SCREW (4)	--	--	--	93*-ALL
2	3993	SCREW	--	--	--	93*-ALL
3	4091	SCREW	--	--	--	93*-ALL
4	4384	SCREW	--	--	--	93*-ALL
5	6035	WASHER (rubber)	--	--	--	93*-ALL
6	6036	WASHER	--	--	--	93*-ALL
7	6099	WASHER (4)	--	--	--	93*-ALL
8	7229W	LOCKWASHER (4)	--	--	--	93*-ALL
9	7629	NUT, keps (10)	--	--	--	93*-ALL
10	7716	NUT (9)	--	--	--	93*-ALL
11	7796	NUT (2)	--	--	--	93*-ALL
12	9952	CLIP (4)	--	--	--	93*-ALL
13	10130	CLIP, backbone, ign. sw.	--	--	--	94*-ALL
14	14117-94	DECAL, ignition switch	--	--	--	93*-GD/G
15	31504-91A	RELAY, starter	--	--	--	L94*-ALL
15	31506-79B	RELAY, starter	--	--	--	E93-ALL
16	66333-90	COVER, electrical panel (chrome)	--	--	--	93*-ALL
17	68537-89D	TURN SIGNAL CANCELLER	--	--	--	93*-ALL
18	70347-84	RETAINER, wire	--	--	--	93*-ALL
19	70984-90A	BRACKET, ignition module	--	--	--	93*-GD/G
20	70987-90A	ELECTRICAL PANEL	--	--	--	93*-ALL
21	71421-90	LOCK SET (fork & ignition w/ key)	--	--	--	93-GD
	71421-94	LOCK SET (fork & ignition w/ key)	--	--	--	94*-GD/G
22	71428-90B	IGNITION SWITCH	--	--	--	93*-GD/G
23	71452-91A	KEY (specify 4 digit key no.)	--	--	--	93*-ALL
24	71555-90	FACE NUT	--	--	--	93*-GD/G
25	72342-90	STAND OFF (4)	--	--	--	93*-ALL
26	74589-73	CIRCUIT BREAKER, 15 amp (3)	--	--	--	93*-ALL
	74599-77B	CIRCUIT BREAKER, 30 amp - battery	--	--	--	93*-ALL
27	74598-73	CONNECTOR BAR (2)	--	--	--	93*-ALL
28	90474-90	GROMMET	--	--	--	93*-ALL
29	90483-85	GROMMET	--	--	--	93*-ALL
H-D INTERNATIONAL ONLY						
14	14121-90	DECAL, ignition switch (HDI only)	--	--	--	93-GD
	14121-94	DECAL, ignition switch (HDI only)	--	--	--	94*-GD/G

FLT MODELS
 FLHTC DJ
 FLTC-U DM
 FLHTC-U DP
 FLHS FA
 FLHR FD

FXR MODELS
 FXR EA
 FXRS-SP EG
 FXLR EL
 FXRS-CON EM

SOFTAIL MODELS
 FLSTC BJ
 FXSTC BK
 FXSTS BL
 FLSTF BM
 FLSTN BN

DYNA MODELS
 FXDL GD
 FXDWG GE
 FXDS-CON GG

SADDLEBAGS - FLT

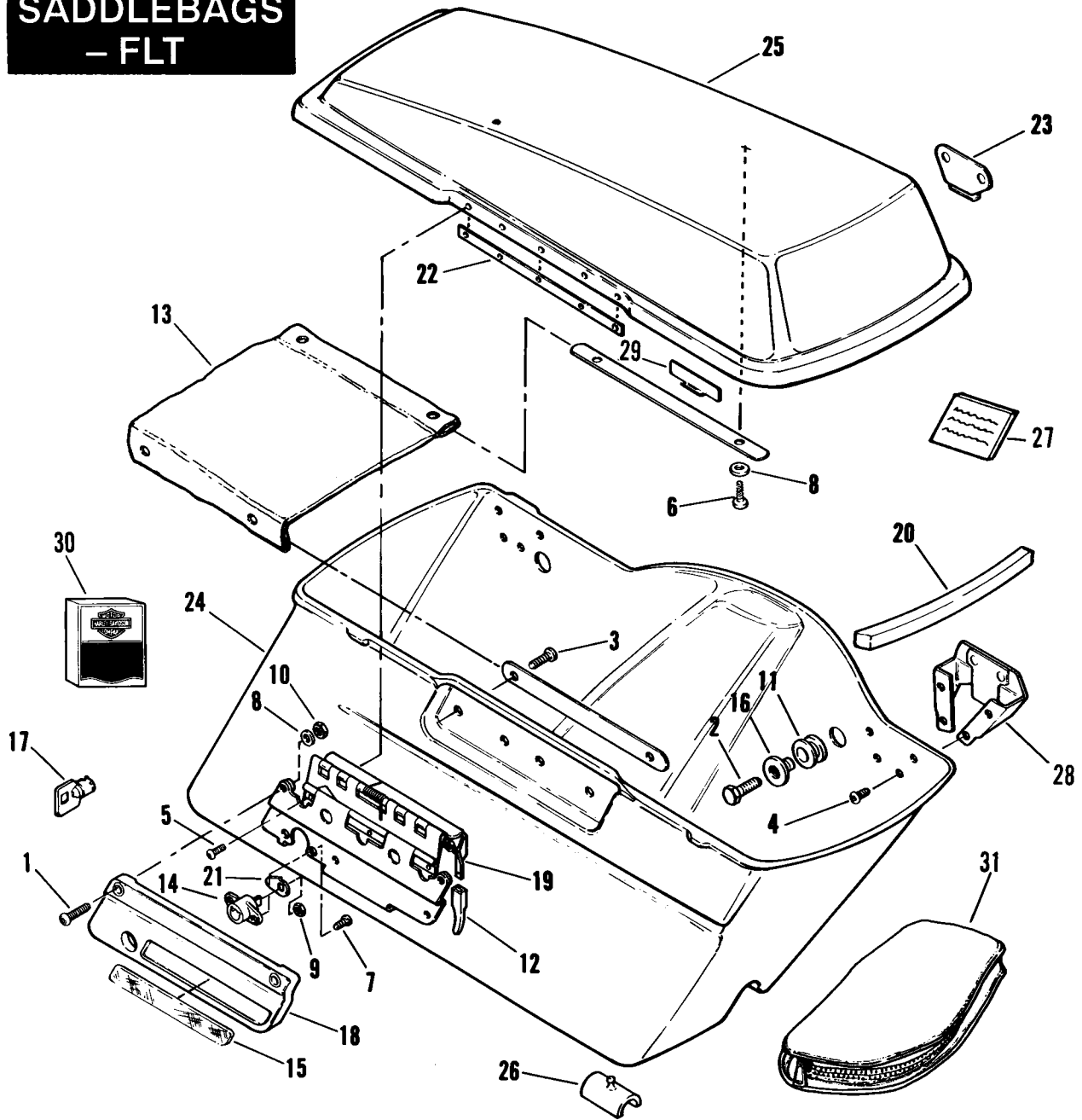

INDEX NO.	PART NO.	DESCRIPTION	FLT MODELS	FXR MODELS	SOFTAIL MODELS	DYNA MODELS
1	2524	SCREW (4)	93*-ALL	--	--	--
2	2551W	SCREW (4)	93*-ALL	--	--	--
3	3592	SCREW (4)	93*-ALL	--	--	--
4	3593	SCREW (16)	93*-ALL	--	--	--
5	3595	SCREW (10)	93*-ALL	--	--	--
6	3596	SCREW (4)	93*-ALL	--	--	--
7	3656	SCREW (4)	93*-ALL	--	--	--
8	6196	WASHER (8)	93*-ALL	--	--	--
9	7586	NUT (2)	93*-ALL	--	--	--
10	7608	NUT (4)	93*-ALL	--	--	--
11	11464	GROMMET (4)	93*-ALL	--	--	--
12	53482-93	RUB BAR, left (plastic)(2)	93*-ALL	--	--	--
	53483-93	RUB BAR, right (plastic)(2)	93*-ALL	--	--	--
	53560-93	LOCK SET, complete vehicle	93-FA	--	--	--
	53571-94	LOCK SET, complete vehicle	94*-FD	--	--	--
	53574-93	LOCK SET, complete vehicle	93*-DJ/P	--	--	--
	53575-93	LOCK SET, complete vehicle	93*-DM	--	--	--
13	53567-93	CHECK STRAP	93*-ALL	--	--	--
14	53585-93	LOCK (2)	93*-ALL	--	--	--
15	59287-92	REFLECTOR, right (red)	93*-ALL	--	--	--
	59288-92	REFLECTOR, left (red)	93*-ALL	--	--	--
16	67002-93	SPACER (4)	93*-ALL	--	--	--
17	71452-91A	KEY (specify 4 digit code)	93*-ALL	--	--	--
18	90601-93	FACE PLATE, right	93*-ALL	--	--	--
	90603-93	FACE PLATE, left	93*-ALL	--	--	--
19	90664-93	LATCH, left	93*-ALL	--	--	--
	90665-93	LATCH, right	93*-ALL	--	--	--
20	90675-93	GASKET, cover (2)	93*-ALL	--	--	--
21	90682-93	CAM HOOK (2)	93*-ALL	--	--	--
22	90700-93	BACKING PLATE	93*-ALL	--	--	--
23	90962-93	WEAR PLATE (4)	93*-ALL	--	--	--
24	90752-93	SADDLEBAG BOTTOM, right (prime)	93*-ALL	--	--	--
	90753-93	SADDLEBAG BOTTOM, left (prime)	93*-ALL	--	--	--
25	90756-93	SADDLEBAG COVER, right (prime)	93*-ALL	--	--	--
	90757-93	SADDLEBAG COVER, left (prime)	93*-ALL	--	--	--
26	90764-93	CUSHION (4)	93*-ALL	--	--	--
27	90820-93	LABEL, load limits	93*-ALL	--	--	--
28	90958-93	MOUNTING BRACKET (4)	93*-ALL	--	--	--
29	90972-93	WEAR TAB (4)	93*-ALL	--	--	--
30	91841-93	LINER (2)	93*-DM/P	--	--	--
31	94435-82C	TOOL KIT	93*-DJ/M/P	--	--	--
SADDLEBAG LATCH FOR SIDECAR UNIT						
	53488-93	WEAR PAD	93*-ALL	--	--	--
19	90670-93	LATCH, right	93*-ALL	--	--	--
H-D INTERNATIONAL ONLY						
15	59289-92	REFLECTOR, right (amber)(HDI only)	93*-ALL	--	--	--
	59290-92	REFLECTOR, left (amber)(HDI only)	93*-ALL	--	--	--

FLT MODELS
 FLHTC
 FLTC-U
 FLHTC-U
 FLHS
 FLHR

FXR MODELS
 DJ
 DM
 DP
 FA
 FD
 FXR
 FXRS-SP
 FXLR
 FXRS-CON
 EA
 EG
 EL
 EM

SOFTAIL MODELS
 FLSTC
 FXSTC
 FXSTS
 FLSTF
 FLSTN
 BJ
 BK
 BL
 BM
 BN

DYNA MODELS
 FXDL
 FXDWG
 FXDS-CON
 GD
 GE
 GG

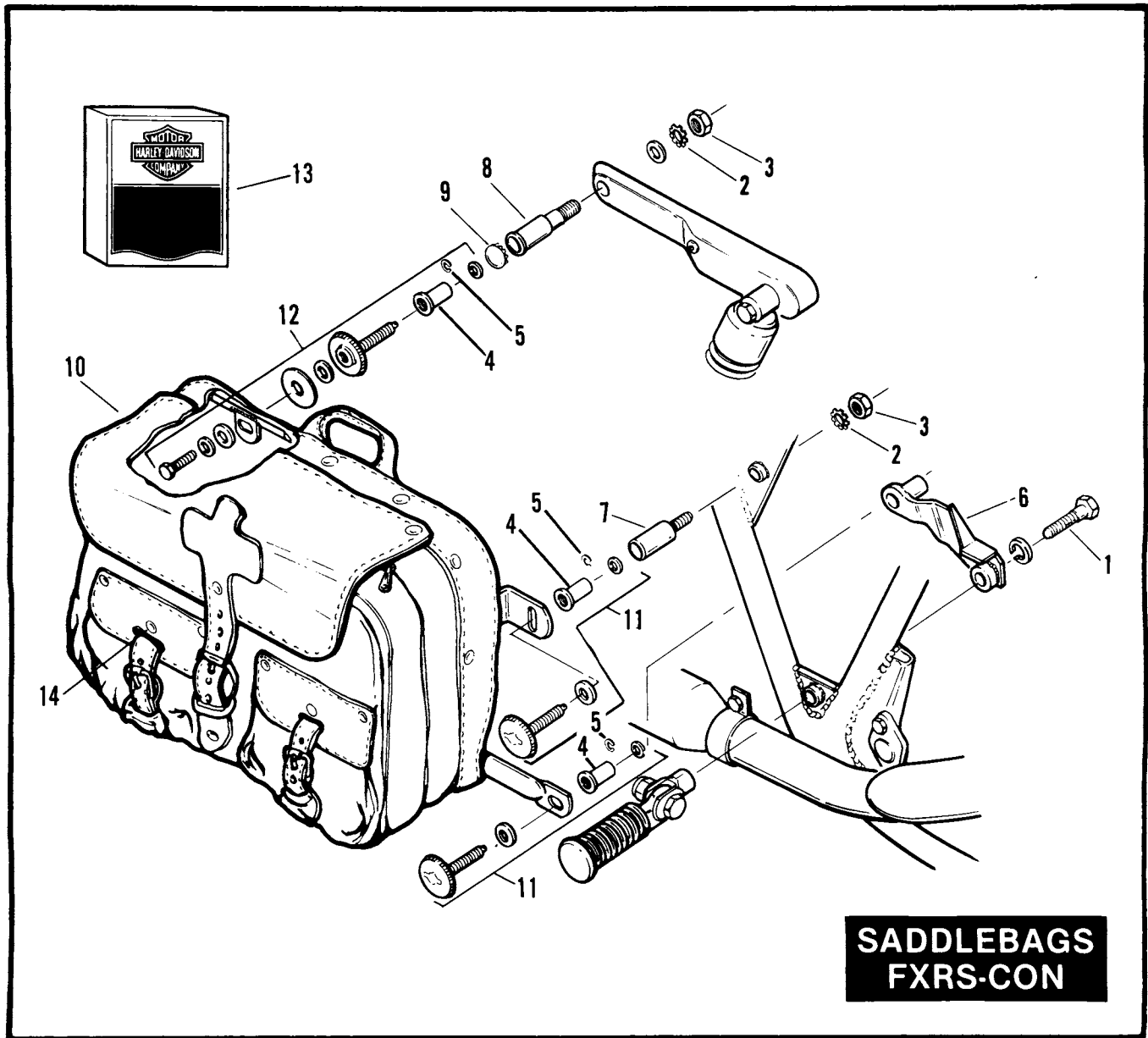

**SADDLEBAGS
FXRS-CON**

INDEX NO.	PART NO.	DESCRIPTION	FLT MODELS	FXR MODELS	SOFTAIL MODELS	DYNA MODELS
1	4081	BOLT (2)	--	93*-EM	--	--
2	7145W	LOCKWASHER (4)	--	93*-EM	--	--
3	7643W	NUT (4)	--	93*-EM	--	--
4	8096	WELL NUT (6)	--	93*-EM	--	--
5	11252	SNAP RING (6)	--	93*-EM	--	--
6	90350-89	MOUNTING BRACKET, lower - right	--	93*-EM	--	--
	90351-89	MOUNTING BRACKET, lower - right	--	93*-EM	--	--
7	90359-89	WELL NUT RECEPTACLE, - upper - front (2)	--	93*-EM	--	--
8	90360-89	WELL NUT STUD (2)	--	93*-EM	--	--
9	90357-89	HOLE PLUG (chrome) (2)	--	93*-EM	--	--
10	90702-89	SADDLEBAG, left	--	93*-EM	--	--
	90703-89	SADDLEBAG, right	--	93*-EM	--	--
11	90712-89	ATTACHMENT KIT, front (2)	--	93*-EM	--	--
12	90714-89	ATTACHMENT KIT, rear	--	93*-EM	--	--
13	90706-89	RAINCOAT, left	--	93*-EM	--	--
	90708-89	RAINCOAT, right	--	93*-EM	--	--
14	90731-89	RIVET REPAIR KIT	--	93*-EM	--	--

FLT MODELS

FLHTC DJ
 FLTC-U DM
 FLHTC-U DP
 FLHS FA
 FLHR FD

FXR MODELS

FXR EA
 FXRS-SP EG
 FXLR EL
 FXRS-CON EM

SOFTAIL MODELS

FLSTC BJ
 FXSTC BK
 FXSTS BL
 FLSTF BM
 FLSTN BN

DYNA MODELS

FXDL GD
 FXDWG GE
 FXDS-CON GG

SADDLEBAGS - FLSTC & FLSTN

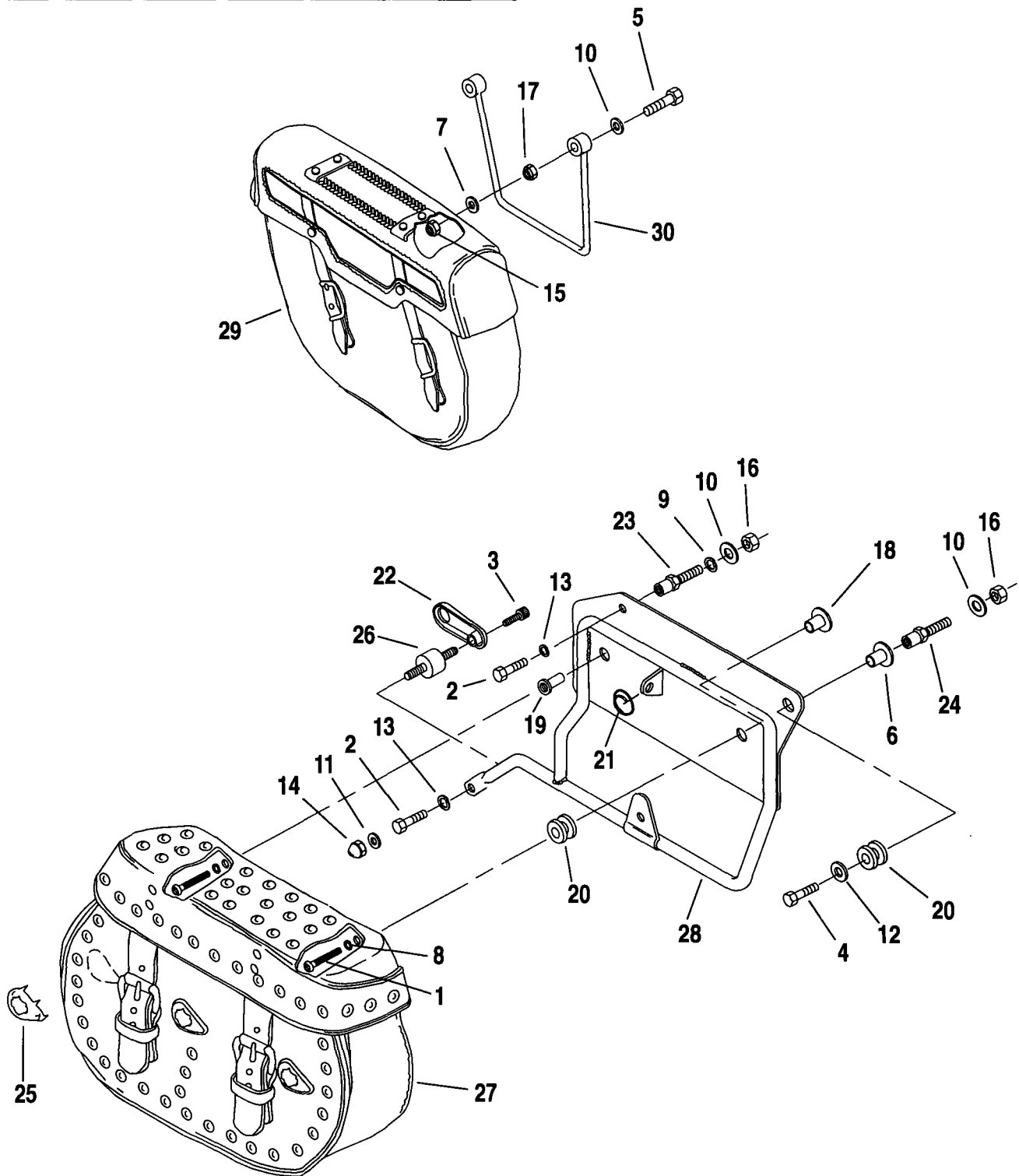

INDEX NO.	PART NO.	DESCRIPTION	FLT MODELS	FXR MODELS	SOFTAIL MODELS	DYNA MODELS
1	2602	BOLT (6)	--	--	93*-BJ	--
2	2882W	BOLT (6)	--	--	93-BJ	--
3	3549A	SCREW (2)	--	--	94*-BJ	--
4	4017	SCREW (4)	--	--	94*-BJ	--
5	4719W	BOLT (4)	--	--	93*-BN	--
6	5787	T-SPACER (4)	--	--	94*-BJ	--
7	6019	WASHER (4)	--	--	93*-BN	--
8	6235	WASHER (4; 6-1994 & later)	--	--	93*-BJ	--
9	6379W	WASHER (4)	--	--	93-BJ	--
10	6701	WASHER (4)	--	--	93*-BJ/N	--
11	6702	WASHER (2)	--	--	94*-BJ	--
12	6788	WASHER (4)	--	--	94*-BJ	--
13	7041	LOCKWASHER (6)	--	--	93-BJ	--
14	7507	ACORN NUT (2)	--	--	94*-BJ	--
15	7601	LOCKNUT (4)	--	--	93*-BN	--
16	7778	LOCKNUT (4)	--	--	93*-BJ	--
17	7783	JAM NUT (4)	--	--	93*-BN	--
18	7868	T-SPACER (6)	--	--	94*-BJ	--
19	8099	WELL NUT (6)	--	--	93-BJ	--
20	11473	GROMMET (10)	--	--	94*-BJ	--
21	51923-86	COTTER CIRCLE (2)	--	--	93*-BJ	--
22	90346-90	SUPPORT, lower - front (2)	--	--	93-BJ	--
	90346-94	SUPPORT, lower - front (2)	--	--	94*-BJ	--
23	90361-90	SUPPORT, upper, (4)	--	--	93-BJ	--
24	90361-94	SUPPORT, upper (4)	--	--	94*-BJ	--
25	90470-90	ORNAMENT, teardrop-right (3)	--	--	93*-BJ	--
	90471-90	ORNAMENT, teardrop-left (3)	--	--	93*-BJ	--
26	90473-94	ISOLATOR (2)	--	--	94*-BJ	--
27	90476-93	SADDLEBAG, left	--	--	93*-BJ	--
	90477-93	SADDLEBAG, right	--	--	93*-BJ	--
28	90785-90	SUPPORT, right	--	--	93-BJ	--
	90785-94	SUPPORT, right	--	--	94*-BJ	--
	90787-90	SUPPORT, left	--	--	93-BJ	--
	90787-94	SUPPORT, left	--	--	94*-BJ	--
29	90804-92	SADDLEBAG, right	--	--	93-BN	--
	90804-94	SADDLEBAG, right	--	--	94*-BN	--
	90806-92	SADDLEBAG, left	--	--	93-BN	--
	90806-94	SADDLEBAG, left	--	--	94*-BN	--
30	91791-87	SADDLEBAG SUPPORT, right	--	--	93*-BN	--
	91792-87	SADDLEBAG SUPPORT, left	--	--	93*-BN	--

FLT MODELS

FLHTC DJ
 FLTC-U DM
 FLHTC-U DP
 FLHS FA
 FLHR FD

FXR MODELS

FXR EA
 FXRS-SP EG
 FXLR EL
 FXRS-CON EM

SOFTAIL MODELS

FLSTC BJ
 FXSTC BK
 FXSTS BL
 FLSTF BM
 FLSTN BN

DYNA MODELS

FXDL GD
 FXDWG GE
 FXDS-CON GG

SADDLEBAGS - FXDS-CON

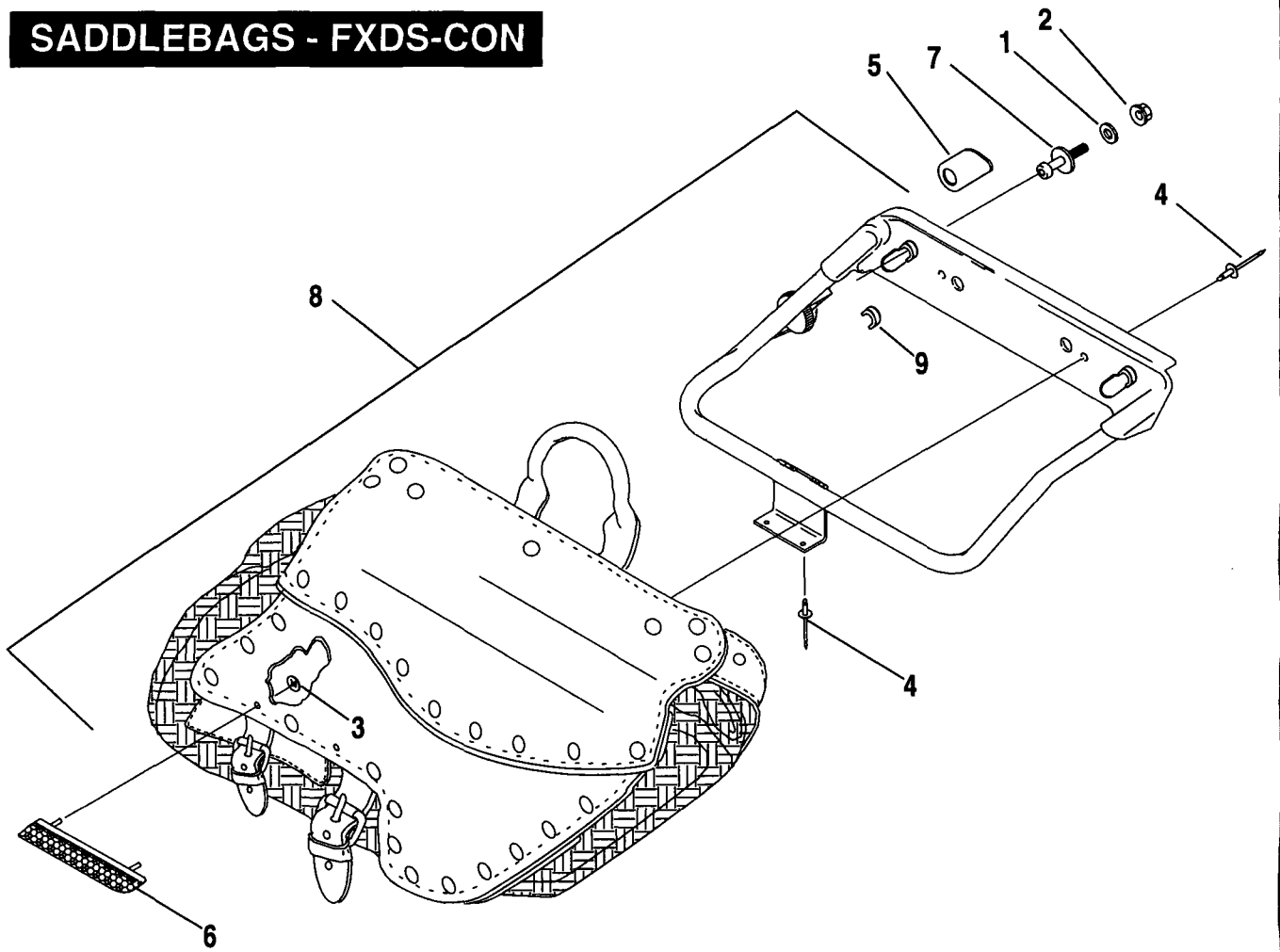

INDEX NO.	PART NO.	DESCRIPTION	FLT MODELS	FXR MODELS	SOFTAIL MODELS	DYNA MODELS
1	6379W	WASHER (4)	--	--	--	94*-GG
2	7601	LOCKNUT, flange	--	--	--	94*-GG
3	8126	PUSH NUT (4)	--	--	--	94*-GG
4	8540	RIVET (8)	--	--	--	94*-GG
5	59279-94	PROTECTOR, fender - right	--	--	--	94*-GG
	59284-94	PROTECTOR, fender - left	--	--	--	94*-GG
6	59293-94	REFLECTOR, right (red)	--	--	--	94*-GG
	59294-94	REFLECTOR, left (red)	--	--	--	94*-GG
7	90635-94	STUD (4)	--	--	--	94*-GG
8	90817-94	SADDLEBAG ASM. - left	--	--	--	94*-GG
	90818-94	SADDLEBAG ASM. - right	--	--	--	94*-GG
9	90823-94	BUSHING (4)	--	--	--	94*-GG
H-D INTERNATIONAL ONLY						
6	59295-94	REFLECTOR, right (amber)	--	--	--	94*-GG
	59296-94	REFLECTOR, right (amber)	--	--	--	94*-GG

FLT MODELS
 FLHTC DJ
 FLTC-U DM
 FLHTC-U DP
 FLHS FA
 FLHR FD

FXR MODELS
 FXR EA
 FXRS-SP EG
 FXLR EL
 FXRS-CON EM

SOFTAIL MODELS
 FLSTC BJ
 FXSTC BK
 FXSTS BL
 FLSTF BM
 FLSTN BN

DYNA MODELS
 FXDL GD
 FXDWG GE
 FXDS-CON GG

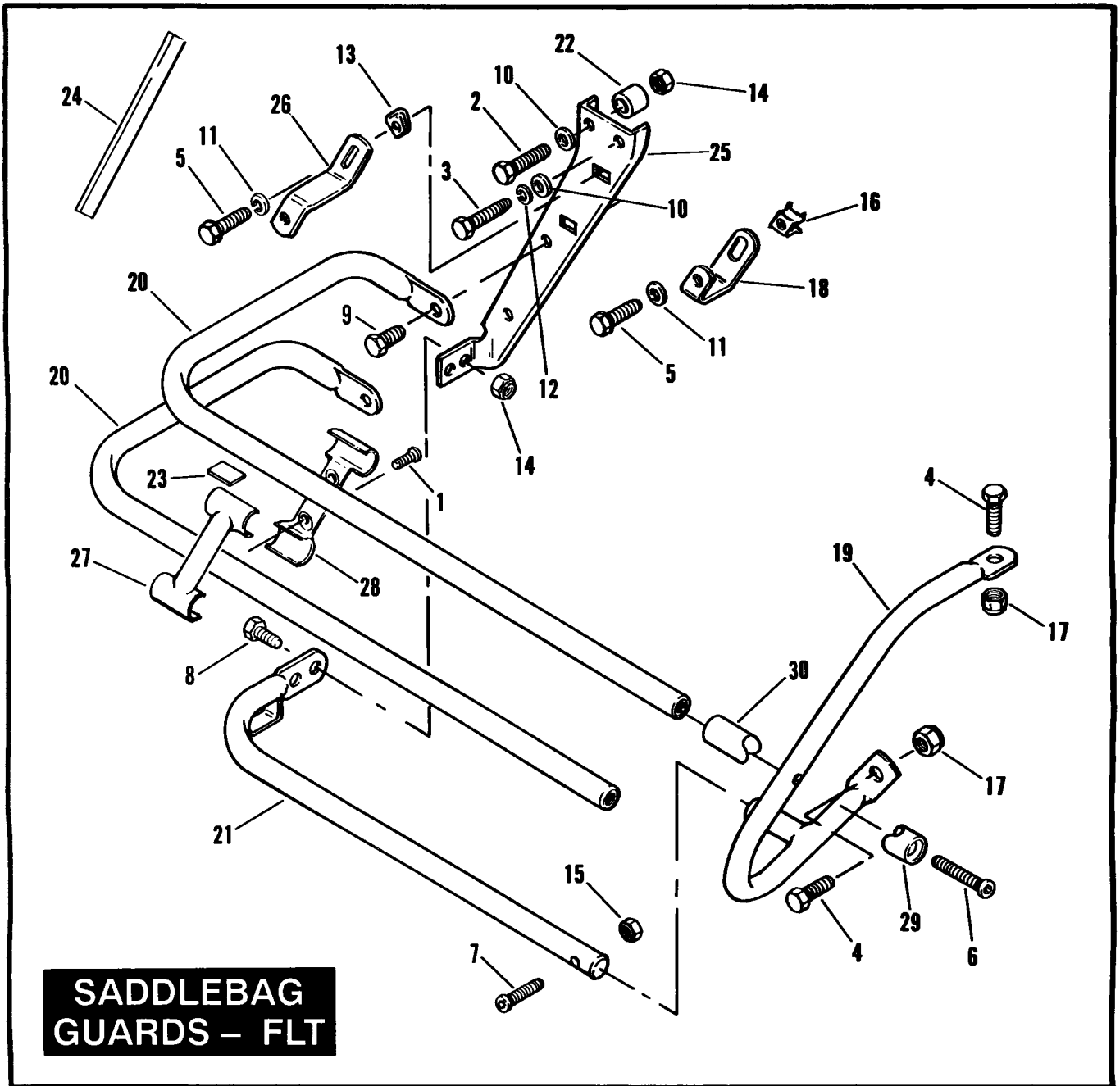

INDEX NO.	PART NO.	DESCRIPTION	FLT MODELS	FXR MODELS	SOFTAIL MODELS	DYNA MODELS
1	1750	SCREW (4)	93*-DJ/M/P	--	--	--
2	2818	BOLT (2)	93*-ALL	--	--	--
3	2882W	BOLT (2)	93*-DJ/M/P	--	--	--
4	2889	BOLT (4)	93-ALL	--	--	--
	4713W	SCREW (4)	94*-ALL	--	--	--
5	3574	SCREW (4)	93*-ALL	--	--	--
6	3584	SCREW (4)	93*-DJ/M/P	--	--	--
7	3601	SCREW (2)	93*-ALL	--	--	--
8	3987	SCREW (4)	93*-ALL	--	--	--
9	4391	SCREW (4)	93*-DJ/M/P	--	--	--
10	6702	WASHER (4)	93*-ALL	--	--	--
11	6703	WASHER (4)	93*-ALL	--	--	--
12	7041	LOCKWASHER (6)	93*-ALL	--	--	--
13	7490	CLIP NUT (2)	93*-ALL	--	--	--
14	7531	LOCKNUT (6)	93*-ALL	--	--	--
15	7686	LOCKNUT (2)	93*-ALL	--	--	--
16	7743	CLIP NUT (2)	93*-ALL	--	--	--
17	7776W	LOCKNUT (4)	93-ALL	--	--	--
	7667	LOCKNUT (4)	94*-ALL	--	--	--
18	47449-93	BRACKET, front (2)	93*-ALL	--	--	--
19	49172-93	GUARD, left	93*-DJ/M/P	--	--	--
	49187-79	GUARD, left	93*-FA/D	--	--	--
	49176-93	GUARD, right	93*-FA/D	--	--	--
	49188-93	GUARD, right	93*-DJ/M/P	--	--	--
20	49193-93	GUARD, saddlebags (4)	93*-DJ/M/P	--	--	--
21	49194-85	SUPPORT, saddlebag - left	93*-ALL	--	--	--
	90781-93	SUPPORT, saddlebag - right	93*-ALL	--	--	--
22	59060-92	SPACER (2)	93*-ALL	--	--	--
23	90180-93	PAD (2)	93*-DJ/M/P	--	--	--
24	90594-85	CUSHION (2)	93*-ALL	--	--	--
25	90718-79A	SUPPORT BRACKET, left	93*-ALL	--	--	--
	90720-79A	SUPPORT BRACKET, right	93*-ALL	--	--	--
26	90801-93	BRACKET, saddlebag mounting (2)	93*-ALL	--	--	--
27	90934-93	CLAMP, rear left-outer	93*-DJ/M/P	--	--	--
	90946-93	CLAMP, rear right-outer	93*-DJ/M/P	--	--	--
28	90935-93	CLAMP, rear right-inner	93*-DJ/M/P	--	--	--
	90936-93	CLAMP, rear left-inner	93*-DJ/M/P	--	--	--
29	90943-93	MOUNT, guard (4)	93*-DJ/M/P	--	--	--
30	90945-93	MOUNT, guard (4)	93*-DJ/M/P	--	--	--

FLT MODELS

FLHTC DJ
 FLTC-U DM
 FLHTC-U DP
 FLHS FA
 FLHR FD

FXR MODELS

FXR EA
 FXRS-SP EG
 FXLR EL
 FXRS-CON EM

SOFTAIL MODELS

FLSTC BJ
 FXSTC BK
 FXSTS BL
 FLSTF BM
 FLSTN BN

DYNA MODELS

FXDL GD
 FXDWG GE
 FXDS-CON GG

MIRRORS

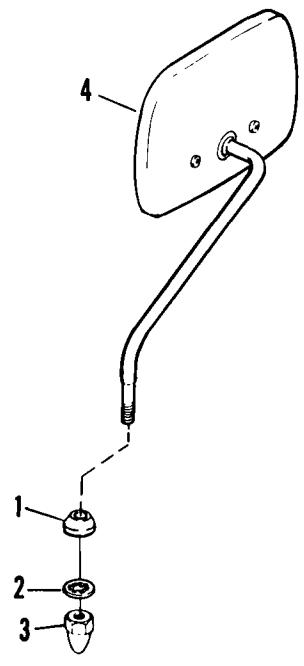

INDEX NO.	PART NO.	DESCRIPTION	FLT MODELS	FXR MODELS	SOFTAIL MODELS	DYNA MODELS
1	5774	SPACER (2)	93*-ALL	93*-ALL	93*-ALL	93*-ALL
2	7127	LOCKWASHER (2)	93*-ALL	93*-ALL	93*-ALL	93*-ALL
3	7736	ACORN NUT (2)	93*-ALL	93*-ALL	93*-ALL	93*-ALL
4	91875-88	MIRROR KIT, short - right - convex	93*-ALL	93*-EA/M	93*-ALL	93*-ALL
	91892-88	MIRROR KIT, short - left - convex	93*-ALL	93*-EA/M	93*-ALL	93*-ALL
	91902-88	MIRROR KIT, long - left - convex	--	93*-EG/L	--	--
	91904-88	MIRROR KIT, long - right - convex	--	93*-EG/L	--	--

FLT MODELS

FLHTC DJ
 FLTC-U DM
 FLHTC-U DP
 FLHS FA
 FLHR FD

FXR MODELS

FXR EA
 FXRS-SP EG
 FXLR EL
 FXRS-CON EM

SOFTAIL MODELS

FLSTC BJ
 FXSTC BK
 FXSTS BL
 FLSTF BM
 FLSTN BN

DYNA MODELS

FXDL GD
 FXDWG GE
 FXDS-CON GG

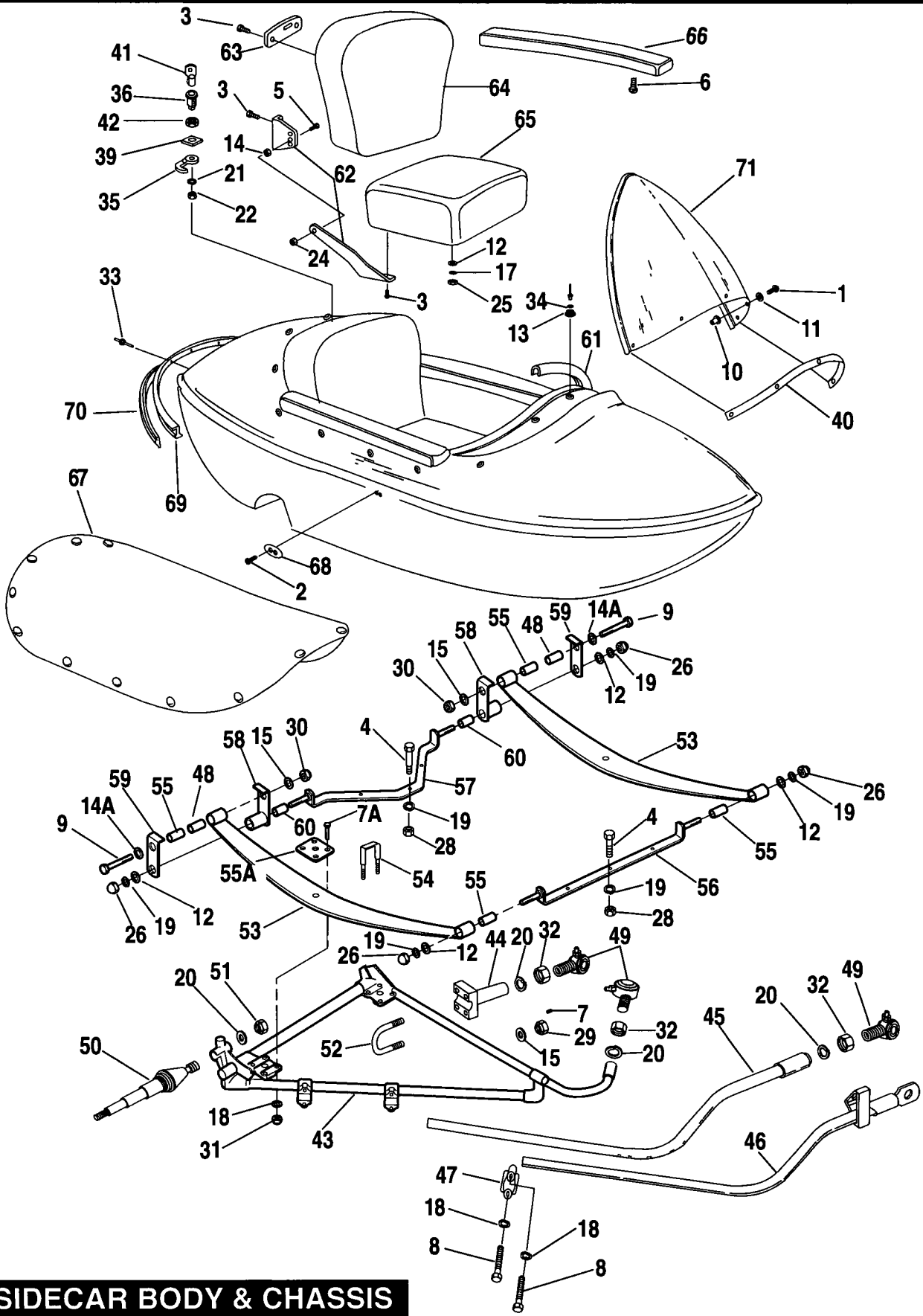

**SIDECAR BODY & CHASSIS
TLE & RLE**

INDEX NO.	PART NO.	DESCRIPTION	FLT MODELS	FXR MODELS	SOFTAIL MODELS	DYNA MODELS
NOTE: REFER TO DEALER ACCESSORY GUIDE FOR PAINTED PART NUMBERS.						
1	933	SCREW (7)	93*-GX	93*-HX	--	--
2	2216W	SCREW (2)	93*-GX,KX	93*-HX	--	--
3	2420	SCREW (10)	93*-GX	93*-HX	--	--
4	2887W	BOLT (6)	93*-GX,KX	93*-HX	--	--
5	2773	SCREW (2)	93*-GX	93*-HX	--	--
6	2920	SCREW (6)	93*-GX	93*-HX	--	--
7	3233	SET SCREW (2)	93*-GX,KX	93*-HX	--	--
7A	3764	SCREW (8)	94*-GX,KX	94*-HX	--	--
8	3946	BOLT (4)	93*-GX,KX	93*-HX	--	--
9	4401W	BOLT (2)	93*-GX,KX	93*-HX	--	--
10	5207	WELL NUT (7)	93*-GX	93*-HX	--	--
11	6054	WASHER (7)	93*-GX	93*-HX	--	--
12	6238	WASHER (4)	93*-GX,KX	93*-HX	--	--
13	6335	WASHER (16)	93*-GX,KX	93*-HX	--	--
14	6410	WASHER (2)	93*-GX	93*-HX	--	--
14A	6416	WASHER (4)	93*-GX,KX	93*-HX	--	--
15	6701	WASHER (4)	93*-GX,KX	93*-HX	--	--
17	7036	LOCKWASHER (4)	93*-GX	93*-HX	--	--
18	7039	LOCKWASHER (12; 2-1994 & later)	93*-GX,KX	93*-HX	--	--
19	7041	LOCKWASHER (4)	93*-GX,KX	93*-HX	--	--
20	7043	LOCKWASHER (3;4-HX)	93*-GX,KX	93*-HX	--	--
21	7128	LOCKWASHER	93*-GX	93*-HX	--	--
22	7586	NUT	93*-GX	93*-HX	--	--
24	7686	LOCKNUT (2)	93*-GX	93*-HX	--	--
25	7688	NUT (4)	93*-GX	93*-HX	--	--
26	7736	ACORN NUT (4)	93*-GX,KX	93*-HX	--	--
28	7748W	NUT (6)	93*-GX,KX	93*-HX	--	--
29	7775	LOCKNUT (4)	93*-GX,KX	93*-HX	--	--
30	7780	LOCKNUT (2)	93*-GX,KX	93*-HX	--	--
31	7827W	LOCKNUT (8)	94*-GX,KX	94*-HX	--	--
	7837W	NUT (8)	93*-GX,KX	93*-HX	--	--
32	7855W	JAM NUT (2;3-HX)	93*-GX,KX	93*-HX	--	--
33	8700	POP RIVET (50)	93*-GX,KX	93*-HX	--	--
34	47076-72	SNAP BASE	93*-GX,KX	93*-HX	--	--
35	53583-92	CAM HOOK	93*-GX	93*-HX	--	--
36	53584-92	LOCK	93*-GX	93*-HX	--	--
	53593-92	LOCK ASM. w/ #21, 22, 36, 41 & 42	93*-GX,KX	93*-HX	--	--

FLT MODELS
 TLE GX
 TLE-ULTRA KX
FXR MODELS
 RLE HX

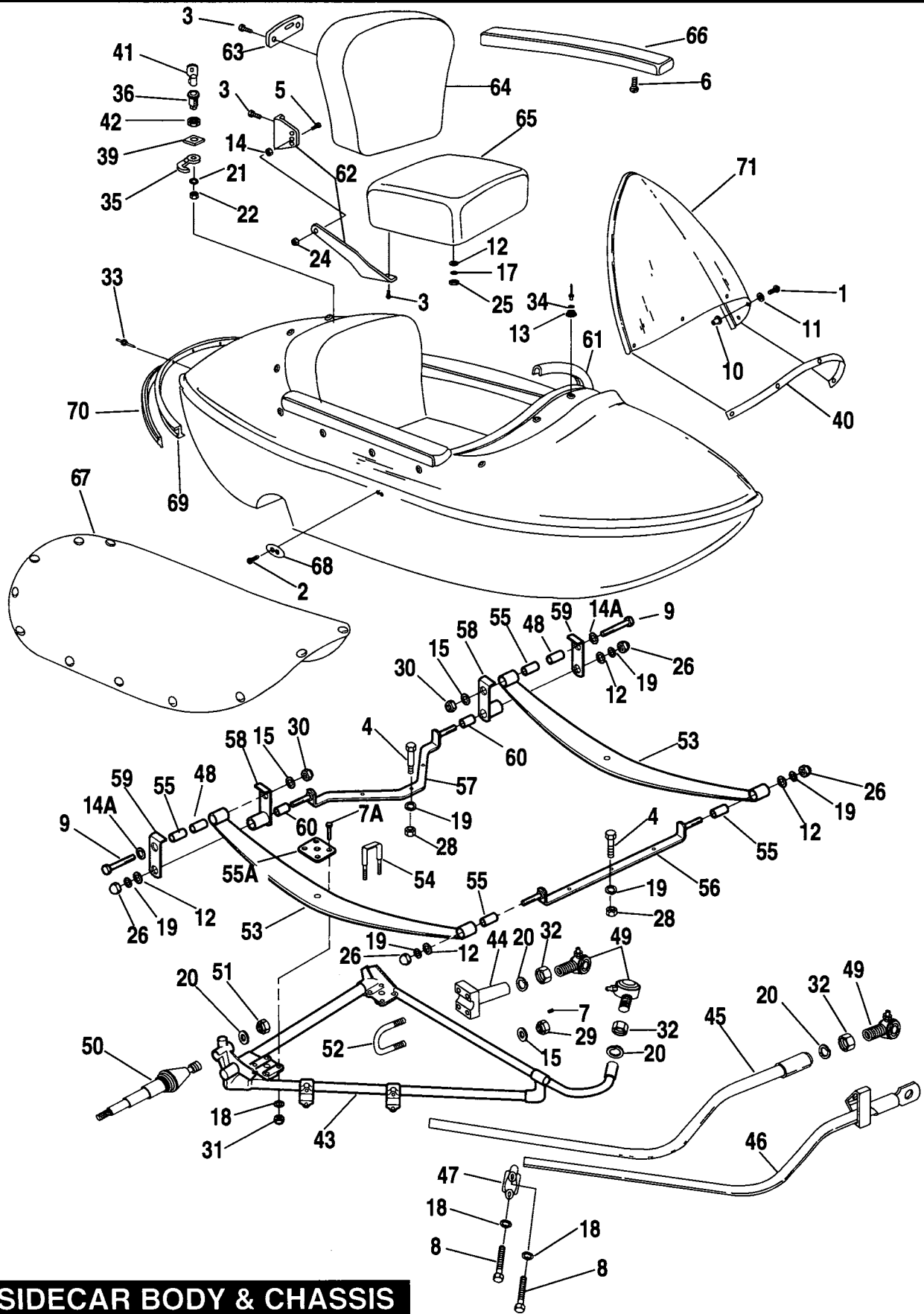

**SIDECAR BODY & CHASSIS
TLE & RLE**

INDEX NO.	PART NO.	DESCRIPTION	FLT MODELS	FXR MODELS	SOFTAIL MODELS	DYNA MODELS
39	53617-85	GUIDE, lock	93*-GX	93*-HX	--	--
40	58717-79	FOAM STRIP	93*-GX	93*-HX	--	--
41	71452-91A	KEY (specify 4 digit key code)	93*-GX	93*-HX	--	--
42	84850-92	NUT	93*-GX	93*-HX	--	--
43	87006-85	FRAME ASSEMBLY, sidecar	--	93*-HX	--	--
	87160-83	FRAME ASSEMBLY, sidecar	93*-GX,KX	--	--	--
44	87014-85	REAR MOUNTING ASSEMBLY	--	93*-HX	--	--
	87157-87	REAR MOUNTING ASSEMBLY	93*-GX,KX	--	--	--
45	87030-85	BRACE, sidecar frame	--	93*-HX	--	--
46	87056-83B	BRACE, sidecar frame	93*-GX,KX	--	--	--
47	87117-36	LOWER CLAMP (2)	93*-GX,KX	93*-HX	--	--
48	87120-79	SPACER, turn signal & spring shackle (2)	93*-GX,KX	93*-HX	--	--
49	87159-83	ROD END, sidecar mounting (2; 3 - HX)	93*-GX,KX	93*-HX	--	--
50	87435-83	AXLE	93*-GX,KX	93*-HX	--	--
51	87444-33	AXLE NUT, inside sidecar frame	93*-GX,KX	93*-HX	--	--
52	87701-79	U-BOLT, rear mounting bracket	93*-GX,KX	93*-HX	--	--
53	88100-24A	SIDECAR SPRING (2)	93-GX,KX	93-HX	--	--
	88100-94	SIDECAR SPRING, single leaf (2)	94*-GX,KX	94*-HX	--	--
54	88172-25	U-BOLT, springs (4)	93-GX,KX	93-HX	--	--
55	88174-37	SPRING BUSHING (4)	93-GX,KX	93-HX	--	--
	88174-94	SPRING BUSHING (4)	94*-GX,KX	94*-HX	--	--
55A	88175-94	SPRING PLATE (2)	94*-GX,KX	94*-HX	--	--
56	88261-36	SUPPORT ROD, front	93-GX,KX	93-HX	--	--
57	88264-36	SUPPORT ROD, rear	93*-GX,KX	93*-HX	--	--
58	88301-79	SHACKLE PLATE w/ bushing, spring (2)	93*-GX,KX	93*-HX	--	--
59	88302-79	SHACKLE PLATE, spring-outer (2)	93*-GX,KX	93*-HX	--	--
60	88314-37	BUSHING, shackle plate (2)	93*-GX,KX	93*-HX	--	--
61	88425-67	TRIM STRIP, body top (black)	93*-GX	93*-HX	--	--
62	88426-91	HINGE ASSEMBLY, seat - right	93*-GX	93*-HX	--	--
	88427-91	HINGE ASSEMBLY, seat - left	93*-GX	93*-HX	--	--
63	88428-91	LOCKPLATE	93*-GX	93*-HX	--	--
64	88481-91	BACK CUSHION	93*-GX	93*-HX	--	--
65	88487-91	SEAT CUSHION	93*-GX	93*-HX	--	--
66	88503-91A	ARM REST CUSHION - left	93*-GX	93*-HX	--	--
	88504-91A	ARM REST CUSHION - right	93*-GX	93*-HX	--	--
67	88528-91	COVER, sidecar body	93*-GX	93*-HX	--	--
68	88695-67	RETAINER CLIP, sidecar trim strip	93*-GX	93*-HX	--	--
69	88696-67	TRIM CHANNEL KIT (5 piece)	93*-GX,KX	93*-HX	--	--
70	88698-67	CHANNEL INSERT, trim strip (black vinyl)	93*-GX,KX	93*-HX	--	--
71	88862-91	WINDSHIELD, only	93*-GX	93*-HX	--	--

FLT MODELS **FXR MODELS**
TLE GX RLE HX
TLE-ULTRA KX

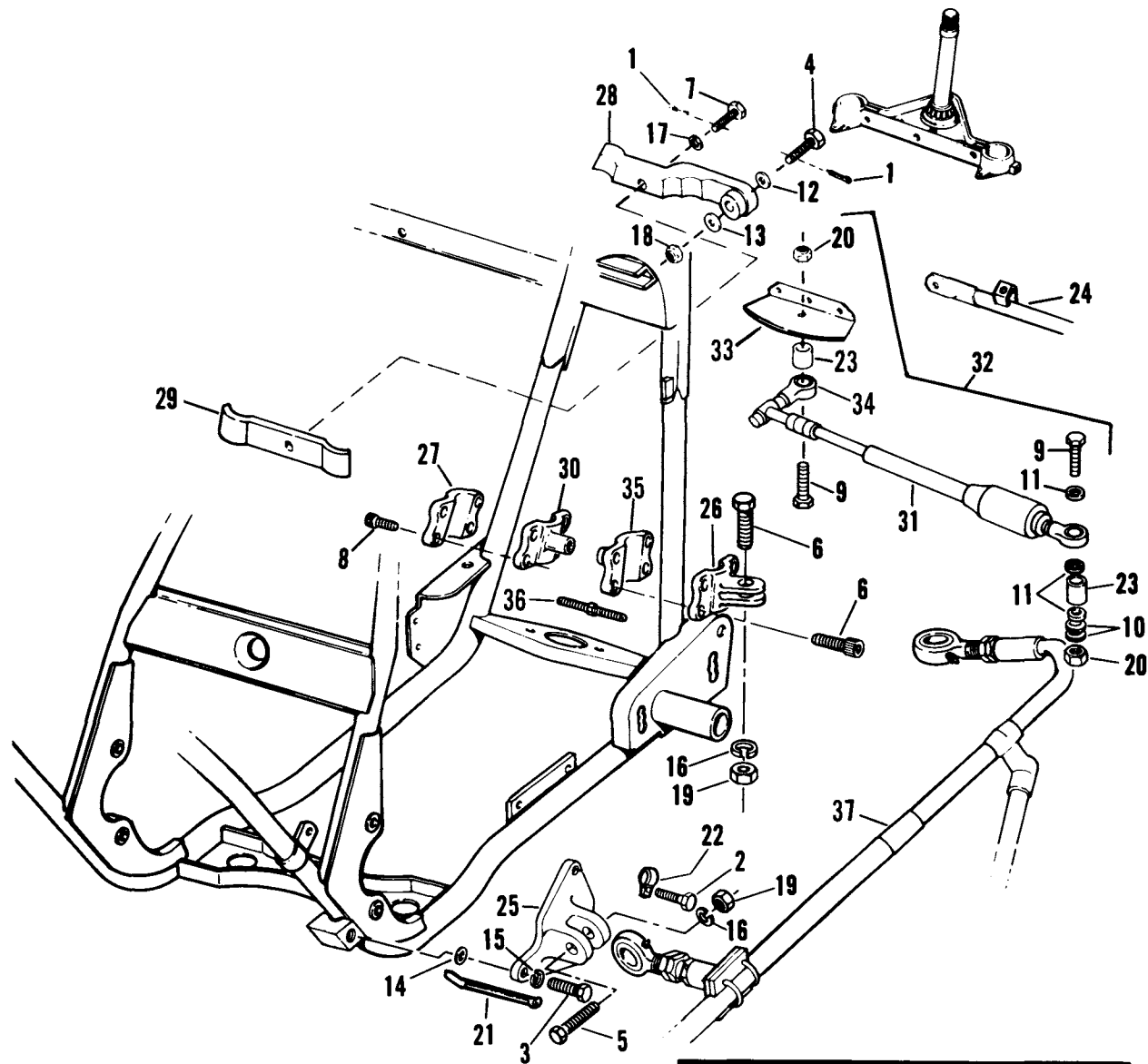

**SIDECAR CONNECTION
KIT — TLE**

INDEX NO.	PART NO.	DESCRIPTION	FLT MODELS	FXR MODELS	SOFTAIL MODELS	DYNA MODELS
1	559	COTTER PIN	93*-GX,KX	--	--	--
2	3764	BOLT	93*-GX,KX	--	--	--
3	3782	BOLT	93*-GX,KX	--	--	--
4	3949	BOLT	93*-GX,KX	--	--	--
5	4045	BOLT (2)	93*-GX,KX	--	--	--
6	4357	BOLT (4)	93*-GX,KX	--	--	--
7	4052	BOLT	93*-GX,KX	--	--	--
8	4356	BOLT (4)	93*-GX,KX	--	--	--
9	4420	BOLT , long (as required)	93*-GX,KX	--	--	--
	4720W	BOLT, short (as required)	93*-GX,KX	--	--	--
10	6519	WASHER (as required)	93*-GX,KX	--	--	--
11	6701	WASHER (3)	93*-GX,KX	--	--	--
12	6718	WASHER	93*-GX,KX	--	--	--
13	6723	WASHER	93*-GX,KX	--	--	--
14	6960	SHIM, 0.004" thick (as required)	93*-GX,KX	--	--	--
	6961	SHIM, 0.007" thick (as required)	93*-GX,KX	--	--	--
	6962	SHIM, 0.015" thick (as required)	93*-GX,KX	--	--	--
	6963	SHIM, 0.031" thick (as required)	93*-GX,KX	--	--	--
15	7039	LOCKWASHER	93*-GX,KX	--	--	--
16	7043	LOCKWASHER (2)	93*-GX,KX	--	--	--
17	7068	LOCKWASHER	93*-GX,KX	--	--	--
18	7843	CASTLE NUT	93*-GX,KX	--	--	--
19	7598	NUT (2)	93*-GX,KX	--	--	--
20	7775	NUT (2)	93*-GX,KX	--	--	--
21	10006	CABLE STRAP (8)	93*-GX,KX	--	--	--
22	10036	CLAMP	93*-GX,KX	--	--	--
23	59938-72	SPACER, mounting (2)	93*-GX,KX	--	--	--
24	87056-83B	BRACE, sidecar frame	93*-GX,KX	--	--	--
25	87114-93	BRACKET ASSEMBLY, rear	93*-GX,KX	--	--	--
26	87122-83	MOUNTING BRACKET, lower front - right	93*-GX,KX	--	--	--
27	87123-83	MOUNTING BRACKET, lower front - left	93*-GX,KX	--	--	--
28	87131-83B	UPPER CONNECTION, front	93*-GX,KX	--	--	--
29	87132-92	UPPER CONNECTION, rear	93*-GX,KX	--	--	--
30	87137-92	STABILIZER BRACKET, front	93*-GX,KX	--	--	--
31	87141-83	STEERING DAMPER	93*-GX,KX	--	--	--
32	87142-83	DAMPER MOUNTING KIT w/ 9, 11, 20 & 23	93*-GX,KX	--	--	--
33	87143-83	BRACKET, steering damper	93*-GX,KX	--	--	--
34	87144-83	ROD END BALL JOINT	93*-GX,KX	--	--	--
35	87148-92	STABILIZER BRACKET, right	93*-GX,KX	--	--	--
36	87156-83	STABILIZER, front	93*-GX,KX	--	--	--
37	87160-83	FRAME ASSEMBLY	93*-GX,KX	--	--	--
	87166-93	CONNECTION KIT, sidecar	93*-GX,KX	--	--	--

FLT MODELS FXR MODELS
 TLE GX RLE HX
 TLE-ULTRA KX

SIDECAR CONNECTION KIT — RLE

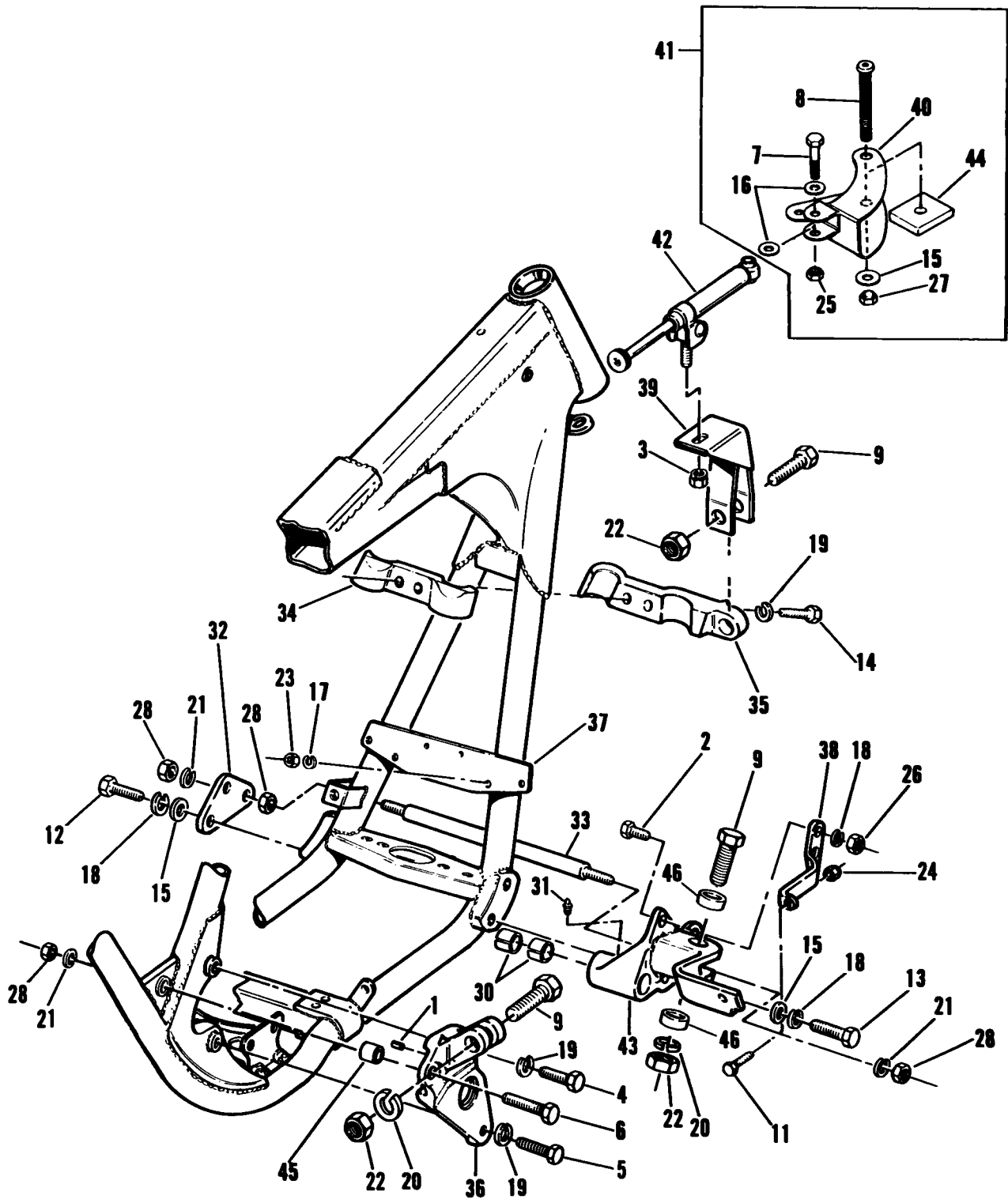

INDEX NO.	PART NO.	DESCRIPTION	FLT MODELS	FXR MODELS	SOFTAIL MODELS	DYNA MODELS
1	604	ROLL PIN	--	93*-HX	--	--
2	2879W	BOLT	--	93*-HX	--	--
3	3403	LOCKNUT	--	93*-HX	--	--
4	3764	BOLT	--	93*-HX	--	--
5	3769	BOLT	--	93*-HX	--	--
6	3958	BOLT	--	93*-HX	--	--
7	4041W	BOLT	--	93*-HX	--	--
8	4030	SCREW	--	93*-HX	--	--
9	4045	BOLT (3)	--	93*-HX	--	--
11	4701	BOLT	--	93*-HX	--	--
12	4716W	BOLT (2)	--	93*-HX	--	--
13	4721	BOLT (2)	--	93*-HX	--	--
14	4726	BOLT (2)	--	93*-HX	--	--
15	6701	WASHER (5)	--	93*-HX	--	--
16	6702	WASHER (2)	--	93*-HX	--	--
17	7036	LOCKWASHER (4)	--	93*-HX	--	--
18	7038	LOCKWASHER (5)	--	93*-HX	--	--
19	7039	LOCKWASHER (4)	--	93*-HX	--	--
20	7043	LOCKWASHER (3)	--	93*-HX	--	--
21	7068	LOCKWASHER (3)	--	93*-HX	--	--
22	7598	NUT (3)	--	93*-HX	--	--
23	7688	NUT (4)	--	93*-HX	--	--
24	7725	LOCKNUT	--	93*-HX	--	--
25	7727	LOCKNUT	--	93*-HX	--	--
26	7778	LOCKNUT	--	93*-HX	--	--
27	7783	NUT	--	93*-HX	--	--
28	7845	NUT (4)	--	93*-HX	--	--
	45452-87	FORK BRACE (chrome)(Not illustrated)	--	93*-HX	--	--
30	47247-83	BUSHING (2)	--	93*-HX	--	--
31	50972-75	FITTING, lubrication	--	93*-HX	--	--
32	87007-85	ADJUSTER PLATE, left front	--	93*-HX	--	--
	87008-88	SIDECAR CONNECTION KIT	--	93*-HX	--	--
33	87010-85	STABLIZER, front	--	93*-HX	--	--
34	87011-85	UPPER CONNECTION rear	--	93*-HX	--	--
35	87013-85	UPPER CONNECTION, front	--	93*-HX	--	--
36	87015-85	BRACKET ASSEMBLY, rear - w/ #1	--	93*-HX	--	--
37	87018-85	BRACKET, brake reservoir	--	93*-HX	--	--
38	87019-85	BRACKET, brake stop	--	93*-HX	--	--
39	87020-85	BRACKET, steering damper	--	93*-HX	--	--
40	87022-88	MOUNTING BRACKET	--	93*-HX	--	--
41	87023-88	DAMPER MOUNTING KIT	--	93*-HX	--	--
42	87024-85	STEERING DAMPER	--	93*-HX	--	--
43	87025-85A	BRACKET, lower front - w/ #30, 31 & 46	--	93*-HX	--	--
44	87048-88	SPACER	--	93*-HX	--	--
45	90480-85	SPACER, rear mount	--	93*-HX	--	--
46	90481-91	SPACER (2)	--	93*-HX	--	--

FLT MODELS

TLE GX
TLE-ULTRA KX

FXR MODELS

RLE HX

SIDECAR BRAKE - TLE & RLE

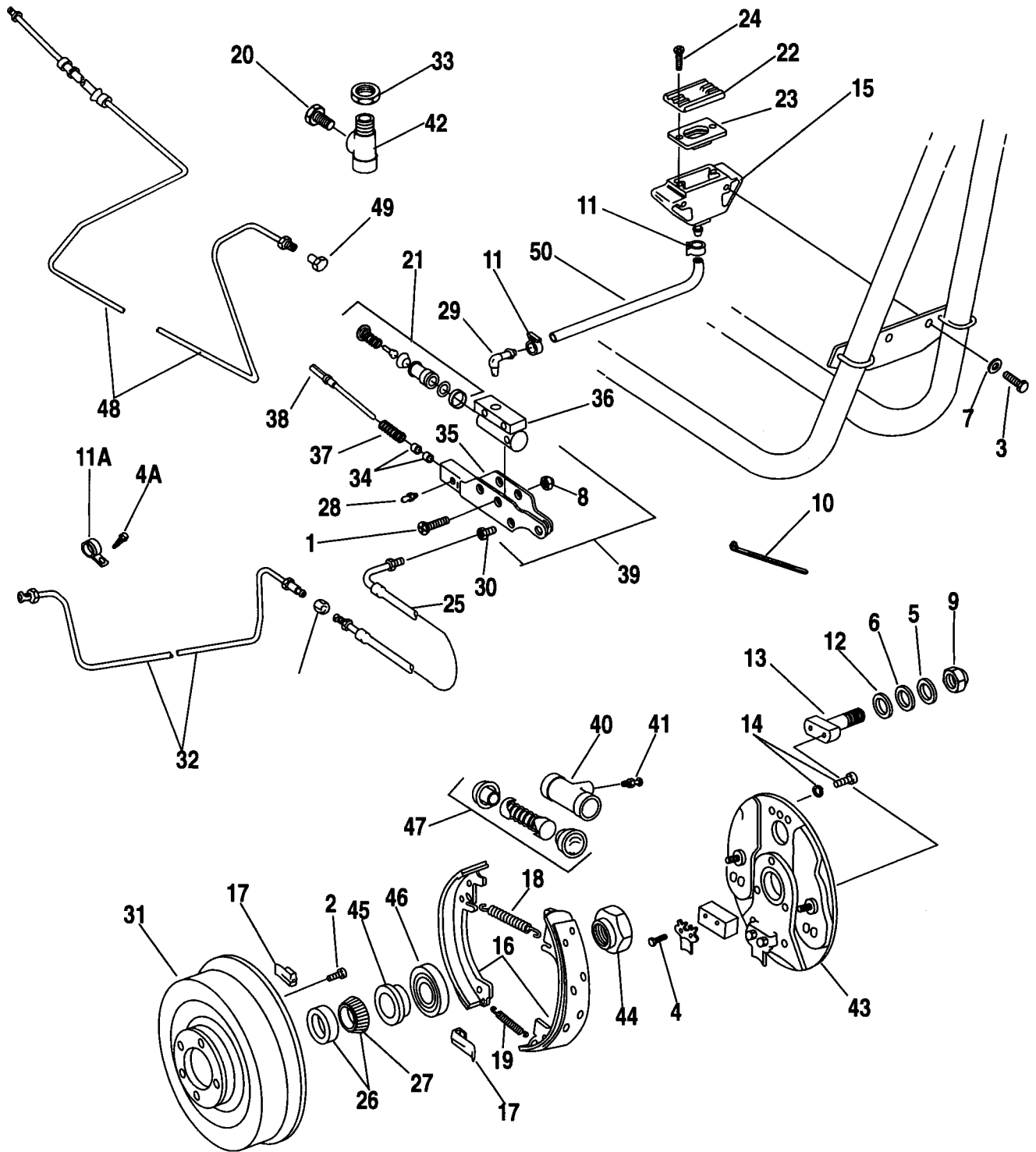

INDEX NO.	PART NO.	DESCRIPTION	FLT MODELS	FXR MODELS	SOFTAIL MODELS	DYNA MODELS
1	1610	SCREW (2)	--	93*-HX	--	--
2	1643	SCREW (5)	93*-GX,KX	93*-HX	--	--
3	3473	BOLT (2)	--	93*-HX	--	--
4	4020W	BOLT (2)	93*-GX,KX	93*-HX	--	--
4A	4091	SCREW (3)	93*-GX,KX	93*-HX	--	--
5	6700B	WASHER (as required)	93*-GX,KX	93*-HX	--	--
6	6712B	WASHER (as required)	93*-GX,KX	93*-HX	--	--
7	6716	WASHER (2)	--	93*-HX	--	--
8	7729	LOCKNUT (2)	--	93*-HX	--	--
9	7993	LOCKNUT	93*-GX,KX	93*-HX	--	--
10	10006	CABLE STRAP (5)	93*-GX,KX	93*-HX	--	--
11	10038	CLAMP (2)	--	93*-HX	--	--
11A	10059A	CLAMP (3)	93*-GX,KX	93*-HX	--	--
12	18268-48	WASHER (as required)	93*-GX,KX	93*-HX	--	--
13	41720-58	ANCHOR STUD	93*-GX,KX	93*-HX	--	--
14	41742-58A	SCREW & LOCKWASHER, brake cylinder (2)	93*-GX,KX	93*-HX	--	--
15	41804-84A	RESERVOIR, master cylinder	--	93*-HX	--	--
16	41801-58A	SET OF BRAKE SHOES & LININGS	93*-GX,KX	93*-HX	--	--
17	41835-58	HOLD DOWN, spring (2)	93*-GX,KX	93*-HX	--	--
18	41836-58	BRAKE SHOE SPRING, upper	93*-GX,KX	93*-HX	--	--
19	41837-58	BRAKE SHOE SPRING, lower	93*-GX,KX	93*-HX	--	--
20	42311-58	PLUG, brake line tee	93*-GX,KX	--	--	--
21	42374-77B	REPAIR KIT, master cylinder	--	93*-HX	--	--
22	45057-82	COVER, reservoir	--	93*-HX	--	--
23	42455-80	GASKET, reservoir	--	93*-HX	--	--
24	42534-90	SCREW (2)	--	93*-HX	--	--
25	45114-77	HOSE, brake line	--	93*-HX	--	--
26	48302-85	BEARING, brake drum	93*-GX,KX	93*-HX	--	--
27	48315-60	BEARING CUP, brake drum	93*-GX,KX	93*-HX	--	--
28	50972-75	FITTING, lubrication	--	93*-HX	--	--
29	63551-82	FITTING, reservoir hose	--	93*-HX	--	--
30	63609-72	FITTING, brake hose	--	93*-HX	--	--
31	87002-83	BRAKE DRUM ASSEMBLY	93*-GX,KX	93*-HX	--	--
32	87029-85	BRAKE LINE	93*-GX,KX	93*-HX	--	--
33	87032-85	FITTING, brake line	93*-GX,KX	93*-HX	--	--

FLT MODELS
 TLE GX
 TLE-ULTRA KX

FXR MODELS
 RLE HX

SIDECAR BRAKE - TLE & RLE

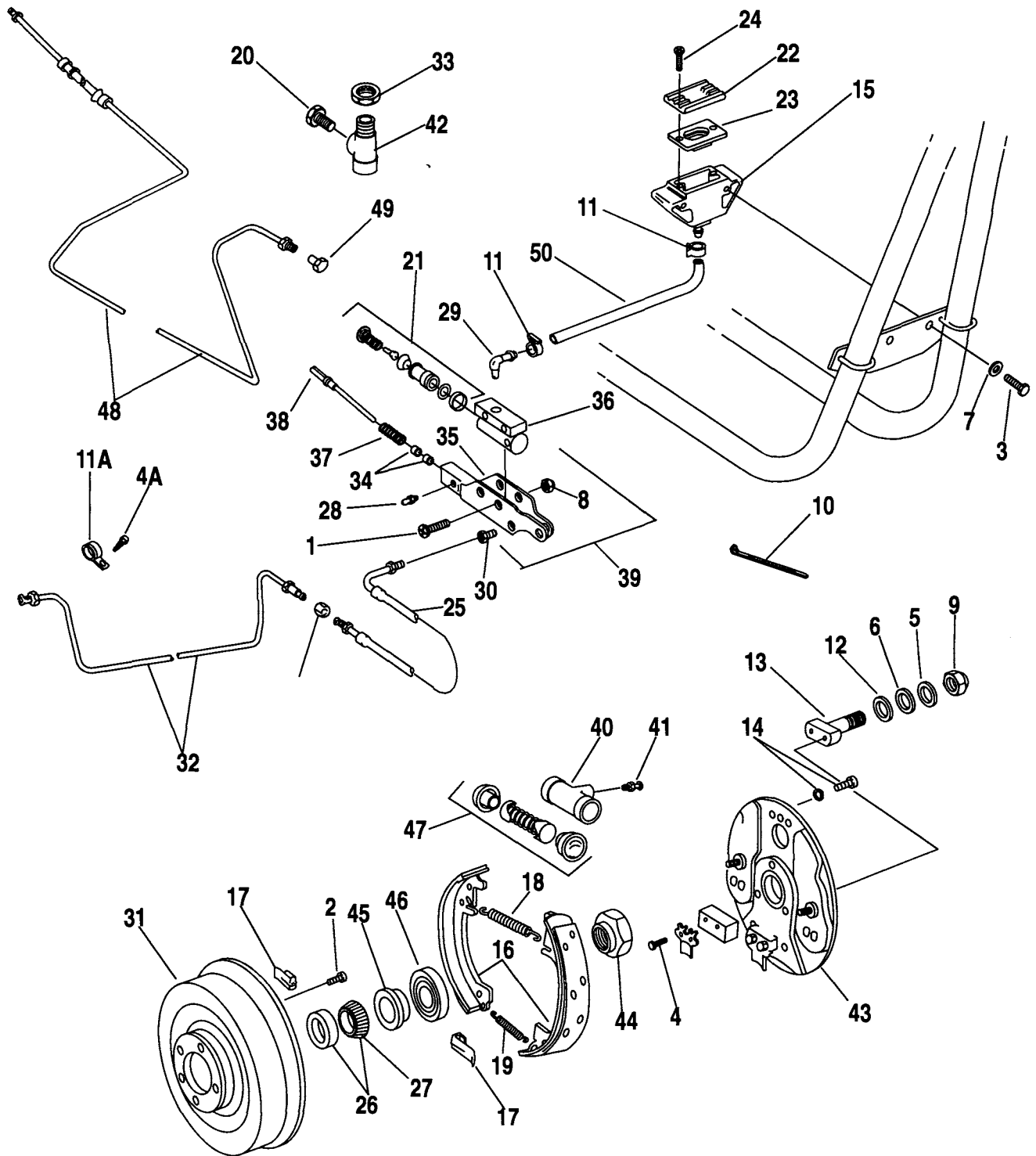

INDEX NO.	PART NO.	DESCRIPTION	FLT MODELS	FXR MODELS	SOFTAIL MODELS	DYNA MODELS
34	87038-85	BUSHING, housing (2)	--	93*-HX	--	--
35	87039-85	HOUSING, master cylinder	--	93*-HX	--	--
36	87040-85	MASTER CYLINDER	--	93*-HX	--	--
37	87041-85	SPRING, brake rod	--	93*-HX	--	--
38	87042-85	ROD, brake	--	93*-HX	--	--
39	87043-85	MASTER CYLINDER & HOUSING ASM.	--	93*-HX	--	--
40	87071-89	BRAKE CYLINDER, wheel (5/8")	93*-GX,KX	93*-HX	--	--
41	87073-79	BLEEDER FITTING, brake cylinder	93*-GX,KX	93*-HX	--	--
42	87113-83	TEE, sidecar brake line	93*-GX,KX	--	--	--
43	87672-76	SIDE PLATE	93*-GX,KX	93*-HX	--	--
44	87706-83	LOCKNUT, axle shaft	93*-GX,KX	93*-HX	--	--
45	87713-83	SPACER	93*-GX,KX	93*-HX	--	--
46	87714-83	OIL SEAL	93*-GX,KX	93*-HX	--	--
47	87752-89	REPAIR KIT, brake cylinder (5/8")	93*-GX,KX	93*-HX	--	--
48	87776-92	BRAKE LINE	93*-GX,KX	--	--	--
49	87778-64A	CAP, sidecar brake line	93*-GX,KX	--	--	--
		NOTE: Hose is sold in bulk length under the following part number. Cut to length.				
50	63573-82	HOSE, 5/16 I.D. (rubber) (25 ft. lg.)	--	93*-HX	--	--

FLT MODELS
 TLE GX
 TLE-ULTRA KX

FXR MODELS
 RLE HX

SIDECAR FENDER TLE & RLE

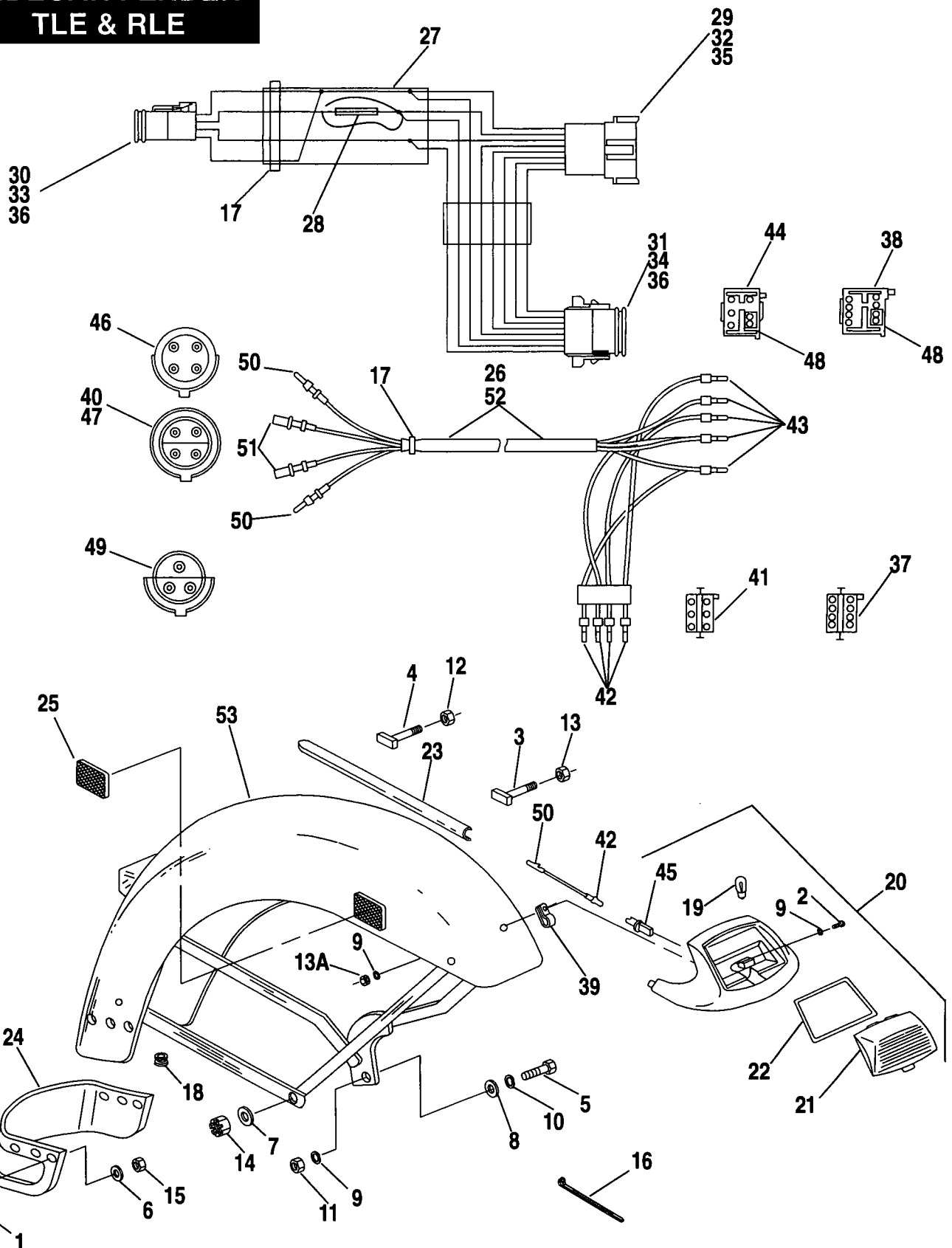

INDEX NO.	PART NO.	DESCRIPTION	FLT MODELS	FXR MODELS	SOFTAIL MODELS	DYNA MODELS
NOTE: REFER TO DEALER ACCESSORY GUIDE FOR PAINTED PART NUMBERS.						
1	2531	SCREW (6)	93*-GX,KX	--	--	--
2	2604	SCREW (2)	93*-GX,KX	93*-HX	--	--
3	3560W	TEE BOLT (2)	93*-GX,KX	93*-HX	--	--
4	3561WB	TEE BOLT (2)	93*-GX,KX	93*-HX	--	--
5	4721	BOLT	93*-GX,KX	93*-HX	--	--
6	6335	WASHER (6)	93*-GX,KX	--	--	--
7	6653A	WASHER	93*-GX,KX	93*-HX	--	--
8	6701	WASHER	93*-GX,KX	--	--	--
9	7118	LOCKWASHER (2)	93*-GX,KX	93*-HX	--	--
10	7130W	LOCKWASHER	93*-GX,KX	93*-HX	--	--
11	7601	NUT	93*-GX,KX	93*-HX	--	--
12	7624	LOCKNUT (4)	93*-GX,KX	93*-HX	--	--
13	7629	NUT (2)	93*-GX,KX	93*-HX	--	--
13A	7638	NUT	93*-GX,KX	93*-HX	--	--
14	7823	CASTLE NUT	93*-GX,KX	93*-HX	--	--
15	8131W	LOCKNUT (6)	93*-GX,KX	--	--	--
16	10006	CABLE STRAP (as required)	93*-GX,KX	93*-HX	--	--
17	10065	CABLE STRAP	93*-GX,KX	93*-HX	--	--
18	11410	GROMMET, tail lamp wiring	93*-GX,KX	93*-HX	--	--
19	53439-79	BULB, fender tip lamp	93*-GX,KX	93*-HX	--	--
20	59082-79	LAMP ASSEMBLY, fender tip	93*-GX,KX	93*-HX	--	--
21	59180-80	LENS, fender tip lamp	93*-GX,KX	93*-HX	--	--
22	59181-80	GASKET, fender tip lamp lens	93*-GX,KX	93*-HX	--	--
23	59211-74	SIDE TRIM STRIP (2)	93*-GX,KX	93*-HX	--	--
24	59231-86	TRIM, lower	93*-GX,KX	--	--	--
25	59255-72	REFLECTOR (red)	93*-GX,KX	93*-HX	--	--
26	70028-85A	WIRING HARNESS	93-GX,KX	--	--	--
27	70028-94	WIRING HARNESS	94*-GX,KX	--	--	--
includes the following:						
17	10065	CABLE STRAP	94*-GX,KX	--	--	--
28	70581-93	CONNECTOR (4)	94*-GX,KX	--	--	--
29	72108-94BK	RECEPTACLE, 8-way pin	94*-GX,KX	--	--	--
30	72114-94BK	PLUG, 4-way socket	94*-GX,KX	--	--	--
31	72118-94BK	PLUG, 8-way socket	94*-GX,KX	--	--	--
32	72148-94	PIN LOCK, sec. 8-way	94*-GX,KX	--	--	--
33	72154-94	SOCKET LOCK, sec. 4-way	94*-GX,KX	--	--	--
34	72158-94	SOCKET LOCK, sec. 8-way	94*-GX,KX	--	--	--
35	72190-94	TERMINAL, pin (8)	94*-GX,KX	--	--	--
36	72191-94	TERMINAL, socket (12)	94*-GX,KX	--	--	--

FLT MODELS		FXR MODELS
TLE	GX	RLE
TLE-ULTRA	KX	HX

SIDECAR FENDER TLE & RLE

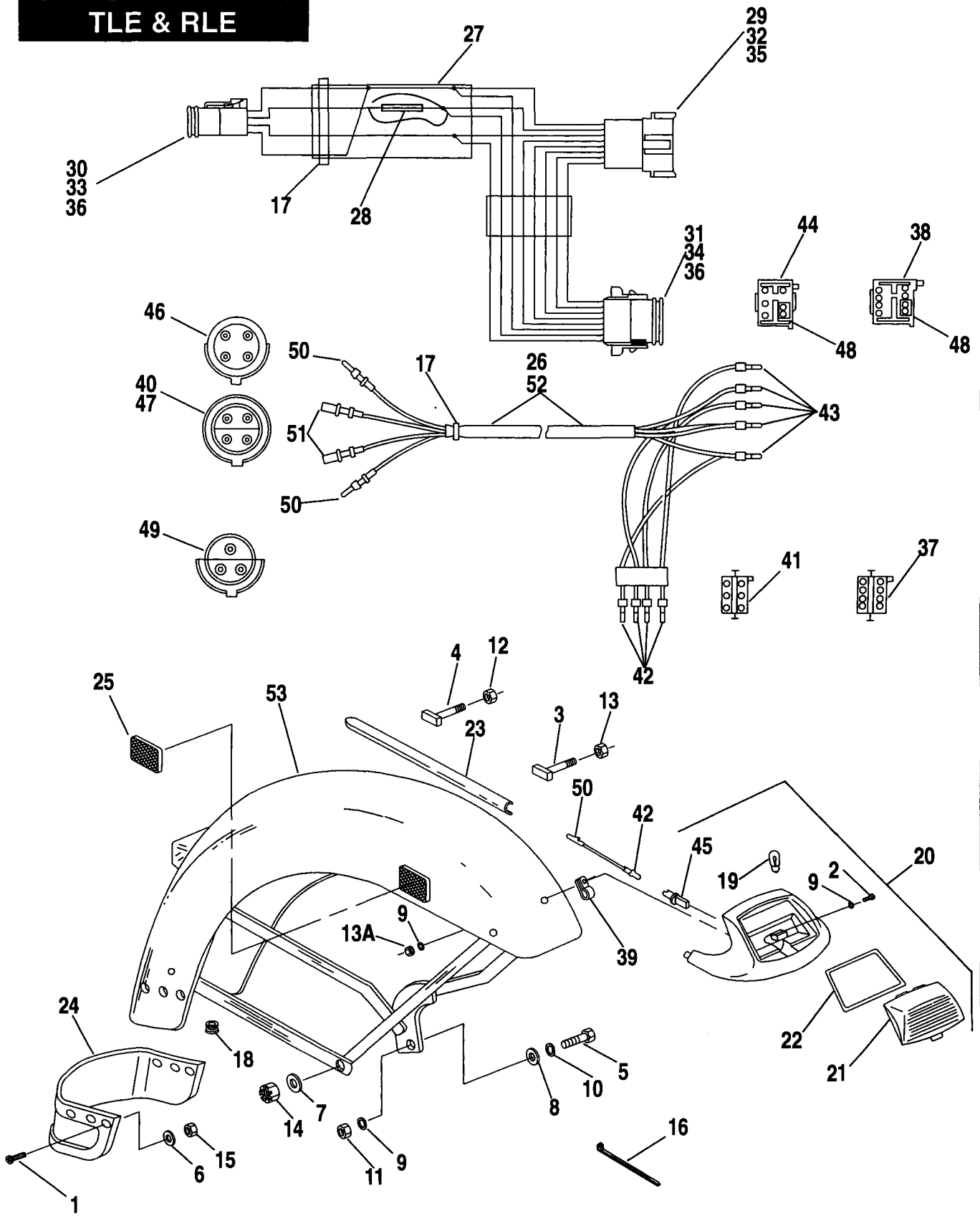

INDEX NO.	PART NO.	DESCRIPTION	FLT MODELS	FXR MODELS	SOFTAIL MODELS	DYNA MODELS
37	70287-81	CONNECTOR, eight socket	93-GX,KX	--	--	--
38	70288-81	CONNECTOR, eight pin	93-GX,KX	--	--	--
39	71795-63A	CLAMP	93*-GX,KX	93*-HX	--	--
40	72029-84	PLUG, four terminal	--	93*-HX	--	--
41	72037-71	CONNECTOR, six socket	--	93*-HX	--	-
42	72038-71	SOCKET, single pin (as required)	93-GX,KX	93*-HX	--	--
43	72039-71	PIN, single socket (5; 6 - GX, KX)	93-GX,KX	93*-HX	--	--
44	72041-71	CONNECTOR, six pin	--	93*-HX	--	--
45	72044-71	CONNECTOR, single socket	93-GX,KX	93*-HX	--	--
46	72054-84	PLUG RECEPTACLE	93-GX,KX	93*-HX	--	--
47	72057-84	PROTECTIVE PLUG (with sidecar removed)	93-GX,KX	93*-HX	--	--
48	72275-74	CONNECTOR TAB, two terminal	93-GX,KX	93*-HX	--	--
49	74521-77	PLUG RECEPTACLE	93*-GX,KX	93*-HX	--	--
50	74536-77A	PIN, single socket (3)	93-GX,KX	93*-HX	--	--
51	74539-77A	SOCKET, single pin (2)	93-GX,KX	93*-HX	--	--
52	87027-85	WIRING HARNESS	--	93*-HX	--	--
53	87901-83A	FENDER, sidecar (prime)	93*-GX,KX	93*-HX	--	--

FLT MODELS
 TLE GX
 TLE-ULTRA KX

FXR MODELS
 RLE HX

SIDECAR TAIL LAMP TLE & RLE

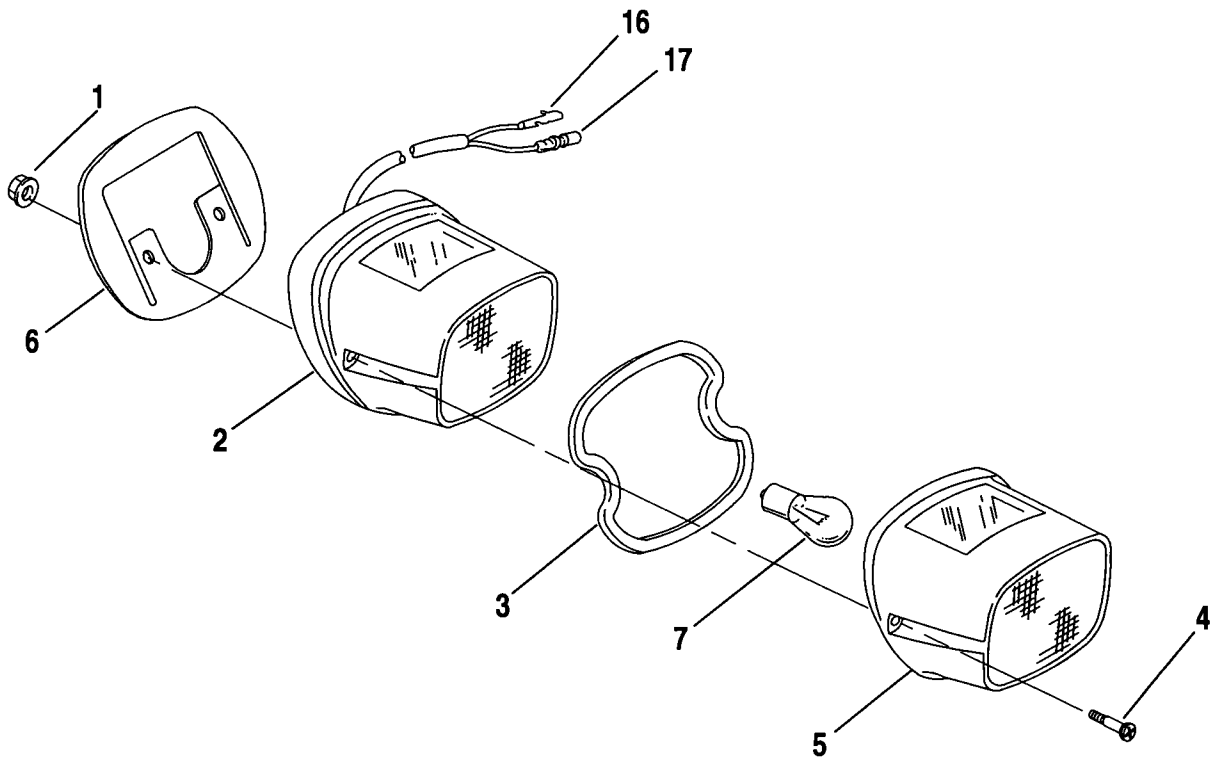
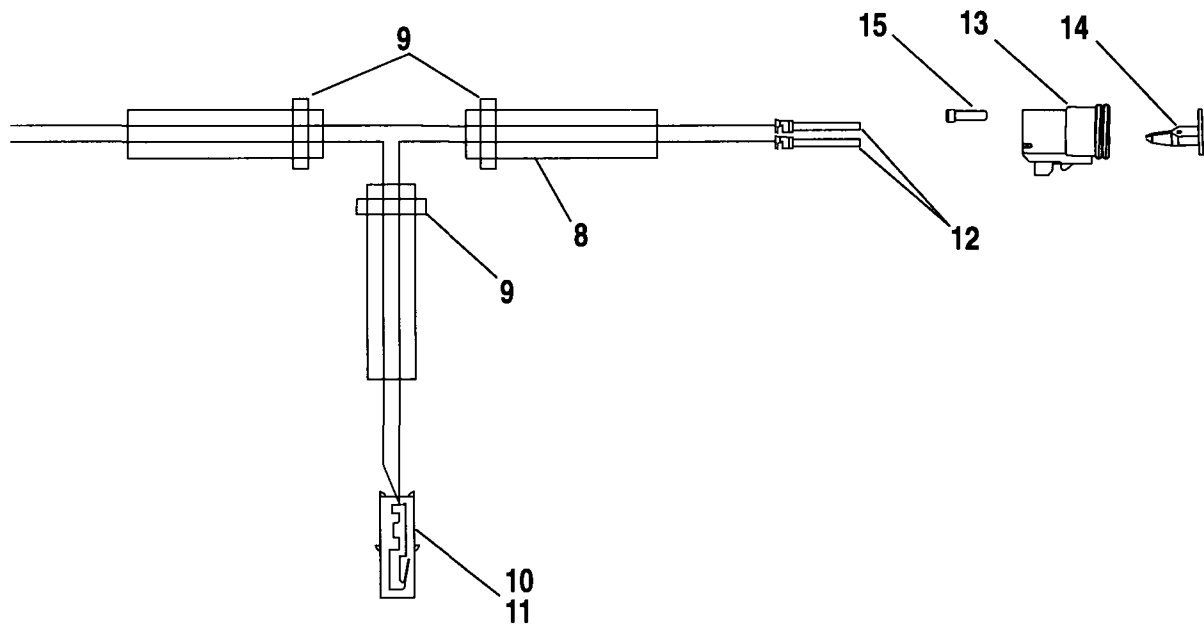

INDEX NO.	PART NO.	DESCRIPTION	FLT MODELS	FXR MODELS	SOFTAIL MODELS	DYNA MODELS
1	7501	SPEED NUT (2)	93*-GX,KX	93*-HX	--	--
2	68008-73B	TAIL LAMP ASSEMBLY	93-GX,KX	93*-HX	--	--
3	68027-90	GASKET, tail lamp lens	93*-GX,KX	93*-HX	--	--
4	68026-73	SCREW, tail lamp lens	93*-GX,KX	93*-HX	--	--
5	68033-90	LENS, tail lamp (red)	93*-GX,KX	93*-HX	--	--
6	68123-73	GASKET, tail lamp housing	93*-GX,KX	93*-HX	--	--
7	68168-89	BULB, tail lamp - 12V.	93*-GX,KX	93*-HX	--	--
8	70237-94	WIRING HARNESS, tail lamp includes the following:	94*-GX,KX	--	--	--
9	10065	CABLE STRAP (3)	94*-GX,KX	--	--	--
2	68008-73B	TAIL LAMP ASSEMBLY	94*-GX,KX	--	--	--
10	72038-71	SOCKET, single pin	94*-GX,KX	--	--	--
11	72044-71	CONNECTOR, single socket	94*-GX,KX	--	--	--
12	72191-94	TERMINAL, socket (2)	94*-GX,KX	--	--	--
13	72113-94BK	PLUG, 3-way socket	94*-GX,KX	--	--	--
14	72153-94	SOCKET LOCK, sec. 3-way	94*-GX,KX	--	--	--
15	72195-94	SEAL PIN	94*-GX,KX	--	--	--
16	74536-77A	PIN, single socket (2)	93-GX,KX	93*-HX	--	--
17	74539-77A	SOCKET, single pin	93-GX,KX	93*-HX	--	--

FLT MODELS
 TLE GX
 TLE-ULTRA KX

FXR MODELS
 RLE HX

SIDECAR TURN SIGNAL TLE & RLE

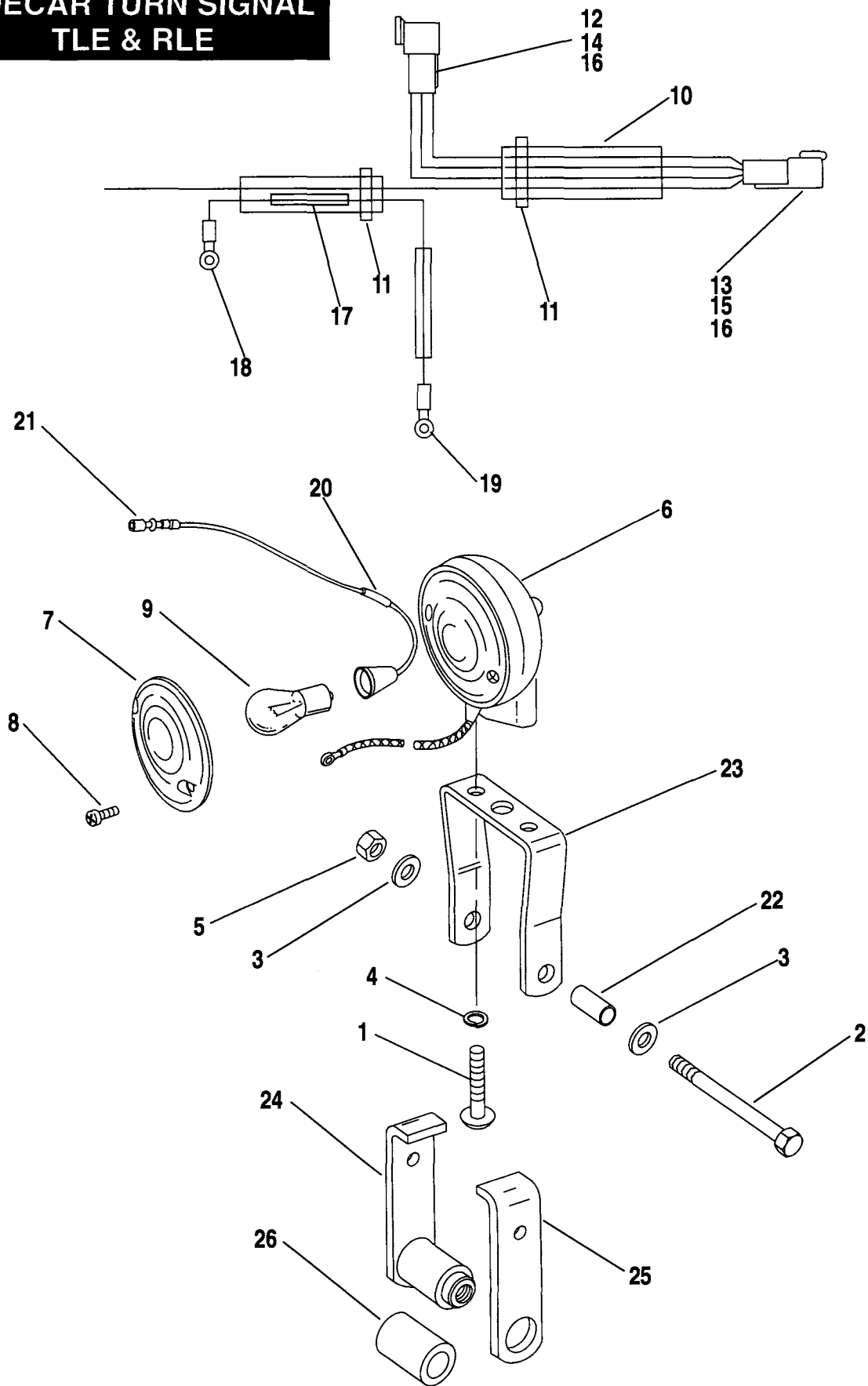

INDEX NO.	PART NO.	DESCRIPTION	FLT MODELS	FXR MODELS	SOFTAIL MODELS	DYNA MODELS
1	2664	SCREW (2)	93*-GX, KX	93*-HX	--	--
2	4401W	BOLT	93*-GX, KX	93*-HX	--	--
3	6416	WASHER (2)	93*-GX, KX	93*-HX	--	--
4	7069	LOCKWASHER (2)	93*-GX, KX	93*-HX	--	--
5	7780	LOCKNUT	93*-GX, KX	93*-HX	--	--
6	68402-86	LAMPw/ wire, turn signal (amber)	93-GX, KX	93*-HX	--	--
7	68440-86	LENS, turn signal	93*-GX, KX	93*-HX	--	--
8	68452-86	SCREW (2)	93*-GX, KX	93*-HX	--	--
9	68572-64B	BULB, turn signal	93*-GX, KX	93*-HX	--	--
10	70221-94	WIRING HARNESS includes the following:	94*-GX,KX	--	--	--
11	10065	CABLE STRAP (2)	94*-GX, KX	--	--	--
6	68402-86	LAMP w/ wire, turn signal (amber)	94*-GX, KX	--	--	--
12	72103-94BK	RECEPTACLE, 3-way pin	94*-GX, KX	--	--	--
13	72104-94BK	RECEPTACLE, 4-way pin	94*-GX, KX	--	--	--
14	72143-94	PIN LOCK, sec. 3-way	94*-GX, KX	--	--	--
15	72144-94	PIN LOCK, sec. 4-way	94*-GX, KX	--	--	--
16	72190-94	TERMINAL, pin (7)	94*-GX, KX	--	--	--
17	72249-94	HEAT SHRINK TUBE, .3 x 1"	94*-GX, KX	--	--	--
18	9857	TERMINAL, ring type - #10 hole	94*-GX, KX	--	--	--
19	9860	TERMINAL, ring type - 3/8 hole	94*-GX, KX	--	--	--
20	70581-73	CONNECTOR	93-GX, KX	93*-HX	--	--
21	74539-77A	SOCKET, single pin	93-GX, KX	93*-HX	--	--
22	87120-79	SPACER, turn signal & spring shackle	93*-GX, KX	93*-HX	--	--
23	87121-79	BRACKET, turn signal	93*-GX, KX	93*-HX	--	--
24	88301-79	SHACKLE PLATE w/bshg-turn signal & spring	93*-GX, KX	93*-HX	--	--
25	88302-79	SHACKLE PLATE, turn signal & spring	93*-GX, KX	93*-HX	--	--
26	88314-37	BUSHING, shackle plate	93*-GX, KX	93*-HX	--	--

FLT MODELS
 TLE GX
 TLE-ULTRA KX

FXR MODELS
 RLE HX

SIDECAR WHEEL - TLE & RLE

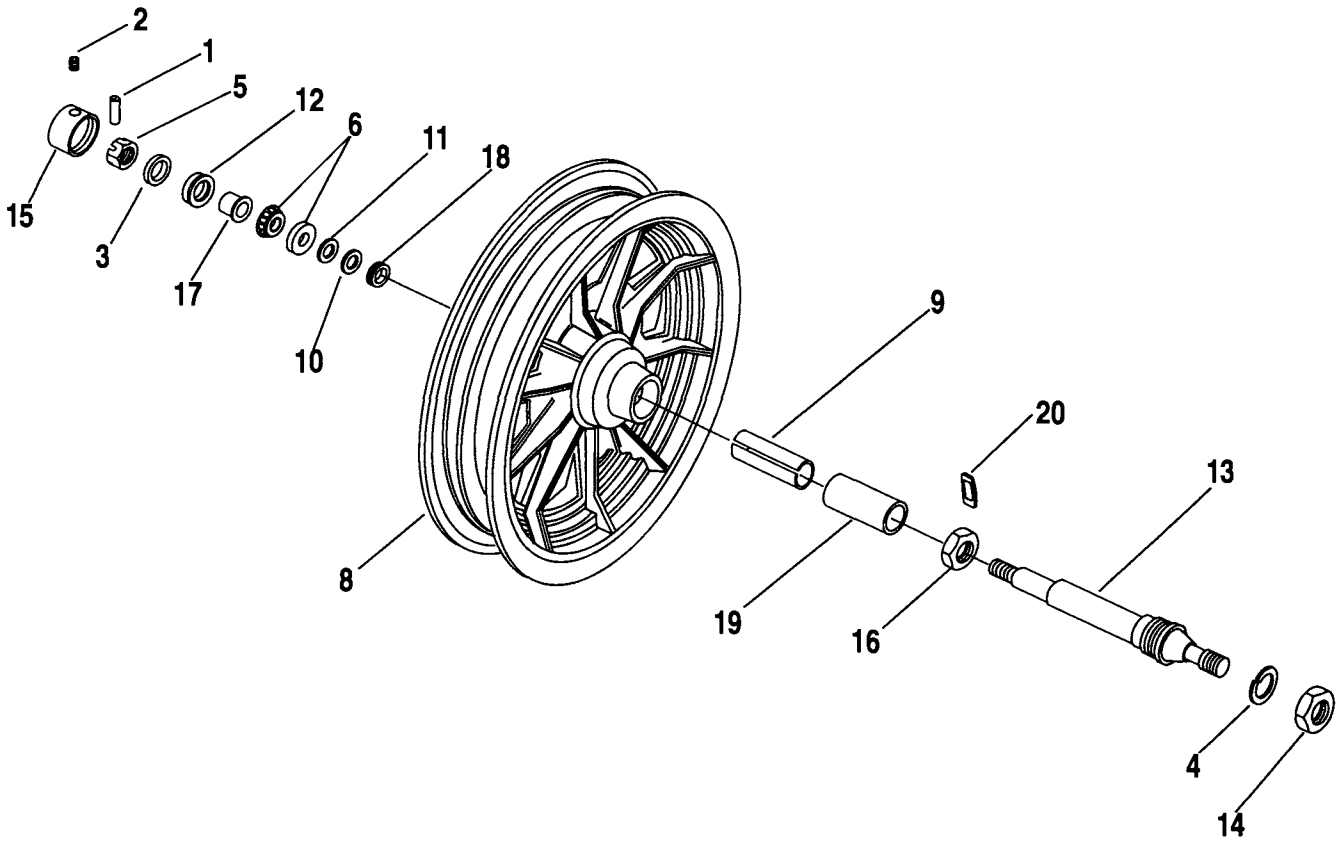

INDEX NO.	PART NO.	DESCRIPTION	FLT MODELS	FXR MODELS	SOFTAIL MODELS	DYNA MODELS
1	601	ROLL PIN	93*-GX, KX	93*-HX	--	--
2	3234W	SET SCREW	93*-GX, KX	93*-HX	--	--
3	6653A	WASHER	93*-GX, KX	93*-HX	--	--
4	7043	LOCKWASHER	93*-GX, KX	93*-HX	--	--
5	7823	CASTLE NUT	93*-GX, KX	93*-HX	--	--
6	9052	ROLLER BEARING w/ cup	93*-GX, KX	93*-HX	--	--
	40999-87	VALVE STEM	93*-GX, KX	93*-HX	--	--
8	41157-87	WHEEL ASSEMBLY, 16" - 10 spoke (black)	93*-GX, KX	93*-HX	--	--
9	43288-82	SLEEVE	93*-GX, KX	93*-HX	--	--
10	43290-82	SPACER, 0.032"	93*-GX, KX	93*-HX	--	--
	43291-82	SPACER, 0.016"	93*-GX, KX	93*-HX	--	--
	43292-82	SPACER, 0.008"	93*-GX, KX	93*-HX	--	--
	43293-82	SPACER, 0.004"	93*-GX, KX	93*-HX	--	--
	43294-82	SPACER, 0.002"	93*-GX, KX	93*-HX	--	--
11	43650-82	SPACER WASHER	93*-GX, KX	93*-HX	--	--
12	47519-83A	OIL SEAL	93*-GX, KX	93*-HX	--	--
13	87435-83	AXLE	93*-GX, KX	93*-HX	--	--
14	87444-33	AXLE NUT, inside sidecar frame	93*-GX, KX	93*-HX	--	--
15	87705-79	CAP, axle end	93*-GX, KX	93*-HX	--	--
16	87706-83	NUT	93*-GX, KX	93*-HX	--	--
17	87710-83	SPACER	93*-GX, KX	93*-HX	--	--
18	87711-83	SPACER	93*-GX, KX	93*-HX	--	--
19	87712-83	SLEEVE, bearing spacer	93*-GX, KX	93*-HX	--	--
20	95594-84	WHEEL WEIGHT, 1/2 oz. (black)	93*-GX, KX	93*-HX	--	--
	95595-84	WHEEL WEIGHT, 1/2 oz (plain)	93*-GX, KX	93*-HX	--	--

FLT MODELS
 TLE GX
 TLE-ULTRA KX

FXR MODELS
 RLE HX

SIDECAR - INTERIOR

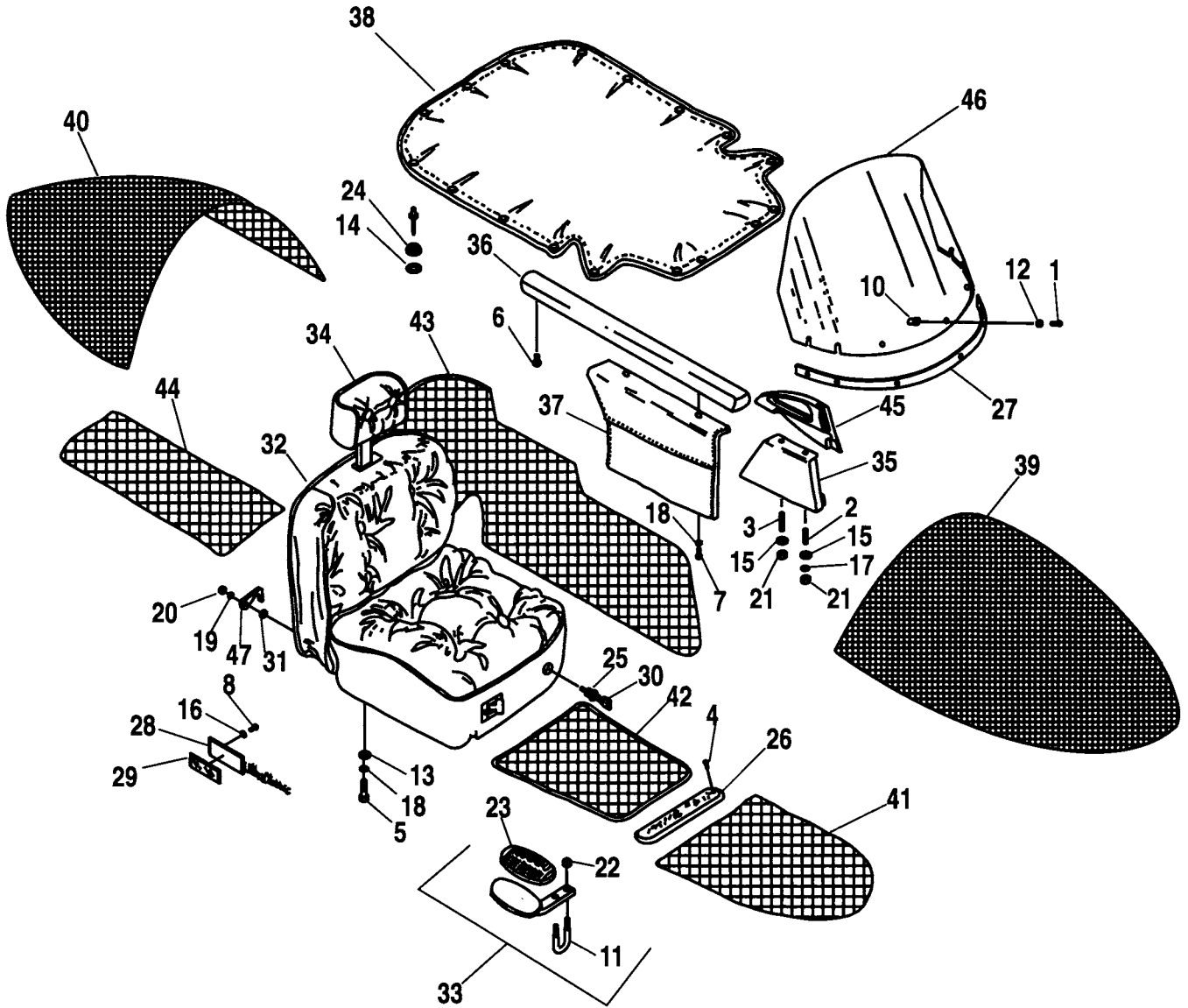

INDEX NO.	PART NO.	DESCRIPTION	FLT MODELS	FXR MODELS	SOFTAIL MODELS	DYNA MODELS
1	933	SCREW (7)	93*-KX	--	--	--
2	2522	STUD (2)	93*-KX	--	--	--
3	2527	STUD (2)	93*-KX	--	--	--
4	2731W	SCREW (2)	93*-KX	--	--	--
5	2818	BOLT (4)	93*-KX	--	--	--
6	2920	SCREW (2)	93*-KX	--	--	--
7	2929	SCREW (4)	93*-KX	--	--	--
8	3595	SCREW (3)	93*-KX	--	--	--
10	5207	WELL NUT (7)	93*-KX	--	--	--
11	5252	U-BOLT	93*-KX	--	--	--
12	6054	WASHER (nylon) (7)	93*-KX	--	--	--
13	6238	WASHER (4)	93*-KX	--	--	--
14	6335	WASHER (16)	93*-KX	--	--	--
15	6703	WASHER (4)	93*-KX	--	--	--
16	6717	WASHER (6)	93*-KX	--	--	--
17	7036	LOCKWASHER (2)	93*-KX	--	--	--
18	7041	LOCKWASHER (4)	93*-KX	--	--	--
19	7128	LOCKWASHER	93*-KX	--	--	--
20	7586	NUT	93*-KX	--	--	--
21	7688	NUT (4)	93*-KX	--	--	--
22	7739	LOCKNUT (2)	93*-KX	--	--	--
	36760-89	CABLE, seat recline (not illustrated)	93*-KX	--	--	--
23	36964-67	PAD, sidecar step	93*-KX	--	--	--
24	47076-72	SNAP BASE (16)	93*-KX	--	--	--
25	53584-92	LOCK	93*-KX	--	--	--
	53593-92	LOCK ASM., seat w/ #19, 20, 25, 30 & 31	93*-KX	--	--	--
26	58378-89	NAMEPLATE, footrest "Harley-Davidson"	93*-KX	--	--	--
27	58717-79	FOAM TAPE, windshield	93*-KX	--	--	--
28	59245-90	NAMEPLATE, fender	93*-KX	--	--	--
29	59259-90	REFLECTOR, fender (red)	93*-KX	--	--	--
30	71452-91A	KEY (specify 4 digit code)	93*-KX	--	--	--
31	84850-92	NUT	93*-KX	--	--	--

FLT MODELS
 TLE GX
 TLE-ULTRA KX

FXR MODELS
 RLE HX

SIDECAR - INTERIOR

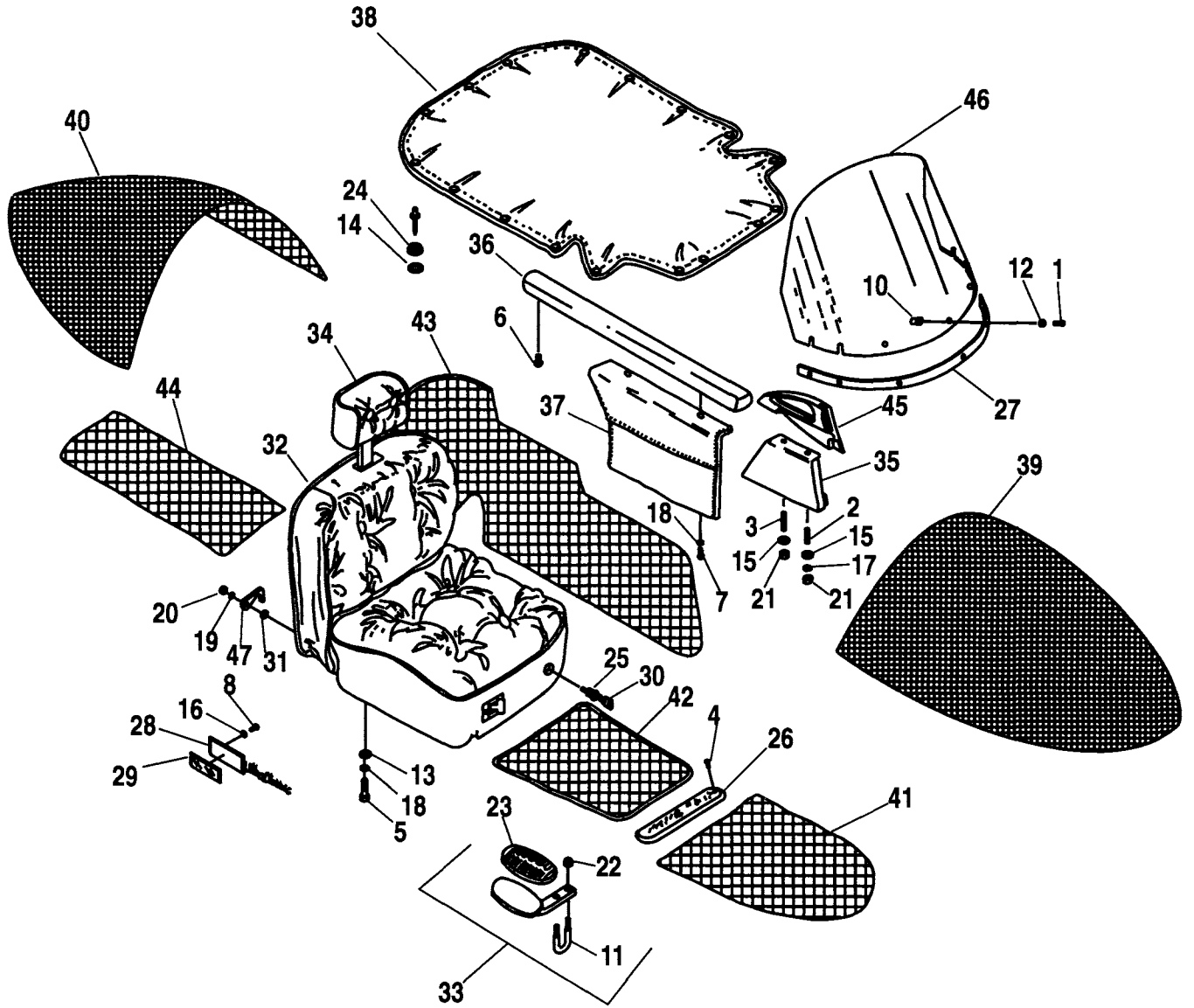

INDEX NO.	PART NO.	DESCRIPTION	FLT MODELS	FXR MODELS	SOFTAIL MODELS	DYNA MODELS
32	88489-89D	SEAT ASSEMBLY. w/ lock asm., recline cable & cam hook	93*-KX	--	--	--
33	88490-88A	SIDECAR STEP KIT w/ #11, 22 & 23	93*-KX	--	--	--
34	88492-89	HEADREST	93*-KX	--	--	--
35	88494-89	KNEE BOLSTER, right	93*-KX	--	--	--
	88495-89	KNEE BOLSTER, left	93*-KX	--	--	--
36	88496-89A	ARM REST CUSHION, right	93*-KX	--	--	--
	88497-89A	ARM REST CUSHION, left	93*-KX	--	--	--
37	88500-89	MAP POCKET, right	93*-KX	--	--	--
	88501-89	MAP POCKET, left	93*-KX	--	--	--
38	88530-89A	COVER, sidecar body (black)	93*-KX	--	--	--
39	88526-91	CARPET, top front	93*-GX,KX	93*-HX	--	--
40	88527-91	CARPET, top rear	93*-GX,KX	93*-HX	--	--
41	88531-91	CARPET, nose	93*-GX,KX	93*-HX	--	--
42	88536-91	CARPET, front lower	93*-GX,KX	93*-HX	--	--
43	88537-91	CARPET, left side	93*-GX,KX	93*-HX	--	--
	88538-91	CARPET, right side	93*-GX,KX	93*-HX	--	--
44	88539-91	CARPET, rear lower	93*-GX,KX	93*-HX	--	--
45	88545-93	HANDHOLD, left	93*-KX	--	--	--
	88546-93	HANDHOLD, right	93*-KX	--	--	--
46	88865-89	WINDSHIELD, only	93*-KX	--	--	--
47	90686-92	CAM HOOK	93*-KX	--	--	--

FLT MODELS **FXR MODELS**
TLE GX RLE HX
TLE-ULTRA KX

SOUND SYSTEM - ULTRA SIDECAR

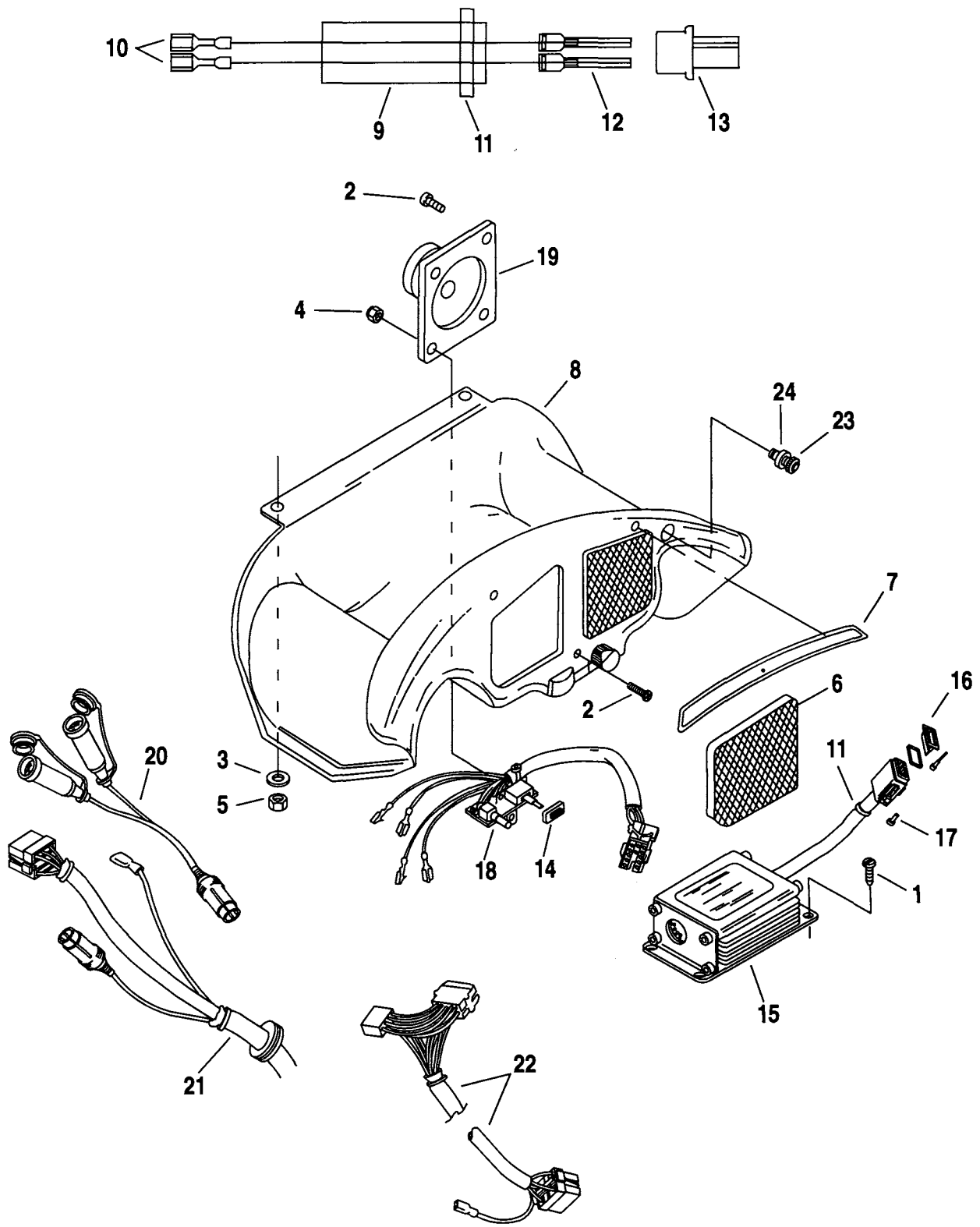

INDEX NO.	PART NO.	DESCRIPTION	FLT MODELS	FXR MODELS	SOFTAIL MODELS	DYNA MODELS
1	2731W	SCREW (6)	93*-KX	--	--	--
2	2646	SCREW (3)	93*-KX	--	--	--
3	6703	WASHER (2)	93*-KX	--	--	--
4	7608	NUT (6)	93*-KX	--	--	--
5	7688	LOCKNUT (2)	93*-KX	--	--	--
6	58184-86	SPEAKER GRILLE, left	93*-KX	--	--	--
	58186-86	SPEAKER GRILLE, right	93*-KX	--	--	--
7	58379-89	NAMEPLATE, "Ultra Sidecar"	93*-KX	--	--	--
8	60954-89	CONSOLE	93*-KX	--	--	--
	70184-93	WIRING HARNESS, lighter (not illus.)	93-KX	--	--	--
9	70184-94	WIRING HARNESS, lighter includes the following:	94*-KX	--	--	--
10	9907	TERMINAL, connector	94*-KX	--	--	--
11	10065	CABLE STRAP	94*-KX	--	--	--
12	72039-71	PIN, single socket (2)	94*-KX	--	--	--
13	72055-94	CONNECTOR, two pin	94*-KX	--	--	--
14	70654-86	BOOT, switch	94*-KX	--	--	--
15	76192-92	AMPLIFIER	93-KX	--	--	--
	76192-94	AMPLIFIER includes the following:	94*-KX	--	--	--
11	10065	CABLE STRAP	94*-KX	--	--	--
16	72159-94	SOCKET LOCK, sec. 12-way	94*-KX	--	--	--
17	72195-94	SEAL PIN	94*-KX	--	--	--
18	76299-89	SWITCH, function control/volume	93-KX	--	--	--
	76299-94	SWITCH, function control/volume	94*-KX	--	--	--
19	77029-86A	SPEAKER (2)	93*-KX	--	--	--
20	77032-89	WIRING HARNESS, intercom	93*-KX	--	--	--
21	88403-93	WIRING HARNESS, cycle to sidecar	93-KX	--	--	--
	88403-94	WIRING HARNESS, audio	94*-KX	--	--	--
22	88404-93	WIRING HARNESS, amplifier to speakers	93-KX	--	--	--
23	91808-89	ELEMENT, lighter	93*-KX	--	--	--
24	91812-89	SOCKET, lighter	93*-KX	--	--	--

FLT MODELS

TLE GX
TLE-ULTRA KX

FXR MODELS

RLE HX

**CALIFORNIA EVAPORATIVE
EMISSIONS KIT**

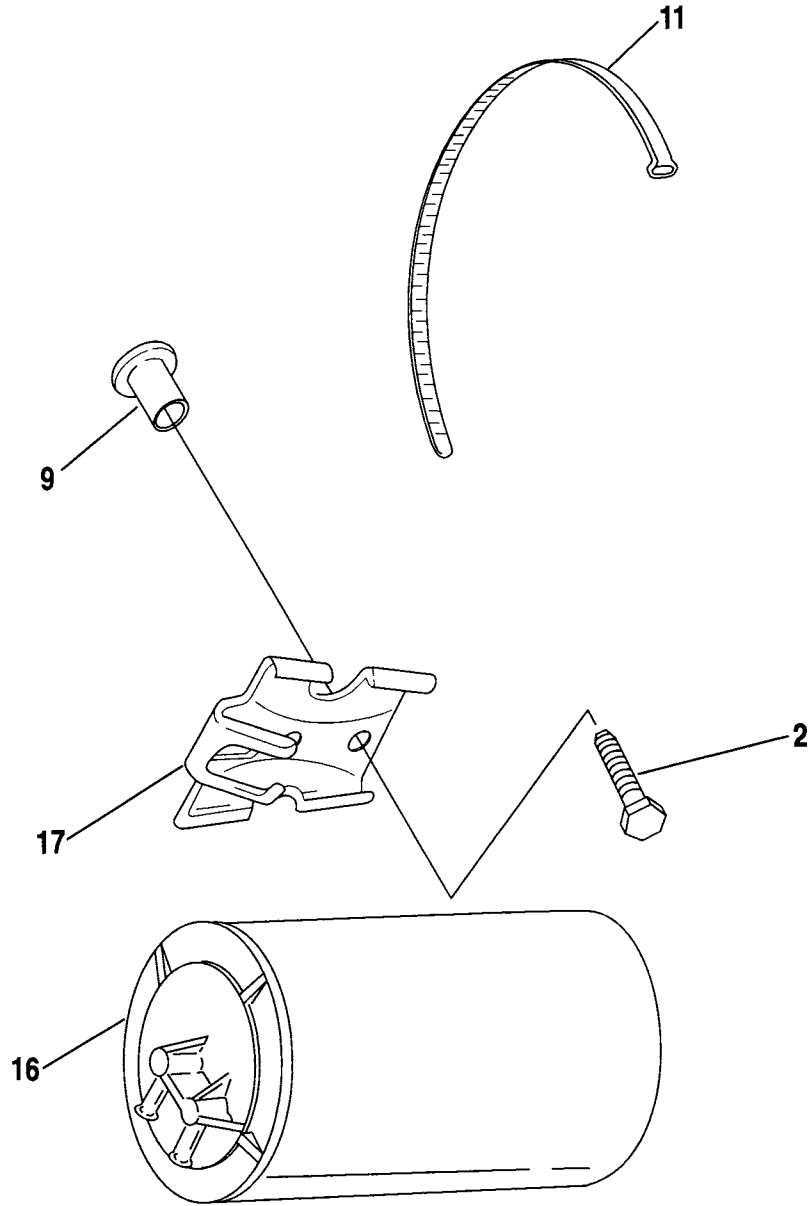

INDEX NO.	PART NO.	DESCRIPTION	FLT MODELS	FXR MODELS	SOFTAIL MODELS	DYNA MODELS
NOTE: These kits are for 1993 & later 1340 cc model motorcycles in the state of California.						
2	3473	SCREW	93*-ALL	--	--	--
	3574	SCREW (4; 2 - Softail)	--	93-ALL	93*-ALL	--
	3579	SCREW	--	93-ALL	--	--
	3588	SCREW (4)	--	93*-ALL	--	--
	3739	SCREW	--	93-ALL	--	--
	4091	SCREW	93*-ALL	--	--	--
9	7102	LOCKWASHER	93*-ALL	--	--	--
	7629	NUT, keps	93*-ALL	--	--	--
	8099	WELL NUT (2)	--	--	93*-ALL	--
11	9988	CLAMP	--	--	93*-ALL	--
	10006	CABLE STRAP (3)	93*-ALL	--	--	93*-ALL
	10039	CABLE STRAP	--	--	93*-ALL	--
	10073	CABLE STRAP	93*-ALL	--	--	--
	10113	CLIP, double hose (3)	--	93*-ALL	--	--
	27014-93A	HOSE KIT, cannister to bracket	93*-ALL	--	--	--
	27030-93	BRACKET, hold down	93*-ALL	--	--	--
	27037-91	HOSE, bracket to air cleaner	93*-ALL	--	--	--
	27042-84	CANNISTER ASM.	93*-ALL	93*-ALL	93*-ALL	93*-ALL
	27047-84	CANNISTER BRACKET	--	93*-ALL	93*-ALL	--
16	27078-91	FITTING, cannister	E93-ALL	--	--	--
	27082-91	FITTING, cannister	E93-ALL	--	--	--
	27189-92	TUBE, tank to cannister	--	--	--	93*-ALL
	27190-90A	TUBE, cannister to carburetor	--	--	--	93*-ALL
	27192-92	BRACKET, cannister asm.	--	93*-ALL	--	--
	27195-92	HOSE, cannister	--	93*-ALL	--	--
	27297-93	TUBE, valve to cannister	93*-ALL	--	--	--
	27298-93	TUBE, carburetor to carburetor	93*-ALL	--	--	--
	27299-93	HOSE, carburetor to valve	93*-ALL	--	--	--
	28884-92	EVAP. TUBE ASM.	--	--	93*-ALL	93*-ALL
17	28886-90	UPTUBE ASM.	--	--	--	93*-ALL
	29306-92	CONNECTOR, evap.	--	--	93*-ALL	--
	67239-83	CLIP, cable guide	--	--	93*-ALL	--
	70933-90	PROTECTIVE TAPE	--	--	93*-ALL	--

NOTE: Hose is sold in bulk length under the following part numbers. Cut to length.

26571-89	HOSE, 7/32" I.D. x 7/16" O.D. (rubber) (10 ft. lg.)--	--	93*-ALL	--
27138-90	HOSE, 3/16" I.D. x 11/32" O.D. (rubber)(10 ft. lg.)--	93*-ALL	93*-ALL	--

FLT MODELS

FLHTC DJ
 FLTC-U DM
 FLHTC-U DP
 FLHS FA

FXR MODELS

FXR EA
 FXRS-SP EG
 FXLR EL
 FXRS-CON EM

SOFTAIL MODELS

FLSTC BJ
 FXSTC BK
 FXSTS BL
 FLSTF BM
 FLSTN BN

DYNA MODELS

FXDL GD
 FXDWG GE

GLOSSARY

A		L	
ADJ.....	Adjuster	L.....	Left
ARM.....	Armature	LG.....	Long
AS REQ'D.....	As Required	LT.....	Light
ASM.....	Assembly	LVR.....	Lever
B		M	
BK.....	Black	MAINSFT.....	Mainshaft
BK.....	Brake	MM.....	Millimeter
BLK.....	Black	MPH.....	Miles Per Hour
BLK.....	Block	MTG.....	Mounting
BLU.....	Blue	N	
BRG.....	Bearing	NEG.....	Negative
BRKR.....	Breaker	NEUT.....	Neutral
BRKT.....	Bracket	NO.....	Number
BRTHR.....	Breather	O	
BSHG.....	Bushing	O.S.....	Over Size
BTRY.....	Battery	OIL PMP.....	Oil Pump
C		ORN.....	Orange
CARB.....	Carburetor	P	
CB.....	Circuit Breaker	P.D.....	Pitch Diameter
CKT.....	Circuit	PASS.....	Passenger
CL.....	Clutch	PIN.....	Pinion
CLNR.....	Cleaner	PLSTC.....	Plastic
CLPR.....	Caliper	POS.....	Positive
COMM.....	Commutator	PRI.....	Primary
COMP.....	Complete	R	
COMPL.....	Complete	R.....	Right
CONN.....	Connecting	RLSE.....	Release
COV.....	Cover	RLY.....	Relay
CRKC.....	Crankcase	RR.....	Rear
CTSHFT.....	Countershaft	S	
CYL.....	Cylinder	SCR.....	Screw
D		SFT.....	Shaft
DR.....	Door	SHF.....	Shift
DR.....	Drive	SIG.....	Signal
E		SOL.....	Solenoid
EXH.....	Exhaust	SPCR.....	Spacer
F		SPEEDO.....	Speedometer
FR.....	Front	SPRKT.....	Sprocket
FT.....	Foot	START.....	Starter
G		STD.....	Standard
GND.....	Ground	SW.....	Switch
GRN.....	Green	T	
H		T.....	Teeth
HD.....	Head	THK.....	Thick
HDLBR.....	Handlebar	THROT.....	Throttle
HDLMP.....	Headlamp	TURN SIG.....	Turn Signal
HTM.....	High Temperature	V	
I		V.....	Volt
I.D.....	Inside Diameter	V.....	Valve
IGN.....	Ignition	W	
ILLUS.....	Illustration	W/.....	With
INSTR.....	Instruments	WHT.....	White
INT.....	Intake	WRKL.....	Wrinkle
INT.....	Internal	WRN.....	Warning
K		Y	
KPH.....	Kilometers Per Hour	YEL.....	Yellow

HARDWARE LISTING

813A	SCREW, 1/4-20 X 1-3/4 knurled socket hd. (chrome)	2337W	SCREW, 1/4-20 X 1/2 pan hd. (self-lock)
853A	SCREW, 5/16-18 X 2-1/4 knurled socket hd.	2420	SCREW, 1/4-20 X 3/4 Pozidriv truss hd. (Grade 2 steel)
854A	SCREW, 5/16-18 X 2-1/4 socket hd. (Grade 2 steel)	2430	SCREW, No. 12-24 X 7/8 knurled socket hd.
855B	SCREW, 3/8-16 X 2 knurled socket hd.	2432	SCREW, No. 12-24 X 7/8 Phillips truss hd. (black)
856A	SCREW, 5/16-24 X 1 knurled socket hd.	2443	SCREW, No. 10-24 X 3/8 cross recess oval hd. (Grade 2 steel)
861A	SCREW, 3/8-16 X 1 knurled socket hd.(Grade 8 steel)	2524	SCREW, No. 10-24 X 3/8 oval hd.
868	SCREW, 1/2-13 X 1/2 socket button hd.	2501	SCREW, No. 8-32 X 3/8 socket hd. (self-tapping)
872A	SCREW, 1/2-20 X 3-1/4 knurled socket hd.	2504	SCREW, No. 10-16 X 1-1/8 Pozidriv oval ctsk. hd. (self-tapping)
882	SCREW, 1/4-20 X 7/8 knurled socket hd. (Grade 8 steel)	2508	SCREW, No. 10-32 X 1/2 socket rd. hd. (black)
891	SCREW, 1/4-20 X 1-3/4 socket hd. (Grade 8 steel)	2513	SCREW, 1/4-20 X 1-1/4 socket rd. hd. (black)
907	SCREW, No. 10-32 X 7/16 Pozidriv fillister hd. (w/lockpatch)(Grade 2 steel)	2519	SCREW, 1/4-20 X 1-1/2 Socket button hd. (black)
909	SCREW, No. 10-24 X 1-1/4 Pozidriv pan hd. (w/lockpatch)(Grade 2 steel)	2523	SCREW, No. 8-32 X 1/2 hex washer hd. (self-tapping)
919	SCREW, 1/4-28 X 3/4 socket hd.	2524	SCREW, 5/16 X 1/2 hex button hd. (self-tapping) (Grade 8 steel)
922	SCREW, No. 6-32 X 3/4 Phillips hd. (black)	2531	SCREW, No. 4-40 X 5/16 Pozidriv pan hd. (Grade 2 steel)
923	SCREW, 1/4-20 X 21/32 socket pan hd.	2538	SCREW, 1/4-20 X 1 Pozidriv pan hd. (Grade 2 steel)
924	SCREW, 1/4-20 X 33/64 socket pan hd.	2551W	BOLT, 1/4-20 X 1 hex. hd. (Grade 5 steel)
925	SCREW, 1/4-28 X 5/8 socket button hd.	2574WA	SCREW, No. 6-32 X 1/4 oval hd.(w/ lockwasher)
927A	SCREW, 1/4-20 X 3/4 button hd. (grade 8 steel)	2576	SCREW, No. 10-32 X 3/4 Pan Hd.(Grade 2 steel)
932	SCREW, 1/4-20 X 1/2 truss hd. (chrome)	2579	SCREW, No. 8-32 X 5/8 Pozidriv oval ctsk. hd. (Grade 2 steel)
933	SCREW, No. 10-32 X 15/16 Pozidriv truss hd. (Grade 2 steel)	2582	SCREW, 5/16-18 X 3/4 Pozidriv pan hd. (Grade 2 steel)
939	SCREW, 1/4-20 X 1 w/washer (Grade 2 steel) (self tapping)	2585	SCREW, No. 8-32 X 5/16 Pozidriv pan hd. (Grade 2 steel)
1046	SCREW, #8 X 5/16 fillester hd. (self-tapping)	2592	SCREW, No. 10-24 X 1/2 Pozidriv pan hd. (Grade 2 steel)
1203	SCREW, No. 8-32 X 7/8 Pozidriv fillister hd. (Grade 2 steel)	2594A	SCREW, No. 8-32 X 1/4 Pozidriv pan hd. (w/ lockwasher)(Grade 2 steel)
1309B	SCREW, No. 10-32 X 1/2 Phillips truss hd. (self-sealing)	2602	SCREW, 1/4-20 X 1-1/4 Pozidriv pan hd. (Grade 2 steel)
1311A	SCREW, No. 8-32 X 1/2 Phillips truss hd. (self-sealing)	2604	SCREW, No. 10-32 X 1/2 Pozidriv pan hd. (Grade 2 steel)
1357W	SCREW, 1/4-20 X 1 Phillips oval ctsk. hd. (stainless)	2607	SCREW, 1/4-20 X 3/4 Pozidriv pan hd. (Grade 2 steel)
1601	SCREW, No. 8-32 X 1/2 Pozidriv flat ctsk. hd. (Grade 2 steel)	2611B	BOLT, No. 10-32 X 3/4 hex. washer hd. (Grade 5 steel)
1602	SCREW, 1/4-20 X 3/4 flat hd. (Grade 2 steel)	2614	BOLT, 1/4-28 X 2 hex. hd. (Grade 5 steel)
1610	SCREW, 5/16-24 X 1-1/2 Pozidriv flat ctsk. hd. (Grade 2 steel)	2623W	SCREW, No. 8-15 X 5/8 pan hd. (self-tapping) (Grade 1 steel)
1643	SCREW, 7/16-14 X 1-1/4 flat socket ctsk. hd. (w/lockpatch)	2646	SCREW, No. 8-32 X 3/4 Pozidriv pan hd. (Grade 2 steel)
1719W	SCREW, No. 8-32 X 5/8 Phillips truss hd.	2647B	SCREW, No. 10-24 X 3/4 hex. socket (locking) (Grade 8 steel)
1783	SCREW, 5/16-18 X 7/8 Pozidriv flat ctsk. hd. (Grade 2 steel)	2648	SCREW, 1/4-20 X 1 Pozidriv truss hd. (Grade 2 steel)
2005	SCREW, 3/8-24 X 15/16 Pozidriv oval ctsk. hd. (Grade 2 steel)(chrome)		
2216W	SCREW, No. 4-24 X 1/2 Phillips oval ctsk. hd. (self-tapping)		

HARDWARE LISTING

2664	SCREW, No. 10-24 X 7/16 Pozidriv pan hd. (Grade 2 steel)	2907	SCREW, M3 X .05 X 8mm cross recess pan hd. (self-tapping)
2665	SCREW, No. 10-24 X 5/8 Pozidriv pan hd. (Grade 2 steel)	2908	SCREW, M3 X .05 X 12mm cross recess pan hd. (self-tapping)
2667	BOLT, 5/16-18 X 2 hex. hd. (Grade 5 steel)	2909	SCREW, M3 X .05 X 25mm cross recess pan hd. (self-tapping)
2692WA	SCREW, No. 10-24 X 1/2 socket fillis. hd.	2910	SCREW, M3 X 1.058 X 8mm cross recess pan hd. (self-tapping)
2698A	SCREW, 5/16-18 X 9/16 socket fillis. hd.	2917	SCREW, 3/8-16 X 3/4 knurled socket hd. (Grade 8 steel)
2708A	SCREW, 5/16-18 X 1 socket hd.	3201WA	SCREW, 5/16-18 X 1-1/4 knurled soc. hd.
2711	SCREW, No. 4-40 X 3/8 pan hd. (self-tapping)	3210A	SCREW, 5/16-18 X 1-1/4 knurled soc. hd.
2720	SCREW, No. 10-24 X 1 Torx hd. (w/ locking adhesive)	3214	SCREW, 3/8-16 X 1-1/4 socket hd. (thd. cutting)
2724	SCREW, No. 10-16 X 1/2 (Grade 2 steel) (chrome)	3224	SCREW, 5/16-24 X 2-3/4 knurled socket hd.(Grade 8 steel)
2725	SCREW, No. 12-24 X 5/8 Phillips rd. hd.	3233	SET SCREW, 1/4-28 X 1/4 socket hd.
2726A	SCREW, No. 12-24 X 21/32 Phillips truss hd. (chrome)	3234W	SET SCREW, 1/4-20 X 5/16 slot hd.
2731W	SCREW, No. 10 X 3/8 Phillips truss hd. (self-tapping)	3255	SCREW, 1/4 X 5/8 knurled socket hd.(Grade 8 steel)(tapping)
2733	SCREW, 1/4-28 X 1/2 slotted rd. hd. (w/lockwasher)(chrome)	3403	LOCKNUT, M8 X 7 X 12mm hex.
2739	SCREW, 1/4-28 X 1/2 Phillips truss hd. (w/lockwasher)(chrome)	3409	BOLT, 5/16-24 X 3-1/2 hex. hd. (Grade 5 steel)
2773	SCREW, 1/4-20 X 1/2 Pozidriv pan hd. (Grade 2 steel)	3419	BOLT, 5/16-18 X 2-1/4 hex. hd. (Grade 5 steel)
2774	SCREW, 1/4-20 X 5/8 Pozidriv pan hd. (Grade 2 steel)	3427	BOLT, 5/16-18 X 3-1/2 hex. hd. (Grade 5 steel)
2782	SCREW, 5/16-18 X 1/2 cross recess truss hd. (Grade 2 steel)	3430	BOLT, 5/16-24 X 5 hex. hd. (Grade 5 steel)
2784	SCREW, 5/16-18 X 7/8 Pozidriv truss hd. (Grade 2 steel)	3440	BOLT, 3/8-16 X 1/2 hex. hd. (Grade 5 steel)
2787	SCREW, 5mm-.8 pt. X 10mm pan hd. (Grade 2 steel)	3444A	SCREW, 1/4-20 X 5/8 socket fillis. hd. (w/lockpatch)
2796W	SCREW, 1/4-20 X 1-1/2 hex. slot hd. (w/lockpatch)	3445	BOLT, 5/16-18 X 9/16 hex. hd. (w/lockpatch) (Grade 5 steel)
2804W	SCREW, No. 6-32 X 1/2 Pozidriv pan hd.	3450	BOLT, 1/2-13 X 2-1/2 hex. hd. (Grade 5 steel)
2806	SCREW, No. 6-32 X 3/4 Pozidriv pan hd. (Grade 2 steel)	3462	BOLT, 5/16-18 X 1-1/4 hex. hd. (Grade 8 steel)
2818	BOLT, 5/16-18 X 1-1/2 hex. hd. (Grade 5 steel)	3464	BOLT, 3/8-16 X 3/4 hex. hd. (Grade 8 steel)
2823	SCREW, 5/16-24 X 3/8 Pozidriv truss hd. (w/lockwasher)(Grade 2 steel)	3471	BOLT, 1/2-13 X 2-3/4 hex. hd. (Grade 5 steel)
2824W	SCREW, 5/16-24 X 9/16 Phillips hd.	3473	BOLT, No. 10-32 X 1/2 hex. washer hd. Grade 2 steel)
2831	SCREW, No. 6-32 X 3/8 Pozidriv truss hd. (Grade 2 steel)	3480A	SCREW, 1/4-20 X 1-3/4 knurled socket hd. (Grade 8 steel)
2851	BOLT, 3/8-16 X 7/8 hex. hd. (Grade 5 steel)	3482A	SCREW, 1/4-20 X 1-1/4 knurled socket hd. (Grade 8 steel)
2871W	BOLT, 5/16-18 X 1-1/4 hex. hd. (Grade 5 steel)	3485A	SCREW, 5/16-18 X 1-3/4 knurled socket hd. (Grade 8 steel)
2879W	BOLT, 3/8-16 X 1 hex. hd. (Grade 5 steel)	3486	BOLT, 1/2-20 X 1-1/4 hex. hd.
2882W	BOLT, 5/16-18 X 5/8 hex. hd. (Grade 5 steel)	3487	BOLT, 5/16-24 X 5/8 hex. locking hd.
2888	SCREW, No. 8-32 X 1/2 Pozidriv truss hd. (Grade 2 steel)	3494A	BOLT, 5/16-18 X 7/8 hex. hd.
2889	BOLT, 3/8-24 X 3/4 hex. hd. (Grade 5 steel)	3500	BOLT, 5/16-18 X 2-3/4 hex. hd.(Grade 8 steel)
2904A	SCREW, 3/8-24 X 3/4 socket hd.	3501	BOLT, 5/16-18 X 2-1/2 hex. hd.(Grade 8 steel)
2906	BOLT, 3/8-16 X 7/8 hex. hd (w/lockpatch) (Grade 5 steel)	3503	BOLT, 3/8-24 X 2 hex. hd.(Grade 8 steel)
		3504	BOLT, 5/16-24 X 5-3/8 hex. hd.(Grade 5 steel)
		3506	STUD, 5/16-24 X 5-3/4 hex. hd.(Grade 5 steel)
		3509	BOLT, 3/8-16 X 2-3/4 hex. hd.(Grade 8 steel)
		3512	BOLT, 3/8-24 X 3-1/4 hex. hd. (chrome)
		3514	SCREW, No. 8-32 X 1 fillister hd.

HARDWARE LISTING

3516A	SCREW, 1/2-20 X 1-1/4 knurled socket hd. (Grade 8 steel)	3739	SCREW, 1/4 X 5/8 hex. washer. hd. (self-tapping)
3528	BOLT, 3/8-16 X 3-1/4 hex hd.(Grade 8 steel)	3764	BOLT, 7/16-14 X 2 hex. hd. (Grade 5 steel)
3529	SCREW, No. 10-32 X 1/4 slot hex washer hd. (self-tapping)	3767B	BOLT, 1/4-20 X 5/8 hex. hd.(Grade 5 steel)
3530	SCREW, 5/16-18 X 3-3/4 hex. hd. (Grade 5 steel)	3769	BOLT, 7/16-14 X 1-1/2 hex. hd. (Grade 5 steel)
3531A	SCREW, 5/16-18 X 3/8 knurled socket hd. (Grade 8 steel)	3770	SCREW, 1/4-20 X 7/8 12 pt. hd.(Grade 5 steel)
3533	SCREW, 5/16-24 X 3/8 socket button hd.	3782	BOLT, 7/16-14 X 1-1/4 hex. hd. (Grade 5 steel)
3535	BOLT, 1/2-20 X 2 hex. hd.(chrome)	3784	SET SCREW, 1/2-20 X 1/2 socket hd. (w/lockpatch)
3536	BOLT, 3/8-16 X 1-1/4 hex hd.(Grade 8 steel)	3787	BOLT, 1/4-20 X 3/4 hex. hd.(Grade 5 steel)
3537	SCREW, 1/4-28 X 1/2. flange lock	3826	BOLT, 1/4-28 X 1-1/4 hex. hd.(Grade 5 steel)
3538	SCREW, 5/16-24 X 1/2 hex. socket button hd.	3945	BOLT, 3/8-24 X 2-1/4 hex. hd.(Grade 5 steel)
3540	SCREW, 5/16-18 X 5/8 hex. soc. button hd.	3946	BOLT, 7/16-20 X 2 hex. hd.(Grade 5 steel)
3541	BOLT, No. 10-24 X 5/8 hex. hd. (Grade 2 steel)	3949	BOLT, 1/2-13 X 2-1/2 hex. hd. (Grade 5 steel)
3546	BOLT, 5/16-18 X 5/8 hex. hd. (flange lock)	3953W	BOLT, 5/16-24 X 1/2 hex. hd.(Grade 5 steel)
3548A	SCREW, No. 8-32 X 1-1/4 knurled socket hd. (Grade 8 steel)	3958	BOLT, 1/2-20 X 2-1/4 hex. hd.(Grade 5 steel)
3549A	SCREW, 1/2-20 X 1-1/2 knurled socket hd.	3960W	BOLT, 5/16-24 X 1 hex. hd.(Grade 5 steel)
3554	BOLT, 3/8-16 X 1-3/4 hex hd.	3974HW	BOLT, 5/16-24 X 3/4 hex. hd.(Grade 5 steel)
3556A	SCREW, No.8-32 X 1/2 knurled socket hd.	3987	BOLT, 5/16-18 X 3/4 hex. hd.(Grade 5 steel)
3562	SCREW, No.12 X 1/2 hex. washer hd. (self-tapping)	3991	BOLT, 5/16-18 X 7/8 hex. hd.(Grade 5 steel)
3574	SCREW, 1/4-20 X 3/4 hex washer hd.	3993	BOLT, 1/4-20 X 1-1/4 hex. hd.(Grade 5 steel)
3576	SCREW, 5/16-18 X 1/2 hex washer hd.	3996	BOLT, 5/8-24 X 7/8 hex. hd.(Grade 5 steel)
3579	SCREW, 1/2-13 X 5/8 (Grade 2 steel) (self tapping)	3997	BOLT, 1/4-20 X 1-1/4 hex. hd.
3584	SCREW, 5/16-18 X 2-1/2 hex. socket button hd. (Grade 8 steel)	4013	SCREW, 3/8-16 X 7/8 socket pan hd. (Grade 5 steel)
3588	SCREW, 1/4-20 X 1/2 hex. flange hd.	4014W	BOLT, 5/16-24 X 1-1/4 hex. hd.(Grade 5 steel)
3589	SCREW, 5/16-24 X 1-1/4 socket hd. (chrome)	4015	SCREW, 1/4-20 X 7/8 socket rd. hd.(black)
3592	SCREW, No. 8-32 X 1/2 Torx truss hd. (stainless steel)	4016	SCREW, 5/16-18 X 7/8 socket rd. hd.
3594A	SCREW, 1/4-20 X 5/8 knurled socket hd. (Grade 8 steel)	4017	BOLT, 5/16-18 X 1 hex. hd.(Grade 5 steel)
3597	SCREW, No. 6-32 X 9/16 Torx pan hd. (thread cutting)	4020W	BOLT, 5/16-24 X 1-3/8 hex. hd.(Grade 5 steel)
3598	SCREW, No. 6-32 X 3/4 Torx pan hd. (thread cutting)	4029A	SCREW, 3/8-16 X 2-1/4 socket hd.(black)
3599	SCREW, 1/2-13 X 1-1/8 knurled soc. hd. (Grade 8 steel)	4030	SCREW, 3/8-16 X 2-7/16 socket pan hd.
3601	SCREW, 1/4-20 X 1-1/4 knurled socket hd. (Grade 8 steel)	4033	SCREW, 1/4-20 X 1-5/8 hex. soc. button hd.
3602	SCREW, 5/16 X 1/2 hex. hd. (self-tapping)(sems)	4036	BOLT, 5/16-24 X 1-1/2 hex. hd.(Grade 5 steel)
3605	BOLT, 1/2-13 X 2-1/2 hex. hd. (Grade 5 steel)	4041W	SCREW, 5/16-24 X 1-5/8 hex hd.
3606	SCREW, No. 10-24 X 7/8 hex. hd.	4044	SCREW, 3/8-16 X 1 socket button hd.
3607	BOLT, 1/2-13 X 2 hex. hd. (Grade 5 steel)	4045	BOLT, 3/4-10 X 2-3/4 hex. (Grade 8 steel)
3652	SCREW, 1/4-20 X 3/8 socket hd.(chrome)	4046	SCREW, 3/8-24 X 2-7/16 socket button hd. (Grade 8 steel)
3655	SCREW, 5/16-18 X 7/8 pan hd.	4052	BOLT, 1/2-13 X 1-3/4 hex. (Grade 5 steel)
3656	SCREW, No. 8-32 X 3/8 Torx pan hd. (Grade 5 steel)	4059	SCREW, 3/8-16 X 1 Torx hd. (Grade 8 steel) (tapping w/ lockpatch)
3730A	BOLT, 7/16-14 X 1-3/4 hex. hd. (Grade 8 steel)	4061	BOLT, 5/16-18 X 5 hex. hd.(Grade 5 steel)
		4068	BOLT, 5/16-18 X 1-7/8 hex. hd.(Grade 5 steel)
		4069A	SCREW, 1/4-20 X 3/4 knurled socket hd.
		4074	BOLT, 1/2-13 X 2 hex. hd. shoulder
		4081	BOLT, 1/2-20 X 1-3/4 hex. hd. (Grade 5 steel)
		4086	BOLT, 5/16-18 X 3 hex. hd.(Grade 5 steel)
		4091	BOLT, No. 10-24 X 1/2 hex. washer hd. (self-tapping)
		4095	SCREW, 5/16-24 X 7/16 socket hd. (w/lockpatch)
		4098	SCREW, 3/8-16 X 1-1/4 socket button hd. (Grade 8 steel)

HARDWARE LISTING

4100HW	BOLT, 5/16-18 X 4 hex. hd.(Grade 5 steel)	4813A	SCREW, 1/4-20 X 1-3/8 knurled socket hd. (w/lockpatch)
4319	BOLT, 3/8-24 X 1 hex. hd.(Grade 5 steel)	4814A	SCREW, 1/4-20 X 1-1/8 knurled socket hd. (w/lockpatch)
4325	BOLT, 1/4-20 X 5-1/2 hex hd.(Grade 8 steel)	4816A	SCREW,5/16-18 X 1-1/2 socket hd.
4326A	SCREW, 5/16-18 X 2 hex. soc. hd.	4820A	SCREW, 1/4-20 X 2 hex. socket
4327	SCREW, 5/16-18 X 2 hex. soc. hd.	4822A	SCREW, 1/4-20 X 2-3/4 knurled socket hd. (w/lockpatch)
4328	SCREW, 5/16 X 3/4 hex. washer hd. (self-tapping)	4961	BOLT, 3/4-16 X 1-5/8 hex. hd.(Grade 5 steel)
4329	SCREW, 1/4-20 X 3/4 hex. washer hd. (self-tapping)	5209	SCREW, No. 12-16 X 5/8 Pozidriv pan hd.
4337W	BOLT, 3/8-24 X 1-1/4 hex. hd.(Grade 5 steel)	5403B	CARRIAGE BOLT, 1/4-20 X 3/8
4350A	SCREW, 3/8-16 X 1-1/2 hex. soc. hd.	5414	CARRIAGE BOLT, 3/8-16 X 7/8 (Grade 5 steel)
4351	SCREW, 5/16 X 3/4 Torx hd. (self-tapping) (Grade 8 steel)	5415	CARRIAGE BOLT, 3/8-16 X 2 (Grade 5 steel)
4352	SCREW, 3/8-16 X 1-1/2 Torx (self-tapping) (Grade 8 steel)	5444	CARRIAGE BOLT, 3/8-16 X 1(Grade 5 steel)
4355A	SCREW, 3/8-16 X 1-3/4 knurled socket hd.	5445W	BOLT, 5/16 X 1-1/4 carriage bolt (Grade 5 steel)
4356	SCREW, 3/8-16 X 1-1/2 knurled socket hd. (Grade 8 steel)	5465	CARRIAGE BOLT, No. 10-24 X 1/2
4357	SCREW, 3/8-16 X 1-3/4 knurled socket hd. (Grade 8 steel)	6003	WASHER, 1-3/16 X 1-3/8 X 5/64
4383	SCREW, 5/16-18 X 5/8 washer (Grade 2 steel)	6007	WASHER, 5/8 X 5/16 X 3/32(nylon)
4384	SCREW, 5/16-18 X 1 hex washer hd. (self-threading)	6012	WASHER, 1/2 X 1-3/16 X 1/16
4401W	BOLT, 3/8-24 X 2-3/4 hex. hd.(Grade 5 steel)	6016	WASHER, 11/32 X 11/16 X 1/16
4411	BOLT, 3/8-24 X 1-3/4 hex. hd.(Grade 5 steel)	6019	WASHER, 3/8 X 29/32 X 1/16
4412	BOLT, 3/8-24 X 2-1/2 hex. hd.(Grade 5 steel)	6035	WASHER, 1/4 X 1-1/4 X 1/8 (neoprene)
4416	BOLT, 3/8-24 X 1 hex. hd.(Grade 5 steel)	6036	WASHER, 17/64 X 1 X 1/16
4435W	BOLT, 3/8-24 X 3-1/2 hex. hd.(Grade 5 steel)	6040	WASHER, 3/4 X 1-1/2 X 1/16
4453	BOLT, 1/4-20 X 7/8 hex. hd.	6047	WASHER, 5/8 X 13/64 X 3/64
4460	BOLT, 5/8-18 X 1 hex. hd.(Grade 5 steel)	6053	WASHER, 3/16 X 7/16 X 1/16 (nylon) (black)
4701	BOLT, 5/16-24 X 1-1/2 hex. hd.(Grade 5 steel)	6054	WASHER, 3/16 X 9/16 X 1/16 (nylon) (black)
4702	BOLT, 1/4-20 X 3/4 hex. (Grade 5 steel)	6057	WASHER, 1/2 X 7/8 X 3/16 (nylon)
4713W	BOLT, 3/8-16 X 3/4 hex. hd.(Grade 5 steel)	6099	WASHER, 1/4 X 7/16 X 1/16
4716W	BOLT, 3/8-16 X 1-1/4 hex. hd.(Grade 5 steel)	6107B	WASHER, 5/16 X 11/16 X 1/8
4717A	SCREW, 1/4-20 X 2-1/4 knurled socket hd. (w/lockpatch)	6109	WASHER, 5/16 X 11/16 X 1/8
4718A	SCREW, 1/4-20 X 1-1/2 knurled socket hd. (w/lockpatch)	6113	WASHER, 1/2 X 13/16 X 1/32
4719W	BOLT, 3/8-16 X 2-1/2 hex. hd.(Grade 5 steel)	6127	WASHER, 13/32 X 13/16 X 5/64
4721	BOLT, 3/8-16 X 1-1/2 hex. hd.(Grade 5 steel)	6150W	WASHER, 3/16 X 3/8 X 1/16
4722	BOLT, 3/8-16 X 2-1/4 hex. hd.(Grade 5 steel)	6192	WASHER, No. 8 X 7/16 X 3/64
4724	BOLT, 3/8-24 X 1-1/2 hex. hd.(Grade 5 steel)	6220W	WASHER, 1/4 X 7/16 X 1/32
4726	BOLT, 7/16-20 X 1-1/2 hex. hd.(Grade 5 steel)	6235	WASHER, 1/4 X 23/32 X 1/16
4729	BOLT, 7/16-20 X 1-1/4 hex. hd.(Grade 5 steel)	6237	WASHER, 5/16 X 1-1/8 X 5/64
4739A	BOLT, 5/16-18 X 1-3/4 hex. hd. tap	6238	WASHER, 11/32 X 1-1/8 X 5/64
4740A	SCREW, 1/4-20 X 1-1/4 knurled socket hd. (w/lockpatch)	6239	WASHER, 1/4 X 1/2 X 3/32
4741A	SCREW, 1/4-20 X 1 hex. socket hd.(w/lockpatch)	6253W	WASHER, 1/4 X 3/4 X 3/64
4742A	SCREW, 1/4-20 X 2-1/4 knurled socket hd. (w/lockpatch)	6265	WASHER, 1/4 X 3/4 X 3/64
4747	SCREW, 3/8-16 X 2-5/8 knurled socket hd. (Grade 8 steel)	6314W	WASHER, 21/64 X 9/16 X 1/8
		6333	WASHER, 5/16 X 7/8 X 5/64
		6334	WASHER, 7/16 X 29/32 X 1/16
		6335	WASHER, No. 4 X 5/16 X 1/32
		6352	WASHER, 5/16 X 7/8 X 3/32 (chrome)
		6353	WASHER, 3/8 X 13/16 X 1/16 (chrome)
		6365	WASHER, 17/32 X 1-1/8 X 5/64
		6366	WASHER, 1/2 X 1-1/4 X 3/32
		6371	WASHER, 25/64 X 1 X 3/32
		6379W	WASHER, 3/8 X 5/8 X 3/64

HARDWARE LISTING

6398	WASHER, 3/8 X 13/16 X 3/32 (rubber)	7045	LOCKWASHER, 3/8(high collar)
6400HB	WASHER, 5/16 X 13/16 X 3/32	7068	LOCKWASHER, 1/2
6409	WASHER, 1/2 X 3/4 X 1/32 (plastic)	7069	LOCKWASHER, No. 10
6410	WASHER, 1/4 X 9/16 X 1/16 (nylon)	7100	LOCKWASHER, 5/16 internal/external tooth
6416	WASHER, 3/8 X 1 X 5/64	7101	LOCKWASHER, 3/8 internal/external tooth
6474	WASHER, 3/8 X 13/16 X 5/32	7102	LOCKWASHER, #10 internal/external tooth
6497HW	WASHER, 7/16 X 1-1/8 X 3/64	7115	LOCKWASHER, No. 8 internal tooth
6498	WASHER, 9/16 X 13/16 X 1/32 (nylon)	7118	LOCKWASHER, No. 10 internal tooth
6506	WASHER, 1-13/32 X 2-3/32 X 1/16 (bronze)	7124	LOCKWASHER, 1/4 internal tooth
6516HW	WASHER, 7/16 X 1-1/8 X 1/8	7127	LOCKWASHER, 5/16 internal tooth
6519	WASHER, 13/32 X 1-1/32 X 1/8	7128	LOCKWASHER, 9/32 internal tooth
6530	WASHER, 1/2 X 1 X 3/16	7129	LOCKWASHER, 1/2 internal tooth
6590HW	WASHER, 1/2 X 1-1/8 X 3/32	7130W	LOCKWASHER, 3/8 internal tooth
6639	WASHER, 5/8 X 1-5/16 X 3/32 (chrome)	7142	LOCKWASHER, 3/4 internal tooth
6645	WASHER, 11/32 X 1-1/32 X 1/8	7145W	LOCKWASHER, 3/8 external tooth
6653	WASHER, 5/8 X 1-5/16 X 3/32	7220	LOCKWASHER, No. 10 external tooth
6655	WASHER, 5/8 X 1-1/2 X 3/32	7229W	LOCKWASHER, 1/4 internal/external tooth
6700B	WASHER, 5/8 X 13/16 X 1/32	7230	LOCKWASHER, 1/4 external tooth
6701	WASHER, 3/8 X 13/16 X 1/16	7232	LOCKWASHER, 5/16 external tooth
6702	WASHER, 5/16 X 11/16 X 1/16	7234	LOCKWASHER, No.10 external tooth
6703	WASHER, 1/4 X 5/8 X 1 /16	7415A	WASHER, 11/32 X 7/8 X 1/8(rubber)
6712B	WASHER, 5/8 X 15/16 X 3/32	7501	SPEED NUT, 1/4 dia. stud size(self threading)
6716	WASHER, No. 10 X 1/2 X 3/64	7506	NUT, No. 4-48 X 3/32 X 1/4 hex.(Grade 2 steel)
6717	WASHER, No. 6 X 3/8 X 3/64	7507	ACORN NUT, 5/16-18 X 11/16 X 1/2 hex. (Grade 2 steel)(chrome)
6718	WASHER, 1/2 X 1-1/16 X 3/32	7515	JAM NUT, 7/16 X 1/4 X 11/16(Grade 2 steel)
6723	WASHER, 17/32 X 1-1/2 X 9/64	7520	ACORN NUT, No. 6-32 X 1/4 X 1/4 hex.(nylon)
6724	WASHER, 21/32 X 1-1/16 X 1/16	7531	FLANGE LOCKNUT, 5/16-18 X 9/32 X 1/2 hex.
6736	WASHER, 9/32 X 5/8 X 1/16	7549A	ACORN NUT, 5/16-18 X 9/16 X 1/2 hex.
6737	WASHER, 57/64 X 1-3/64 X 1/32	7554	ACORN LOCKNUT, 1/2-13
6738	WASHER, 17/32 X 7/8 X 7/64	7576	FLANGE NUT, 3/8-16 X 9/16 hex (keps)
6753	WASHER, 1/2 X 1-1/4 X 1/8 (notched)	7590	NUT, No. 6-32 X 1/8 X 5/16 hex.(Grade 2 steel)
6756	WASHER, 1/2 X 1-1/16 X 3/32	7593	FLANGE NUT, 5/16-24
6758	WASHER, 3/8 X 37/64 X 7/64	7594	LOCKNUT, 5/16-18 X 1/2 (nylon locking)
6762B	WASHER, 11/16 X 29/32 X 1/32	7596	LOCKNUT, 7/16-20
6771A	WASHER, 21/64 X 33/64 X 1/16	7598	HEX NUT, 3/4-10
6781	WASHER, 5/16 X 37/64 X 5/64	7600	HEX NUT, No. 4-40 (keps)
6812	WASHER, 13/32 X 11/16 X 1/16	7601	FLANGE LOCKNUT, 3/8-16
6960	WASHER, 1/2 X 3/4 X .004	7602	ACORN NUT, No. 10-32 X 5/16 X 23/64 hex. (nylon-locking)
6961	WASHER, 1/2 X 3/4 X .007	7606	LOCKNUT, No. 8-32 X 1/4 X 1/4 hex.(chrome)
6962	WASHER, 1/2 X 3/4 X .015	7608	NUT, No. 8-32 X 1/8 X 11/32 hex.(Grade 2 steel)
6963	WASHER, 1/2 X 3/4 X .031	7609W	LOCKNUT, No. 8-32 X 3/16 X 5/16 hex.
6970	WASHER, spring, 1/4 X 1/2 X 1/16	7613A	SPEED NUT, 1/8 dia. stud size
7015	LOCKWASHER, No. 8	7620W	NUT, No. 10-24 X 1/8 X 3/8 hex.(Grade 2 steel)
7017	WASHER, 17/64 X 33/64 X 5/64 (black)	7624	LOCKNUT, No. 10-24 X 1/4 X 3/8 hex.
7018	WASHER, 17/64 X 37/64 X 5/64 (black)	7626W	LOCKNUT, No. 10-32 X 3/16 X 3/8 hex.
7030W	LOCKWASHER, No. 12	7627	ACORN NUT, 1/2-13 X 3/4 hex (chrome)
7036	LOCKWASHER, 1/4	7628	FLANGE LOCKNUT, 3/8-24
7038	LOCKWASHER, 3/8	7629	NUT, No. 10-32 X 3/8 hex (keps)
7039	LOCKWASHER, 7/16	7634	NUT, No. 10-32 X 1/8 X 5/16 hex.(brass)
7041	LOCKWASHER, 5/16	7638	NUT, No. 10-32 X 1/8 X 3/8 hex.(Grade 2 steel)
7042	LOCKWASHER, 5/16 (high collar)		
7043	LOCKWASHER, 3/4		

HARDWARE LISTING

7643W	JAM NUT, 3/8-16 X 7-32 X 9/16 hex.	7833	HEX NUT, 5/16-24
7651	ACORN NUT, No. 12-24 X 3/8 hex	7837W	NUT, 7/16-20 X 3/8 X 11/16 hex.(Grade 2 steel)
7652	NUT, 3/4-16 X 1-1/8 hex.(chrome)	7838	HEX NUT, No. 10-24 (keys)
7653	ACORN NUT, No. 12-24 X 7/16 X 3/8 hex.(black)	7843	HEX NUT, 1/2-13 (slotted)
7654W	NUT, No. 12-24 X 5/32 X 7/16 hex.	7845	HEX NUT, 1/2-20 X 7/16 X 3/4 (Grade 2 steel)
7667	NUT, 3/8-16 X 9/32 X 9/16 hex. (w/nylon insert)	7848W	JAM NUT, 7/16-20 X 1/4 X 11/16 hex. (Grade 2 steel)
7669	TEE NUT, 5/16-18	7855W	JAM NUT, 3/4-16 X 7/16 X 1-1/8 hex. (Grade 2 steel)
7680W	ACORN NUT, 3/8-16 X 25/32 X 9/16 hex. (Grade 2 steel)(chrome)	7862	ACORN NUT, 3/8-16 (locking)(chrome)
7682	LOCKNUT, 1/4-28 X 3/16 X 7/16 hex.	7880	NUT, 1/2-13 X 7/16 X 3/4 hex.(Grade 2 steel)
7683	LOCKNUT, 1/4-28 X 5/16 X 7/16 hex.	7916A	JAM NUT, 5/8-18 (locking)
7686	LOCKNUT, 1/4-20 X 5/16 X 7/16 hex.	7987	CASTLE NUT 5/8-18 X 15/16 hex
7688	NUT, 1/4-20 X 7/32 X 7/16 hex.(Grade 2 steel)	7993	LOCKNUT, 5/8-18 X 15/16 hex.
7689W	JAM NUT, 1/4-20 X 5/32 X 7/16 hex. (Grade 2 steel)	7994	LOCKNUT, 5/8-18 X 15/16 hex
7716	FLANGE LOCKNUT, 1/4-20 X 7/16 hex	8101	SPEED NUT, for 5/16-18 bolt
7725	LOCKNUT, 5/16-24 X 11/32 X 1/2 hex.	8102	SPEED NUT, for 5/16-18 screw
7727	LOCKNUT, 5/16-24 X 1/4 X 1/2 hex.	8107	SPEED NUT, for No. 10-A or Z thread screws
7729	LOCKNUT, 5/16-24 X 1/4 X 1/2 hex.	8108	SPEED NUT, 11/32 dia.
7734W	CASTLE NUT, 1/2-20 X 9/16 X 3/4 hex. (Grade 5 steel)	8126	SPEED NUT, 3/16 dia. stud size
7736	ACORN NUT, 5/16-24 X 19/32 X 1/2 hex. (Grade 2 steel)(chrome)	8131W	LOCKNUT, No. 4-40 X 1/8 X 1/4 hex.
7737W	ACORN NUT, 1/4-20 X 15/32 X 7/16 hex. (Grade 2 steel)	8135B	SPEED NUT, 1/4 dia. stud size
7739	LOCKNUT, 5/16-18 X 11/32 X 1/2 hex.	8155	SPEED NUT, for No. 8-32 screw
7740	LOCKNUT, 5/16-18 X 1/4 X 1/2 hex.		
7742	LOCKNUT, 1/4-20 X 7/32 X 7/16 hex.		
7743	SPEED NUT, for 1/4-20 bolt		
7744	JAM NUT, 5/16-24 X 3/16 X 1/2 hex. (Grade 2 steel)		
7748W	NUT, 5/16-18 X 1/4 X 1/2 hex.(Grade 2 steel)		
7753	NUT, 5/16-24 X 1/4 X 1/2 hex.(Grade 2 steel)		
7763W	JAM NUT, 5/16-18 X 3/16 X 1/2		
7768W	LOCKNUT, 1/2-13 X 19/32 X 3/4 hex.		
7772	LOCKNUT, 5/16-24 X 3/8 Fillster (Grade 2 steel)		
7775	LOCKNUT, 3/8-24 X 7/16 X 9/16 hex.		
7776W	LOCKNUT, 3/8-24 X 9/32 X 9/16 hex.		
7778	LOCKNUT, 3/8-16 X 7/16 X 9/16 hex.		
7780	LOCKNUT, 3/8-24 X 13/32 X 11/16 hex.		
7782	LOCKNUT, 3/8-24 X 3/8 X 9/16 hex. (Grade 8 steel)		
7783	NUT, 3/8-16 X 5/16 X 9/16 hex.(Grade 2 steel)		
7792	NUT, 1/4,-20 X 1/4 hex. (Grade 2 steel)		
7796	NUT, 5/16-18 X 1/4 hex. (Grade 2 steel)		
7800W	NUT, 3/8-24 X 5/16 X 9/16 hex.(Grade 2 steel)		
7823	CASTLE NUT, 5/8-18 X 3/8 X 15/16 hex. (Grade 2 steel)		
7824	LOCKNUT, 1/2-20 X 1/4 hex. (Grade 2 steel)		
7825	LOCKNUT, 7/16-20 X 7/16 X 5/8 hex.		
7827	LOCKNUT, 7/16-14		
7830	HEX NUT, No. 8-32 (keys)		

NUMERICAL INDEX

Part No.	Page	Part No.	Page	Part No.	Page	Part No.	Page	Part No.	Page
10003	3		281	10134	307	11219	11	1357W	133
	33		283	10136	283		17		135
	157		285		285	11241	21	14019-83	167
10006	27		289	10141	277	11244	109		177
	31		293		281		191		185
	157		297	10143	147	11248	37	14027-92	73
	161		299	10147	285	11252	313	14055-84	217
	183		301	1046	91	11400	193	14056-84	217
	221		335		123	11410	143	14101-84	221
	261		339	10998	45		335	14112-88	149
	267		341	11002	21	11411	63	14117-94	309
	289		349	11005	81	11412	115	14121-90	309
	327	10067	233	11016	41	11422	169	14121-94	309
	331	10073	33	11020	47	11428	159	14128-86A	165
	335		289	11067	53	11430	193	14142-86	187
	351		351	11083	41		251	14150-86	103
10007	157	10074	227	11096	53	11437	187	14159-87	189
10014	23	10076	65		55		193	14214-90	217
	73		289	11105	17	11440	305	14215-89	217
	205	10077	289		21	11445	169	14216-89	217
	209	10080	49		49	11447	211	14217-89	165
	211		51		51	11448	179	14218-89	147
	213		113	11116	37	11451	123	14223-89	169
	215		221	11117	41	11452	249	14224-89	161
10031	65		223	11132	7	11453	169	14227-88	173
	73	10081	65		45	11454	239	14228-91	217
10033	263		157		51	11456	123	14240-90	217
10036	327		243		111	11457	127	14242-90	217
10038	73	10086	221		221	11458	63	14244-90	217
	75	10091	239	11139	127	11460	27	14250-90	165
	77	10092	35	11143	57		213	14251-90	147
	331		157		65	11464	311	14260-91	213
10039	127		175	11145	7	11472	119	14261-91	217
	233	10102	199	11147	201	11473	315	14262-91	217
	289		213	11150	41	11475	165	14263-91	51
	301		215	11155	157	11477	239	14270-92	43
	351	10103	157		299	11480	255	14273-93	127
10040	211		213	11157	7	11717	211	14278-93	217
10046	17		215	11158	123	11729	41	14279-93	217
10048	227		239	11160A	13	11733	45	14284-94	217
10049	221		289	11161	45	11739A	41	14285-94	217
10053	65		309		49	12026B	13	14286-94	217
	81	10105	205		51	1203	179	14287-94	217
10059A	123	10108	57	11165	45	12035	53	14289-94	217
	193		209	11170	111	12045	41	14293-94	217
	331		213		113	12050	45	14295-94	217
10065	27		289	11171	111		49	14296-94	217
	33	10110	35		113		51	14297-94	217
	143	10112	223	11173	69	12052	201	14298-94	217
	147	10113	351	11174	217	12053A	201	14303-91	297
	153	10114	209	11175	69	12066	201	14304-91	297
	159	10119	231	11176	297	12067A	49	14305-90	297
	161	10120	147	11177	13		51	14308-93	217
	179		263	11179	45	1309B	205	14309-93	217
	251	10122	77	11182	37		249	14310-93	217
	255	10124	57	11183	37	1311B	249	14313-93	217
	261	10130	213	11191	41		255	14331-90	189
	263	10131	213	11192	23		257	14335-90	219
	275	10132	289	11193	159		259	14338-93	219
	277	10133	159	11218	11	1319	257	14339-90	219

NUMERICAL INDEX

Part No.	Page	Part No.	Page	Part No.	Page	Part No.	Page	Part No.	Page
14339-94	189	16123-93	5	17360-83	7	221	201		255
14340-90	27	16123-94	5	17375-83	7	2216W	31		259
14341-93	219	16124-93	3	17428-57	7		323	2504	161
14348-92	219	16124-94	3	1750	319	22589-83A	11	2508	293
14349-92	219	16125-93	3	17503-92	7	22764-83	11		299
14351-92	219	16125-94	3	17510-92	7	2337W	129	2513	169
14352-92	219	16126-93	3	17521-92	7	239	21	2519	249
14353-92	219	16126-94	3	17528-92	7	23906-93A	11	2522	345
14354-92	219	16127-93	3	17529-92	7	23928-87	11	25225-93B	17
14355-92	219	16127-94	3	17530-92	7	23961-80A	11	2523	73
14356-92	219	16128-93	3	17611-83	9	23969-83	11		91
14359-92	219	16128-94	3	1783	59	23974-87	11		301
14360-92	219	16131-93	3	17921-83	9	23975-87	11	2524	311
14365-92	219	16131-94	3	17924-83	9	24002-70	15	25254-93A	17
14366-92	219	16134-94	3	17927-83	9	24032-70	15	25256-93A	17
14369-92	219	16135-93	5	17930-83	9		59	25259-93	49
14370-92	219	16136-93	5	17935-79B	9	24033-70	15	2527	345
14371-92	219	16136-94	5	17938-83	9		59	2531	187
14372-92	219	16137-94	5	17945-36B	9	24034-70	15		335
14380-93	219	16146-94	3	17947-36	9		59	25310-82A	19
14381-93	219	16165-93	3	17950-66	9	24035-70	15	25320-82	19
14382-93	219	16165-94	3	1795A	27		59	25321-82	19
14383-93	219	16166-93	3	18001-83B	5	24036-70	15	25322-82	19
14384-93	219	16166-94	3	18011-86	5		59	25323-82	19
14385-93	219	16167-93	5	18020-83	5	24037-70	15	25325-82	19
14386-93	219	16167-94	5	18074-83A	5		59	25326-82	19
14387-93	219	16207-79B	15	18076-83	5	24040-93	17	25327-82	19
14388-93	217	16216-91	3	18082-83	5	24041-93	17	25328-82	19
14390-93	217	16219-79A	3	18087-83	5	24042-93	17	2538	133
14391-93	219		15	18112-92	5	24043-93	17	25414-70A	201
14392-93	219	16241-90	3	18124-83	5	24044-93	17	25416-84	201
14395-93	217	16242-90	3	18130-83C	5	24045-93	17	25452-87A	45
14396-93	217	16247-91	3	18131-83C	5	24046-93	17	25453-87A	45
14397-93	219	16249-92	27	18133-83A	5	2420	175	2551W	115
14398-93	219	16284-84	3	18134-83	5		323		147
14402-93	217	16304-87	49	18201-83	5	24281-83	11		159
14411-94	217	1643	331	18202-83	5	2432	165		221
14412-94	217	16478-85A	3	18219-83	5	24334-36	11		225
14413-94	147	16480-92	3	18222-83	5	24335-36	11		293
14414-94	165	16510-83A	3	18229-83	5	24345-36A	11		311
14416-94	219	16512-86A	3	18268-48	331	24346-87A	11	25550-57	19
14417-94	219	16573-83	5	18523-86	9	24356-36A	11	2557	225
14418-94	219	16690-92	5	18540-83A	9	2443	129	25581-70	19
14419-94	219	16691-92	5	18542-83A	9	2444	171	25582-93	19
14422-94	189	16692-92	5	18622-85A	9	24571-93	15	2562	57
1601	17	16696-92	5	18623-85A	9	24572-93	15	2567	251
	33	16715-83	5	18633-48D	9	24581-93	17		307
	133	16770-84B	5	18634-48C	9	24586-93	17	2574WA	251
1602	131	16774-86C	5	2005	199	24599-58B	15		307
1610	331	16778-84A	7	2151	173	24600-58B	15	2576	293
16101-93	3	16779-84A	7	21920-83	11	24601-58B	15	2579	65
16103-93	3	16837-85B	5	21921-83	11	24626-87	15	2582	95
16114-93	3		15	21922-83	11	24628-87	15		269
16114-94	3	17040-92A	5	21923-83	11	24641-36	17	2592	175
16115-93	5	17041-92A	5	21924-83	11	24641-87	15	2594A	307
16115-94	5	17042-92A	7	21940-83	11	24643-87	15	2602	315
16121-93	3	1719W	41	21941-83	11	24922-93	27	26030-92	21
16121-94	3	17355-92	7	21942-83	11	24981-70	17	2604	187
16122-93	5	17356-92	7	21943-83	11	24982-70	17		193
16122-94	5	17358-84A	7	21944-83	11	2501A	75		335

NUMERICAL INDEX

Part No.	Page	Part No.	Page	Part No.	Page	Part No.	Page	Part No.	Page
26050-92	21		261	27184-92	25		323	29165-89	29
26052-92A	19		263	27186-92	25	2774	293	29166-86	27
26053-92	21	26994-90	25	27189-92	351	2782	57	29169-84	27
2607	131	26995-86A	23	27190-90A	351	2784	175	2917	179
	133	27002-89	23	27191-94	215	2787	297	29181-88	27
	135	27009-86A	23	27192-92	351	27886-78A	25	2920	323
	221	27010-86A	23	27195-92	351	2796W	233		345
26072-90A	51	27014-93A	351	27196-92	209	2804W	143	2921	171
26074-90	51	27019-89	23	27198-92	209	2806	165	29229-88A	29
26077-93	49	27026-92A	23	2720	31		177	29252-86B	29
2611B	33	27030-93	351	27206-93	23	2818	201	29256-90	27
2614	59	27035-92A	23	27207-93	23		225	29258-91	29
26207-83	21	27037-91	351	2723	191		227	29259-91A	29
26225-92	21	27038-92	23	2724	143		231	29269-83A	29
26226-92	21	27039-92	23	2726A	165		319	29274-93	115
26227-58	21		25	27280-92	25		345	29278-86	27
2623W	169	27040-88	23	27281-91	25	2823	99	29279-86	27
26262-80	21	27042-84	351	27281-92	23	2824W	193	29283-93	29
26263-80	19	27047-84	351	27291-93	215	2831	143		115
	21	27048-84	175	27296-92	213	2851	137	2929	345
26267-92	21	27078-91	351	27297-93	351	2871W	45	29292-94	27
26270-92	21	27082-91	351	27298-93	351		63	29306-92	351
26273-92	21	2708A	73	27299-93	351		123	29307-94	27
26276-92	21		115	27311-76	25		135	2933	177
26315-68A	21	27090-89	23	27315-88A	25		201	29954-71A	31
26317-68A	21	27093-92A	211	27317-88	25	2879W	3	29957-81B	31
26326-62A	21	27097-92	205	2731W	33		115	29960-91	31
26327-68	21	27100-88	23		119		133		59
26328-74	21	27101-88	23		345		149	29961-85	31
26338-68	49	27102-92	211		349		329	29970-88B	31
26345-73	21	2711	27	2733	131	28823-89	27	31340-93	37
26346-70	21		131	27339-90	25	2882W	3	31342-93	37
26348-15	21	27116-88	23	2734	301		63	31342-94	37
26348-36	21	27120-92	209	27340-90	25		123	31430-93	37
26352-85	223	27122-89	23	27360-76	25		157	31433-84A	201
26354-93	19	27123-89	23	27361-76	25		315	31504-91A	277
26378-92	223	27124-89	23	27362-76	25		319		281
26381-92	223	27125-89	23	27368-76	25	28841-89	27		285
26400-82	21	27126-89	23	27369-76	25	28842-89	27		301
26432-76A	5	27127-89	23	2737	27	2887W	323		305
2646	293	27128-89	23	27371-76	25	2888	143		307
	349	27129-88	23	2738	191	28884-92	351		309
2647B	161	27130-90	23	2739	131	28886-90	351	31506-79B	301
	177	27136-90	23		133	2889	319		305
	183	27137-81	23		135	29017-92	27		307
	301	27138-90	207	275	17	2904A	263		309
2648	161		209	27575-88	25	29059-88A	27	31510-90	37
26555-91	23		213	27576-92	25	2906	149	31514-90	37
26555-94	23		215	27577-92	25	29068-89	27	31515-90	37
26561-84	19		351	27579-88A	25	2907	299	31516-90	37
26563-91A	23	27146-89	23	27580-88	25	29070-89B	29	31516-94	37
26563-94	23	27147-89	23	27581-88	25	2908	299	31517-90	37
26566-91	23	27148-89	23	27582-88	25	2909	299	31518-90	39
26570-84	25	27156-89	23	27583-88	25	2910	299	31519-90	39
26571-89	351	27157-89	23	27585-88	25	29126-90	27	31525-90	39
2664	341	27158-89	23	27586-88	25	29134-92	27	31527-90	39
2665	209	27159-92	23	27587-88	25	29142-91	27	31530-90	39
26856-89	9	27160-89	23	276	141	29150-93	27	31535-91	39
2692WB	263	27162-89	23	2773	141	29161-86	27	31548-90	39
2698A	63	27171-89	23		197	29164-87	27	31553-90	39

NUMERICAL INDEX

Part No.	Page	Part No.	Page	Part No.	Page	Part No.	Page	Part No.	Page
40983-86	87	41835-58	331	42524-82	75	43349-84B	65	44039-86	83
40999-87	69	41836-58	331		77	43358-83A	71		85
	87	41837-58	331		81	43359-84	69	44044-88A	109
41008-87A	87	41955-93	81	42531-87	77	43403-87	71	44045-87	83
4100HW	209	41957-92	73		81	43404-87	71		85
41010-86	87	42269-30	79	42532-82	77	4350A	107	44046-84B	67
41015-86	87	42301-87	79		81	4351	95	44047-83	67
41020-86	87	42303-89A	65	42533-91	47	4352	95	44048-83	67
4104	65	42305-86A	65	42534-82	239		103		83
	95	42310-93	73	42534-90	73	43557-87	71		85
41040-88B	109	42311-58	331		75	4355A	3	44050-87	83
41042-93	191	42315-92	73		77	4356	327		85
41043-89	69	42322-93	73		331	43567-92	89	44053-83A	67
41043-89A	69	42334-82	139	42542-93	81	4357	327	44053-92	67
41109-88	69	42374-77B	331	43001-79	69	4358	37	44054-83	67
41110-79A	87	42375-87	79	43005-86	69	43608-82	71	44059-83	67
41112-79	115		81	43020-87	69		89	44061-83	67
	119	42382-87A	73	43024-73B	69	43610-87	71	44062-83	67
41113-90	127		75	43025-73B	69	43612-92	71	44063-83C	67
41114-90	87		77	43032-40B	69	43613-92	71	44072-92	67
41123-79	69		79		87	43619-84	71	44073-92	67
	87		81	43035-87	69	43626-84	69	44074-88A	67
	153	42407-87B	79	43053-86	69	4363	173	44076-86A	83
41157-87	343	42416-83	73	43057-80A	69		257	44077-88C	67
41570-77	119		79	43067-86	69	4364	173	4411	161
41571-92	127	42431-87	79	43085-81	69	43648-86	89		179
41573-84	115		141		87	43650-82	71	4412	263
41584-86	69	42437-87	75	43150-83	69		89	44126-87	73
41585-90	127	42446-87A	75	43157-83A	69		343		75
41591-90	87		77		87	43654-86A	71		77
41595-86	87	42448-87	73	4319	13		89		79
41713-86	65		75		227	43657-89	69		81
	79		77	4325	37	43662-80B	71	44136-92	71
41720-58	331		81	4326A	37	43668-82	71	44146-77	83
41731-88A	65	42452-87	75		225		89	44147-87	83
	73		77	4327	129	43671-84	71		85
	75	42455-80	73	4328	31	43672-84	71	44152-77	83
	77		75	43283-86	125	43676-88	71		85
	79		77	43288-82	343	43677-88	71	4416	13
	81		331	4329	31	4383	237	44190-88	67
41733-88	65	42457-92	73	43290-82	69	4384	309	44196-90	85
	111	42460-80B	73		87	43895-87	71	44197-77	67
41739-84A	65		75		343	4391	319	44198-87	83
41742-58A	331		77	43291-82	69	43946-86	83		85
41745-79	79		81		87		85	44199-79	83
41747-82A	65	42466-93	111		343	43957-86E	83	4420	327
	73	42468-87C	79	43292-82	69	43960-86	83	44204-90	85
	75	42473-87	79		87		85	44205-87	83
	77	42474-90A	81		343	4401W	323	44207-87	83
	79	42475-94	111	43293-82	69		341	44209-87C	83
	81	42479-90	79		87	44020-83	67		85
41755-92	73	42481-92	81		343	44021-83	67	4435W	115
41789-92	87		139	43294-82	69	44022-83	67		161
41801-58A	331	42502-90A	81		87	44023-83B	67	44447-89	71
41803-90	81	42507-89A	77		343	44029-88	71	44447-92	71
41804-84A	73		139	43299-87	87		109	4453	95
	75	42510-92	73	43312-84	69	44030-88	109		103
	77	42515-82	77	43338-83	69	44034-86	83	4460	95
	331	42522-87	77	43345-87	69	44035-86A	83	45004-85	65
41814-76A	69	42523-87	75	43346-83	71		85		79

NUMERICAL INDEX

Part No.	Page	Part No.	Page	Part No.	Page	Part No.	Page	Part No.	Page
	81	45419-80	99	45791-88	95	45931-86	103	4716W	3
45005-85	65		103	45793-88	95	45932-86	103		13
	79	45420-80	99	45827-84	91	45933-86	103		137
	81	45423-92	57	45830-48	21	45934-86	97		199
45006-87A	65		65	45832-77A	91		99		329
45013-93	65	45435-93	91		99		105	4717A	45
45016-93	65	45443-86	91		103	45935-88	107		51
45017-93	57	45446-87	91	45834-77	91	45936-88	107	4718A	7
45019-93	65	45452-87	329		99	45937-88	107		17
45021-86	57	45456-86	103		103	45940-84	93		33
45031-82A	65	45460-90	95	45838-77	99		99		49
45032-82	57	45461-87	95		103		105		51
	65	45462-87	95	45839-84	91	45949-92	95		201
45036-88	57	45463-87	97		111	45952-90	95		231
45042-82	65	45465-87	97	45841-84	91	45964-86	93	4719W	315
	79	45473-88	107	45842-77	99		105	47205-91A	121
45043-89	57	45534-87	91		103	45977-94	95	47205-94	121
	65	45544-88	153	45845-77	91	45984-87	97	47206-91A	121
45044-82	57	45546-90	95		99	45990-88	97	47206-94	121
	65	45561-87	97		103		113	4720W	327
45051-82	65	45563-87	97	45847-84	91	45991-92	127	4721	3
45057-82	73	45567-88	107	45853-83	91	45996-87	97		13
	75	45569-88B	107	45855-77	91	45998-73	99		133
	77	45583-83	111		99		105		137
	331		113	45857-83	91	46002-87	97		141
45072-87	65	45585-83	111	45858-77	93	46004-91	99		199
45085-88	189		113		99	46006-91	99		329
45085-88A	191	45587-88	113		103	46008-93	107		335
45090-92	57	45598-90A	97	45859-77	93	46020-84	93	4722	227
45092-66A	239	45605-88	103		99		99	47226-90A	127
45094-92	243	45607-93	107		103	46048-84	99	4724	179
	247	45611-86	97	45860-84	93	46053-88	107	47247-83	73
45110-88B	65		99	45863-84	93	46054-88	107		115
45111-89	65		103	45864-84	93	46055-88	107		329
45112-84A	65		107	45865-84	93	46056-88	107	4726	3
45114-77	331	45628-92	107		99	46057-88	107	4729	91
45121-88A	65	45640-88B	99		103	46059-90	153		99
45140-87	65	45648-85	99	45866-84	93	46060-88	107		103
45141-87A	65	45649-91	109		99	46065-88	107	47303-91	127
45156-89C	77	45651-91	109		103	46451-88A	113	47365-83A	141
45360-90	95	45655-88	109	45870-84	93	46452-85	111	4739A	251
45361-90	95	45659-88	109	45873-91	99		113	4740A	17
45362-90	95	45660-88A	109	45874-91	99	46459-86	111		51
45363-94	95	45662-88	109	45875-84	93	46461-86	111		57
45364-94	95	45663-88A	109		99	46462-88	113		201
45365-94	97	45668-90	97		103	46463-92	113	4741A	33
45373-88	95	45670-80	99	45905-87	97	46464-92	113		45
45374-87	95		103	45915-86	103	46995-91	119		49
45376-87	95	45672-80	99	45916-86	103	47008-92	125		51
45377-87	95	45679-92	99	45917-86	103	4701	329		65
45378-87	95	45685-93	99	45918-86	103	4702	143	47427-92A	127
45381-87	95		179	45919-87	95	47076-72	323	4742A	21
45393-87	95	45717-63	99	45920-87	95		345	47440-92	129
45401-87	95	45718-60	91	45921-87	97	47082-81	127	47449-93	319
45405-75A	91		99	45922-87	97	47132-93	237	47456-94	127
	95	45733-48	99	45923-87	97	4713W	27	4747	109
	99		103	45924-87	97		79	47491-89	115
	103	45739-87	97	45925-88	97		81		121
45417-84	99	45750-87	97	45926-90	97		319	47492-89A	115
45418-84	99	45790-80	97	45930-86	103	47159-79A	15		121

NUMERICAL INDEX

Part No.	Page	Part No.	Page	Part No.	Page	Part No.	Page	Part No.	Page
47496-90	127	48315-60	93	50078-81	117		345	52740-94	139
47499-90	127		97	50087-89A	125	5209	165	52742-94	139
47510-80	115		101	50100-70	201		293	52771-82	131
	121		105	50518-83A	141	52092-77	197		133
47511-80	115		117	50531-81	139	5210	147		135
	121		121	50588-93	141		165	52780-90A	135
47513-80	115		125	50589-93	141		169	52787-92	133
	121		331	50606-86A	141		177	52788-92	133
47515-90A	127	48330-48A	101	50613-91	141	52103-31	229	52797-87	131
47519-83A	71	48332-48B	101	50614-91	141	52106-86A	131	52798-87	131
	89	48333-80	93	50621-79A	141	52107-86	131	52799-90A	135
	343	48361-80	93	50622-83B	141		209	52800-93	135
47530-79A	93		97	50635-82	141	52108-86	131	52801-93	135
47538-79	115		101	50636-81A	139	5211	147	53156-86	153
	121		105	50639-81	139	5212	175	53165-89A	143
47541-90	127		107	50639-90	139	52128-87A	131		147
47544-85A	117	48365-48A	93	50643-82	139	52133-87A	131	53166-89	147
47551-79B	117		97	50646-82	139	52134-87A	131	53170-89	147
47552-79B	117		101	50647-82	139	52135-87A	131	53275-90	145
47556-81	117		105	50649-90	139	52138-82B	131	53278-89C	147
	121		107	50900-72	139	52139-82A	131	534	67
47564-86	117	49059-88A	111	50912-72	139	52141-82	131		109
	121	49126-77B	139	50933-86	141	52142-82A	131		127
47564-90B	127	49126-90	139	50963-92	121	52151-91A	129	53411-92A	129
47565-90	127	49127-77A	139	50972-75	73	52155-92A	129	53415-83	143
47573-89A	125	49165-90	139		79	52164-91A	129	53426-87	143
47577-86	125	49172-93	319		117	52166-93A	135	53429-93	145
47579-93	125	49176-93	319		125	52174-93	135	53434-80	143
47583-90B	127	49184-88A	117		139	52175-93	135	53435-88	143
47698-86B	125	49187-79	319		201	52183-94	135	53437-79	143
47712-91	93	49188-93	319		329	52191-86	133	53438-92	167
	125	49193-93	319		331	52192-86A	129		177
47820-81A	121	49194-85	319	50989-86	141	52201-86B	129		181
47820-90A	127	4961	123	50990-86B	141	52203-93A	133	53439-79	143
47825-81	121	49704-90	127	50991-86	105	52204-93	133		189
47826-81	121	49720-90	127	50992-87	79	52208-86A	133		193
47900-93A	117	49723-90	127	511	87	52209-90A	133		243
47904-93A	117	50003-89A	127	51184-88	133	52213-82	131		247
48031-89A	125	50005-85A	117	51185-90	133	52217-90B	133		335
48130-92	125		121	51186-89	133	52236-86B	133	53440-79	143
4813A	17		125	51188-84	135	52255-93	171	53447-87	143
48140-84	93	50009-91	121	51188-86	133	52280-94	129	53478-80	143
	97	50010-84	121	51190-92	133	52281-94	129	53482-93	311
	101	50015-74	117	51196-94	129	52283-94	133	53483-93	311
	105		125	515	73	52285-94	133	53486-85	143
	107	50018-85	125		75	52355-82	131	53487-87	117
	117	50025-84	125		77	52439-94	259		121
	121	50027-84	125		79	52440-94	259	53488-93	311
	125	50028-91	125		81	52503-88D	133	53515-86	129
4814A	45	50031-91	121	51651-79	131	5252	345	53517-86	129
4816A	153	50034-84	125	51652-83	131	52541-87	133	53521-91	129
4820A	201	50050-93	117		133	52545-84	131	53554-81	135
4822A	51	50051-93	117		135		135	53560-93	205
48300-60	93	50053-90	127	51923-86	315	52655-84	135		301
	97	50054-90	127	52020-82	131	52719-93	141		311
	101	50057-91	127	52041-82	131	52721-90	139	53563-82	143
	105	50059-85	117	5207	33	52729-90	139	53564-89	143
	107	50064-91	121		157	52735-85	133	53567-93	311
48302-85	331	50069-91	121		161	52739-83	131	53570-89	143
48306-88	107	50075-91	117		323		135	53571-94	177

NUMERICAL INDEX

Part No.	Page	Part No.	Page	Part No.	Page	Part No.	Page	Part No.	Page
	259	54585-87	149		299	58382-89	147		325
	301	54586-87	149	56397-74C	157	58383-89	147		345
	311	5465	197		299	58384-89	147	58826-89	163
53574-93	145	54701-82	149	56402-83A	157	58385-93	147	5883	63
	205	54705-81	149		299	58388-89	147	5885	183
	301	54708-65A	149	56508-76	157	58398-84	163	5887	227
	311	54710-84	149	56538-88	155	58400-80	161	58998-83	189
53575-93	145	554	127	56540-88	155	58400-94	161	59043-93	191
	161	559	327	56541-86A	155	58402-80	161	59060-92	319
	205	55915-94	157	56542-86A	155	58406-75A	171	59082-79	189
	301	55917-79	153	56567-86A	155	58408-75A	171		335
	311	55918-79	153	56569-86	153	58411-76A	171	59093-87	189
53583-92	161	55919-82	153	5702	41	58412-76A	171	59094-89	189
	323	55920-83B	153	5710	99	58415-86A	169	59112-90	199
53584-92	143	55934-92	153		103	58416-77A	171	59113-90	199
	161	55937-92	153	57215-75	79	58417-77	171	59126-86B	193
	323	56073-83	153	5724	131	58419-88	173	59129-86	189
	345		179	5736	153	58420-88	173	59136-94	199
53585-93	311		285		243	58421-88	173	59138-93	199
53593-92	323		289	5756	87	58422-88	173	59139-89	189
	345		299	5774	321	58423-88	173	59150-90	193
53598-88	147	56079-93	153	5775	211	58424-88	173	59159-80	189
53615-85	145	56081-82	153	5787	315	58425-88	173	59166-80	189
53616-85	145	56084-87A	155	57978-63	145	58426-88	173	59167-94	199
53617-85	145	56093-88	153	57994-94	171	58428-94	171	59171-93	199
	325	56105-84	155	57999-93	171	58431-94	171	59173-81A	189
5403B	129	56109-88	169	58009-89A	161	58453-89A	161	59176-93	191
	197		293	58016-89A	161	58459-80	161	59180-80	189
5414	231	56115-79B	155	58018-86	171	58460-80	161		335
54307-92	73	56116-82A	155	58031-80	161	58461-80	161	59181-80	189
54309-87	149	56117-82A	155	58036-83	171	58462-89	161		335
54312-91	149	56119-77A	155	58068-33	171	58466-80	161	59182-84	189
54316-83A	153	56122-77	155	58075-86	171	58467-94	161	59197-87	189
54317-85	149	56124-77	155	58078-49	171	58468-94	161	59211-74	189
54319-85	149	56140-84A	155	58079-49	171		281		335
54320-93	149	56141-84A	155	58080-93	171	58473-80	161	59225-93	147
54321-85	71	56148-92	155	58081-93	171	58477-80	161	59226-93	147
	89	56149-88A	155	58082-87	183	58478-86A	169	59231-86	189
	149	56151-88A	155	58084-94	171	58479-86A	169		335
54323-85	149	56153-73	155	58088-94	171	58480-88	169	59235-86	189
54324-85	149	56159-73	155	58109-88B	173	58482-86	163	59236-89	189
5444	59	56161-83A	153	58128-89	169	58484-89	163	59245-90	345
5445W	227	56163-93	155	58129-89	169	58486-89	163	59246-89	189
	231	56206-81A	157	58183-78	171	58488-84	163	59251-90	195
54473-79	149	56220-94	157	58184-86	169	58493-89	175	59254-91	133
54474-79	149	56239-93	199		349	58494-89	175		189
54475-79	149	56305-90	157	58186-86	169	58520-79A	93		195
54483-88	107	56306-90	157		349	58679-90	175	59255-72	335
54502-87	149	56327-90	157	58187-86	165	58681-90	175	59255-91	133
54506-87	149		159	58193-94	171	58683-89A	175		193
54508-89A	151	56328-90	157	58198-86	165	58684-89A	175	59258-91	117
54512-90A	149	56342-90	157	58247-86	165	58687-89	175		125
54523-82	149	56343-90	157	58311-86	169	58688-89	175	59259-90	195
54531-92	149	56351-90	159	58322-88A	169	58709-86	145		197
54533-93	149	56354-93	159	58355-86	239	58712-79A	163		345
54536-93	149	56355-92	157	58356-86	239	58713-79A	163	59261-91	189
54556-84	149	56356-92	157	58378-89	345	58714-79	163	59262-90	197
54557-90	149	56394-74	157	58379-89	349	58715-79	163	59265-90	125
54569-84	149		299	58380-89	147	58716-79	163	59267-83A	131
54577-94	149	56396-74A	157	58381-89	147	58717-79	163	5926B	63

NUMERICAL INDEX

Part No.	Page	Part No.	Page	Part No.	Page	Part No.	Page	Part No.	Page
59270-84A	131	6007	45	6057	41		209	61367-92	217
59272-90	121	601	41	60572-86	201		213	61367-94	217
	127		343	6058	33	61095-92	29	61400-94	257
59279-94	317	6012	149	60612-90	203	61103-83B	211	61411-82	249
59284-94	317	6016	7	60616-90	203	61109-85C	207	61413-86	249
59287-92	193		13	60616-94	203		209	6150W	177
	311		41	60617-93	203		211		301
59288-92	193		45	60617-94	203		213		305
	311		119	60630-90	203		215	61631-84	239
59289-92	195		201	60630-94	203	61112-82A	207	61640-84	211
	311		231	60642-85A	203		209	61641-84	211
59290-92	195		237	60647-90	39		213	61648-85	169
	311	6019	3	60647-94	39	61117-86	165	61651-90	219
59293-94	317		13	60661-93	203		249	61654-94	257
59294-94	317		67	60662-92	203	6113	149	61660-85	211
59295-94	317		209	60662-94	203		153	61661-84	211
59296-94	317		315	60664-89	203	61131-92	209	61667-90A	211
59542-87	199	60293-90	63	60664-94	203		211	6196	311
59544-87	199	60294-90	63	60665-89	203		213	6198	251
59548-87	199	60297-87A	63	60665-94	203	61134-88	219		301
59558-87	199	60298-88	63	60667-85A	203	61137-87	209		305
59569-83	193	60348-65A	49	60668-84B	201	61155-84	211	6199	307
59579-91	193	60348-81	51	60670-85	203	61157-87	211	62043-81A	211
59591-87	199	6035	301	60673-85	203	61165-89	211		251
59596-89	193		307	60678-85	203	61166-93	219	62123-66	125
59601-92	193		309	6068	171	61192-88	249	62150-85	207
59626-84	197	6036	147	6072	183		255		209
59634-81A	193		165	608	301		259		211
59634-90A	193		293	609	45	61225-94	215		213
59648-84A	193		301		49	61235-94	257		215
59655-94	193		307		51	61237-91A	211	62161-75	207
59658-79	193		309	60954-89	349	61238-91A	211		209
59710-84	265	60362-86A	63	60957-89	219	61265-92	209		211
5989	175	60363-86C	125	60960-94	259	61267-94	213		213
59893-93	199	60397-85B	63	60973-90	219	6127	149		215
59914-86A	193	60399-90A	63	60983-93	219		171	62166-81A	209
59924-80	189	604	119	6099	21	61270-88A	207		211
59926-92	193		329		57	61272-92A	209	62167-81	211
59938-72	327	6040	109		65		211		213
59954-86A	199	60403-90A	63		77		213	6217	37
59955-86A	199	60415-89B	63		81		215	62170-81A	207
59959-86	263	6042	109		191	61273-92	209		213
59964-86A	199	60427-90	63		201	61274-92	207		215
59969-86A	199	60432-93	201		225	61278-92	207	62172-75	207
59971-80	197	60432-94	201		231	61279-88	207		209
59979-93	197	6047	157		309	61311-82	249		211
59983-75	197		307	61006-92	209	61313-88	207		213
59984-73	197	6048W	27	61019-92	205	61321-80	249		215
59986-75	197	60529-90	201	61028-92	213	61322-80B	207	6220W	73
59988-72	129	6053	161	61029-92	205		249		79
	197	60533-86	63	61052-92	211	61324-88	249		187
59993-80A	197	60537-89	63	61053-92	211		255	6235	63
59994-93	197	60539-89A	201	61054-92	213	61324-99	259		175
60001-55	129	60539-94	201	61079-82	209	61335-83	209		293
	197	6054	323	6107B	63	61338-82	207		315
60004-89	197		345	6109	27	61338-84	215	62356-92	25
60005-77	197	60543-89	201		63	61338-94	207		207
60007-93	199	60543-94	201		131	61344-94	257		215
60019-93	197	60555-89	63		183	61366-92	217	6237	135
6003	53	60567-90A	201		205	61366-94	217		209

NUMERICAL INDEX

Part No.	Page	Part No.	Page	Part No.	Page	Part No.	Page	Part No.	Page
62375-57	47		171	6498	109	65647-83	225	66055-93	117
	51	63523-92	223	6506	11	65657-87	229	66104-84	163
6238	323	63525-92	223	6516HW	3	65668-87	229		233
	345	63528-92	223		87	65668-90	231	66105-77	233
6239	21	6353	107	6519	327	65669-87	229	66109-93	233
62414-91	221	63530-92	223	65190-84	229	65669-90	231	66111-93	233
62419-93	49	63533-41	15	65192-90	231	65670-82B	229	66183-82	233
62421-90	51		21	65213-92	231	65670-90A	231	66185-93	233
62423-90A	51		49	65276-62	225	65674-87	229	66188-82A	233
62429-93	49		51		227	65674-90A	231	66210-85B	233
62432-93	49	63534-90	51		231	65675-87	229	66248-93	117
62460-86	221	63535-90	51	65283-94	231	65678-85B	225	66281-93A	235
62489-93	49	63538-92	223	653	13	65680-89B	225	66309-84	233
62490-93	49	63546-87	77		17	65682-89B	225	66333-90	309
62498-91	221	63551-82	331	6530	149	65689-89	229	66347-91	237
6253W	27	63553-91	221	65302-82	227	65699-86	229	66349-84	121
	169	63554-90	21		231	65699-90	229	66350-84	121
62540-83	221		51	65324-83A	225	65701-90	231	66368-90	237
62563-65	221	63556-87	221		227	65702-86	229	6639	69
62607-93	49	63556-92	223		231	65714-91	229	6645	131
62634-84	221	63557-92	221	65325-83	225	65716-91	229		171
62637-84	221	63559-91	221		227		231		183
62640-93	49	63561-87	75		231	65721-85	225		211
62649-90	51	63562-92	223	65327-93	231	65722-85B	225	6653A	335
6265	179	63563-85A	221	65328-83	225	65723-85	225		343
62672-90	51	63572-86	221		227	65724-85	225	6655	95
62673-90	51	63573-82	333		231	65732-86	229		103
62681-92	51	63591-93	207	65374-90C	231	65738-89B	229	66600-84	117
62683-93	49	63609-72	331	65380-85	227	65739-89B	229	66997-86A	239
62684-93	49	6365	211	65380-90	227	65746-90A	231	66998-86	239
62704-93	221	6366	73	65381-89A	227	65747-87	229	66999-86	239
62707-84	221		75	65382-89C	229	65747-90A	231	67000-85E	239
62725-90	221		77	65395-89B	229	65781-82	229	67000-94	239
631	51		79	65401-86	227	65782-82	229	67002-93	311
6314W	41		81	65410-83	227	65802-90	229	67003-86D	239
6316HW	41	6371	109	65411-80A	227	65813-91	229	67003-94	239
6333	133	63796-77A	223	65432-89	227	65814-91	229	67009-72	117
6334	79	6379W	133	65447-86	227	65821-90	229	6700B	331
6335	323		179	65459-84A	227	65824-90	231	6701	3
	335		197	65464-89	227	65826-90A	231		63
	345		199	65475-89	227	65827-90	231		95
634	45		315	65483-89	227	65828-90	231		115
63497-89	221		317	65487-89	227	65862-91	225		123
63501-68	25	63813-90	223	65492-91	227	65863-91	225		127
	207	63858-49	9	65502-89	225	65866-91	229		133
	209	6398	63	65519-52B	225	65867-91	229		137
	211	6400HB	59	65522-91	227	65868-91	231		161
	213		141	65538-85	225	6590HW	69		179
	215	6409	191	65539-86	225	65989-90A	233		199
63504-84	207	6410	129	65571-82	227	65991-82A	233		227
63505-84	25		131	65603-86	227	65995-88A	233		231
	209		133	65611-92	225	66000-80	233		263
	211		135	65621-83	225	66004-93	233		315
	213		323	65626-85A	225	66010-82A	233		323
	215	6411	169	65627-85	225	66029-80	117		327
	271	6416	323	65630-83A	225	66030-88	107		329
63511-93	49		341	65632-83B	225	66042-79A	221		335
63513-88R	221	64511-63	305	65634-92	225		233	67014-91	247
63515-92	221	6474	123	65636-85	225	66043-93	233	67017-94	259
6352	79	6497HW	41	65645-89	225	66046-93	117	67018-91	247

NUMERICAL INDEX

Part No.	Page	Part No.	Page	Part No.	Page	Part No.	Page	Part No.	Page
6702	3		345	67121-92	243	67236-80	241	67754-92	163
	63		349	67122-85	247	67237-80	241	67755-81A	165
	79	67030-91A	253	67123-86A	239	67238-80	241		177
	91	67033-94	259	67125-86A	251	67239-83	351	67757-92	179
	99	67034-83	243	67126-91	247	6724	151	67762-87	179
	103	67037-91	243	67127-84A	243	67243-84	241	67763-93	181
	115	67041-91	245		247	67245-93	241	67768-86	179
	123	67042-85	243	6712B	331	67246-93	241	67769-82	179
	135	67046-92	243	67132-85A	247	67266-94	195	67769-93	179
	157	67055-92	243	67136-85	249	67271-94	259	67772-80	179
	161		247		255	67276-94	259	67773-80A	101
	183	67060-87A	239		259	6736	7		179
	187	67063-89	243	6716	33		41	67775-81B	163
	193	67067-76	233		77	6737	7	67775-94	163
	205		251		143	6738	141	67777-80A	181
	209	67068-76	251		159		149	67778-60	167
	215	67069-76	251		187	6753	153		177
	225	67070-76	195		197	6756	107	67780-60	167
	227		251		249	6758	67		177
	231		263		331	67608-86	241	67781-92	181
	239	67072-87B	239	67166-88	251	67615-89	183	67782-60A	167
	243	67073-87A	239	67168-88A	243	67621-94	171		177
	315	67075-57A	35	67169-88A	245	67622-94	149	67789-91	181
	319	67078-85A	247	6717	143	6762B	7	67790-82	181
	329	67079-86A	251		165	67668-89	183	67790-93	181
67020-85A	247	67080-87	247		177	67674-94	177	67793-92	167
67021-85B	247	67085-83	243		345	67685-92	179		177
67023-84F	239		247	67171-88	243	67692-92	163		181
67023-94	239	67086-85	247	67172-88A	243	67695-92	167	67798-92	167
67024-84A	251		249	67175-89	255	67696-81	165		177
	255	67094-85	243	67176-89	255		177		181
67025-91	247		247	67178-93	255	67697-81	165	67800-93	167
67027-91A	251	67095-85	247	67179-93	255		177	67800-93A	241
67028-86A	241	67098-87	71	6718	137		179	67801-92	167
67028-94	241		239		149	67698-81C	179		177
6703	57		243		327	67702-81A	165		181
	59		247	67184-94	259		177	67805-92	181
	63		251	67185-88	249	67704-93	165	67807-92	181
	65	67103-91	243	67186-88	243	67705-92	179	67808-86	105
	91		247	67187-88	245	67712-83	165	67815-59A	181
	115	67104-83	247	67190-89	255		177	67816-86	105
	119	67105-91A	243		259	67713-86	179	67817-83	167
	123	67106-83	243	67191-94	259	67716-60A	165	67819-86	105
	131		247	67196-94	259		177	67820-86	105
	143	67107-83	243	67197-94	259	67718-60A	165	67821-87	105
	159	67108-83	243	67200-86A	247		177	67822-88	261
	165		247	67202-91	247	67719-63	179	67823-92	181
	187	67110-92	243	67205-89	255	6771A	223	67826-92	247
	193	67112-83	243	67211-86A	241	67724-71	165	67827-88	261
	197	67115-91	251	67212-93	251		177	67828-88	261
	205	67117-85	239		255	67725-63	179	67829-88	261
	215		243	67215-89	251	67726-71	165	67834-83	181
	221		247	67215-93	255		177	67839-74	181
	225		251	67216-86B	241	67730-91	179	67841-93	181
	233	67117-93	255	67219-86	241	67732-71	177	67846-70	159
	235	67118-87	251	67229-85	241	67732-71A	165		167
	239		255	6723	327	67743-84	179		183
	301	67119-85	249	67232-85A	241	67744-75	179		297
	305	67120-84B	251	67233-80D	241	67746-85	163	67849-93	181
	319		255	67234-84	241	67748-87	179	67858-39	185

NUMERICAL INDEX

Part No.	Page	Part No.	Page	Part No.	Page	Part No.	Page	Part No.	Page
67858-89	159	68399-88A	163		185	69631-94	269	70199-92	305
	167	68400-86	183	68633-89	185	6970	143	70216 -93A	269
	183	68401-90	185	68634-86	167	70005-70	289	70218-87A	299
	303	68402-86	263		277	70011-84B	269	70219-87	299
67859-90	127		341	68654-92	167	70022-83	269	70221-94	341
67862-94	177	68403-86A	265		177	70027-83	269	70232-94	277
67865-89	121	68406-86C	261		181	70028-85A	335	70234-93	269
	141	68407-86	263	68661-87	183	70028-94	335	70237-94	339
	181	68408-86D	261	68668-87	183	70029-90	269	70245-93	269
67866-94	177	68410-87B	263	68671-69A	185	7003	81	70245-94	285
67868-94	177	68424-89	265	68672-38	185	70032-90B	269	70250-93	269
67872-89A	181	68430-89	265	68674-69	185	70034-82	269	70267-93A	269
67879-94	259	68440-86	163	68684-86	185	70036-93	269		273
6788	315		183	68688-89	159	70043-81	289	70281-89	271
67880-94	259		265	68690-69	185	70045-94	273	70282-94	281
67892-93	179		341	68705-93	181	70047-82	299	70284-93	269
67894-93	181	68452-86	163		269	70048-92	181	70285-89	269
68008-73B	263		183	68706-94	189	70050-92	269	70287-81	241
	339		261	68708-93	255	70060-92	269		289
68010-90	265		265	68713-94	263	7007	79		337
68020-92	245		341	68714-94	189	70078-91	269	70288-81	277
	247	68456-89	197	68720-62	185	7008	165		281
68021-92	245	68457-86	261	68721-62	185	70082-82	299		289
	247		265	68725-62	185	70083-89	269		337
68023-92	245	68460-82	241	68740-91	245	7009	81	70289-89	283
	247	68460-92	241	68745-93	265	70102-90	269		289
68024-92	243	68462-64	251	68750-93	117	70103-90	269	70291-89	275
	247	68464-86	245		289	70107-90	269		285
68024-94	259	68468-86	245	68765-94	265	7012	75		289
68026-73	263	68480-73	265	68766-94	163		109	70292-89	29
	339	68480-93	265		183	70132-89	269		289
68027-90	263	68493-90	265	68767-94	185	70141-93	159	70293-87	289
	339	68493-92	265	68785-94	195		269	70294-87	289
68032-90	265	68505-90	163	68799-94	259	70141-94	159	70296-89	269
68033-90	263		185	68808-94	285	70142-93	155		295
	339	68506-92	265	69012-93	267		269	70297-93	269
68036-91	265	68507-90	265	69032-93	267	70142-94	273	70301-93	271
68046-79	195	68510-74B	265	69060-90A	267	7015	307	70302-90	289
68047-79	195	68513-92	245	69062-91	267	70158-89	169	70305-90	289
68048-93A	263	68516-92	181	69114-90	267		269	70321-89	271
68049-93A	265		245	69120-91	267	70160-91	293	70328-84	271
68050-93	181	68519-68	163	69125-65	267	70160-94	293	70339-91A	35
68051-93	181		185	69126-92	29	70168-89	295	70341-89	295
68052-93	181	68536-75	159	69505-89	189	7017	165	70344-92	271
6812	107	68537-89D	301	69540-78	249		169	70345-84	35
	109		305	69551-91A	269		257		283
68123-73	263		307	69551-94	269	70172-89	269		291
	339		309	69555-92	269	70172-94	275	70347-84	291
68163-84	163	68555-87	261	69555-94	269	7018	165		309
	261	68566-90	261	69556-89	271	70184-93	349	70349-92	169
	265	68570-94	301	69558-92	269	70184-94	349	7036	33
68168-89	147	68570-94A	301	69558-94	269	70185-93	255		147
	163	68572-64B	265	6960	327	70186-82	47		187
	183		341	6961	327		121		293
	261	68594-84	189	69617-82	249		269		323
	263	68597-86	245	69618-82A	249	70187-82	35		329
	339	68601-94	177	69619-82	249	70191-73A	155		345
68169-90	265	68608-83	245	6962	327		269	70377-93B	269
68392-91A	265		247	6963	327	70196-86	189		273
68398-88	163	68619-83	167	69631-93	269	70197-86	155	7038	13

NUMERICAL INDEX

Part No.	Page	Part No.	Page	Part No.	Page	Part No.	Page	Part No.	Page
	79	70553-69	271	70995-93	207	71299-93	255	71552-75	305
	95	70554-69	271		215	71300-79	253	71552-94	305
	127	70555-69	271	70999-94	215	71300-94	253	71554-75	305
	137	70556-71	271	7100	45	71302-93	255	71555-90	309
	141	70558-71	271		119	71307-94	259	71557-93	299
	149	70559-71	271		263	71309-92	197	71560-84	307
	179	70578-89	291	71001-94	259	7130W	161	71563-82A	299
	227	70579-65	251	7101	115		263	71564-82A	299
	329		285		161		335	71567-82	299
70384-94	285		291		263	71310-94	177	71568-82A	299
7039	3	70580-89	291	71014-88A	243	71419-93	127	71580-84	307
	91	70581-73	341	7102	301		255	71583-85	307
	99	70581-93	335		351	7142	123	71585-93	159
	103	70583-93	291	71090-64	251	71421-90	127	71585-94	159
	119	70585-93	291	71092-68A	251		309	71589-92	299
	137	70586-93	291	71099-74	241	71421-94	127	71590-92	299
	141	70587-93	291		249	71424-83	305	71591-92	299
	323	70642-91	297		255	71425-77	305	71592-88	299
	327	70642-94	297	71134-68	253	71426-93A	301	71593-88	299
	329	70643-79B	145	71141-68	253	71427-93	301	71594-88	299
7041	33	70644-79A	145	71142-93	255	71427-94	309	71595-86	299
	37	70646-90	145	71143-90	253	71428-90B	309	71597-92	299
	41	70646-94	145	71144-75A	253	71441-94	305	71598-92	299
	63	70648-89	145	71145-75	253	71451-78	305	71600-93	307
	65	70648-94	147	71146-94	259	71451-94	305	71795-63A	195
	91	70649-91	147	7115	123	71452-91A	127		337
	99	70650-91	297		143		145	71805-88	299
	103	70654-86	299	71150-92	253		163	71806-88	299
	113		349	71151-92	253		177	71807-88	299
	115	7068	69	71152-92	253		205	71809-88	147
	119		133	71158-86B	253		255		295
	123		137	7118	33		259		297
	137		141		119		301	71814-91	147
	141		149		193		309	720	13
	157		153		293		311	72023-51A	73
	179		179		335		325		75
	183		327	71182-47A	253		345		77
	187		329	7124	31	7145W	313		79
	193	7069	33		91	71501-73A	307		81
	211		91		103	71501-93	255		301
	225		183		123		259		307
	227		205		143	71501-94	307	72028-83	291
	251		249	71241-91	253	71505-89	169	72029-84	291
	263		341	71246-92	255		301		337
	315	7073	171	7127	57	71506-84	307	72034-71	265
	319	70933-90	351		187	71506-94	307		283
	323	70936-91A	251		225	71512-89	303		291
	345	70939-84A	251		261	71513-89	159	72035-71	291
7042	261	70941-84A	251		321	71518-80	305	72036-71	291
	263	70958-93	159	7128	143	71521-89	297	72037-71	291
7043	323	70963-92	29		161	71522-94	177		337
	327		269		323	71526-93A	301	72038-71	29
	329	70966-84	271		345	71535-94	301		111
	343	70970-91	305	7129	95	71536-93	301		113
7045	137	70979-86	305		269	71540-94	177		241
	179	70982-93	255		293	71541-84	307		245
	263	70984-90A	309	71294-89	207	71543-93	301		247
70504-81	157	70985-93	271	71295-68	253	71544-93	301		249
70551-69	271	70985-94	283	71296-93	241	71545-93	301		255
70552-69	271	70987-90A	309	71297-68	253	71550-75	305		283

NUMERICAL INDEX

Part No.	Page	Part No.	Page	Part No.	Page	Part No.	Page	Part No.	Page
	285		275	72138-94	301		275		349
	291		277	72138-94GY	273		283	72198-94	273
	299		281	72139-94GY	283		299		277
	337		283	72142-94	111		349		283
	339		285		273	72172-94	291		287
72039-71	163		341		297	72173-94	291		293
	167	72104-94BK	275	72143-94	35	72174-94	291	72199-93	297
	185		283		159	72176-94	291	72199-94	49
	241		285		275	72178-94	291		111
	247		341		277	72179-94	259		159
	249	72106-94BK	277		281		291		273
	255		281		283	72190-94	35		277
	261		283		285		111		281
	265		285		341		159		283
	275		293	72144-94	275		273		287
	277	72108-94BK	273		283		275		293
	281		275		285		277	7220	33
	285		277		341		281		65
	291		281	72146-94	277		283		95
	299		283		281		287		175
	337		285		283		291		179
	349		293		285		293		187
72040-71	291		335		293		297		269
72041-71	277	72109-94BK	275	72148-94	273		335	72200-94	275
	281		277		275		341		277
	291		281		277	72191-94	25	72203-94	275
	337		285		281		29		277
72043-71	241	72112-94BK	25		283		35	72205-94	277
	247		277		285		145		281
	249		281		293		147		287
	285		293		335		159	72206-94	287
	291		297	72149-94	275		163		303
	299	72113-94BK	29		277		185	72207-94	287
72044-71	241		159		281		259		303
	285		163		285		273	72208-94	277
	291		189	72152-94	25		275		281
	337		259		277		277		287
	339		283		281		281	72209-94	279
72045-90	291		285		293		283	72215-94	279
72046-79	277		339	72153-94	29		287		287
	281	72114-94BK	163		159		291	72216-94	279
	285		335		163		293		281
	291	72116-94BK	159		189		299	72217-94	279
72048-90	291		293		259		301		281
72051-77	35		299		283		335		287
	291	72118-94BK	35		285		339	72218-94	279
72052-79	145		195		339	72195-94	35		281
72054-84	337		275	72154-94	163		163		287
72055-94	147		291		335		259	72219-94	279
	349		335	72156-94	159		273		281
72056-92	291	72119-94BK	259		293		275		287
72057-84	337		275		299		277	72220-94	279
72059-89A	147		283	72158-94	35		281	72221-94	283
	297		299		195		283	72222-94	279
72060-94	147	72128-94GY	277		273		287		281
721	49		281		275		291	72223-94	283
72102-94BK	111		283		291		293	72224-94	283
	273		285		301		299	72225-94	279
72103-94BK	35	72129-94GY	277		335		301		281
	159		281	72159-94	259		339	72226-94	279

NUMERICAL INDEX

Part No.	Page	Part No.	Page	Part No.	Page	Part No.	Page	Part No.	Page
	281		251	74529-79A	31		227	7609W	293
72227-94	279		293	74536-77A	35		231	7613A	177
	281		301		145		267		187
	283		305		291		315	76175-86	147
72229-94	279		309		337	75079-94	257		169
	281	722A	45		339	75101-82	221	76176-86	169
	283	7230	41	74539-77A	35		233	76192-92	349
72233-94	275		123		145	7515	41	76192-94	349
72234-94	281		141		291	7520	143	7620W	305
72235-94	275		175		337	7531	3	76238-86	169
72236-94	281		263		339		63	7624	187
72238-94	275		269		341		65		197
	281		305	74587-94	279		119		335
72239-94	275	72300-89	279		281		175	76240-88	295
72241-94	273		281		287		187	76248-86	295
	283		303	74589-73	303		191	76249-86A	295
72242-94	283	72301-89	303		305		193	76250-86B	295
	287	72302-89	303		307		205	76252-86	295
72243-94	283	72306-88	303		309		215	76253-86	295
72249-94	159	72316-93	303	74590-93	303		221	76255-86	295
	273	7232	107	74598-73	303		225	76258-86	295
	275		131		305		227	76259-86	295
	279		209		309		231	76260-89	295
	283		251	74599-77B	303		319	7626W	33
	287	72321-93	303		305	7548W	123	7627	107
	293	72322-93	303		307	7549	251		109
	341	72332-94	303		309		255	76274-88	295
72253-94	275	72334-94	303	74600-94	287	7549A	259	76277-88	295
72255-94	283	7234	129		303	755	187	7628	199
72257-94	275	72340-94	279	7490	319	7554	149		263
	279		281	7492	293	7576	267	76280-88	295
72258-94	275	72342-90	309	7501	263	7586	143	76281-88	295
72266-94	159	72343-94	303		339		161	76282-88	295
	273	72501-74	181	75032-87	169		311	76283-89	295
	275	72502-74	181	75034-82	249		323	76284-89A	129
	279	72503-90	291	75039-86	249		345	7629	17
	283	728	119	75040-88	207	7588	109		33
	287		123	75044-84	169	7590	249		187
	293	729	239	75045-84	169	7593	13		193
72268-94	159	735	119	75047-88	249		225		239
	275	739A	45		255		227		301
	279		201		259		231		305
	281	740	119	75049-88A	249	7594	129		307
	283		127		255	7596	115		309
	287	7415A	175		259	7598	327		335
72275-74	291	74406-87	19	75058-88	249		329		351
	337	74407-86	283		255	7600	187	76292-92A	271
72276-74	163		291	7506	13	7601	3	76294-93	295
	291	74408-89	177	75062-90	249		27	76297-89	297
72277-74	291		297		255		115	76299-89	349
72278-74	291	74412-91	291		259		127	76299-94	349
72283-94	279	74414-93	295	75067-94	257		315	76303-89	147
	281	74420-94	49	75068-94	257		317	76304-91	147
	283	74519-88	31	7507	41		335	76305-93	295
72284-94	275	74521-77	35		63	7602	307	76307-89	147
	281		145		123	7606	179	76315-91	147
72290-94	287		291		171	7608	143	7634	33
7229W	81		337		187		249	7638	205
	115	74526-86	169		209		311		249
	233	74527-86	169		213		349		335

NUMERICAL INDEX

Part No.	Page	Part No.	Page	Part No.	Page	Part No.	Page	Part No.	Page
7643W	133		169		329		351	87002-83	331
	199		175	7780	13	8101	225	87006-85	325
	313		235		323	8102	115	87007-85	329
7651	171		293		341		193	87008-88	329
7653	165		309	7782	13		255	87010-85	329
7667	109	77161-94	147		123	8107	161	87011-85	329
	137	7725	161		137	8108	79	87013-85	329
	319		329		227		103	87014-85	325
7669	63	7727	329	7783	13		115	87015-85	329
7680	169	7729	331		95		123	87018-85	329
7680W	107	7734W	127		123		211	87019-85	329
	133	7736	41		315		249	87020-85	329
	199		123		329		267	87022-88	329
7682	165		321	7792	129	8126	187	87023-88	329
	187		323		197		317	87024-85	329
7683	187	7739	69	7796	269	8131W	335	87025-85A	329
	193		153		309	8135B	193	87027-85	337
7686	33		161	7800W	179	813A	119	87029-85	331
	57		345		263	8155	251	87030-85	325
	65	7740	79	7812W	149	8204	231	87032-85	331
	115	7742	77	7823	335	83162-51	19	87038-85	333
	119		81		343		35	87039-85	333
	131		123	7824	115	8476	211	87040-85	333
	143		225		119	8483	33	87041-85	333
	161	7743	205		149		157	87042-85	333
	165		249	7825	79		193	87043-85	333
	169		319	7827W	87		197	87048-88	329
	171	7744	41		323		307	87056-83B	325
	221		73	7830	297	84850-92	145		327
	267		75	7837W	323		163	87071-89	333
	293		77	7838	37		207	87073-79	333
	301		81	7843	327		325	87113-83	333
	319		261	7845	69		345	87114-93	327
	323	7748W	79		149	8500A	143	87117-36	325
7688	31		91		329	8505	187	87120-79	325
	323		99	7848W	55	8508	191		341
	329		103		137	8535	27	87121-79	341
	345		117	7855W	73	853A	153	87122-83	327
	349		141		75		243	87123-83	327
7689W	187		227		77	8540	317	87131-83B	327
	233		323		81	854A	179	87132-92	327
77004-80	169	7753	33	7860	323	855B	3	87137-92	327
	295		123	7862	225		67	87141-83	327
77026-92	275	7763W	251		81		107	87142-83	327
77029-86A	295	7768W	153		231	856A	41	87143-83	327
	349	7772	115	7868	315		117	87144-83	327
77032-89	349		119	7869	197		137	87148-92	327
77036-86	169	7775	115	7878	147	858	201	87156-83	327
77060-86	169		161	7880	137	861A	137	87157-87	325
77070-88A	169		199		179		141	87159-83	325
77092-89	297		323	7883	13		179	87160-83	325
77100-89A	297		327	79041-90	145	8625	27		327
77101-90A	159	7776W	319	7916A	17	864	27	87166-93	327
77113-89	159	7778	3	7987	87	8672	231	872A	137
77147-91	295		59	7993	331	868	133	87435-83	325
77148-91	295		87	7994	69	8692	161		343
7716	119		123	8096	313		193	87444-33	325
	129		137	8099	119	8699	17		343
	141		183		221		33	87672-76	333
	159		315		315	8700	323	87701-79	325

NUMERICAL INDEX

Part No.	Page	Part No.	Page	Part No.	Page	Part No.	Page	Part No.	Page
87705-79	343	88696-67	325		347	91107-77	189	928	37
87706-83	333	88698-67	325	90688-85	145	91123-77	195	929	37
	343	8871	37	907	249	9114	41	932	115
87710-83	343	8873	21	90700-93	311	9115	41		129
87711-83	343		45	90702-89	313	9120	13		173
87712-83	343	8876A	53	90703-89	313	9121	13		259
87713-83	333	8879	37	90706-89	313	9122	13	933	33
87714-83	333	8883	37	90708-89	313	9123	13		157
87752-89	333	88862-91	325	90712-89	313	9124	13		161
87776-92	333	88865-89	347	90714-89	313	9125	13		323
87778-64A	333	891	21	90718-79A	319	9126	13		345
87901-83A	337	89579-91	267	90720-79A	319	9127	13	939	31
88100-24A	325	8977	45	90731-89	313	9128	13		123
88100-94	325		49	90743-88	145	9129	13		205
88172-25	325		51	90752-93	311	9130	13		215
88174-37	325	8996	45	90753-93	311	9131	13	940	201
88174-94	325		49	90756-93	311	9132	13	941	201
88175-94	325		51	90757-93	311	9133	13	94435-82C	311
882	7	8998	45	9076	123	9134	13	95578-41	71
88261-36	325	90180-93	319	90763-79	295	9135	201		89
88264-36	325	9028	13	90764-93	311	9139	109	95581-47	71
88301-79	325	90346-90	315	9077	37	9140	109		89
	341	90346-94	315	90770-79	57	9141	109	95582-47	71
88302-79	325	90350-89	313	90771-79	291	91583-91A	129		89
	341	90351-89	313	90781-93	319	91721-82	169	95594-84	71
88314-37	325	90357-89	313	90785-90	315	91768-85B	133		89
	341	90358-89	27	90785-94	315	91791-87	315		343
88403-93	349	90359-89	313	90787-90	315	91792-87	315	95595-84	71
88403-94	349	90360-89	313	90787-94	315	91808-89	163		89
88404-93	349	90361-90	315	90801-93	319		169		343
88425-67	325	90361-94	315	90804-92	315		349	96210-80	15
88426-91	325	90469-94	117	90804-94	315	91812-89	163	97000-93	135
88427-91	325	90470-90	315	90806-92	315		169	97001-93	145
88428-91	325	90471-90	315	90806-94	315		349	9842	273
88481-91	325	90473-94	315	90817-94	317	91841-93	311	9843	273
88487-91	325	90474-90	309	90818-94	317	91849-85B	173	9847	289
88489-89D	347	90476-93	315	90820-93	311	91850-87	133	9848	289
88490-88A	347	90477-93	315	90821-74A	145	91875-88	321	9852	289
88492-89	347	90480-85	329	90823-94	317	91892-88	321	9856	143
88494-89	347	90481-91	329	90844-80	145	919	131		249
88495-89	347	90483-85	309		147		135		255
88496-89A	347	90493-83	121		209	91902-88	321		259
88497-89A	347		141	909	305	91904-88	321		289
88500-89	347		147	90934-93	319	92061-83	245	9857	33
88501-89	347	9052	69	90935-93	319		247		113
88503-91A	325		87	90936-93	319	92070-86	247		165
88504-91A	325		343	90943-93	319	92079-88	245		179
88526-91	347	9058	17	90945-93	319	92080-88	245		243
88527-91	347	90594-85	319	90946-93	319	922	169		247
88528-91	325	90601-93	311	90958-93	311		175		249
88530-89A	347	90603-93	311	90962-93	311		293		255
88531-91	347	90635-94	317	90964-63	145	923	65		285
88536-91	347	90649-85	145	90965-63	145		103		289
88537-91	347	90663-85	145	90967-64	145		247		341
88538-91	347	90664-93	311	90972-93	311		249	9858	289
88539-91	347	90665-93	311	91013-79	195	924	169	9859	289
88545-93	347	90670-93	311	91023-79	195		211	9860	289
88546-93	347	90675-93	311	91085-83B	189		293		341
8860	141	90682-93	311	91090-77A	189	925	37	9862	31
88695-67	325	90686-92	145	9110	13	927A	21		289

NUMERICAL INDEX

Part No.	Page	Part No.	Page	Part No.	Page	Part No.	Page	Part No.	Page
9863	33		309						
	289	9955	225						
9864	289		227						
9865	289		231						
9866	283	9969	221						
	285	9988	157						
	289		209						
9868	289		351						
9871	143	9990W	57						
	147								
	289								
9875	289								
	299								
9881	33								
9890	211								
9892	289								
9894	27								
	249								
9898	277								
	281								
	285								
	289								
	299								
9900	33								
	183								
	289								
99000-77	133								
	135								
99013-82	131								
9904	159								
	289								
	297								
9905	283								
	285								
	289								
9907	33								
	183								
	285								
	289								
	349								
9908	33								
9914	111								
9930	159								
	289								
9937	159								
	275								
	277								
	281								
	283								
	285								
	289								
	293								
9938	289								
9945	289								
9946	111								
9951	33								
9952	179								
	301								
	305								
	307								