

Dyna 2000i Programmable Digital Ignition System For Harley-Davidson Motorcycles

● DESCRIPTION

The DYNA 2000i Digital Ignition is designed to replace the factory ignition module and sensor used on 1983 and later Harley-Davidson EVO motors. It is also an ideal upgrade for early electronic and breaker-point systems that require a mechanical advancer. The entire ignition fits inside the engine in place of the cam sensor or point plate and connects directly to the coils without the use of an external module.

The 2000i will operate in single- or dual-fire mode and features 8 advance curves and 4 rpm limits to fit a broad range of engine builds and riding styles. For nitrous and turbo equipped bikes, a single stage retard is provided.

A tach output is included, eliminating the need for an additional adapter when operating in single fire mode. Two diagnostic indicators assist in trouble shooting and static timing.

● INSTALLATION NOTES

****IMPORTANT**** Coil primary resistance must be in the range of 2.5 to 3.5 ohms.

****IMPORTANT**** Carbon, graphite or spiral core type suppression spark plug wires are required to reduce interference. Do not use metal core wires.

****IMPORTANT **** The 2000i requires the gold colored timing rotor used on 1983 and later EVO motors (HD part no. 32402-83). The earlier silver colored cup will not work properly. Bikes originally equipped with points (except distributors) or early electronic ignition will accept the later model cup without modification.

● DUAL FIRE INSTALLATION

Single plug: use Dynatek DC6-1 or stock coil. Dual plug: use two DC2-1 coils wired in series (equals 3 ohms).

1. Remove the stock ignition module. Remove the outer and inner covers on the cam position sensor. Mark the engine case near the middle of the sensor. Remove the cam position sensor. The pins may be removed from the connector housing by slowly but firmly pulling the wires from the rear of the connector.

2. Feed the wires of the 2000i through the hole in the engine case and seat the ignition. Rotate until the timing pickup (nearest to the switches) is at the mark made in step 1. Replace the screws that held the cam position sensor, finger tight.

3. Remove the wires from the coil. Use a test light or meter to find the white wire that has +12V when **both** the key and the Run/Stop switches are on (later models have only a single white/black wire). Attach this **and** the white wire from the 2000i to one of the primary terminals. Attach the pink wire from the 2000i to the other primary terminal.

4. Tach connection (if equipped). Attach the pink wire from the tach to the 2000i green wire with the large (.250) blade connectors. If the bike had only one pink (or pink/black) wire at the coil, connect this to the 2000i green wire.

Do not connect the 2000i tach wire to the coil or damage to the ignition may result.

5. Remove the wire from the VOES (Vacuum Operated Electric Switch). Connect the 2000i purple wire with the small (.187) receptacle terminal. If the VOES is not installed, see the tuning tips on the last page.

The blue wire is left unconnected. If there is no tach, the green wire is left unconnected. These should be folded back and tucked into the harness sleeve. The unused stock wire harness can be removed or taped up.

6. Skip to the "Configuring The Mode Switches" section of these instructions.

● SINGLE FIRE INSTALLATION (Two coils, one firing each cylinder)

Single plug: use Dynatek DC6-5 Twin-Fire II Performance Coil or two DC3-1 single output coils. Dual plug: use two DC1-1 coils or DC6-4 Twin-Fire. Mounting brackets for two-coil installations are available from your dealer.

1. Follow the "Dual Fire Installation Instructions" above, through step 2.
2. Remove the coil. Use a test light or meter to find the white wire that has +12V when **both** the key and the Run/Stop switches are on (some models have only a single white/black wire). Attach this **and** the white wire from the 2000i to the coil (+) terminal (a jumper is supplied for two-coil installations). Note: dual tower coils do not have a (+) terminal; either one can be used.
3. Connect the 2000i pink wire to the rear cylinder coil (-) terminal. The blue wire connects to the front cylinder coil (-) terminal.
4. Tach connection - attach the pink wire from the tach to the 2000i green wire with the large (.250) blade connectors. If there is no tach, fold the wire back into the harness sleeve.

If the bike had only one pink (or pink/black) wire at the coil, connect this to the 2000i green wire.

Do not connect the 2000i tach wire to the coil or damage to the ignition may result.

5. Remove the wire from the VOES (Vacuum Operated Electric Switch). Connect the 2000i purple wire with the small (.187) receptacle terminal. If the VOES is not installed, see the tuning tips on the last page.

If there is no tach, the green wire can be folded back and tucked into the harness sleeve. The unused stock wire harness can be removed or taped up.

● CONFIGURING THE MODE SWITCHES

The 2000i has 6 mode switches which allow you to configure the ignition for your engine build and riding style. Stick the enclosed switch position label on the inside of the cam cover for future reference.

| <u>Switch 1</u> | <u>V.O.E.S.</u> | <u>Description</u> |
|-----------------|-----------------|--|
| OFF | Normal | Allows timing to reach full advance by 1500 rpm under light engine load conditions, improving throttle response and gas milage. Most bikes should be set to this mode. |
| ON | Retard | Uses the V.O.E.S. wire to retard timing for nitrous or turbo equipped bikes. See below for further explanation. |

| <u>Switch 2</u> | <u>Switch 3</u> | <u>Advance Curve</u> | <u>Description</u> |
|-----------------|-----------------|----------------------|---|
| OFF | OFF | Curve 1 - | This curves brings up the advance the earliest and to the highest final value (most aggressive). |
| ON | OFF | Curve 2 - | This curve brings up the advance a little slower than curve 1 to prevent detonation on near stock motors. |
| OFF | ON | Curve 3 - | This curve is good for built motors that tend to detonate, advance comes in slower than curve 2 and to a lower final value. |
| ON | ON | Curve 4 - | This curve should only be used if your motor still detonates using curve 3, advance is brought in still slower and to a lesser final value than curve 3 (least aggressive). |

The proper advance curve will be determined by the level of engine modification, weight of bike and rider, gasoline octane rating, air temperature, altitude, etc. Start with curve 2 which is similar to the stock curve. If you experience any "pinging", try curve 3 . If the bike runs well on curve 2, try curve 1. Generally, you should run the curve that is most aggressive without causing pinging.

| <u>Switch 4</u> | <u>Switch 5</u> | <u>Rev Limit</u> | <u>Application</u> |
|-----------------|-----------------|------------------|---|
| OFF | OFF | 6000 RPM | stock motor |
| ON | OFF | 6500 RPM | modified street motor |
| OFF | ON | 7000 RPM | race motor (most Harley valve trains don't like |
| ON | ON | 7500 RPM | race motor to be revved this high) |

| <u>Switch 6</u> | <u>Firing Mode</u> |
|-----------------|--------------------|
| OFF | Dual Fire |
| ON | Single Fire |

● STATUS LED FUNCTION

The red status LED is used for verifying system operation and setting timing. When power is turned on, the LED should blink for 1/4 second. If the pickup is near a firing point, the LED will blink, then stay on. This indicates the unit has passed its self test.

If the status LED flashes rapidly when the engine is not running, an over-current or short circuit fault is indicated. Check for proper coil resistance (2.5 to 3.5 ohms) and wiring. Correct the problem, then turn the ignition off for one second, then back on to clear the fault.

As the engine is cranked over, the LED will blink indicating the pickups are generating timing pulses. The pickup is designed such that the LED will come on at about 45 degrees before top dead center and go off at top dead center for each cylinder. This corresponds to the leading edge of the window in the rotating cup (45 BTDC) and the trailing edge (TDC).

● STATIC TIMING THE MOTOR

Remove the timing inspection plug. With the bike in high gear turn the rear wheel to get the crankshaft to top dead center on the **compression** stroke of the front cylinder (TDC mark aligned in the inspection hole). Removing the spark plugs will make it easier to turn the crank.

Rotate the 2000i to cause the status LED to turn off and on. Carefully follow this next instruction: find the point where the LED just turns off while rotating the base plate in a clockwise direction. Lock down the 2000i. The initial timing is now set close to optimum. Final timing may be checked and set dynamically to compensate for normal production tolerances in the timing rotor, camshaft indexing, flywheel marking, etc.

If the 2000i has to be rotated an extreme amount or does not have enough adjustment to bring the timing in, the engine may be on its exhaust stroke. Remove the ignition and observe the timing rotor. The timing pickup (near the switches) should be sitting in one of the windows with the ignition installed. The shorter distance to the other window should be **CLOCKWISE**. If not, rotate the crankshaft 1 revolution and check again.

● DYNAMIC TIMING

To set the 2000i timing dynamically (with the engine running), use the following procedure:

- Set all switches to off and ground the VOES wire. This will cause the ignition to advance 35 degrees by 1500 rpm. Connect a timing light to the front cylinder plug wire.
- Rev the engine above 1500 rpm. The full advance mark should come into view. This will verify the ignition is set properly. Now reset the DIP switches for the mode you want to run.

Note! - when the switch settings are changed, the power to the module must be turned off and back on for the new settings to take effect.

- **VOES/RTD LED FUNCTION**

The green VOES/RTD LED lights when the violet wire is grounded . With the ignition in normal mode and the VOES connected, the green LED will be on most of the time (engine vacuum present). In Retard Mode, the LED can be used to check operation of the retard controller. (See RETARD MODE USING THE VOES WIRE below.)

- **V.O.E.S. SWITCH**

All late model Harley-Davidson engines incorporate a Vacuum Operated Electric Switch (VOES) in the intake manifold to sense engine load. During part throttle operation when manifold vacuum is high (i.e., light engine load), the switch closes, grounding the violet wire and causing the timing to advance more rapidly.

This improves gas milage at cruising speeds and provides crisper part-throttle response while preventing detonation during heavy engine loading.

- **RETARD MODE USING THE VOES WIRE**

This mode provides a convenient ignition retard for nitrous or turbo equipped bikes. When switch 1 is ON, the violet wire acts as a retard trigger. To use this function, the violet wire is connected to a switch or relay that will ground it at the desired time. The violet wire should not be connected a VOES when set for retard mode.

When activated, timing will be limited to 25 degrees regardless which advance curve is selected. When the violet wire is not grounded, timing will follow the quick version of the selected advance curve. The following chart indicates how much retard can be achieved:

| <u>Curve #</u> | <u>Final Timing for Curve</u> | <u>Final Timing with Retard Activated</u> | <u>Total Retard</u> |
|----------------|-------------------------------|---|---------------------|
| 1 | 35 degrees | 25 degrees | 10 degrees |
| 2 | 35 degrees | 25 degrees | 10 degrees |
| 3 | 32 degrees | 25 degrees | 7 degrees |
| 4 | 30 degrees | 25 degrees | 5 degrees |

- **TUNING TIPS - ADVANCED**

Occasionally, best performance may fall somewhere between the curves programmed into the 2000i. By rotating the module clockwise (advanced) or counter-clockwise (retarded), the entire curve will be shifted up or down. Be aware that if you advance the ignition, your final timing will be increased. Excessive advance may cause pinging and hard starting, so only turn the 2000i one or two degrees at a time and note any changes to the motor.

For racing applications, the advance can be set to always come in quickly by using NORMAL VOES mode and permanently connecting the violet wire to ground. These curves are similar to what is generated by a mechanical advancer.

For heavy bikes or built motors that tend to detonate, the advance can be brought in more slowly. If the VOES wire is left unconnected, the advance will always follow the slower rpm curve shown on the graph.

**SINGLE-FIRE/DUAL-COIL
WIRING DIAGRAM**

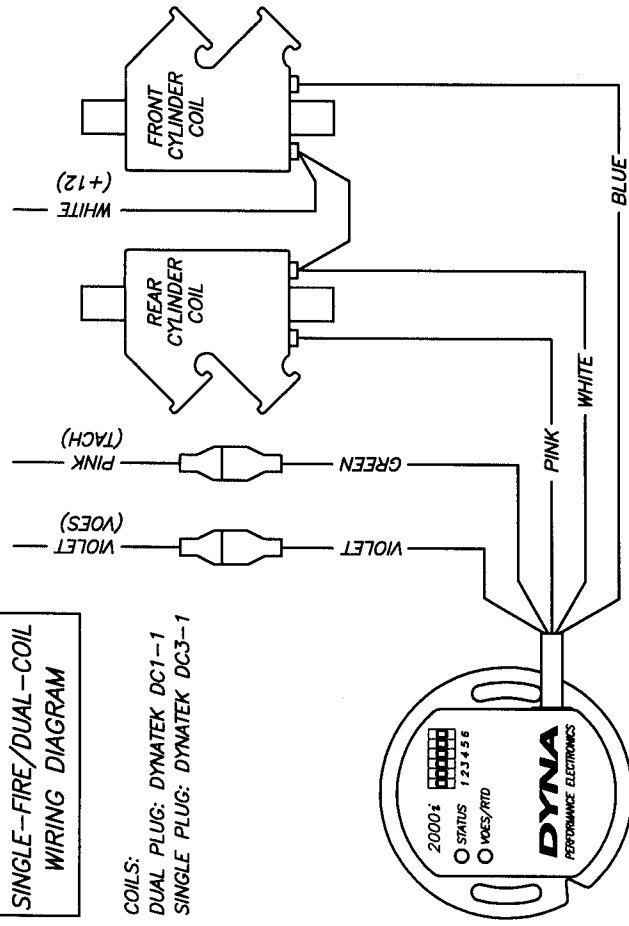

**SINGLE-FIRE/SINGLE-COIL
WIRING DIAGRAM**

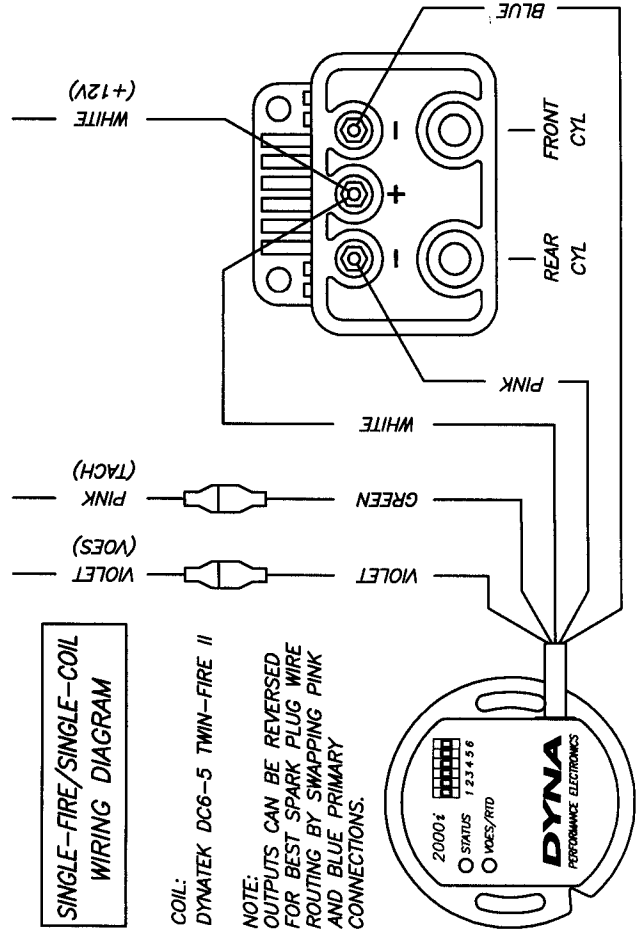

**DUAL-FIRE/SINGLE-COIL
WIRING DIAGRAM**

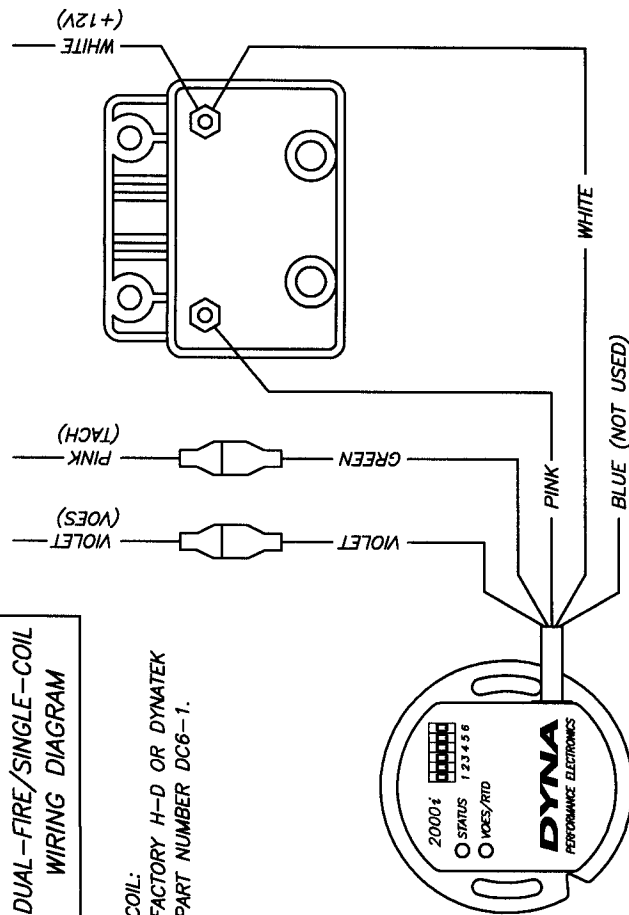

**DUAL-FIRE/DUAL-COIL
WIRING DIAGRAM**

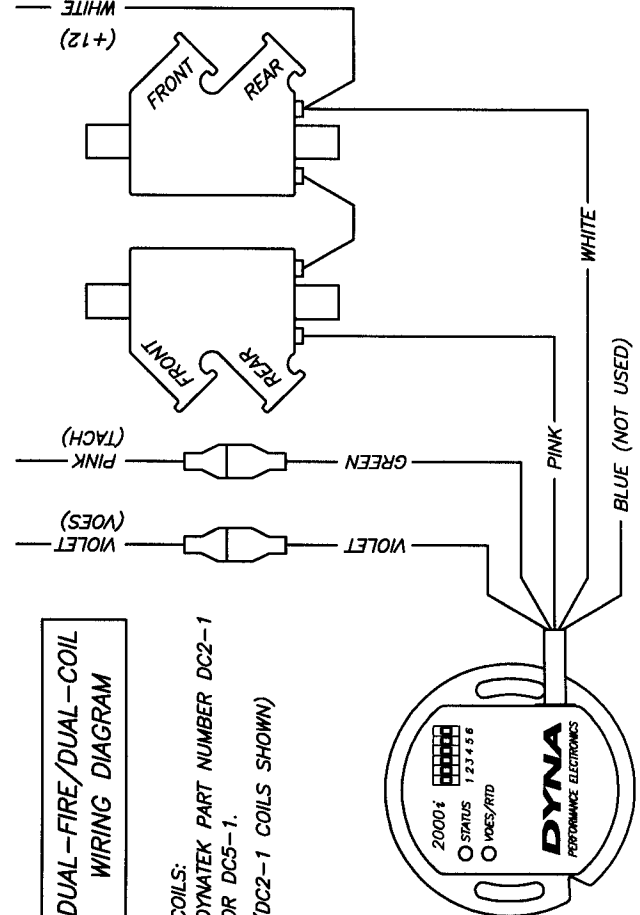

NORMAL VOES MODE ADVANCE CURVES

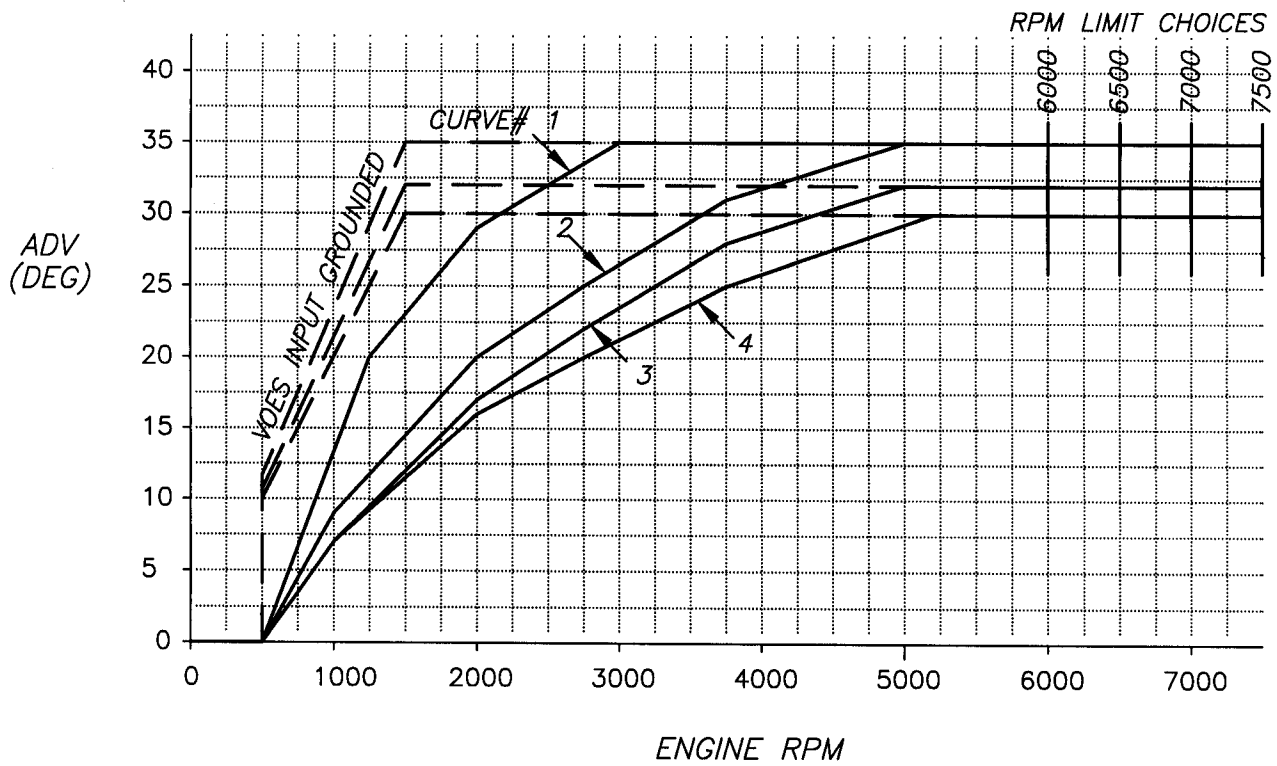

RETARD MODE ADVANCE CURVES

