



# INSTALLATION

## HYPERCHARGER AIR CLEANER KIT

## 9400

### PARTS INCLUDED

- 1 Hypercharger with K&N Filter
- 1 Adapter Hardware Kit Contains the Following:
  - 1 Rubber Intake Duct with Rubber Carb Bumper
  - 1 Main Support Bracket
  - 1 Carb Bumper Bracket
  - 1 18" Length of 5/32" Rubber Hose
  - 1 3-way Barbed "T" Fitting
  - 3 1/4"-20 X 5/8" Socket Head Cap Screw
  - 5 1/4"-20 Nylock Nut
  - 2 1/4"-20 X 1/2" Button Socket Cap Screw
  - 2 1/4" Flat Washer
  - 2 Step Reducer Washer
  - 1 90 Degree Elbow
  - 1 6" Length of 3/8" Rubber Hose
  - 4 Hose Clamp
  - 2 3/8" Barbed Nylon Connector
  - 2 M6 X 1.0 X 16mm Hex Head Cap Screw
  - 2 M6 Flat Washer
  - 1 Gray Vinyl Cap
- 1 Jet Kit Includes the Following Ten Items:
  - 1 5/32" Drill Bit
  - 1 # 50 Drill Bit
  - 1 132 Main Jet
  - 1 135 Main Jet
  - 1 138 Main Jet
  - 1 140 Main Jet
  - 1 Needle
  - 1 E-Clip
  - 2 .020 Needle Shim
  - 1 Slotted Pan Screw
- 1 Installation Instructions

Please read and understand entire instructions before starting installation.

### THANK YOU FOR CHOOSING KÜRYAKYN!

**IN ORDER TO PROTECT YOU AND OTHERS FROM POSSIBLE INJURY AND/OR PROPERTY DAMAGE OR LOSS, PLEASE PAY CLOSE ATTENTION TO ALL INSTRUCTIONS, WARNINGS, CAUTIONS AND ATTENTION NOTES REGARDING THE USE AND CARE OF THIS PRODUCT.**

**WARNING!** THIS INDICATION ALERTS YOU TO THE FACT THAT IGNORING THE CONTENTS DESCRIBED HEREIN CAN RESULT IN POTENTIAL DEATH OR SERIOUS INJURY.

**ATTENTION!** This indication alerts you to the fact that ignoring the contents described herein may negatively affect product performance and functionality.

**CAUTION!** This indication alerts you to the fact that ignoring the contents described herein can result in potential injury or material damage.

-cont.-

9400-25MC-1011



### CUSTOMER SERVICE

877.370.3604 (toll free)

### INSTALLATION QUESTIONS

techsupport@kuryakyn.com  
or call 715.247.2983

### LIMITED WARRANTY

Küryakyn warrants that any Küryakyn products sold hereunder, shall be free of defects in materials and workmanship for a period of one (1) year from the date of purchase by the consumer excepting the following provisions:

- Küryakyn shall have no obligation in the event the customer is unable to provide a receipt showing the date the customer purchased the product(s).
  - The product must be properly installed, maintained and operated under normal conditions.
  - Küryakyn makes no warranty, expressed or implied, with respect to any gold plated products.
    - Küryakyn shall not be liable for any consequential and incidental damages, including labor and paint, resulting from failure of a Küryakyn product, failure to deliver, delay in delivery, delivery in nonconforming condition, or for any breach of contract or duty between Küryakyn and a customer.
- Küryakyn products are often intended for use in specific applications. Küryakyn makes no warranty if a Küryakyn product is used in applications other than intended.
- Küryakyn electrical products are warranted for one (1) year from the date of purchase by the consumer. L.E.D.'S contained in components of Küryakyn products will be warranted for defects in materials and workmanship for 3 years from the date of purchase where as all other components shall be warranted for one(1) year. This includes, but is not limited to; control modules, wiring, chrome & other components.

• Küryakyn makes no warranty of any kind in regard to other manufacturer's products distributed by Küryakyn. Küryakyn will pass on all warranties made by the manufacturer and where possible, will expedite the claim on behalf of the customer, but ultimately, responsibility for disposition of the warranty claim lies with the manufacturer.

### ABOUT OUR CATALOG

For purchasing Küryakyn® products, you can receive a complete catalog free of charge. Send the Proof-of-Purchase below with your address to: Küryakyn, P.O. Box 339, Somerset, WI 54025. Please indicate either Accessories Catalog for Harley-Davidson® or GL & Metric Cruisers.

Be sure to ask your local dealer about other Küryakyn® products, the motorcycle parts and accessories designed for riders by riders.

©2005 Küryakyn USA® All Rights reserved.

kuryakyn.com



**TOOLS SUGGESTED**

Set of Metric and Standard Hex wrenches, Set of Metric and Standard Combination Wrenches, the Bike's Tool Kit, Metric Socket Set, Small Vice Grip, Silicone, Phillips Screw Driver, Needle Nose Pliers, Small Flat Tip Screwdriver, Diagonal Cutter, Drill and a Service Manual for this Motorcycle.

**STRICTLY OBSERVE THE FOLLOWING GUIDELINES IN ORDER TO USE THE PRODUCT PROPERLY AND AVOID POTENTIALLY DANGEROUS ACCIDENTS.**

**STEP 1** Read and understand all steps in the instructions before starting the installation. Park the motorcycle on a hard, level surface and turn off the ignition. Let cool.

**DISCLAIMER — PLEASE READ BEFORE PROCEEDING**

**Any modifications to a motorcycle's exhaust or intake tract require carburetor re-jetting to achieve maximum performance and maintain drivability. If you are uncomfortable with the process of tuning your carburetor, we recommend that you bring your motorcycle to a qualified motorcycle mechanic to have this kit installed. The jets included in this kit were selected based on test results with various combinations of components that we felt would represent the majority of the customers purchasing this kit. However, no two motorcycles are exactly alike. Depending on the individual case, additional jets may need to be purchased from an outside source. Küryakyn warrants the parts included in this kit to be free of defects in materials and workmanship, but makes no claim whatsoever in regard to costs associated with installation or tuning.**

**WARNING!** YOU WILL BE WORKING AROUND THE ENGINE AND EXHAUST SYSTEM DURING INSTALLATION. ENSURE THAT THE ENGINE AND EXHAUST SYSTEM HAVE FULLY COOLED TO PREVENT INJURY.

**ATTENTION!** A factory service manual may be helpful in performing this installation. Do not attempt to perform this installation if you are not confident in your ability to complete all of the steps in the procedure; consult a trained technician.

**CAUTION!** The installation of any high performance exhaust system can cause a "lean" fuel/air mixture. A "lean" fuel/air mixture can cause engine overheating resulting in severe engine damage. Küryakyn recommends rejetting carbureted bikes.

**STEP 2** Remove the seat.

**STEP 3** Remove the bottom of the three dash plaque bolts (8mm).

**STEP 4** Lift up on the dash panel and unscrew the speedometer cable (knurled nut).

**STEP 5** Unplug the three electrical connections.

**STEP 6** With a 12mm socket, remove the tank-mounting bolt under the dash and at the rear of the tank.

**STEP 7** Close the fuel valve and clamp off the fuel line. Disconnect the line from the fuel valve.

**STEP 8** Raise the rear of the tank, and disconnect the two vent hoses, and remove the tank.

**STEP 9** Refer to the section of your factory service manual that deals with removal and installation of the following components:

- Remove the two round chrome "air cleaner covers", their backing plates, the stock black plastic air box (air inlet under tank), and the crossover tube.
- Remove the intake manifold to remove and crossover tube. Use extreme care when replacing the intake manifold. Uneven torque, damage to the intake gaskets, or contamination can cause an intake leak that will result in very poor running, and nearly impossible jetting!!
- Unplug all hoses or lines from these components. You may want to label these hoses at this time. The Largest of these hoses (3/4" I.D.) is for the fresh air injection system; the second largest (3/8" I.D.) is the crankcase breather. The smallest of the hoses is a drain.

-cont.-

**STEP 10** Remove the brackets that held each round backing plate. The right hand bracket is also a carb stabilizer. This function is duplicated with one of the included brackets.

**STEP 11** Remove the carburetor according to the section in your factory service manual that outlines procedures for carburetor removal, disassembly, reassembly and installation. We recommend that you label each hose or fitting as they are removed to make reassembly easier. An example of hose labeling is shown in PIC.1.

**CARBURETOR RE-JETTING PROCEDURE**

**NOTE: Different combinations of aftermarket exhaust and air cleaners will have a significant impact on carburetor jetting. The supplied jetting components have been tested and found to be a good combination to produce drivability and performance with stock or free flowing, muffled/baffled exhaust pipes. We highly recommend NOT using drag pipes (open style). Using drag pipes in conjunction with our air cleaner will require additional jetting above and beyond the components included in this kit.**

**A)** Consult your factory service manual for details of this procedure. We have supplied jets to cover many common configurations. Remove the four Phillips head screws securing the plastic carb top to the carb body. Carefully remove the plastic carb top making sure not to damage the rubber diaphragm.

**B)** Carefully remove the diaphragm and slide from the carb.

**C)** Remove the spring, plastic retainer and needle from the slide.

**D)** See FIG.1. Very carefully drill out the slide lift hole with the included .070 drill bit. Be sure to remove all filings from drilling. Place the small E-Clip in the third groove from the top of the needle, See FIG.2. Stack two .020 shims on top of the E-Clip. The shims will keep the needle from bouncing in the slide.

**E)** Carefully replace the needle/slide assembly into the carb body. Place the stock plastic retainer over the end of the needle and shims. The retainer should gently seat over the shims. Place the spring over the retainer. Carefully seat the lip of the diaphragm in the corresponding groove in the carb body. **DO NOT FOLD, PINCH, TEAR OR PUNCTURE THE DIAPHRAGM!!** Replace the top cover.

**F) READ THIS ENTIRE STEP BEFORE PROCEEDING!** See FIG.3. Turn the carb upside down. Using the supplied 5/32" drill bit, slowly drill out the plug covering the idle mixture screw. The mixture screw is made of brass. If you drill to far you will destroy the slot in the adjustment screw making adjustment impossible. Once the hole is drilled, start the supplied slotted pan screw into the drilled hole just far enough for the threads to "bite". Grasp the head of the screw with a pliers and pull outward in a slight rocking motion until the plug comes free.

**G)** Using a small flat head screwdriver, slow and gently turn the adjustment screw inward (clock-wise) until it lightly bottoms out. Once lightly bottomed out, back the adjustment screw outward (counter clock-wise) three full turns.

**H)** Remove the four Phillips head screws that secure the float bowl to the carb body. Remove the float bowl being extremely careful no to disturb the position of the float.

**I)** Replace the stock low speed jet with the supplied #48 jet. Replace the stock main jet with the supplied #135 jet.

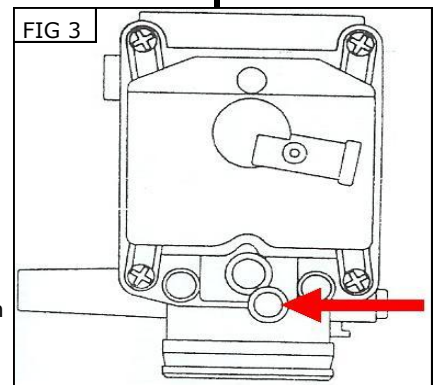
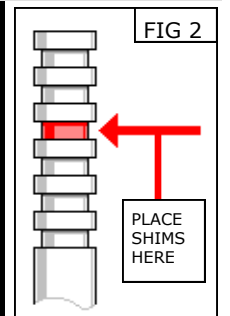
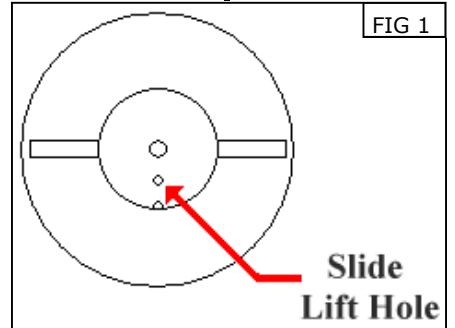
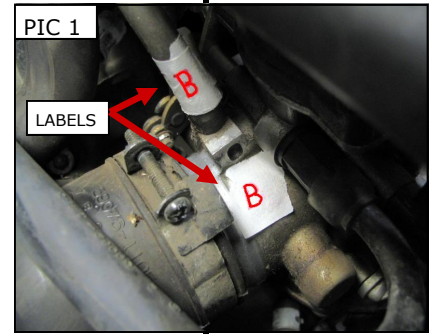

**CARBURETOR TUNING TIPS**

- Run the bike until it reaches operating temperature. Adjust the idle mixture screw until the bike reaches it's highest idle speed. Reset the idle speed with the idle adjustment knob.
- If further tuning is required, let your spark plugs be your guide. A white or uncolored plug indicates a lean condition while a black or sooty plug indicates a rich condition.
- Be sure you're working with the correct jet. The low speed (pilot jet) affects throttle positions of about 1/8 open to approximately 1/3 open. The main jet affects throttle positions of about 3/4 open to wide open. Needle position affects most throttle settings in between. In other words, don't change the main jet if you are experiencing a lean condition just off idle.

-cont.-

- Generally speaking, popping of backfiring through the carb indicates a lean condition. Blubbering, smoking or popping out the exhaust indicates a rich condition.
- If you are experiencing backfiring through the exhaust, check the following before you assume the carburetor is improperly jetted:

- A)** Leaking exhaust pipe gaskets
- B)** Leaking fresh air system block off plate gaskets (if applicable)
- C)** If the fresh air system was not removed, be sure the plug has not come out of the 3/4" inlet hose.

**STEP 12** Reinstall the carburetor according to the section in your factory service manual that outlines procedures for carburetor removal, disassembly, reassembly and installation.

**STEP 13** Insert the supplied rubber intake duct through the main support bracket making sure both flanges are through the support bracket as shown in PIC.2.

**STEP 14** Install the 90-Degree Elbow into the threaded hole in the Hyper back plate located at the rear section (pointed end).

**STEP 15** Insert the "flanged" end of the rubber carb bumper through the opening in the center of the chrome carb bumper bracket. You will need a small flat head screwdriver to push it through. The "knob" should protrude through the bracket in the opposite direction as the two mounting tabs at each end of the bracket. See PIC.3.

**STEP 16** Mount the bumper bracket to the carb support bracket as shown in PIC.4, using the 1/4-20 x 5/8" button head cap screws, reducer washers, 1/4" flat washers, and Nylock nuts. When positioned correctly, the rubber carb bumper will be positioned directly between the two vertical, parallel flanges on the carb body once the assembly is mounted to the engine.

**STEP 17** Remove the round Trap Door from the front of the Hyper by removing the four Button Socket Cap Screws using a hex wrench.

**STEP 18** The front cover of the Hyper has been removed for clarity in the picture but it is not necessary for the installation. Insert the rubber intake duct through the Hyper back plate in the same fashion it was installed in the main support bracket. See PIC.5. You may need to use a screwdriver to help "poke" the flange of the Rubber Intake Boot into position inside the back plate.

**STEP 19** See PIC.5. Roll back the inner "lip" of the rubber intake duct, align the mounting holes in the Hyper back plate, rubber intake duct and support bracket and insert a supplied 1/4"-20 x 5/8" Socket Head Cap Screw through each hole. Secure on the bracket side of the assembly with the supplied 1/4"-20 Nylock Nuts. Tighten snugly.

**STEP 20** Replace the trap door in reverse fashion as removed in STEP 17.

**STEP 21** Remove the large hose clamp from the OEM rubber air cleaner boot, (air cleaner to carburetor connection) and install it on the carb end of the new rubber intake duct.

**STEP 22** Locate the vacuum line shown in PIC.6 located at the left, front side of the carb. Cut the vacuum line about three inches from the carb and insert the supplied "T" fitting as shown. Connect one end of the supplied 18" hose to the remaining outlet on the "T" fitting and route the other end downward on the forward side of the carburetor. This end will be connected in a later step.

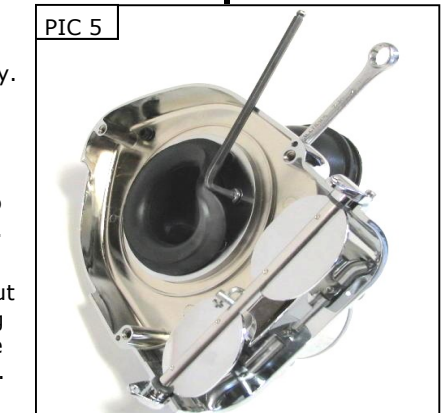
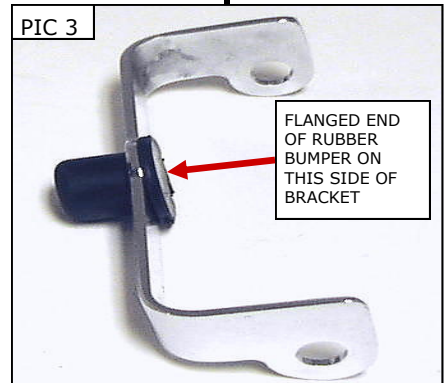

**STEP 23** Insert one of the supplied 3/8" double ended hose barbs into each end of the supplied section of 3/8" hose and secure them in place using the supplied hose clamps. Insert one end of the hose and barb assembly into the breather port located at the bottom of the rubber intake duct and secure it using a supplied hose clamp.

**STEP 24** Hold the Hypercharger assembly in position. Slide the rubber intake duct over the mouth of the carb and secure the mounting bracket to the cylinders with the M6 Hex Head bolts and flat washers provided. Tighten the hose clamp around the mouth of the carb.

**STEP 25** Route the loose end of the hose and barb assembly installed in STEP 23 to the crank case breather hose previously connected to the OEM right side air cleaner back plate and secure using the remaining hose clamp.

**STEP 26** Connect the open end of the 1/4" hose installed in STEP 22 to the vacuum nipple located at the bottom of the vacuum pod on the inner front portion of the hyper back plate.

**STEP 27** See PIC.7. The float bowl vent hose is connected to the left rear of the carb. Remove this hose from the bike and cut four inches off of the end that was previously connected to the carburetor. Reconnect the cut end of the hose to its original location. Route the vent hose downward under the carb and connect it to the 90 Degree Elbow that was installed in the back plate of the hyper. See STEP 14.

**CAUTION!** If the float bowl vent hose is pinched or kinked your bike will not run properly!

**STEP 28** See PIC.8. Insert the supplied Gray Vinyl Cap in to the fresh air inlet hose that was connected to the crossover tube. You may choose to spread a thin layer of silicone inside the hose to help secure the cap inside the hose.

**STEP 29** Reinstall the air box.

**STEP 30** Work backwards from STEP 8 to STEP 2 to complete the installation.

**STEP 31** **Double check the tightness of all related fasteners, check for hose clearance and check throttle for correct operation, making sure it returns properly, before starting the bike.**

**ATTENTION!** It is the installer's responsibility to ensure that all of the fasteners (including preassembled) are tightened before operation of the motorcycle. Küryakyn will not warranty components lost due to improper installation. Periodic maintenance may be required.

