



INSTALLATION INSTRUCTIONS
TRAILER HITCH
FOR FLSTC, FXST
Mfg. p/n 720600D
(See pkg. label for Dist. p/n)

ATTENTION INSTALLER (if other than owner):
Please forward this instruction sheet and the warranty card to the purchaser of this product. These instructions also contain valuable information necessary to the end user.

INTRODUCTION:

These instructions describe the procedure for properly installing KHRÔME WERKS® Trailer Hitch onto 1986-up FLSTC and 1986-1999 FXST models (not FLSTF, FLSTS or FLSTN models). Review instructions carefully before beginning, as they contain important information. Please retain for future reference.

Particularly important information is distinguished in these instructions by the following notations:

NOTE: A NOTE provides key information to make procedures easier or clearer.

CAUTION: A CAUTION indicates special procedures that must be followed to avoid damage to the motorcycle or accessories.

WARNING: A WARNING indicates special procedures that must be followed to avoid injury or death to a motorcycle operator or person inspecting or repairing the motorcycle.

TOOLS REQUIRED:

- | | |
|------------------------------|--------------------------------|
| 1 . 3/4+combination wrench | 1 . 7/32+hex key wrench |
| 1 . 9/16+combination wrench | 1 . 5/32+hex key wrench |
| 2 . 1/2+combination wrenches | 1 . #4 posi-driver screwdriver |
| 1 . 7/16+combination wrench | 1 . 1/8+combination wrench |
| 1 . 3/8+hex key wrench | 1 . #50 Torx key wrench* |
- *2000 and later models only

PROCEDURE:

- NOTE:**
- Will not fit FLSTF, FLSTS or FLSTN models
 - Will not fit 2000-2005 FXST (unless rear turn signals are relocated to the second mounting hole from the rear using a post-style turn signal pin and the proper length spacer. Follow instructions for FLSTC models if this modification is made.)
 - Installation of this hitch requires frame mount exhaust support bracket.
 - Will not fit with OEM and similar style rear dresser bar.
 - Khrôme Werks® rear Dresser Bar, p/n 190050B, is specifically designed for this application.
 - Will not fit with models equipped with OEM fringed saddlebags.

WARNING: Remove axle caps if motorcycle is so equipped. They will not clear.
1. Remove saddlebags if so equipped.

NOTE: 1990-up FLSTC has a front saddlebag support. When installing Trailer Hitch only and not Khrôme Werks® rear Dresser Bar, p/n 190050B, OEM supports can be used. When installing Khrôme Werks® rear Dresser Bar, supports will not be required.

2. Remove passenger footrests and/or floorboards. Save footrests (and/or floorboards), washers and/or nuts (99 and earlier models). Discard bolts. On models equipped with passenger floorboards; 99 and earlier, remove nut from stud on inside of frame; 2000-up FLSTC, remove socket head screw from floorboard mount. Save hardware.

3. 86-99 MODELS: Remove Phillips oval head screw from rear of fender strut. Discard screw and save any other hardware. 2000-up FLSTC: Remove chrome hole plugs in rear hole of struts.

NOTE: If equipped with turn signal relocation kit, OEM p/n 65848-87A for FXST models, remove 3/8+mounting bolt. Supplied bolt will work with relocation kit.

4. 99 and EARLIER MODELS: Install 3/8+buttonhead screws and washers (items 1,2) through top of vertical supports (item 3) and into fender supports. Use original hardware on inside of fender. Finger tighten only.

2000-up FLSTC: Loosen fender strut. Install the set screw (item 4) through the rear hole in the fender strut and into the 5/16+18 nut (item 5) behind the strut. Hold the nut temporarily in place with a slender, pencil-type magnet. Screw it in only until it is fully engaged. Install the vertical supports (item 3) with the flange nuts (item 6). Hold the set screw from rotating with the 5/32+hex key wrench. Make sure the set screw is fully engaged in both nuts. Finger tighten.

NOTE: ALL MODELS: The vertical supports are correctly installed when the welded tube-to-plate joint faces the inside of the bike. See the illustration.

5. Attach the horizontal supports (item 7) to inside of frame at footrest mount. Right horizontal support has tabs used to mount anti-sway brace to muffler support. Right side of motorcycle is exhaust side. Spacer (item 8) goes between frame and front mounting tab. Spacer is left out if OEM saddlebag relocation kit, OEM p/n 90345-90A, or if Khrôme Werks® rear Dresser Bar is installed on motorcycle.

99 and EARLIER MODELS: Install 1/2-20 x 1 3/4 bolt (item 9) and factory washer through hitch, spacer (if applicable), frame, front lower saddlebag support bracket and into foot peg. Mount using floorboard stud and nut if so equipped. Finger tighten.

2000-05 FLSTC: Install supplied 3/8+16 x 2 1/2 bolts (item 10), first through the foot peg post, then through the frame, the spacer (if applicable) and the hitch. Loosely install 3/8+washer and 3/8+16 bi-way nut (items 11,12).

2006-up FLSTC: Installed supplied 3/8+16 x 3 1/2+bolts (item 10), following instructions for 2000-05 models.

NOTE: Due to thread length variance on available fasteners the nut may bottom before tightening properly. If this occurs, the frame threaded portion needs to be drilled out with a 3/8+or 25/64+drill bit. The foot peg and the hitch will be secured by the nut, similar to the 1986-99 version bikes.



INSTALLATION INSTRUCTIONS

TRAILER HITCH FOR FLSTC, FXST Mfg. p/n 720600D

(See pkg. label for Dist. p/n)

CAUTION: Many accessories mount in this location. Make sure bolt/screw or stud is of adequate length to safely mount footrest/floorboard. General rule: 1 ½ times of thread diameter engagement for blind fastening and at least one thread should be showing through nuts. Make sure fastener is not too long and that it doesn't bottom out before tightening.

WARNING: Foot pegs must fold up at a 45° angle (from vertical) toward rear of motorcycle. This angle allows foot pegs to fold up if, by accident, they strike the ground surface when making a sharp turn. Failure to set foot pegs to the proper fold-up angle could result in death or serious injury. «

« Harley-Davidson Motor Company July 1999

6. Slide Trailer Hitch weldment (item 13) onto horizontal supports and line up four holes. Install four ¼+buttonhead screws (item 14) through weldment, horizontal and vertical supports and start ¼+bi-way nuts (item 15) onto screws.

7. 99 and EARLIER MODELS: Install the end of the anti-sway brace with the 5/16+hole, offset facing out (item 16 for 86-94 models, item 17 for 95-99 models), to the inside tab of the right horizontal support using the 5/16+18 x ¾+hex bolt, flat washers, and nut (items 18, 19, 20). Attach the slotted end to the inside of the rear boss of the OEM muffler support bracket with the 5/16+18 x 1+hex bolt, flat and lock washers (items 19, 21, 24). Finger tighten.

WARNING: Check clearance of upper bolt end to caliper body. Brake caliper moves outboard as pads wear.

2000-up FLSTC: This step is easier if the rear muffler is removed. Install the 1 3/16+clamp (item 22) around the exhaust hanger/crossover tube just under the rear tab on the right horizontal support. Squeeze the clamp ends together as close as possible. Install the slotted end of the short sway brace (item 23) to the inside of the tab on the horizontal support using the 5/16+18 x 1+bolt, washers and nut (items 19, 20, 24). Attach the clamp to the outside of the sway brace using the 1+bolt, washers and nut (items 19, 20, 24). The clamp and brace will come into alignment when the hardware is tightened.

WARNING: The supplied anti-sway brace (or equivalent) MUST be installed to ensure proper handling when towing.

8. Align Trailer Hitch to motorcycle and tighten all hardware securely.

9. Install trailer hitch ball, bolt and lock washer (item 25) onto hitch tongue. Torque to 260 ft-lb (dry).

WARNING: Make sure bolt doesn't bottom in ball before torque spec is achieved.

10. Install saddlebags if so equipped.

WARNING: Check for clearance between all moving parts. Hitch must not hit or run on any moving parts, i.e., swing arm, drive pulley, axle, brakes, wheel, exhaust, saddlebags, etc.

USE AND CARE: Wash your accessories with the same care you use when washing your motorcycle. Use mild soap and water. DO NOT use abrasive chemicals or cleaners, or high pressure washers.

BILL OF MATERIALS

Item#	Mfg. P/N	Description	Qty.
1	433447	Screw, skt buttonhead, 3/8+24 x 1 ½+	2
2	420291	Washer, 3/8+flat chrome	2
3	720604	Vertical Support, left	1
	720605	Vertical Support, right	1
4	434409	Screw, socket set, 5/16+18 x 1+	2
5	420025	Nut, 5/16+18 hex	2
6	420080	Nut, 5/16+18 hex flange	2
7	720616	Horizontal support, left	1
	720617	Horizontal support, right	1
8	439044	Spacer, 1+x .5+x .25+zinc	2
9	420768	Screw, hex cap, ½%20 x 1 ¾+	2
10	430529	Screw, socket head, 3/8+16 x 2 ½+	2
	430534	Screw, socket head, 3/8+16 x 3 ¼+	2
11	420286	Washer, 3/8+flat zinc	2
12	420066	Nut, 3/8+16 bi-way	2
13	720601B	Trailer Hitch weldment	1
14	433445	Screw, skt buttonhead, ¼+20 x 1 ½+	4
15	420064	Nut, ¼+20 bi-way	4
16	720608	Anti-sway brace 1986-94 (5 13/32+L)	1
17	720619	Anti-sway brace 1995-99 (6 3/16+L)	1
18	420466	Screw, hex cap, 5/16+18 x ¾+	1
19	420285	Washer, 5/16+flat zinc	4
20	420065	Nut, 5/16+18 bi-way	2
21	420225	Washer, 5/16+lock	1
22	203008	Clamp, 1 3/16+	1
23	720618	Anti-sway brace 2000-up	1
24	420467	Screw, hex cap, 5/16+18 x 1+	2
25	7081043	Ball w/ ¾+10 x 1 ¾+bolt and washer	1

KHROME WERKS®

div. D.S. Manufacturing, Inc. • 67 Fifth St. N.E. • Pine Island, MN 55963



INSTALLATION INSTRUCTIONS
TRAILER HITCH
FOR FLSTC, FXST
Mfg. p/n 720600D
(See pkg. label for Dist. p/n)

Optional Chrome Trailer Hitch Receptacle
80-96 Five-pin male/female connector
and wiring included. Available under p/n 720557

97-10 Five-pin male female connector with
Plug-n-play wire harness. Available under p/n 720585

97-10 Five-pin male female connector with
Plug-n-play isolator relay/wire harness. Available under p/n 720582

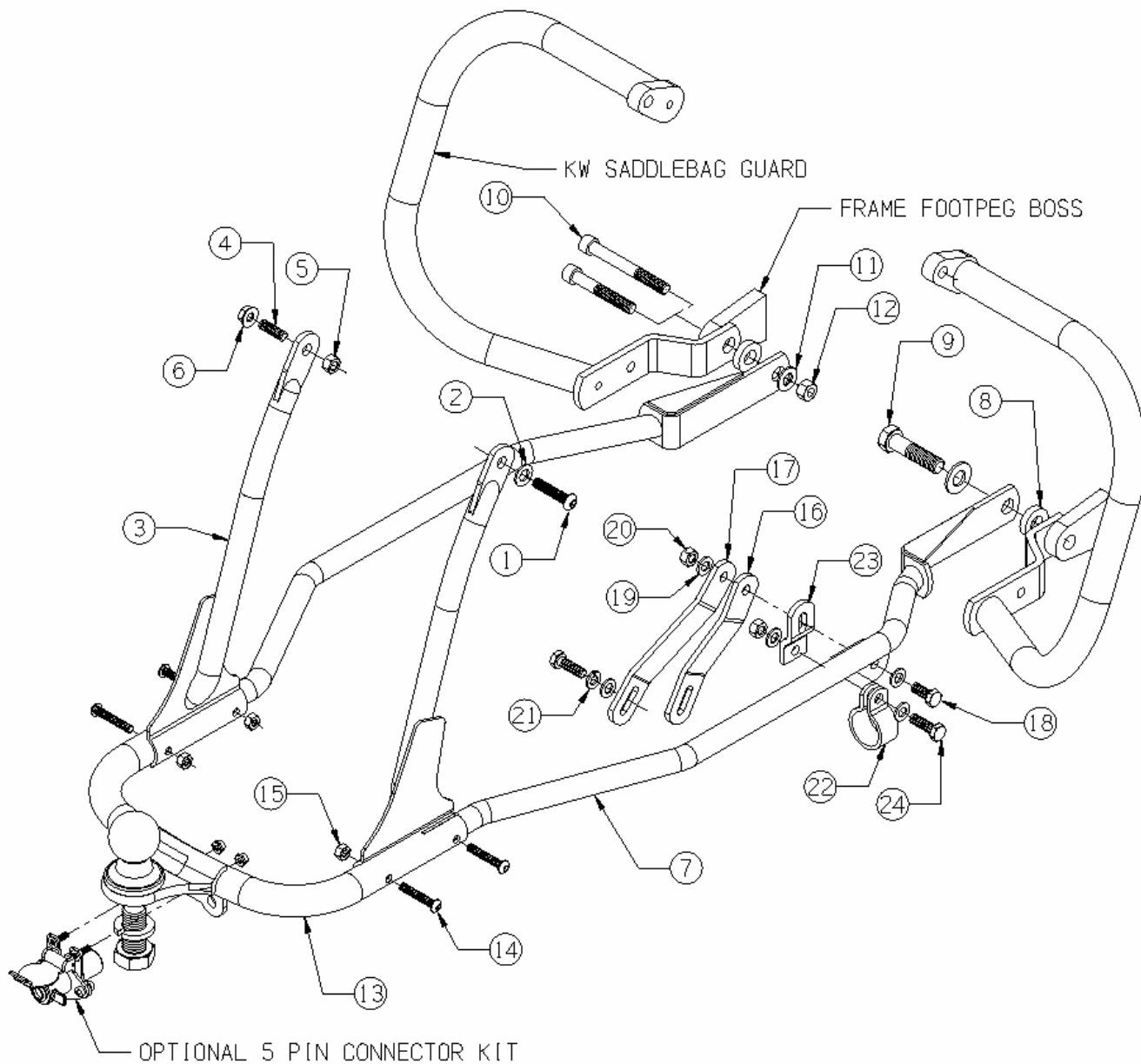

KHROME WERKS®
div. D.S. Manufacturing, Inc. • 67 Fifth St. N.E. • Pine Island, MN



INSTALLATION INSTRUCTIONS

TRAILER HITCH
FOR FLSTC, FXST
Mfg. p/n 720600D

(See pkg. label for Dist. p/n)

W A R N I N G S

For all-around best handling of motorcycle, tongue weight should be 10% of the gross weight of the trailer, but maximum tongue weight cannot exceed 40 lbs.

NOTE: Gross weight includes weight of trailer and all its contents, not to exceed 400 lbs.

REMEMBER:

A. Tow only those trailers equipped with a 1 7/8+coupler to match the 1 7/8+ball supplied with the hitch. We recommend only trailers from reputable suppliers, designed for motorcycle towing, and with a proven history of good handling. Towing a trailer with poor handling can result in severe injury or death from an accident.

B. When connecting to trailer, always make sure ball is tight on hitch, and that coupler is tight on ball. When connecting to trailers equipped with hand wheel couplers, hand-tighten only. Do not tighten with a wrench. Periodically, check these areas for tightness.

C. Always use approved safety chains, and have them securely attached. Cross the safety chains under the tongue of the trailer so that the tongue will not drop to the road if it becomes separated from the hitch. Always leave just enough slack so that you can turn with your rig. And, never allow safety chains to drag on the ground.

D. Trailer tire pressure should be inflated to maximum allowable pressure, unless otherwise recommended by the trailer manufacturer. Rear motorcycle tire pressure should be inflated to maximum allowable pressure (refer to tire side wall marking) and checked periodically.

E. Towing a trailer requires a certain amount of experience. Before setting out on an extended ride, get to know your rig. Check the trailer hitch, coupler, safety chains, electrical connector, lights and tires. After loading the trailer, weigh the trailer and then the tongue, separately, to see if the weights are proper. If not, you may be able to get them right by simply shifting the items around in the trailer. When pulling a trailer with a motorcycle, extra distance must be allowed for stopping, and a slower speed when cornering must be used. The motorcycle and trailer combination is now longer, so allow more passing distance. Reduce speed when traveling downhill (may have to downshift). Use extra caution and don't exceed your riding capabilities. During the trip, check occasionally to be sure that the load is secure, and that the lights are still working.

F. The coupler is susceptible to physical damage when trailer is parked. Prop tongue off ground when trailer is not in use. Carefully inspect coupler for damage or missing parts before each hook-up.

G. If trailer sways or bounces while towing, SLOW DOWN BY REDUCING SPEED GRADUALLY and STOP TOWING immediately. Unless cause can be determined, i.e., shifted load, etc., which can be corrected, do not resume towing.

H. If motorcycle is involved in an accident or spill, with or without trailer attached, hitch must be inspected for physical damage before towing.

I. Periodically, check tightness of all hardware relating to trailer hitch assembly and trailer.

KHROME WERKS®

div. D.S. Manufacturing, Inc. • 67 Fifth St. N.E. • Pine Island, MN