

## Items Supplied >

1 - INTAKE COVER ASSEMBLY  
1 - K&N® VENTURI AIR FILTER  
1 - BASE MOUNTING PLATE  
1 - BILLET VELOCITY STACK  
1 - SUPPORT BRACKET  
1 - INTAKE GASKET  
2 - O-RING, SILICONE  
2 - BREATHER HOSE, SPORTSTER  
2 - BREATHER BOLT, 1/2"-13 X 1"  
3 - BOLT, 1/4"-20 X 7/8", BUTTONHEAD W/ LOCK PATCH  
3 - LOCK WASHER, 1/4" TOOTHED  
3 - BOLT, 1/4"-20 X 2-3/4", 12 POINT HEAD W/ LOCK PATCH

3 - SPACERS

## Application(s) >

HARLEY:  
SPORTSTER 2004 - 2017

## Instruction Manual >

606-0103-05/05B/05BC/05CB

Page 1 of 2

**Read all instructions carefully and completely before installing your new RACE PRO™ Intake.**

1. Remove the (2) allen bolts from the center of the stock air cleaner to remove the cover. Remove the (3) bolts securing the air filter. Remove the stock (2) breather bolts from the cylinder heads. Discard the air box, air filter, hardware and seals/gaskets.  
*NOTE: Some California models will have a charcoal canister vent tube that must be disengaged before removing air box. Remove and save the vent tube grommet from the stock air box.*
2. Place the supplied o-rings onto both supplied breather bolts. Insert the breather bolts through the openings in the supplied support bracket and begin threading into the cylinder heads. Insert the supplied gasket between the support bracket and throttle body and line up all the holes, then snug the breather bolts, but do not fully tighten.
3. Insert the (2) supplied breather hoses through the mounting plate and into the velocity stack with the hoses rotated outward, as shown in **FIGURE 1**. Make sure the breather hoses are bottomed out in the back of the velocity stack.  
*NOTE: California models will need to install the vent tube grommet into the designated hole in the mounting plate, see **FIGURE 1**.*
4. Insert (3) supplied 1/4"-20 x 7/8" buttonhead bolts with lock washers through the mounting holes in the velocity stack and base mounting plate, then position on top of the installed support bracket (Step 2), and start threading the buttonhead bolts into the throttle body, but do not tighten. See **FIGURE 1**.
5. Snug the (3) buttonhead bolts evenly, and then fully tighten them to the throttle body. Fully tighten the (2) breather bolts from Step 2.
6. Insert outer end of rubber hoses over nipples on breather bolts.  
*California Models: Insert the charcoal canister vent tube through the grommet installed in Step 3.*
7. Place the supplied K&N® filter onto the velocity stack.
8. Place the RACE PRO intake cover over the air filter so that there is a 12-point bolt centered between the top two mounting holes. See **FIGURE 2**.
9. Insert the 2-3/4" long 12-point bolts through the 3 outer holes in the intake cover and through the spacers to the base mounting plate threaded holes. See **FIGURE 2**. Snug the (3) bolts evenly until the intake cover tightens down onto the spacers. Then tighten the bolts securely.

\* Cobra® recommends you always wear a helmet while riding. Please never operate your motorcycle while under the influence of alcohol and/or drugs. Enjoy the new look of your motorcycle and please ride safely.

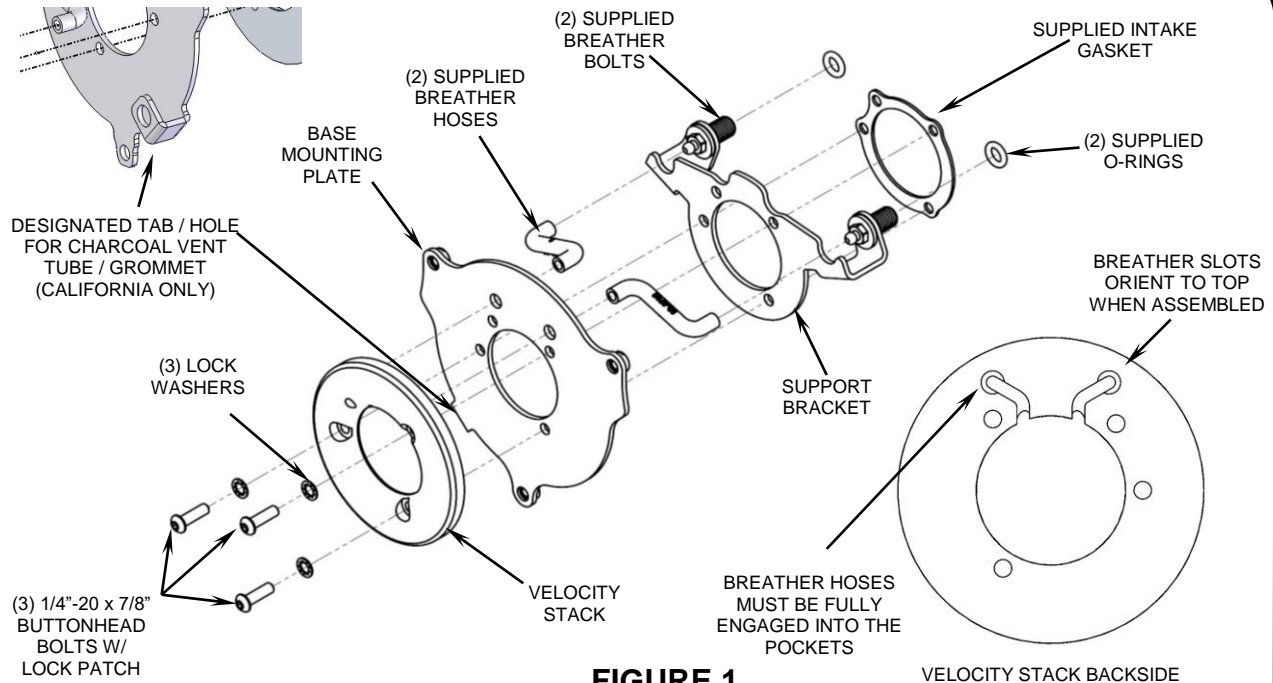

FIGURE 1

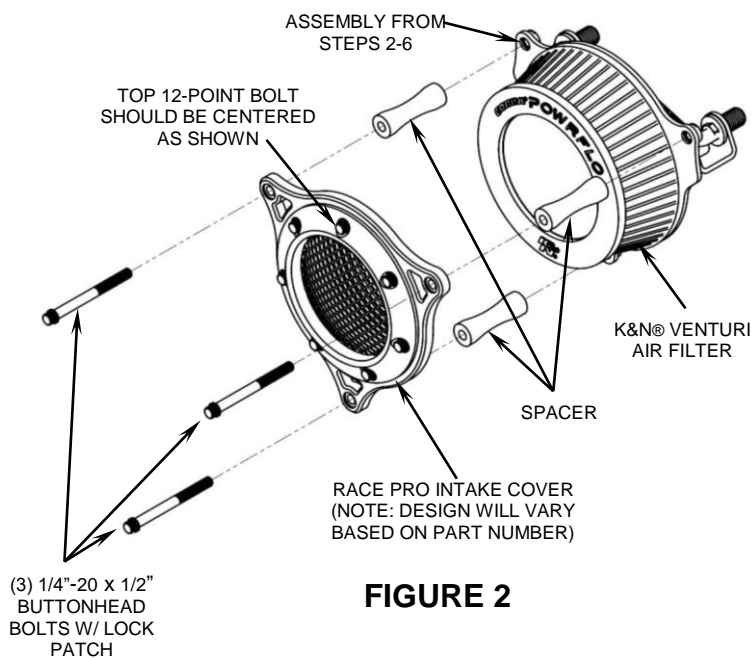

FIGURE 2

**CLEANING INSTRUCTIONS:**

To clean black portions of the RACE PRO air intake system use a liquid based soap detergent, such as dishwashing soap applied with a soft cloth and rinse with clean water. Note: Avoid abrasive cleaning methods such as granular or dry cleansers, simple green, Scotch-Brite or steel wool pads. Abrasives may breach the coating and shorten life.

**CALIFORNIA CUSTOMERS:**

In California, aftermarket parts that have been identified specifically as replacement parts or that have received an Air Resources Board Executive Order may be used on street motorcycles.

All other emissions related aftermarket parts are for competition use only. A list of replacement parts and EO parts, and corresponding fitment is provided at: [www.cobrausa.com](http://www.cobrausa.com)