

Items Supplied >

- 1 - INTAKE COVER W/ SCREEN / RING ASSEMBLY
- 1 - K&N® VENTURI AIR FILTER
- 1 - BASE MOUNTING PLATE
- 1 - BILLET VELOCITY STACK
- 1 - SUPPORT BRACKET
- 1 - INTAKE GASKET
- 2 - O-RING, SILICONE
- 2 - BREATHER BOLT, 3/8"-16 X 1"
- 3 - BOLT, 1/4"-20 X 7/8", BUTTONHEAD W/ LOCK PATCH
- 3 - BOLT, 1/4"-20 X 1/2", BUTTONHEAD W/ LOCK PATCH
- 3 - LOCK WASHER, 1/4" INTERNAL TOOTHED
- 1 - ZIPTIE, 4" #18 TEST

Application(s) >

HARLEY:	
SOFTAIL	2000-13
ROCKER	2008-11
DYNA	2000-13
DYNA SWITCHBACK	2012-13
DRESSER	1995-07

Instruction Manual >

606-0102 - 01 / 02 / 03 / 04

Page 1 of 2

Read all instructions carefully and completely before installing your new POWRFLO™ Intake.

1. Remove the allen bolt from the center of the stock air cleaner to remove the cover. Remove the (3) bolts securing the air filter. Then remove and discard the air filter, air box and seals/gaskets.
NOTE: For 2012 Dyna models, disengage the wire connector and cap from the backside of the air box.
2. Remove and discard the (2) stock breather bolts and (2) stock o-rings from the cylinder heads; save the breather hoses for reuse during installation.
3. Insert (3) supplied 1/4"-20 x 7/8" buttonhead bolts with lock washers through the mounting holes in the velocity stack and base mounting plate. While holding that assembly together with one hand, insert the (2) breather hoses through the mounting plate and into the velocity stack with the hoses rotated outward, as shown in Figure 1. Make sure the hoses are bottomed out in the back of the velocity stack.
4. Join together the assembly from Step 3 with the supplied support bracket and gasket then start threading the (3) buttonhead bolts into the throttle body, but do not tighten.

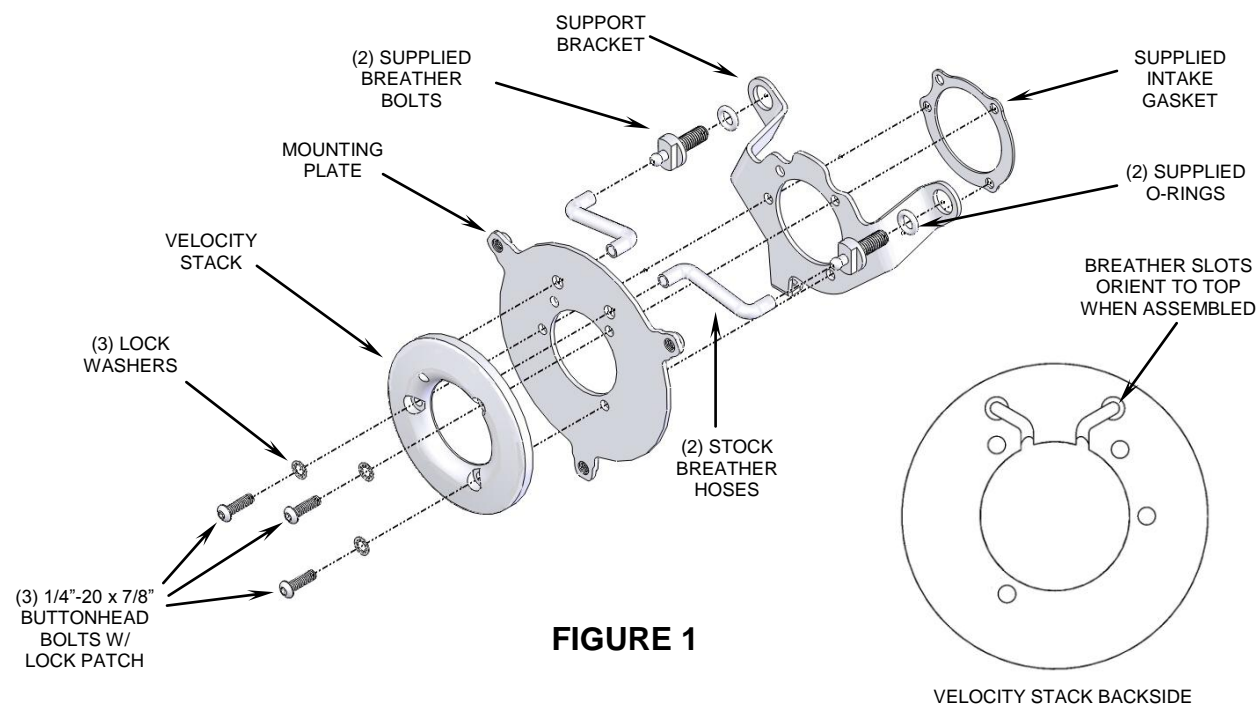

* Cobra® recommends you always wear a helmet while riding. Please never operate your motorcycle while under the influence of alcohol and/or drugs. Enjoy the new look of your motorcycle and please ride safely.

5. Place a supplied o-ring onto both supplied breather bolts. Insert the breather bolts through the support bracket openings and into the cylinder heads and lightly snug. Now snug the (3) buttonhead bolts evenly, and then fully tighten them to the throttle body. Tighten the (2) breather bolts.
6. Insert outer end of rubber hoses over nipples on breather bolts.
7. **For 2012 Dyna models** use the supplied ziptie to secure the wire connector/cap to the support bracket tab. See Figure 2. **NOTE: Secure ziptie around the connector, DO NOT ziptie around wires.**
8. Place the supplied K&N® filter onto the velocity stack. Insert the round intake screen into the chrome ring so the screen sits inside the edge of the ring. Place the ring and screen between the legs of the naked chrome intake cover as shown in Figure 3.
9. Place the naked intake cover, ring and screen assembled in Step 8, over the air filter and align each leg to the base mounting plate threaded holes. Be sure screen sits at a 45° angle to the bottom leg, and C/V logo'd leg is at the upper left position. Insert the (3) supplied 1/4"-20 x 1/2" buttonhead bolts through the intake cover and into the base mounting plate, see Figure 3. Double check all parts are aligned properly and tighten securely.

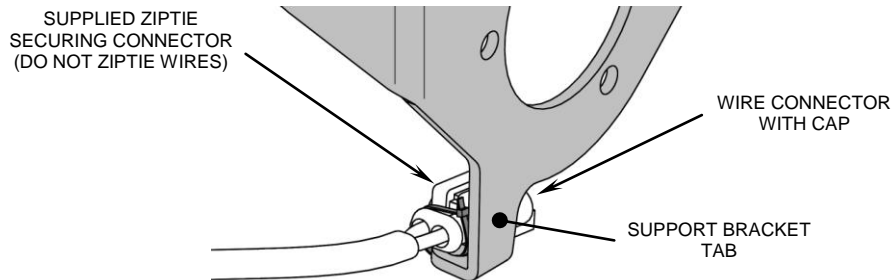

FIGURE 2

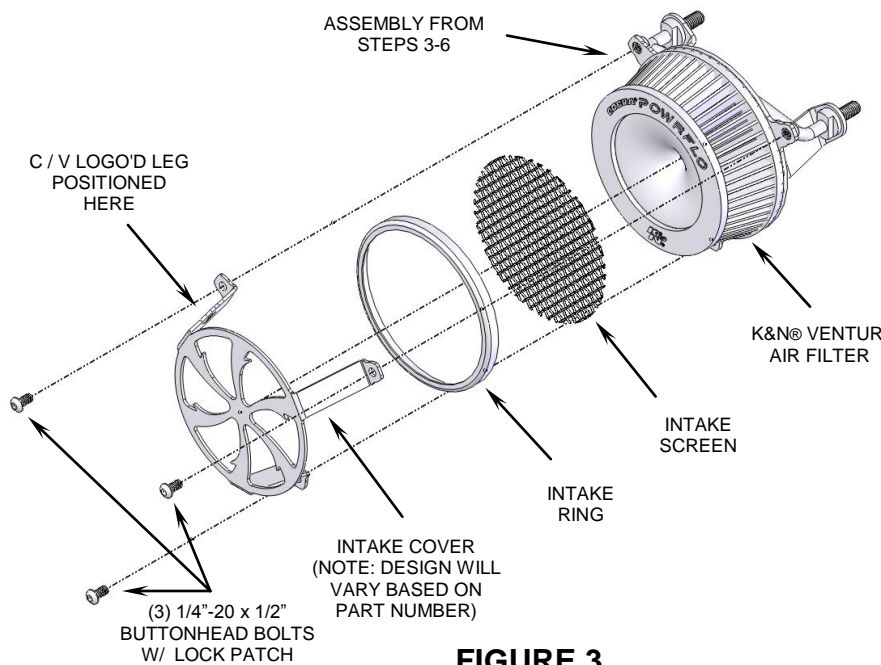

FIGURE 3

CALIFORNIA CUSTOMERS:

In California, aftermarket parts that have been identified specifically as replacement parts or that have received an Air Resources Board Executive Order may be used on street motorcycles.

All other emissions related aftermarket parts are for competition use only. A list of replacement parts and EO parts, and corresponding fitment is provided at: www.cobrausa.com

IMPORTANT: To achieve optimum performance from your new POWRFLO™ Air Intake it is suggested that you install a Cobra Fi2000® Digital Fuel Processor. Visit www.fi2000r.com