



Harley-Davidson, Inc.

# PARTS CATALOG

## 1984 FXST; 1985 to 1986 FX Models

Part No. 99455-86A

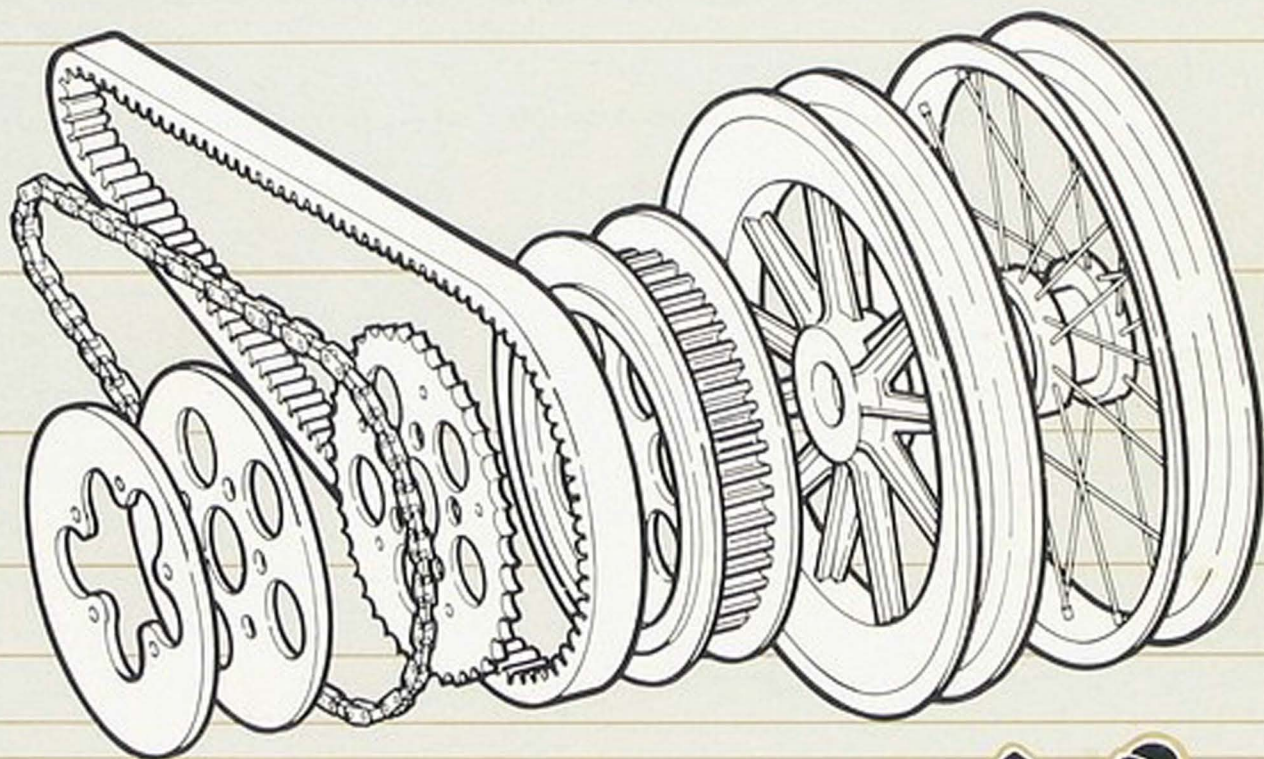





# ALPHABETICAL INDEX

	Page		Page
Air Cleaner .....	17	Ignition Module .....	21
Alternator .....	19	Ignition Switch — FXWG, FXST ..	131
Axle — Front .....	63, 65	Ignition Switch — FXSB, FXEF ...	133
Axle — Rear .....	67, 69	Indicator Lamps .....	112, 125, 127
Battery — FXWG, FXSB, FXEF ..	109	Instrument Panel — FXWG, FXST	125, 127
Battery — FXST .....	103	Instrument Panel — FXSB, FXEF .	129
Belt Guard — Rear—FXWG, FXSB	95	Jiffy Stand .....	83
Belt Guard — Rear-FXST .....	93	Kick Starter —	
Brake — Front .....	55	FXWG, FXSB, FSXT .....	29
Brake — Rear .....	61	License Plate Bracket .....	97
Brake Control — Front .....	53	Master Cylinder — Front .....	53
Brake Control —		Master Cylinder — Rear .....	57, 59
Rear-FXWG, FXST .....	57	Mirror .....	117
Brake Control —		Mufflers .....	107
Rear-FXSB, FXEF .....	59	Neutral Switch .....	135
Cam Gears .....	11	Numerical Index .....	144
Carburetor .....	15	Oil Filter — FXST .....	103
Cast Wheel — Front .....	65	Oil Filter — FXWG, FXSB, FXEF .	105
Cast Wheel — Rear .....	69	Oil Pump .....	13
Chains, Belts & Sprockets .....	51	Oil Tank — FXST .....	103
Chain Guard — Rear-FXEF, FXST	93,95	Oil Tank — FXWG, FXSB, FXEF .	105
Choke .....	17	Pistons .....	3, 7
Circuit Breaker .....	130	Primary Housing .....	99
Clutch .....	45, 47	Push Rods .....	5
Clutch Hand Control .....	49	Rims .....	63, 67
Connecting Rods .....	7	Rocker Arms .....	5
Crankcase .....	8, 9, 10, 11	Rotor .....	19
Cylinders .....	3	Seat .....	84
Electrical .....	121	Shifter .....	31, 33, 35
Electronic Ignition .....	21	Shock Absorber — FXST .....	88
Engine .....	3	Shock Absorber —	
Evaporative Emmissions Kit .....	136	FXWG, FXSB, FXEF .....	89
Exhaust Pipes .....	107	Solenoid, starter .....	135
Fenders — FXST .....	93	Spark Cables, Coil & Plugs .....	21
Fenders — FXWG, FXSB, FXEF .	95	Speedometer — FXWG, FXST ...	125, 127
FLST Model .....	139 — 143	Speedometer — FXSB, FXEF ...	129
Flywheels .....	7	Sprockets — Belt .....	39, 41, 51, 67, 69
Footrest — FXWG, FXST .....	85	Sprockets — Chain .....	39, 45, 47, 51, 67, 69
Footrest — FXSB, FXEF .....	86	Starter Housing — Belt .....	25
Footrest — Highway-FXSB .....	87	Starter Housing — Chain .....	23
Footshift .....	35	Starter Motor .....	27
Fork — Front-FXWG, FXST .....	71	Switches .....	123, 130, 131, 133, 135
Fork — Front-FXSB .....	73	Tachometer — FXSB, FXEF .....	129
Fork — Front-FXEF .....	75	Tail Lamp .....	113
Fork — Rear-FXST .....	79, 81	Tappets .....	5
Fork — Rear-FXWG, FXSB, FXEF	77	Throttle Control .....	91
Frame — FXST .....	79, 81	Transmission Gears — 5 Speed ..	43
Frame — FXWG, FXSB, FXEF ...	77	Transmission Housing — 5 Speed	41
Fuel Tanks .....	101	Transmission — Mainshaft &	
FXST Custom .....	137,138	Housing — 4 Speed .....	37
Gaskets .....	3, 5, 11, 13, 37, 97	Transmission — Countershaft	
Gear Case Cover .....	11	— 4 Speed .....	39
Gear Shifter — 4 Speed .....	31	Turn Signals .....	115
Gear Shifter — 5 Speed .....	33	Valves .....	3
Handlebar .....	90	Voltage Regulator .....	19
Headlamp — FXWG, FXST .....	111	Wheels — Cast .....	65, 69
Headlamp — FXSB, FXEF .....	112	Wheels — Spoke .....	63, 67
Horn .....	117	Wiring .....	119, 121

## PATENT NOTICE

Harley-Davidson products are manufactured under one or more of the following patents: U.S. Patents - 2986162, 2987934, 2998809, 3116089, 3144631, 3144860, 3226994, 3229792, 3434887, 3559773, 3673359, 3709317, Des. 225,626.

To the best knowledge of Harley-Davidson Motor Company, the material contained herein is accurate as of the date this publication was approved for printing. Harley-Davidson Motor Company reserves the right to change specifications, equipment, or designs at any time without notice and without incurring obligation.

HARLEY-DAVIDSON MOTOR COMPANY  
Milwaukee, WI 53201

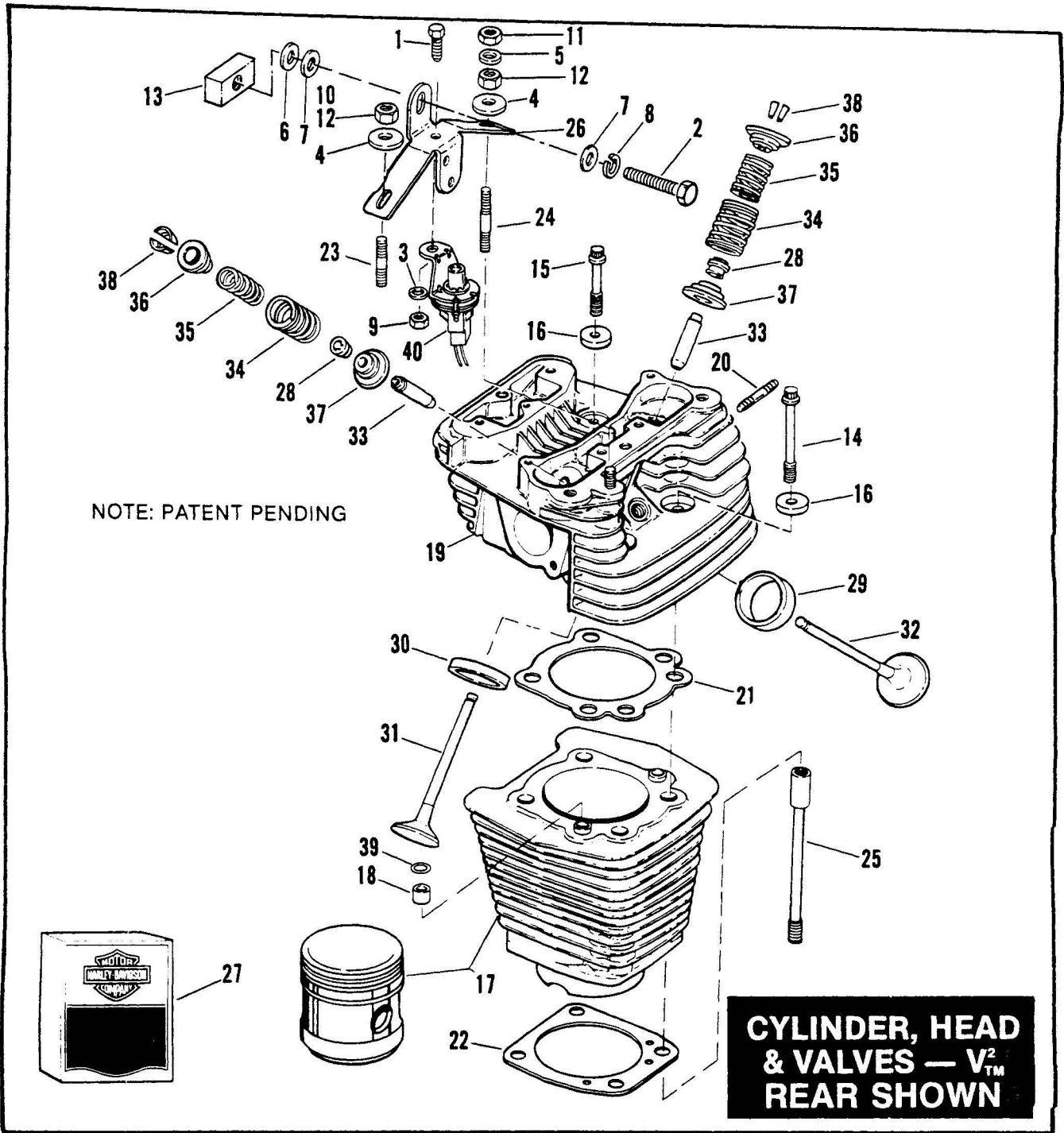

RETAIL PRICE	INDEX NO.	PART NO.	NAME	USED ON
	1	3987	BOLT	84 — FXST; 85 to * — All Models
	2	4726	BOLT	84 — FXST; 85 to * — All Models
	3	6016	WASHER	84 — FXST; 85 to * — All Models
	4	6019	WASHER (2)	84 — FXST; 85 to * — All Models
	5	6379W	WASHER	84 — FXST; 85 — All Models
	6	6497HW	WASHER (as req'd)	84 — FXST; 85 to * — All Models
	7	6516HW	WASHER (as req'd)	84 — FXST; 85 to * — All Models
	8	7039	LOCKWASHER	84 — FXST; 85 to * — All Models
	9	7739	LOCKNUT	84 — FXST; 85 to * — All Models
	10	7775	LOCKNUT	Early 84 — FXST; 85 — FXEF
	11	7776W	LOCKNUT	84 — FXST; 85 to * — All Models
	12	7800W	NUT (2 — Late 84 & Later)	84 — FXST; 85 to * — FXWG, FXSB
	13	16284—84	MOUNTING BLOCK	84 — FXST; 85 to * — All Models
	14	16478—83	SCREW (4)	84 — FXST; Early 85 — All Models
		16478—85A	SCREW, internal thread (4)	Late 85 to * — All Models
	15	16480—83	SCREW (4)	84 — FXST; Early 85 — All Models
		16480—85A	SCREW, internal thread (4)	Late 85 to * — All Models
	16	16482—83	WASHER (8)	84 — FXST; Early 85 — All Models
		16482—85	WASHER (8)	Late 85 to * — All Models
	17	16510—83	CYLINDER WITH PISTON (2)	84 — FXST; 85 to * — All Models
	18	16573—83	INSERT, cylinder stud (4)	84 — FXST; 85 to * — All Models
	19	16690—85B	HEAD, rear cylinder — includes valve guides & seats	84 to * — FXST; 86 to * — FXWG
		16691—85B	HEAD, front cylinder — includes valve guides & seats	84 to * — FXST; 86 to * — FXWG
	20	16715—83	STUD, rocker cover (4)	84 — FXST; 85 to * — All Models
	21	16773—85	GASKET, cylinder head (2)	84 — FXST; 85 to * — All Models
	22	16774—86A	GASKET, cylinder base (2)	84 — FXST; 85 to * — All Models
	23	16830—29A	STUD, engine mounting bracket (short)	84 — FXST; 85 to * — All Models
	24	16831—83	STUD, engine mounting bracket (long)	84 — FXST; 85 to * — All Models
	25	16837—83	STUD, cylinder base, external thread (8)	84 — FXST; Early 85 — All Models
		16837—85A	STUD, cylinder base, internal thread (8)	Late 85 to * — All Models
	26	16852—83A	BRACKET, engine mounting	84 — FXST; 85 to * — All Models
	27	17033—83A	GASKET KIT, top overhaul	84 — FXST; 85 to * — All Models
		17035—83B	GASKET KIT, engine overhaul	84 — FXST; 85 to * — All Models
	28	18001—83A	SEAL, valve (4)	84 — FXST; 85 to * — All Models
	29	18010—83	INSERT, exhaust valve seat (2)	84 — FXST; 85 to * — All Models
	30	18020—83	INSERT, intake valve seat (2)	84 — FXST; 85 to * — All Models
	31	18074—83	INTAKE VALVE (2)	84 — FXST; 85 to * — All Models
		18076—83	INTAKE VALVE, 0.03 short (2)	84 — FXST; 85 to * — All Models
	32	18082—83	EXHAUST VALVE (2)	84 — FXST; 85 to * — All Models
		18087—83	EXHAUST VALVE, 0.03 short (2)	84 — FXST; 85 to * — All Models
	33	18130—83C	VALVE GUIDE, int. & exh. — 0.001 O.S. (4)	84 — FXST; 85 to * — All Models
		18131—83C	VALVE GUIDE, int. & exh. — 0.003 O.S. (4)	84 — FXST; 85 to * — All Models
		18133—83A	VALVE GUIDE, int. & exh. — 0.002 O.S. (4)	84 — FXST; 85 to * — All Models
	34	18201—83	VALVE SPRING, outer (4)	84 — FXST; 85 to * — All Models
	35	18202—83	VALVE SPRING, inner (4)	84 — FXST; 85 to * — All Models
	36	18219—83	COLLAR, valve spring — upper (4)	84 — FXST; 85 to * — All Models
	37	18222—83	COLLAR, valve spring — lower (4)	84 — FXST; 85 to * — All Models
	38	18229—83	RETAINER, valve collar (8)	84 — FXST; 85 to * — All Models
	39	26432—76A	O-RING, cylinder stud insert (4)	84 — FXST; 85 to * — All Models
	40	26558—84	VACUUM SWITCH, carburetor	84 — FXST; 85 to * — All Models

NOTE: PATENT PENDING

# ROCKER ARMS, COVER & PUSHROD — V<sup>2</sup>™

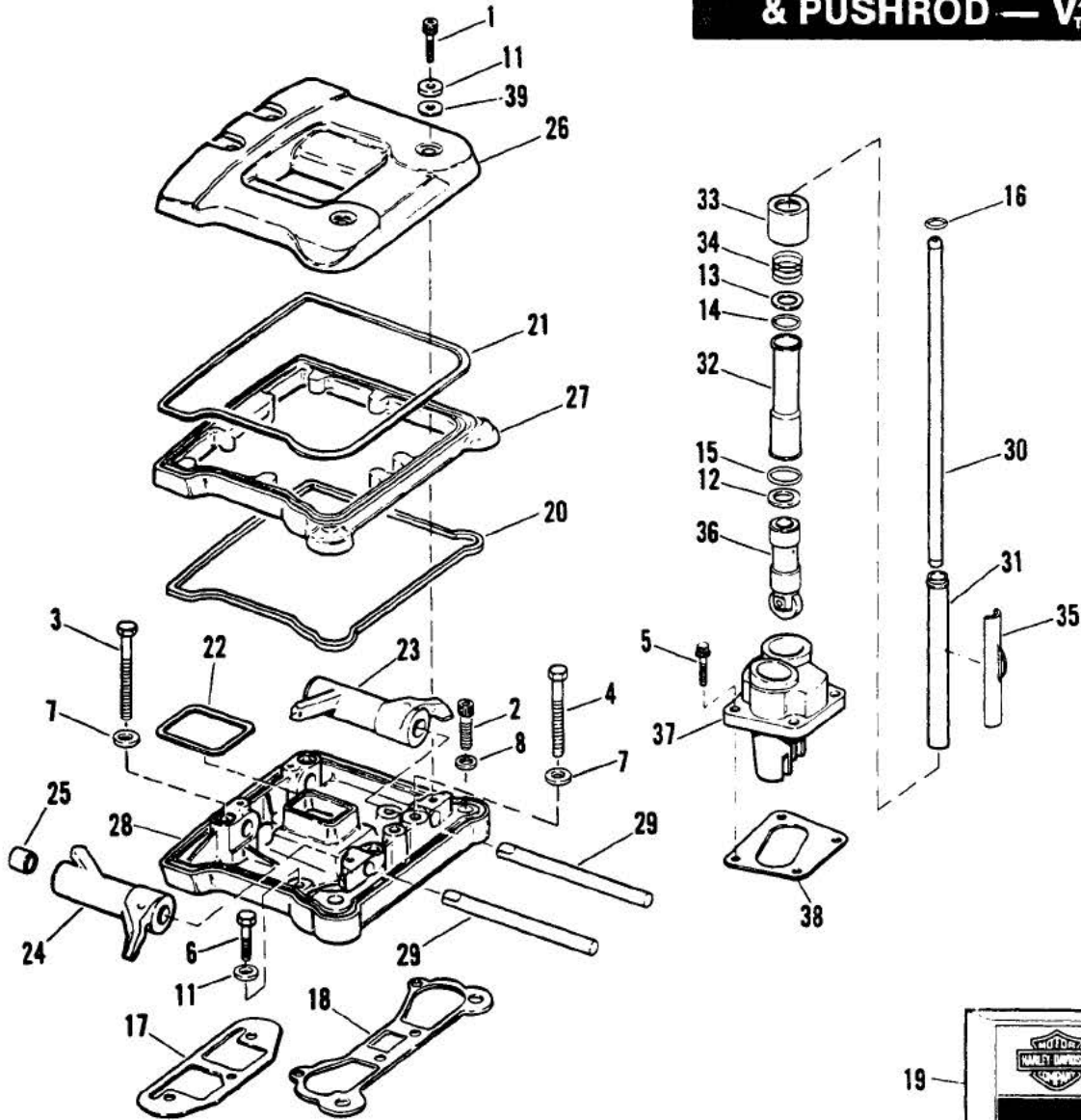

NOTE: PATENT PENDING

RETAIL PRICE	INDEX NO.	PART NO.	NAME	USED ON
	1	884	SCREW (8)	84 — FXST; 85 to * — All Models
	2	3481	SCREW (4)	84 — FXST; 85 to * — All Models
	3	3500	BOLT (4)	84 — FXST; 85 to * — All Models
	4	3501	BOLT (4)	84 — FXST; 85 to * — All Models
	5	3770	SCREW (8)	84 — FXST; 85 to * — All Models
	6	3997	BOLT (6)	84 — FXST; 85 to * — All Models
	7	6016	WASHER (8)	84 — FXST; 85 to * — All Models
	8	6099	WASHER (4)	84 — FXST; 85 to * — All Models
	11	6736	WASHER (14)	84 — FXST; 85 to * — All Models
	12	6737	WASHER (4)	84 — FXST; 85 to * — All Models
	13	6762B	WASHER (4)	84 — FXST; 85 to * — All Models
	14	11132	O-RING, push rod cover — middle (4)	84 — FXST; 85 to * — All Models
	15	11145	QUAD SEAL, push rod cover — lower (4)	84 — FXST; 85 to * — All Models
	16	11157	O-RING, push rod cover — upper (4)	84 — FXST; 85 to * — All Models
	17	16778—84	GASKET, cylinder head — right (2)	N/A 84 — FXST; 85 to * — All Models
	18	16779—84A	GASKET, cylinder head (2)	84 — FXST; 85 to * — All Models
	19	17033—83A	GASKET KIT, top overhaul	84 — FXST; 85 to * — All Models
		17035—83B	GASKET KIT, engine overhaul	84 — FXST; 85 to * — All Models
	20	17355—84A	GASKET, rocker cover — lower (2)	84 — FXST; 85 to * — All Models
	21	17356—84A	GASKET, rocker cover — upper (2)	84 — FXST; 85 to * — All Models
	22	17358—84A	GASKET, rocker cover — inner (2)	84 — FXST; 85 to * — All Models
	23	17360—83	ROCKER ARM, front intake, rear exhaust (2)	84 — FXST; 85 to * — All Models
	24	17375—83	ROCKER ARM, rear intake, front exhaust (2)	84 — FXST; 85 to * — All Models
	25	17428—57	BUSHING, rocker arm (8)	84 — FXST; 85 to * — All Models
	26	17503—84A	ROCKER COVER, outer (2)	84 — FXST; 85 to * — All Models
	27	17510—84	SPACER, rocker covers (2)	84 — FXST; 85 to * — All Models
	28	17521—84B	ROCKER COVER, inner (2)	84 — FXST; 85 to * — All Models
	29	17611—83	SHAFT, rocker arm (4)	84 — FXST; 85 to * — All Models
	30	17921—83	PUSH ROD, rear exhaust — 11.210"	84 — FXST; 85 to * — All Models
		17922—83	PUSH ROD, rear exhaust — 11.240"	N/A 84 — FXST; 85 to * — All Models
		17923—83	PUSH ROD, rear exhaust — 11.270"	N/A 84 — FXST; 85 to * — All Models
		17924—83	PUSH ROD, rear intake — 11.045"	84 — FXST; 85 to * — All Models
		17925—83	PUSH ROD, rear intake — 11.075"	N/A 84 — FXST; 85 to * — All Models
		17926—83	PUSH ROD, rear intake — 11.105"	N/A 84 — FXST; 85 to * — All Models
		17927—83	PUSH ROD, front exhaust — 11.325"	84 — FXST; 85 to * — All Models
		17928—83	PUSH ROD, front exhaust — 11.355"	N/A 84 — FXST; 85 to * — All Models
		17929—83	PUSH ROD, front exhaust — 11.385"	N/A 84 — FXST; 85 to * — All Models
		17930—83	PUSH ROD, front intake — 11.090"	84 — FXST; 85 to * — All Models
		17931—83	PUSH ROD, front intake — 11.120"	N/A 84 — FXST; 85 to * — All Models
		17932—83	PUSH ROD, front intake — 11.150"	N/A 84 — FXST; 85 to * — All Models
	31	17935—79B	COVER, push rod — upper (4)	84 — FXST; 85 to * — All Models
	32	17938—83	COVER, push rod — lower (4)	84 — FXST; 85 to * — All Models
	33	17945—36B	CAP, cover spring (4)	84 — FXST; 85 to * — All Models
	34	17947—36	SPRING, push rod cover (4)	84 — FXST; 85 to * — All Models
	35	17950—66	RETAINER, spring cap (4)	84 — FXST; 85 to * — All Models
	36	18523—86	TAPPET, with roller (4)	84 — FXSR; 85 to * — All Models
	37	18540—83A	TAPPET GUIDE, rear	84 — FXST; 85 to * — All Models
		18542—83A	TAPPET GUIDE, front	84 — FXST; 85 to * — All Models
	38	18633—48C	GASKET, tappet guide — rear	84 — FXST; 85 to * — All Models
		18634—48B	GASKET, tappet guide — front	84 — FXST; 85 to * — All Models
	39	63858—49	GASKET (8)	84 — FXST; 85 to * — All Models

NOTE: PATENT PENDING





# PISTONS, CONNECTING RODS & FLYWHEELS

FX3

RETAIL PRICE	INDEX NO.	PART NO.	NAME	USED ON
	1	6506	WASHER, flywheel — bronze (2)	84 — FXST; 85 to * — All Models
	2	9181	ROLLER, crank pin — 0.0004 O.S. (17)	N/A 84 — FXST; 85 to * — All Models
		9182	ROLLER, crank pin — 0.0006 O.S. (17)	84 — FXST; 85 to * — All Models
		9183	ROLLER, crank pin — 0.0008 O.S. (17)	84 — FXST; 85 to * — All Models
		9184	ROLLER, crank pin — 0.0010 O.S. (17)	N/A 84 — FXST; 85 to * — All Models
		9185	ROLLER, crank pin — 0.0002 U.S. (17)	84 — FXST; 85 to * — All Models
		9186	ROLLER, crank pin — standard (17)	N/A 84 — FXST; 85 to * — All Models
	3	9441A	ROLLER, crank pin — standard (34)	84 — FXST; 85 to * — All Models
		9443A	ROLLER, crank pin — 0.0004 O.S. (34)	84 — FXST; 85 to * — All Models
		9444A	ROLLER, crank pin — 0.0006 O.S. (34)	84 — FXST; 85 to * — All Models
		9445A	ROLLER, crank pin — 0.0008 O.S. (34)	84 — FXST; 85 to * — All Models
		9446A	ROLLER, crank pin — 0.0010 O.S. (34)	N/A 84 — FXST; 85 to * — All Models
		9450A	ROLLER, crank pin — 0.0002 U.S. (34)	84 — FXST; 85 to * — All Models
	4	11218	KEY (2)	84 — FXST; 85 to * — All Models
	5	21920—83	PISTON RING SET — standard (2)	84 — FXST; 85 to * — All Models
		21921—83	PISTON RING SET — 0.005 O.S. (2)	84 — FXST; 85 to * — All Models
		21922—83	PISTON RING SET — 0.01 O.S. (2)	84 — FXST; 85 to * — All Models
		21923—83	PISTON RING SET — 0.02 O.S. (2)	84 — FXST; 85 to * — All Models
		21924—83	PISTON RING SET — 0.03 O.S. (2)	84 — FXST; 85 to * — All Models
	6	21940—83	PISTON AND RINGS ASSEMBLY — standard (2)	84 — FXST; 85 to * — All Models
		21941—83	PISTON AND RINGS ASSEMBLY — 0.005 O.S. (2)	84 — FXST; 85 to * — All Models
		21942—83	PISTON AND RINGS ASSEMBLY — 0.01 O.S. (2)	84 — FXST; 85 to * — All Models
		21943—83	PISTON AND RINGS ASSEMBLY — 0.02 O.S. (2)	84 — FXST; 85 to * — All Models
		21944—83	PISTON AND RINGS ASSEMBLY — 0.03 O.S. (2)	84 — FXST; 85 to * — All Models
	7	22589—83	LOCK RING, piston ring (4)	84 — FXST; 85 to * — All Models
	8	22764—83	PISTON PIN — standard (2)	84 — FXST; 85 to * — All Models
	9	23906—78G	SET OF FLYWHEELS AND SHAFTS WITH RODS	84 — FXST; 85 to * — All Models
	10	23909—80	SPROCKET SHAFT	84 — FXST; Early 85 — All Models
	11	23961—80A	CRANK PIN	84 — FXST; 85 to * — All Models
		23974—87	CRANK PIN — 0.001 O.S.	84 — FXST; 85 to * — All Models
		23975—87	CRANK PIN — 0.002 O.S.	84 — FXST; 85 to * — All Models
	12	23969—83	NUT, crank pin (2)	84 — FXST; 85 to * — All Models
	13	23985—54	KEY, gear shaft pinion	84 — FXST; 85 to * — All Models
	14	24006—83	GEAR SHAFT	84 — FXST; 85 to * — All Models
	15	24016—80	NUT, gear shaft	84 — FXST; 85 to * — All Models
	16	24017—80	NUT, sprocket shaft	84 — FXST; Early 85 — All Models
	17	24281—83	SET OF CONNECTING RODS WITH BRGS. AND CRANK PIN	84 — FXST; 85 to * — All Models
	18	24334—36	BUSHING, piston pin — 0.002 O.S. (2)	84 — FXST; 85 to * — All Models
		24335—36	BUSHING, piston pin — 0.01 O.S. (2)	84 — FXST; 85 to * — All Models
	19	24345—36A	BUSHING, rear connecting rod — lower (2)	84 — FXST; 85 to * — All Models
	19A	24346—87	BEARING SET	84 — FXST; 85 to * — All Models
	20	24356—36A	BUSHING, front connecting rod — lower	84 — FXST; 85 to * — All Models
	21	24366—71	RETAINER, crank pin roller — rear rod (2)	N/A 84 — FXST; 85 to * — All Models
	22	24367—71	RETAINER, crank pin roller — front rod	N/A 84 — FXST; 85 to * — All Models
	23	24385—40B	SET OF ROLLERS AND RETAINERS — standard	N/A 84 — FXST; 85 to * — All Models
		24387—40B	SET OF ROLLERS AND RETAINERS — 0.0004 O.S.	N/A 84 — FXST; 85 to * — All Models
		24388—40B	SET OF ROLLERS AND RETAINERS — 0.0006 O.S.	N/A 84 — FXST; 85 to * — All Models
		24389—40B	SET OF ROLLERS AND RETAINERS — 0.0008 O.S.	N/A 84 — FXST; 85 to * — All Models
		24390—40B	SET OF ROLLERS AND RETAINERS — 0.0010 O.S.	N/A 84 — FXST; 85 to * — All Models
		24391—40B	SET OF ROLLERS AND RETAINERS — 0.0002 U.S.	N/A 84 — FXST; 85 to * — All Models
	24	26348—15	KEY, gear shaft pinion	84 — FXST; 85 to * — All Models

# CRANKCASE

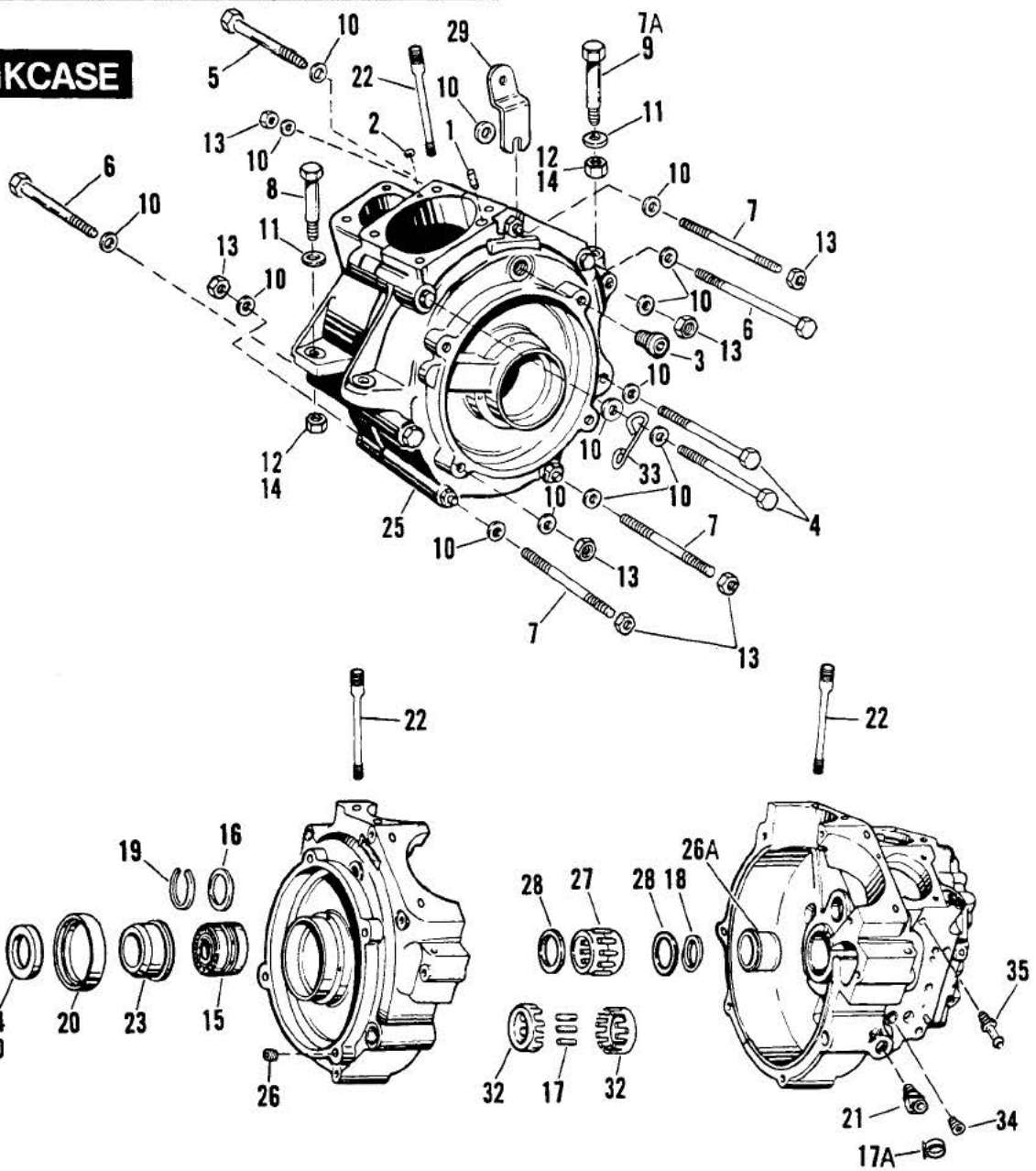

## CRANKCASE

FX4-1

RETAIL PRICE	INDEX NO.	PART NO.	NAME	USED ON
	1	358	DOWEL PIN (2)	84 - FXST; 85 to * - All Models
	2	653	EXPANSION PLUG	84 - FXST; 85 to * - All Models
	3	720	PLUG, timing hole	84 - FXST; 85 to * - All Models
	4	3427	BOLT (2)	84 - FXST; 85 to * - All Models
	5	3430	BOLT	84 - FXST; 85 to * - All Models
	6	3504	BOLT (2)	84 - FXST; 85 to * - All Models
	7	3506	STUD (3)	84 - FXST; 85 to * - All Models
	7A	3512	BOLT (2)	86 to * - All Models
	8	4401W	BOLT (2)	84 - FXST; 85 - All Models
		4416	BOLT (2)	86 to * - All Models
	9	4435W	BOLT (2)	84 - FXST; 85 - All Models
	10	6016	WASHER (16)	84 - FXST; 85 to * - All Models
	11	6400HB	WASHER (4)	84 - FXST; 85 to * - All Models

RETAIL PRICE	INDEX NO.	PART NO.	NAME	USED ON
	12	7506	LOCKNUT (4; 2 — Late 85)	Late 85 to * — All Models
	13	7753	NUT (9)	84 — FXST; 85 to * — All Models
	14	7775	LOCKNUT (4; 2 — Late 85)	84 — FXST; 85 — All Models
	15	9028	BEARING ASSEMBLY, sprocket shaft (Timken)	84 — FXST; 85 to * — All Models
	16	9120	SHIM, bearing assembly, 0.0925-.0915	84 — FXST; 85 to * — All Models
		9121	SHIM, bearing assembly, 0.0945-.0935	84 — FXST; 85 to * — All Models
		9122	SHIM, bearing assembly, 0.0965-.0955	84 — FXST; 85 to * — All Models
		9123	SHIM, bearing assembly, 0.0985-.0975	84 — FXST; 85 to * — All Models
		9124	SHIM, bearing assembly, 0.1005-.0995	84 — FXST; 85 to * — All Models
		9125	SHIM, bearing assembly, 0.1025-.1015	84 — FXST; 85 to * — All Models
		9126	SHIM, bearing assembly, 0.1045-.1035	84 — FXST; 85 to * — All Models
		9127	SHIM, bearing assembly, 0.1065-.1055	84 — FXST; 85 to * — All Models
		9128	SHIM, bearing assembly, 0.1085-.1075	84 — FXST; 85 to * — All Models
		9129	SHIM, bearing assembly, 0.1105-.1095	84 — FXST; 85 to * — All Models
		9130	SHIM, bearing assembly, 0.1125-.1115	84 — FXST; 85 to * — All Models
		9131	SHIM, bearing assembly, 0.1145-.1135	84 — FXST; 85 to * — All Models
		9132	SHIM, bearing assembly, 0.1165-.1155	84 — FXST; 85 to * — All Models
		9133	SHIM, bearing assembly, 0.1185-.1175	84 — FXST; 85 to * — All Models
		9134	SHIM, bearing assembly, 0.1205-.1195	84 — FXST; 85 to * — All Models
	17	9217	ROLLER, right bearing — 0.0005 O.S. (28)	84 — FXST; 85 to * — All Models
		9218	ROLLER, right bearing — 0.0003 O.S. (28)	84 — FXST; 85 to * — All Models
		9219	ROLLER, right bearing — 0.0001 O.S. (28)	84 — FXST; 85 to * — All Models
		9221A	ROLLER, right bearing — 0.0002 O.S. (28)	84 — FXST; 85 to * — All Models
		9222A	ROLLER, right bearing — 0.0004 O.S. (28)	84 — FXST; 85 to * — All Models
		9223A	ROLLER, right bearing — 0.0006 O.S. (28)	84 — FXST; 85 to * — All Models
		9224A	ROLLER, right bearing — 0.0008 O.S.	84 — FXST; 85 to * — All Models
		9225A	ROLLER, right bearing — 0.0010 O.S.	84 — FXST; 85 to * — All Models
	17A	10080	CLAMP, crankcase fitting	84 — FXST; 85 to * — All Models
	18	11007	RETAINING RING, right bearing	84 — FXST; 85 to * — All Models
	19	11160	RETAINING RING, crankcase bearing	84 — FXST; 85 to * — All Models
	20	12026B	OIL SEAL	84 — FXST; 85 to * — All Models
	21	16302—81	FITTING, crankcase	84 — FXST; 85 to * — All Models
	22	16837—83	STUD, cylinder base (8)	84 — FXST; 85 to * — All Models
	23	24002—70	SPACER, sprocket shaft	84 — FXST; 85 to * — All Models
	24	24032—70	SPACER, sprocket shaft — 0.06 thick	84 — FXST; 85 to * — All Models
		24033—70	SPACER, sprocket shaft — 0.09 thick	84 — FXST; 85 to * — All Models
		24034—70	SPACER, sprocket shaft — 0.12 thick	84 — FXST; 85 to * — All Models
		24035—70	SPACER, sprocket shaft — 0.15 thick	84 — FXST; 85 to * — All Models
		24036—70	SPACER, sprocket shaft — 0.18 thick	84 — FXST; 85 to * — All Models
		24037—70	SPACER, sprocket shaft — 0.21 thick	84 — FXST; 85 to * — All Models
	25	24546—83C	CRANKCASE SET	84 — FXST; 85 to * — All Models
	26	24553—83	INSERT, left crankcase (4)	N/A
	26A	24599—58A	BUSHING, right crankcase — standard	84 — FXST; 85 to * — All Models
		24600—58A	BUSHING, right crankcase — 0.002 O.S. O.D.	84 — FXST; 85 to * — All Models
		24601—58A	BUSHING, right crankcase — 0.005 O.S. O.D.	84 — FXST; 85 to * — All Models
	27	24645—81	RIGHT BEARING — 0.0005 O.S.	84 — FXST; 85 to * — All Models
		24649—81	RIGHT BEARING — 0.0003 O.S.	84 — FXST; 85 to * — All Models
		24650—81	RIGHT BEARING — 0.0001 O.S.	84 — FXST; 85 to * — All Models
		24651—58	RIGHT BEARING — 0.0002 O.S.	84 — FXST; 85 to * — All Models
		24652—58	RIGHT BEARING — 0.0004 O.S.	84 — FXST; 85 to * — All Models
		24653—58	RIGHT BEARING — 0.0006 O.S.	84 — FXST; 85 to * — All Models
		24654—58	RIGHT BEARING — 0.0008 O.S.	84 — FXST; 85 to * — All Models
		24655—58	RIGHT BEARING — 0.0010 O.S.	N/A
	28	24692—58	WASHER, right bearing (2)	84 — FXST; 85 to * — All Models
	29	25405—82	BRACKET, clutch cable routing	84 — FXST; 85 to * — All Models
	30	35850—84	SPACER, sprocket shaft — 0.01 thick	84 — FXST; 85 to * — All Models
		35851—84	SPACER, sprocket shaft — 0.02 thick	84 — FXST; 85 to * — All Models
		35852—84	SPACER, sprocket shaft — 0.03 thick	84 — FXST; 85 to * — All Models
	32	43578—35	RETAINER, right roller bearing (2)	84 — FXST; 85 to * — All Models
	33	45095—85	WIRE RETAINER	86 to * — All Models
	34	45830—48	PLUG, crankcase oil line	Late 84 — FXST; 85 to * — All Models
	35	63533—41	FITTING, vent hose	84 — FXST; 85 to * — All Models

## CRANKCASE — GEAR SIDE

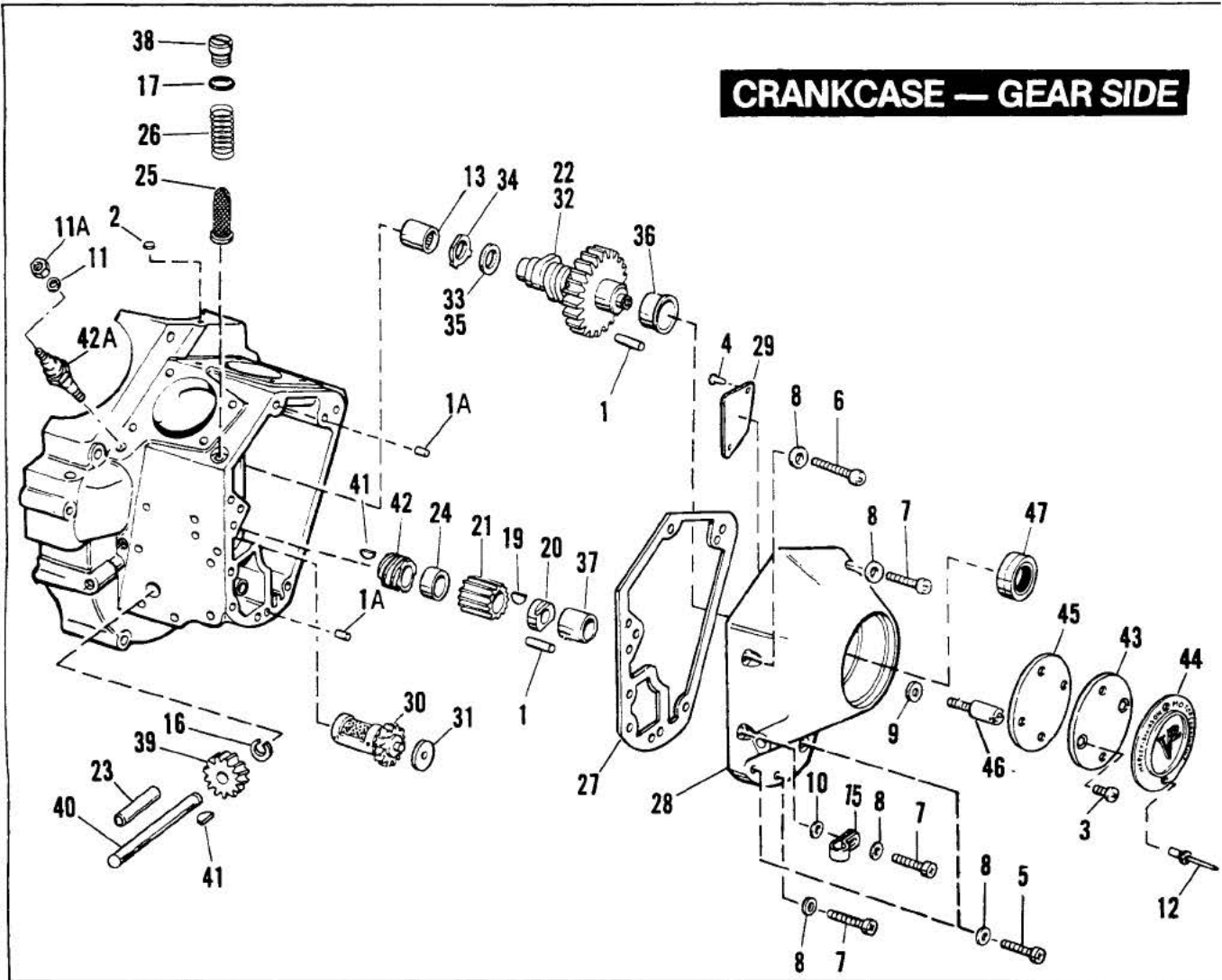

## CRANKCASE — GEAR SIDE

FX5-

RETAIL PRICE	INDEX NO.	PART NO.	NAME	USED ON
	1	275	DOWEL PIN (2 — as required)	84 — FXST; 85 to * — All Models
	1A	358	DOWEL PIN (2)	84 — FXST; 85 to * — All Models
	2	653	PLUG, crankcase	84 — FXST; 85 to * — All Models
	3	1601	SCREW (2)	84 — FXST; 85 to * — All Models
	4	2511	SCREW (2)	84 — FXST; 85 to * — All Models
	5	4740	SCREW (2)	84 — FXST; 85 to * — All Models
	6	4810	SCREW (w/lock patch)	84 — FXST; 85 to * — All Models
	7	4813	SCREW (w/nylon lock patch) (3)	84 — FXST; 85 to * — All Models
	8	6099	WASHER (6)	84 — FXST; 85 to * — All Models
	9	6194	WASHER (2)	84 — FXST; 85 — All Models
	10	6242W	WASHER	84 — FXST; 85 to * — All Models
	11	7069	LOCKWASHER	84 — FXST; 85 to * — All Models
	11A	7634	NUT	84 — FXST; 85 to * — All Models
	12	8699	POP RIVET (2)	84 — FXST; 85 to * — All Models
	13	9058	NEEDLE BEARING, crankcase cam gear	84 — FXST; 85 to * — All Models
	15	10046	CLAMP, electronic ignition wire	84 — FXST; 85 to * — All Models
	16	11002	RETAINING RING, oil pump drive shaft	84 — FXST; 85 to * — All Models
	17	11105	O-RING	84 — FXST; 85 to * — All Models

**CRANKCASE — GEAR SIDE (CONT'D)**

RETAIL PRICE	INDEX NO.	PART NO.	NAME	USED ON
	19	23985-54	KEY, gear shaft	84 — FXST; 85 to * — All Models
	20	24023-54	NUT, gear shaft	84 — FXST; 85 to * — All Models
	21	24040-78	PINION GEAR, 1.4751-56 pitch dia. (orange)	84 — FXST; 85 to * — All Models
		24041-78	PINION GEAR, 1.4745-51 pitch dia. (white)	84 — FXST; 85 to * — All Models
		24042-78	PINION GEAR, 1.4737-45 pitch dia. (yellow)	84 — FXST; 85 to * — All Models
		24043-78	PINION GEAR, 1.4729-37 pitch dia. (red)	84 — FXST; 85 to * — All Models
		24044-78	PINION GEAR, 1.4721-29 pitch dia. (blue)	84 — FXST; 85 to * — All Models
		24045-78	PINION GEAR, 1.4715-21 pitch dia. (green)	84 — FXST; 85 to * — All Models
		24046-78	PINION GEAR, 1.4710-15 pitch dia. (black)	84 — FXST; 85 to * — All Models
	22	24582-83A	CAM & PINION GEAR SET, matched	84 — FXST; 85 — All Models
	23	24641-36	BUSHING, oil pump shaft	84 — FXST; 85 to * — All Models
	24	24703-54B	SPACER, gear shaft pinion	84 — FXST; 85 to * — All Models
	25	24981-70	OIL SCREEN, crankcase	84 — FXST; 85 to * — All Models
	26	24982-70	OIL SCREEN SPRING	84 — FXST; 85 to * — All Models
	27	25225-70B	GASKET, gear cover	84 — FXST; 85 to * — All Models
	28	25258-80B	GEAR COVER, includes items 4 & 29	84 — FXST; 85 to * — All Models
	29	25275-82	COVER, breather valve	84 — FXST; 85 to * — All Models
	30	25313-77B	BREATHER VALVE, with gear (plastic)	84 — FXST; 85 to * — All Models
	31	25320-82	THRUST WASHER, breather valve — 0.130 thick (plastic)	84 — FXST; 85 to * — All Models
		25321-82	THRUST WASHER, breather valve — 0.135 thick (plastic)	84 — FXST; 85 to * — All Models
		25322-82	THRUST WASHER, breather valve — 0.140 thick (plastic)	84 — FXST; 85 to * — All Models
		25323-82	THRUST WASHER, breather valve — 0.145 thick (plastic)	84 — FXST; 85 to * — All Models
		25325-82	THRUST WASHER, breather valve — 0.150 thick (plastic)	84 — FXST; 85 to * — All Models
		25326-82	THRUST WASHER, breather valve — 0.155 thick (plastic)	84 — FXST; 85 to * — All Models
		25327-82	THRUST WASHER, breather valve — 0.160 thick (plastic)	84 — FXST; 85 to * — All Models
		25328-82	THRUST WASHER, breather valve — 0.165 thick (plastic)	84 — FXST; 85 to * — All Models
	32	25536-84	CAM GEAR (orange) N/A	84 — FXST; 85 to * — All Models
		25537-84	CAM GEAR (white) N/A	84 — FXST; 85 to * — All Models
		25538-84	CAM GEAR (yellow) N/A	84 — FXST; 85 to * — All Models
		25539-84	CAM GEAR (red) N/A	84 — FXST; 85 to * — All Models
		25544-84	CAM GEAR (blue) N/A	84 — FXST; 85 to * — All Models
		25545-84	CAM GEAR (green) N/A	84 — FXST; 85 to * — All Models
		25546-84	CAM GEAR (black) N/A	84 — FXST; 85 to * — All Models
	33	25550-36	THRUST WASHER, cam gear — 0.050 thick	84 — FXST; 85 to * — All Models
	34	25550-57	LOCKWASHER, cam gear	84 — FXST; 85 to * — All Models
	35	25551-36	THRUST WASHER, cam gear — 0.050 thick	84 — FXST; 85 to * — All Models
		25552-36	THRUST WASHER, cam gear — 0.060 thick	84 — FXST; 85 to * — All Models
		25553-36	THRUST WASHER, cam gear — 0.065 thick	84 — FXST; 85 to * — All Models
		25554-36	THRUST WASHER, cam gear — 0.070 thick	84 — FXST; 85 to * — All Models
		25555-36	THRUST WASHER, cam gear — 0.075 thick	84 — FXST; 85 to * — All Models
		25555-84	THRUST WASHER, cam gear — 0.045 thick	84 — FXST; 85 to * — All Models
		25556-79	THRUST WASHER, cam gear — 0.080 thick	84 — FXST; 85 to * — All Models
		25557-79	THRUST WASHER, cam gear — 0.085 thick	84 — FXST; 85 to * — All Models
		25558-79	THRUST WASHER, cam gear — 0.090 thick	84 — FXST; 85 to * — All Models
		25559-79	THRUST WASHER, cam gear — 0.095 thick	84 — FXST; 85 to * — All Models
	36	25581-70	BUSHING, gear cover	84 — FXST; 85 to * — All Models
	37	25582-73	BUSHING, gear cover pinion shaft	84 — FXST; 85 to * — All Models
	38	26263-80	PLUG, oil pump	84 — FXST; 85 to * — All Models
	39	26345-73	DRIVE GEAR, oil pump — 24 T	84 — FXST; 85 to * — All Models
	40	26346-70	DRIVE SHAFT, oil pump	84 — FXST; 85 to * — All Models
	41	26348-15	KEY, oil pump gear (2)	84 — FXST; 85 to * — All Models
	42	26349-73A	DRIVE GEAR, oil pump	84 — FXST; 85 to * — All Models
		26349-84	DRIVE GEAR, oil pump	Late 85 to * — All Models
	42A	26561-84	OIL PRESSURE SWITCH	84 — FXST; 85 to * — All Models
	43	32504-80	TIMER COVER	84 — FXST; 85 to * — All Models
	44	32524-83	TIMER COVER (polished aluminum)	84 — FXST; 85 to * — All Models
	45	32591-80	GASKET, ignition timer cover	84 — FXST; 85 to * — All Models
	46	32606-82	STUD, ignition timer cover (2)	84 — FXST; 85 to * — All Models
	47	83162-51	OIL SEAL	84 — FXST; 85 to * — All Models

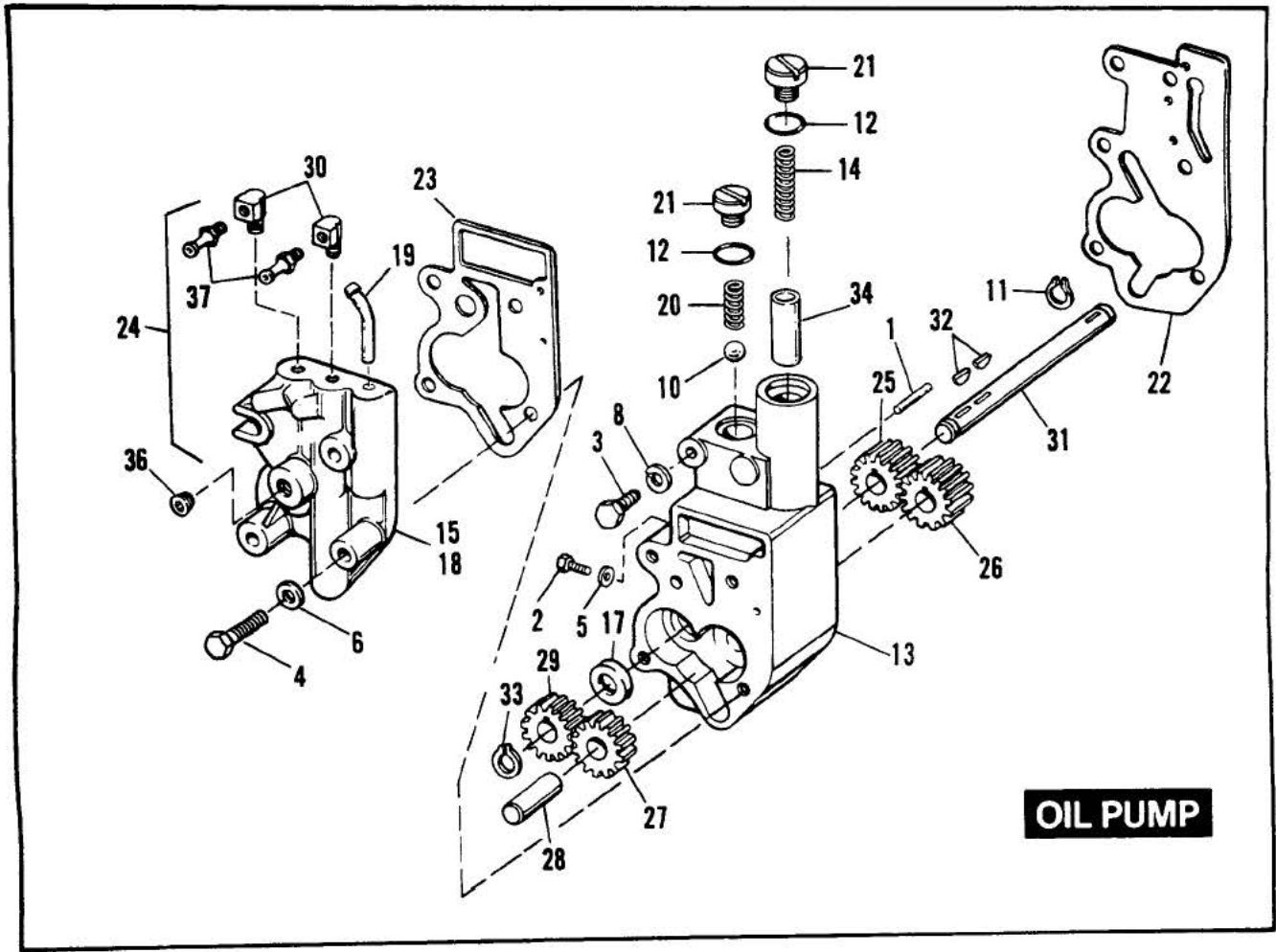

# OIL PUMP

FX6

RETAIL PRICE	INDEX NO.	PART NO.	NAME	USED ON
	1	239	PIN, valve stop	84 — FXST; 85 to * — All Models
	2	700	PLUG, oil pump body	84 — FXST; 85 to * — All Models
	3	2872W	BOLT (2)	84 — FXST; 85 to * — All Models
	4	3429	BOLT (4)	84 — FXST; 85 to * — All Models
	5	6377	WASHER	84 — FXST; 85 to * — All Models
	6	6736	WASHER (4)	84 — FXST; 85 to * — All Models
	8	7036	LOCKWASHER (2)	84 — FXST; 85 to * — All Models
	10	8873	BALL, check valve — 3/8 dia.	84 — FXST; 85 to * — All Models
	11	11002	RETAINING RING, oil pump	84 — FXST; 85 to * — All Models
	12	11105	O-RING, check valve cover screw (2)	84 — FXST; 85 to * — All Models
	13	26190—73	OIL PUMP KIT	84 — FXST; 85 to * — All Models
	14	26207—83	SPRING, relief valve	84 — FXST; 85 to * — All Models
	15	26216—84	COVER, oil pump	Early 84 — FXST
	17	26227—58	OIL SEAL	84 — FXST; 85 to * — All Models
	18	26242—84	COVER, oil pump	Late 84 — FXST; 85 to * — All Models
	19	26247—78	TUBE, cover — upper (bent)	Early 84 — FXST
	20	26262—80	SPRING, check valve	84 — FXST; 85 to * — All Models
	21	26263—80	COVER SCREW, check valve and relief valve (2)	84 — FXST; 85 to * — All Models
	22	26273—80B	GASKET, body (paper)	84 — FXST; 85 to * — All Models
	23	26276—80A	GASKET, cover (paper)	84 — FXST; 85 to * — All Models
	24	26277—84	COVER ASSEMBLY, oil pump, includes items 18, 30 & 37	N/A Late 84 — FXST; 85 to * — All Models
	25	26315—68A	DRIVE GEAR	84 — FXST; 85 to * — All Models
	26	26317—68A	IDLER GEAR	84 — FXST; 85 to * — All Models
	27	26326—62A	DRIVE IDLER GEAR	84 — FXST; 85 to * — All Models
	28	26327—68	IDLER SHAFT	84 — FXST; 85 to * — All Models
	29	26328—74	DRIVE GEAR	84 — FXST; 85 to * — All Models
	30	26338—68	ELBOW, oil pump (2)	84 — FXST; 85 to * — All Models
	31	26346—70	DRIVE SHAFT	84 — FXST; 85 to * — All Models
	32	26348—15	KEY, drive shaft (2)	84 — FXST; 85 to * — All Models
	33	26348—36	RETAINING RING, drive shaft	84 — FXST; 85 to * — All Models
	34	26400—82	VALVE, oil pump	84 — FXST; 85 to * — All Models
	36	45830—48	PLUG, oil pump cover	84 — FXST; 85 to * — All Models
	37	63533—41	FITTING, oil line hose (2)	84 — FXST; 85 to * — All Models





RETAIL PRICE	INDEX NO.	PART NO.	NAME	USED ON
	1	2871W	BOLT (2)	84 — FXST; 85 to * — All Models
	2	3494	BOLT (4)	84 — FXST; 85 to * — All Models
	3	3787	BOLT (3)	84 — FXST; 85 — All Models
	4	4017	BOLT (2)	84 — FXST; 85 — All Models
	5	6016	WASHER (5; 3 — 86 & Later)	84 — FXST; 85 to * — All Models
	6	6771	WASHER (4)	84 — FXST; 85 to * — All Models
	7	9991A	CLAMP, compliance fittings (2)	84 — FXST; 85 to * — All Models
	8	10014	CLAMP, fuel hose (2)	84 — FXST; 85 to * — All Models
	9	26558—84	VACUUM SWITCH	84 — FXST; 85 to * — All Models
	10	27008—83A	COMPLIANCE FITTING, front cylinder head	84 — FXST; 85 to * — All Models
		27012—83A	COMPLIANCE FITTING, rear cylinder head	84 — FXST; 85 to * — All Models
	11	27019—83	INTAKE MANIFOLD	84 — FXST; 85 to * — All Models
	12	27023—71	GASKET, carburetor to insulating spacer	Early 85 — All Models
	13	27029—83D	CARBURETOR (02BL)	84 — FXST
		27029—86B	CARBURETOR (02BQ)	86 to * — All Models
	13A	27079—84	CAP, overflow port	84 — FXST; 85 to * — All Models
	14	27130—81	SCREW, throttle stop	84 — FXST; 85 to * — All Models
	15	27136—81	SPRING, throttle stop screw & fast idle screw (2)	84 — FXST; 85 to * — All Models
	16	27137—81	WASHER, throttle stop screw (2)	84 — FXST; 85 to * — All Models
	17	27139—81	SCREW WITH WASHER, throttle cable bracket	84 — FXST; 85 to * — All Models
	18	27143—81	LEVER KIT, accelerator pump	84 — FXST; 85 to * — All Models
	19	27144—83	CHOKE LEVER KIT	84 — FXST; 85 — All Models
		27144—86A	CHOKE LEVER KIT	86 — All Models
	19A	27145—81	SCREW, fast idle	84 — FXST; 85 to * — All Models
	20	27301—86	MAIN JET, 1.70mm	86 to * — All Models
	20A	27302—84	LOW SPEED JET, 0.50mm	84 — FXST; 85 to * — All Models
	21	27304—76	SCREW WITH WASHER, choke cable bracket	84 — FXST; 85 to * — All Models
	22	27307—76	SCREW, wire block	84 — FXST; 85 to * — All Models
	23	27308—76	PIN, float	84 — FXST; 85 to * — All Models
	24	27309—76	SCREW, float pin	84 — FXST; 85 to * — All Models
	25	27311—76	RUBBER CAP, accelerator pump	84 — FXST; 85 to * — All Models
	26	27324—83	O-RING, bowl	84 — FXST; 85 to * — All Models
	27	27325—83	BRACKET, choke cable	84 — FXST; 85 — All Models
		27325—86	BRACKET, choke cable	86 to * — All Models
	28	27327—83	BRACKET, throttle cable	84 — FXST; 85 to * — All Models
	28A	27329—83	LOW SPEED JET, 0.52mm	85 — All Models
	29	27330—83	BOWL (02BH)	84 — FXST; 85 to * — All Models
	30	27333—76	LOCKWASHER, throttle lever	84 — FXST; 85 to * — All Models
	31	27335—76	NUT, throttle lever	84 — FXST; 85 to * — All Models
	33	27360—76	O-RING	84 — FXST; 85 to * — All Models
	34	27361—76	DIAPHRAGM, accelerator pump	84 — FXST; 85 to * — All Models
	35	27362—76	SPRING, diaphragm	84 — FXST; 85 to * — All Models
	36	27366—76	SCREW (5)	84 — FXST; 85 to * — All Models
	37	27367—76	SCREW	84 — FXST; 85 to * — All Models
	38	27368—76	CLIP, overflow hose	84 — FXST; 85 to * — All Models
	39	27369—76	HOSE, overflow	84 — FXST; 85 to * — All Models
	40	27370—83	ROD, accelerator pump	84 — FXST; 85 to * — All Models
	41	27371—76	FITTING	84 — FXST; 85 to * — All Models
	42	27385—76	PLUG, low speed jet	84 — FXST; 85 to * — All Models
	42A	27499—85	CARBURETOR (99BA)	85 — All Models
	43	27886—78	FLOAT VALVE, with clip	84 — FXST; 85 to * — All Models
	44	27887—78	FLOAT	84 — FXST; 85 to * — All Models
	45	27888—78	MAIN JET, 1.60mm	84 — FXST
	46	27891—80	HOUSING, accelerator pump	84 — FXST; 85 to * — All Models
	46A	27898—78	MAIN JET, 1.65mm	85 — All Models
	47	29058—77	GASKET, air cleaner to carburetor (2)	84 — FXST; 85 to * — All Models
	48	29116—83	BRACKET, air cleaner mounting	84 — FXST; 85 — All Models
	49	29242—83	GASKET, compliance fittings (2)	84 — FXST; 85 to * — All Models
	50	29250—78A	INSULATING SPACER	84 — FXST; 85 to * — All Models
	51	45092—66A	CABLE GUIDE	84 — FXST; 85 to * — All Models

# AIR CLEANER AND CHOKE

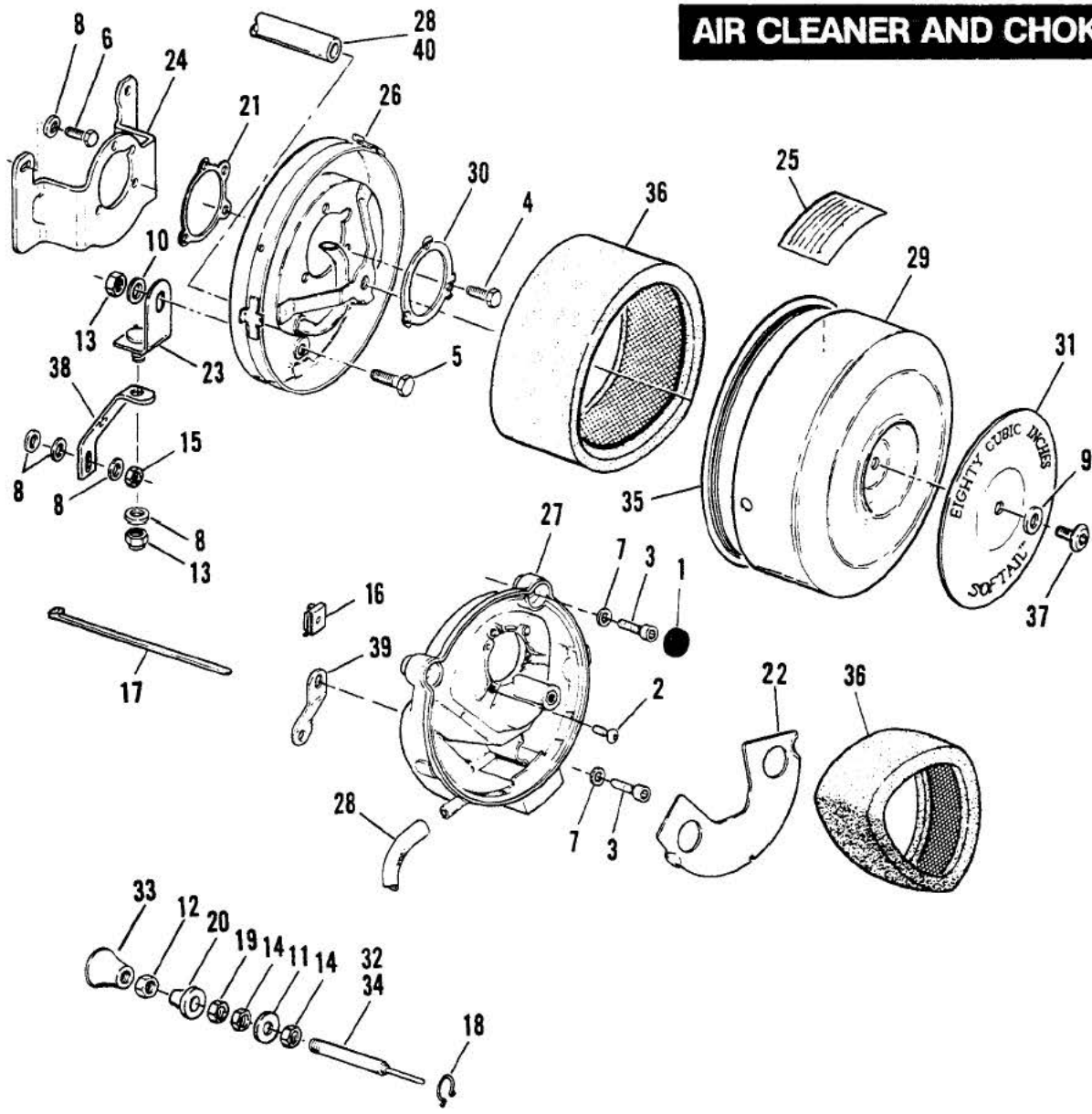

# AIR CLEANER & CHOKE

FX8

RETAIL PRICE	INDEX NO.	PART NO.	NAME	USED ON
	1	738	PLUG, air cleaner back (2)	86 to * — All Models
	2	864	SCREW (3)	86 to * — All Models
	3	3210	SCREW (3)	86 to * — All Models
	4	3787	BOLT (3)	84 — FXST; 85 — All Models
	5	3987	BOLT	84 — FXST; 85 — All Models
	6	4017	BOLT (2)	84 — FXST; 85 — All Models
	7	6002	WASHER (3)	86 to * — All Models
	8	6016	WASHER (6; 3 — 86 & Later)	84 — FXST; 85 to * — All Models
	9	6109	WASHER	84 — FXST; 85 to * — All Models
	10	6702	WASHER	84 — FXST; 85 to * — All Models
	11	7232	LOCKWASHER	84 — FXST; 85 — FXWG
	12	7638	NUT	84 — FXST; 85 to * — All Models
	13	7740	LOCKNUT (2)	84 — FXST; 85 — All Models
	14	7744	JAM NUT (2)	84 — FXST; 85 to * — All Models
	15	7753	NUT	84 — FXST; 85 to * — All Models
	16	8102	SPEED NUT, air cleaner	86 to * — All Models
	17	10006	CABLE STRAP	86 to * — All Models
	18	11013	RETAINING RING, choke cable	84 — FXST; 85 — All Models
	19	27450—82	NUT	84 to * — FXST; 85 & 86 — FXWG
	20	27451—82	GROMMET (black)	84 to * — FXST; 85 & 86 — FXWG
	21	29058—77	GASKET, air cleaner to carburetor	84 — FXST; 85 to * — All Models
	22	29068—86	BAFFLE PLATE, air cleaner	86 to * — All Models
	23	29110—83	BRACKET, air cleaner — bottom	84 — FXST; 85 — All Models
	24	29116—83	BRACKET, air cleaner mounting	84 — FXST; 85 to * — All Models
	25	29126—83	SAFETY LABEL, air cleaner	84 — FXST; 85 to * — All Models
	26	29134—83A	BACK PLATE, air cleaner	84 — FXST; 85 — All Models
	27	29134—86	BACK PLATE, air cleaner	86 to * — All Models
	28	29145—84	HOSE, air cleaner to crankcase	Late 84 — FXST; 85 — All Models
		29145—86	HOSE, air cleaner to crankcase	86 to * — All Models
	29	29165—83A	COVER, air cleaner	84 — FXST; 85 to * — All Models
	30	29168—83A	LOCK PLATE, air cleaner	85 — All Models
	31	29169—84	TRIM, air cleaner — "Softail™"	84 to * — FXST
		29172—85	TRIM, air cleaner — "Low Rider™"	85 — FXSB
		29173—85	TRIM, air cleaner — "Wide Glide™"	85 & 86 — FXWG
		29175—85	TRIM, air cleaner — "Super Glide™"	85 — FXEF
	32	29211—86	CONTROL CABLE, choke	86 to * — All Models
		29213—79	CONTROL CABLE, choke	84 — FXST; 85 & 86 — FXWG
	33	29214—71	KNOB, choke cable	84 to * — FXST; 85 & 86 — FXWG
		29228—80	KNOB, choke cable	85 — FXSB, FXEF
	34	29230—85	CONTROL CABLE, choke	85 — FXSB, FXEF
	35	29252—86B	MOULDING	86 to * — All Models
	36	29259—83A	FILTER ELEMENT	84 — FXST; 85 — All Models
		29259—86	FILTER ELEMENT	86 to * — All Models
	37	29269—83	SCREW	84 — FXST; 85 to * — All Models
	38	29290—83	BRACKET, crankcase to air cleaner bracket	84 — FXST; 85 — All Models
	39	29290—86	BRACKET, air cleaner to crankcase	N/A 86 to * — All Models

NOTE: Hose is sold only in bulk length under the following part number. Cut to required length.

40 63500—68 HOSE, 3/8 I.D. x 5/8 O.D. reinforced rubber - 25 ft. lg. Early 84 — FXST

# ALTERNATOR REGULATOR

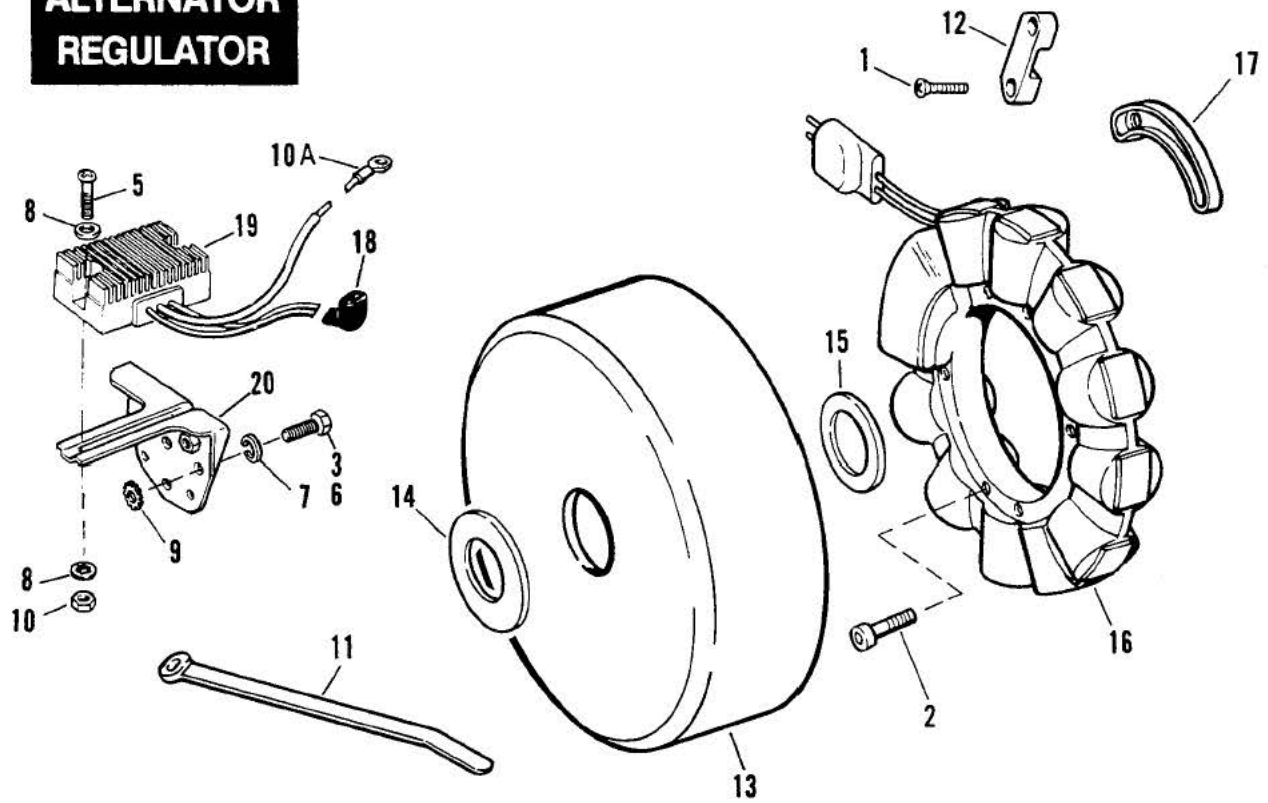

# ALTERNATOR AND REGULATOR

FX9

RETAIL PRICE	INDEX NO.	PART NO.	NAME	USED ON
	1	2216W	SCREW (2)	84 — FXST; 85 to * — All Models
	2	2653	SCREW (4)	84 — FXST; 85 — All Models
		2712	SCREW (4)	86 to * — All Models
	3	2851	BOLT (3 — FXSB)	85 — FXSB, FXST
		2879W	BOLT (3; 2 — 85 & Later)	84 to * — FXST
	5	3802W	BOLT (2)	84 — FXST; 85 to * — All Models
	6	4713W	BOLT (3)	85 to * — FXWG, FXEF
	7	7038	LOCKWASHER (3; 2 — 85 & Later)	84 — FXST; 85 to * — All Models
	8	7124	LOCKWASHER (4; 2 — 86 & Later)	84 — FXST; 85 to * — All Models
	9	7145W	LOCKWASHER (3)	85 to * — All Models
	10	7688	NUT (2)	84 — FXST
	10A	9862	TERMINAL	86 to * — All Models
	11	10006	STRAP, cable	84 to * — FXST; 85 & 86 — FXWG
	12	29954—71	RETAINER, alternator plug	84 — FXST; 85 to * — All Models
	13	29957—81B	ROTOR ASSEMBLY	84 — FXST; 85 to * — All Models
	14	29960—85	SPACER	Late 85 to * — All Models
	15	29961—85	SPACER	Late 85 to * — All Models
	16	29965—81A	STATOR	84 — FXST; 85 to * — All Models
	17	29988—73	LOCKING PLATE, stator (2)	84 — FXST; 85 — All Models
	18	71875—81	CONNECTOR, plug	84 — FXST; 85 — All Models
	19	74516—86	REGULATOR ASSEMBLY	84 — FXST; 85 to * — All Models
	20	74533—75B	BRACKET, regulator (chrome)	85 — FXSB
		74534—80	BRACKET, regulator (black)	84 to * — FXST; 85 & 86 — FXWG, FXEF

# ELECTRONIC IGNITION SYSTEM

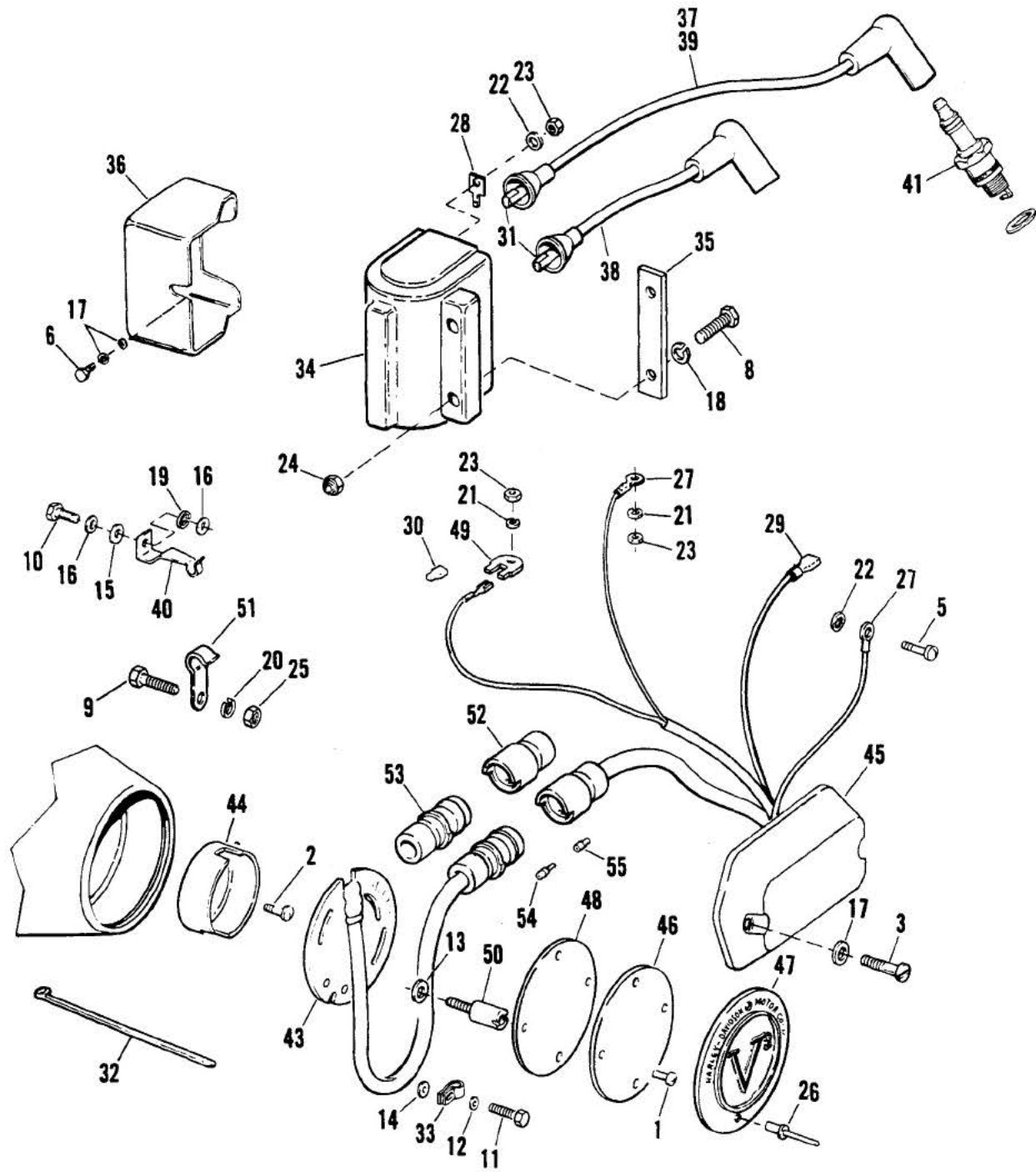

RETAIL PRICE	INDEX NO.	PART NO.	NAME	USED ON
	1	1601	SCREW (2)	84 — FXST; 85 to * — All Models
	2	2611B	SCREW	84 — FXST; 85 to * — All Models
	3	2659	SCREW (2)	84 — FXST
		2665	SCREW (2)	85 to * — All Models
	5	2731W	SCREW	84 to * — FXST; 85 to * — All Models
	6	3473	SCREW (2)	84 to * — FXST
	8	3826	BOLT (2)	84 — FXST
		3993	BOLT (2)	85 to * — All Models
	9	4391	BOLT	85 to * — FXWG, FXST
	10	4726	BOLT	84 — FXST
	11	4813	SCREW	84 — FXST; 85 to * — All Models
	12	6099	WASHER	84 — FXST; 85 to * — All Models
	13	6194	WASHER (2)	84 — FXST; 85 — All Models
	14	6242W	WASHER	84 — FXST; 85 to * — All Models
	15	6497HW	WASHER	84 — FXST
	16	6516HW	WASHER (2)	84 — FXST
	17	6716	WASHER (4; 2 — 86 & Later)	84 — FXST; 85 to * — All Models
	18	7036	LOCKWASHER (2)	85 to * — All Models
	19	7039	LOCKWASHER	84 — FXST
	20	7041	LOCKWASHER	85 to * — FXWG, FXST
	21	7069	LOCKWASHER (4; 2 — 85 & Later)	84 — FXST; 85 to * — All Models
	22	7118	LOCKWASHER (3 — 85 & Later)	84 — FXST; 85 to * — All Models
	23	7638	NUT (2)	84 — FXST; 85 to * — All Models
	24	7683	LOCKNUT (2)	84 — FXST
	25	7753	NUT	85 to * — FXWG, FXST
	26	8699	POP RIVET (2)	84 — FXST; 85 to * — All Models
	27	9857	WIRE TERMINAL, ring type (2)	84 — FXST; 85 to * — All Models
	28	9881	TERMINAL ADAPTOR, spark plug cable	85 to * — FXWG, FXST
	29	9885	CONNECTOR, wire	85 to * — All Models
	30	9900	CONNECTOR, wire	84 — FXST; 85 to * — All Models
	31	9908	TERMINAL, spark plug cable (2)	84 — FXST; 85 to * — All Models
	32	10006	STRAP, wires to frame (2)	84 to * — FXST; 85 & 86 — FXWG
	33	10046	CLAMP, electronic ignition wire	84 — FXST; 85 to * — All Models
	34	31609—80	SPARK COIL, top terminal mounting (not illustrated)	84 — FXST
		31614—83	SPARK COIL, side terminal mounting	85 to * — All Models
	35	31727—72	PLATE, spark coil	84 — FXST
		31727—85	PLATE, spark coil	85 to * — All Models
	36	31800—78A	SPARK COIL COVER KIT (chrome)	84 — FXST; 85 to * — All Models
	37	31981—65B	SPARK PLUG CABLE, front cylinder	85 to * — All Models
	38	31983—71A	SPARK PLUG CABLE, rear cylinder	84 — FXST; 85 to * — All Models
	39	31986—65C	SPARK PLUG CABLE, front cylinder	84 — FXST
	40	32000—37A	BRACKET, spark plug cable	84 — FXST
	41	32311—83	SPARK PLUG, No. 5R6A — 0.04 gap (2)	84 — FXST; 85 to * — All Models
	43	32400—80A	SENSOR ASSEMBLY	84 — FXST; 85 to * — All Models
	44	32402—83	ROTOR	84 — FXST; 85 to * — All Models
	45	32405—88	IGNITION MODULE	84 — FXST; 85 to * — All Models
	46	32504—80	TIMER COVER, inner	84 — FXST; 85 to * — All Models
	47	32524—83	TIMER COVER (polished aluminum)	84 — FXST; 85 to * — All Models
	48	32591—80	GASKET, ignition timer cover	84 — FXST; 85 to * — All Models
	49	32604—78	TERMINAL ADAPTOR, spark coil	84 — FXST; 85 to * — All Models
	50	32606—82	STUD, timer plate (2)	84 — FXST; 85 to * — All Models
	51	67075—57A	BRACKET, spark plug cable	85 to * — All Models
	52	72051—77	CONNECTOR, 2 pins - 1 socket	84 — FXST; 85 to * — All Models
	53	74521—77	RECEPTACLE PLUG, sensor assembly	84 — FXST; 85 to * — All Models
	54	74536—77A	PIN, ignition connectors (3)	84 — FXST; 85 to * — All Models
	55	74539—77A	SOCKET, ignition connectors (3)	84 — FXST; 85 to * — All Models



# STARTER SHAFT AND HOUSING — CHAIN DRIVEN MODELS

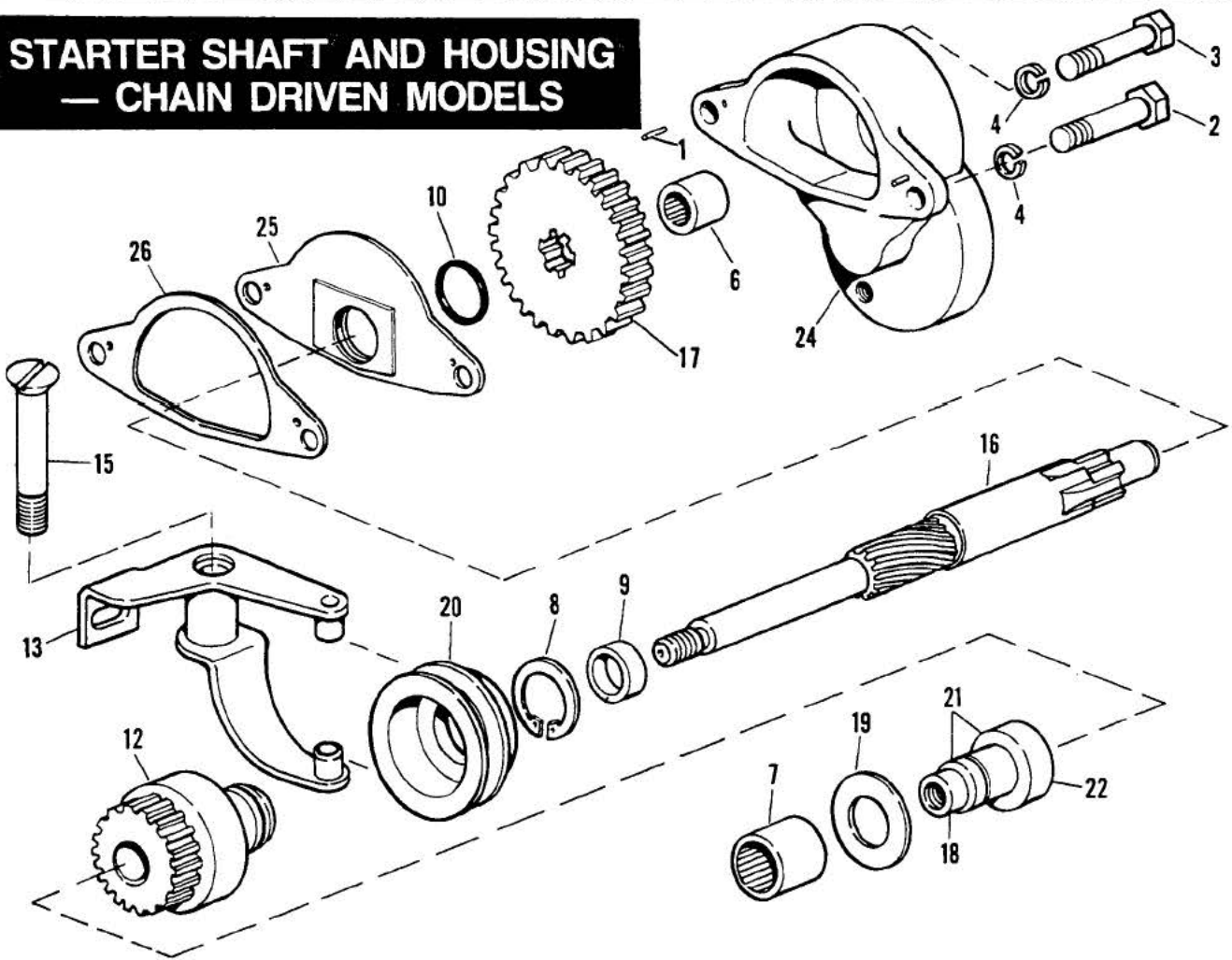

**STARTER SHAFT AND HOUSING — CHAIN DRIVEN MODELS**

**FX11**

RETAIL PRICE	INDEX NO.	PART NO.	NAME	USED ON
	1	334A	ROLL PIN, starter shaft housing (2)	84 & 85 — FXST; 85 — FXEF
	2	2551W	BOLT	84 & 85 — FXST; 85 — FXEF
	3	2872W	BOLT	84 & 85 — FXST; 85 — FXEF
	4	7036	LOCKWASHER (2)	84 & 85 — FXST; 85 — FXEF
	6	9062	NEEDLE BEARING, starter shaft housing	84 & 85 — FXST; 85 — FXEF
	7	9063	NEEDLE BEARING, chain housing cover	84 & 85 — FXST; 85 — FXEF
	8	11039	RETAINING RING, shifter collar	84 & 85 — FXST; 85 — FXEF
	9	11041	SPACER, starter shaft	84 & 85 — FXST; 85 — FXEF
	10	11101	O-RING, deflector plate	84 & 85 — FXST; 85 — FXEF
	12	31443—65A	STARTER DRIVE GEAR UNIT	84 — FXST; Early 85 — FXEF; FXST
	13	31445—65A	SHIFT LEVER, starter gear	84 & 85 — FXST; 85 — FXEF
		31445—85	SHIFT LEVER, starter gear	Late 85 — FXEF, FXST
	15	31478—65A	PIVOT BOLT, shift lever	84 & 85 — FXST; 85 — FXEF
	16	31482—70	STARTER SHAFT	84 & 85 — FXST; 85 — FXEF
	17	31485—65	GEAR, starter shaft	84 & 85 — FXST; 85 — FXEF
	18	31493—67	NUT, starter shaft (L.H. thread)	84 & 85 — FXST; 85 — FXEF
	19	31502—65	THRUST WASHER, chain cover	84 & 85 — FXST; 85 — FXEF
	20	31503—70	SHIFTER COLLAR	84 & 85 — FXST; 85 — FXEF
	22	31531—69	SPACER	84 & 85 — FXST; 85 — FXEF
	24	31572—79	STARTER SHAFT HOUSING, with bearing (Hitachi)	84 & 85 — FXST; 85 — FXEF
	25	60516—65A	PLATE, oil deflector	84 & 85 — FXST; 85 — FXEF
	26	60559—80	GASKET, oil deflector	84 & 85 — FXST; 85 — FXEF

# STARTER SHAFT & HOUSING BELT DRIVEN MODELS

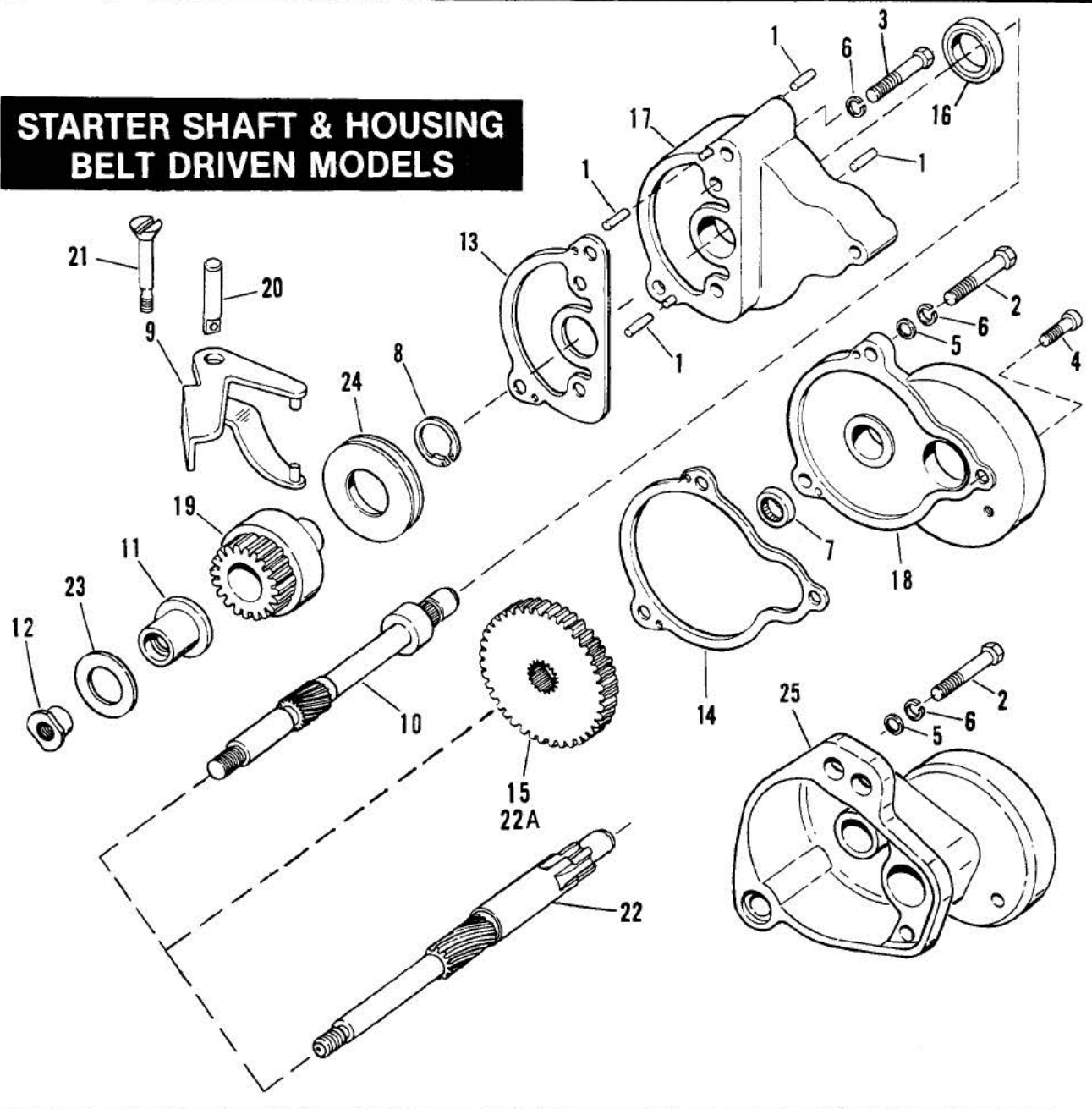

# STARTER SHAFT AND HOUSING — BELT DRIVEN MODELS

FX11A

RETAIL PRICE	INDEX NO.	PART NO.	NAME	USED ON
	1	334A	ROLL PIN, starter shaft housing (4)	85 to * — FXWG, FXSB
	2	2887W	BOLT (2)	86 to * — FXST
		3768	BOLT (2)	85 to * — FXWG, FXSB
	3	3993	BOLT (2)	85 to * — FXWG, FXSB
	4	4741	SCREW	85 to * — FXWG, FXSB
	5	6016	WASHER (2)	86 to * — FXST
		6703	WASHER (2)	85 to * — FXWG, FXSB
	6	7036	LOCKWASHER (4)	85 to * — FXWG, FXSB
		7041	LOCKWASHER (2)	86 to * — FXST
	7	9062	NEEDLE BEARING	85 to * — FXWG, FXSB
	8	11039	RETAINING RING, shaft collar	85 to * — FXWG, FXSB; 86 to * — FXST
	9	31300—84	SHIFTER LEVER, starter gear	85 to * — FXWG, FXSB; 86 to * — FXST
	10	31310—80A	STARTER SHAFT	85 to * — FXWG, FXSB
	11	31311—80	SPACER, starter shaft	85 to * — FXWG, FXSB; 86 to * — FXST
	12	31312—80	NUT, starter shaft	85 to * — FXWG, FXSB; 86 to * — FXST
	13	31320—80	GASKET, starter motor	85 to * — FXWG, FXSB
	14	31321—80	GASKET, starter generator cover	85 to * — FXWG, FXSB
	15	31340—80	GEAR, starter shaft	85 to * — FXWG, FXSB
	16	31341—80	OIL SEAL, starter shaft housing	85 to * — FXWG, FXSB
	17	31387—80	STARTER SHAFT HOUSING	85 to * — FXWG, FXSB
	18	31397—80	STARTER COVER	85 to * — FXWG, FXSB
	19	31443—65A	STARTER DRIVE GEAR	85 to * — FXWG, FXSB; 86 to * — FXST
	20	31473—86	PIVOT SHAFT, see PRIMARY HOUSING	86 to * — FXST
	21	31478—65A	PIVOT BOLT, shift lever	85 to * — FXWG, FXSB
	22	31482—86	STARTER SHAFT	86 to * — FXST
	22A	31485—65	GEAR, starter shaft	85 to * — FXST
	23	31502—65	THRUST WASHER, belt cover	85 to * — FXWG, FXSB; 86 to * — FXST
	24	31503—65	SHIFTER COLLAR	85 to * — FXWG, FXSB
	25	31572—86	STARTER COVER	86 to * — FXST

# STARTER MOTOR

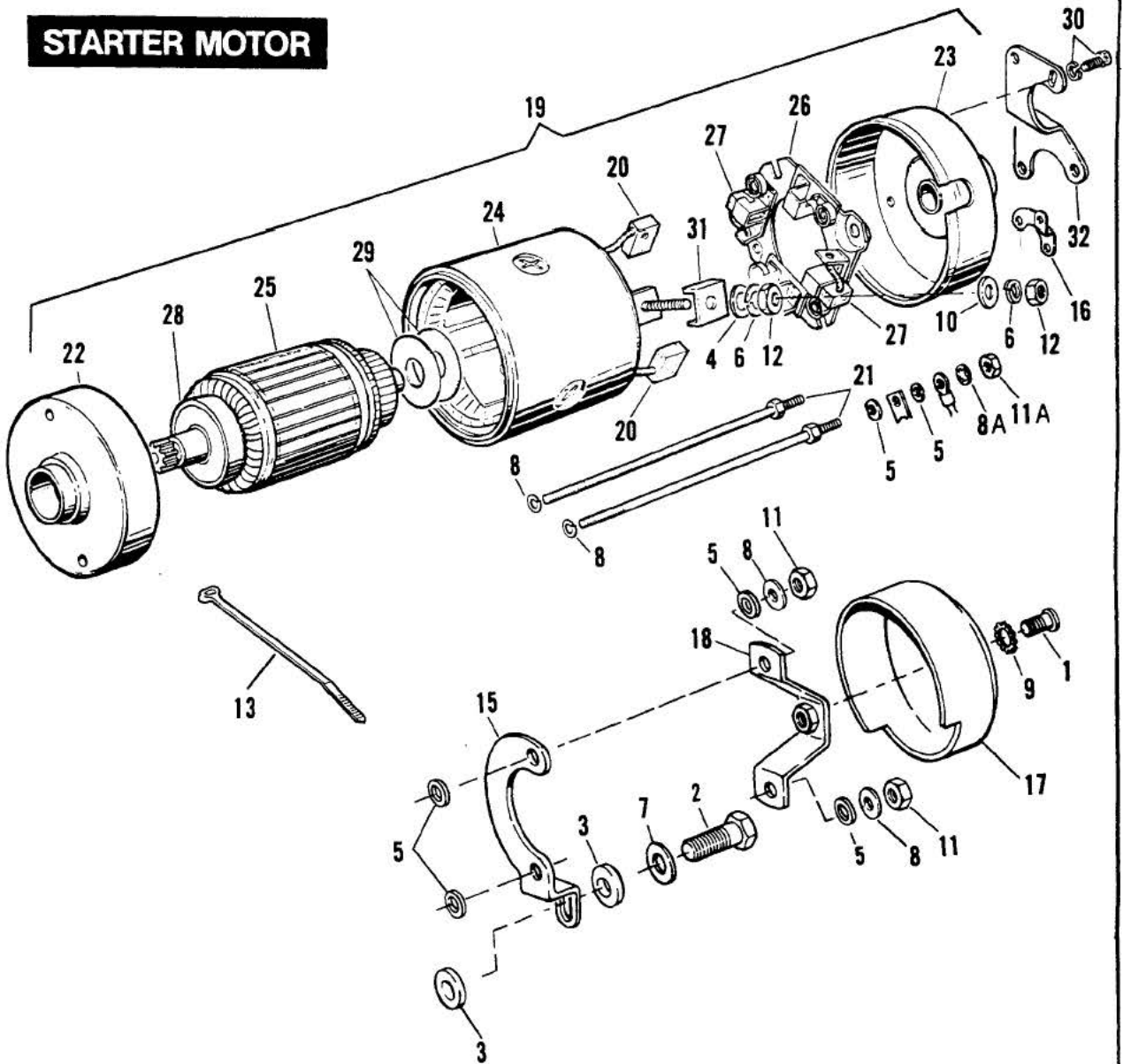

# STARTER MOTOR

FX12

RETAIL PRICE	INDEX NO.	PART NO.	N A M E	USED ON
	1	2682	SCREW .....	86 to * — FXST
	2	4017	BOLT .....	86 to * — FXST
	3	6016	WASHER (2) .....	86 to * — FXST
	4	6703	WASHER .....	84 — FXST; 85 to * — All Models
	5	6716	WASHER (6) .....	84 — FXST; 85 to * — All Models
	6	7036	LOCKWASHER (2) .....	84 — FXST; 85 to * — All Models
	7	7041	LOCKWASHER .....	86 to * — FXST
	8	7069	LOCKWASHER, (4) .....	84 — FXST; 85 to * — All Models
	8A	7118	LOCKWASHER .....	84, Late 85 — FXST; 86 to * — FXWG
	9	7220	LOCKWASHER .....	86 to * — FXST
	10	7230	LOCKWASHER .....	86 to * — FXST
	11	7620W	NUT (2) .....	84 — FXST; 85 to * — All Models
	11A	7624	LOCKNUT (2 — 84; Late 85 — FXST) .....	84 — FXST; 85 — All Models; 86 to * — FXWG
	12	7688	NUT (2) .....	84 — FXST; 85 to * — All Models
	13	10039	STRAP, starter motor wire .....	Early 84 — FXST
	15	31479—83	BRACKET, starter mounting .....	86 to * — FXST
	16—	31480—83	BRACKET, starter motor to transmission .....	84 — FXST
	17	31524—80	COVER, starter motor .....	86 to * — FXST
	18	31564—83	BRACKET, end cover .....	86 to * — FXST
	19	31570—73	STARTER MOTOR (Hitachi) .....	84 — FXST; 85 to * — All Models
	20	31575—73	BRUSH, field coil mounted (2) .....	84 — FXST; 85 to * — All Models
	21	31576—73	SET OF THRU-BOLTS .....	84 — FXST; 85 to * — All Models
	22	31577—73	COVER, drive end .....	84 — FXST; 85 to * — All Models
	23	31578—73	COVER, commutator end — with bushing .....	84 — FXST; 85 to * — All Models
	24	31579—73	FRAME AND FIELD COILS, with 2 brushes .....	84 — FXST; 85 to * — All Models
	25	31580—73	ARMATURE, with ball bearing .....	84 — FXST; 85 to * — All Models
	26	31581—73	BRUSH HOLDER, with 4 springs and 2 brushes .....	84 — FXST; 85 to * — All Models
	27	31582—73	BRUSH (2) .....	84 — FXST; 85 to * — All Models
	28	31583—73	BALL BEARING, armature drive end .....	84 — FXST; 85 to * — All Models
	29	31584—73	SET OF THRUST WASHERS, armature commutator end .....	84 — FXST; 85 to * — All Models
	30	31585—73	SCREW, with lockwasher (2) .....	84 — FXST; 85 to * — All Models
	31	31586—73	INSULATOR, terminal .....	84 — FXST; 85 to * — All Models
	32	66099—80	BRACKET, battery carrier & starter .....	85 to * — FXWG, FXSB
		66225—78	BRACKET, battery carrier & starter .....	85 — FXEF

# KICK STARTER — FXWG, FXSB, FXST

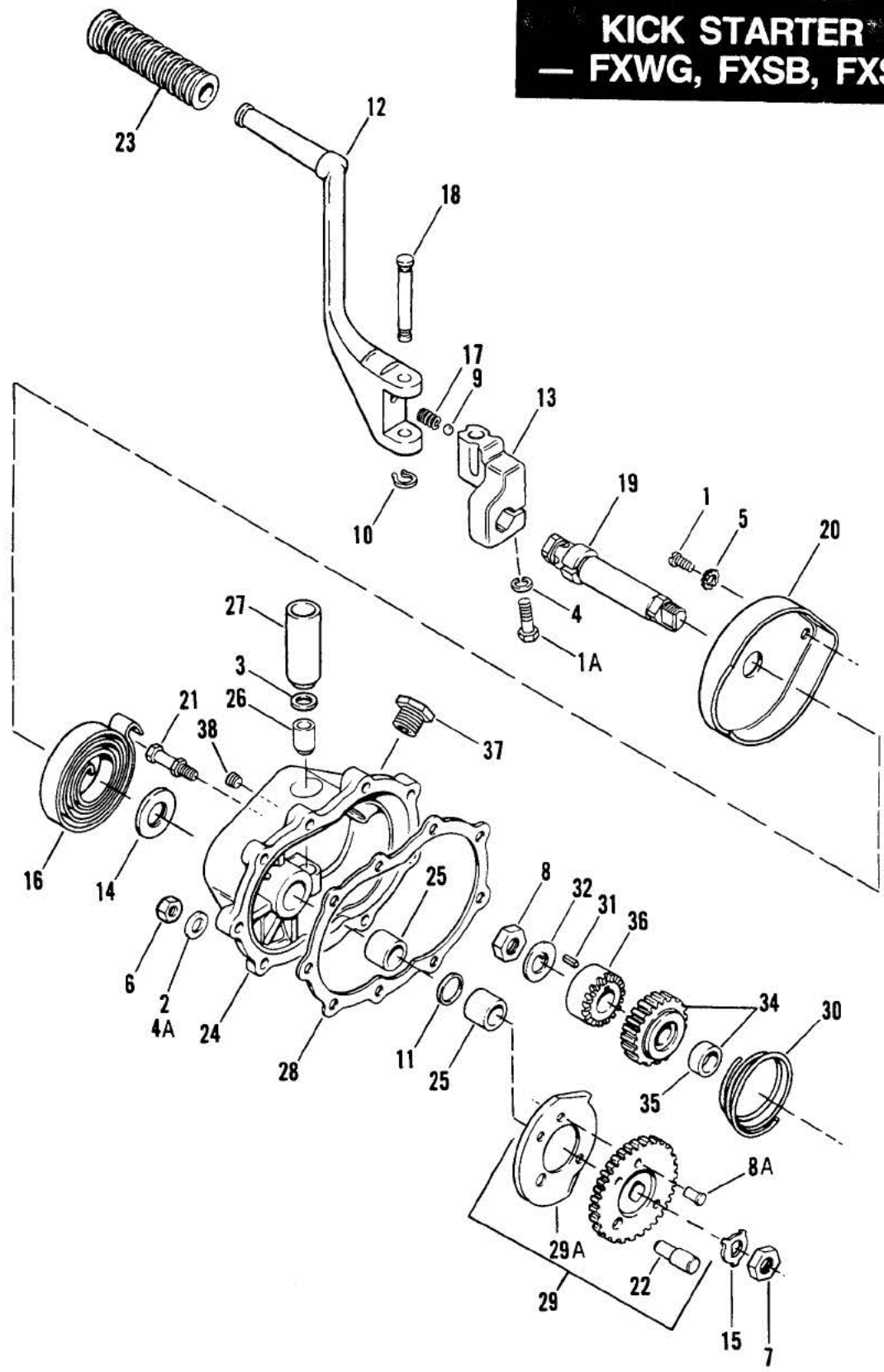

RETAIL PRICE	INDEX NO.	PART NO.	NAME	USED ON
	1	2664	SCREW	84 & 85 — FXST; 85 to * — FXWG, FXSB
	1A	4716W	BOLT	84 & 85 — FXST; 85 to * — FXWG, FXSB
	2	6016	WASHER (9)	84 & 85 — FXST; 85 to * — FXWG, FXSB
	3	6443HW	WASHER	84 & 85 — FXST; 85 to * — FXWG, FXSB
	4	7038	LOCKWASHER	84 & 85 — FXST; 85 to * — FXWG, FXSB
	4A	7041	LOCKWASHER (5)	85 — FXSB
	5	7220	LOCKWASHER	84 & 85 — FXST; 85 to * — FXWG, FXSB
	6	7523	ACORN NUT (5)	85 — FXSB
		7753	NUT (9)	84 & 85 — FXST; 85 to * — FXWG, FXSB
	7	7911	NUT	84 & 85 — FXST; 85 to * — FXWG, FXSB
	8	7977	NUT	84 & 85 — FXST; 85 to * — FXWG, FXSB
	8A	8241	RIVET (3)	84 & 85 — FXST; 85 to * — FXWG, FXSB
	9	8860	BALL, starter crank pedal	84 & 85 — FXST; 85 to * — FXWG, FXSB
	10	11031	RETAINING RING, pivot pin	84 & 85 — FXST; 85 to * — FXWG, FXSB
	11	11101	O-RING, crank shaft	84 & 85 — FXST; 85 to * — FXWG, FXSB
	12	33060—79	STARTER CRANK, only (chrome)	84 & 85 — FXST; 85 to * — FXWG, FXSB
	13	33078—80	BRACKET, starter crank (chrome)	84 & 85 — FXST; 85 to * — FXWG, FXSB
	14	33080—36	WASHER, starter crank	N/A
	15	33082—16	LOCKWASHER, starter crank	84 & 85 — FXST; 85 to * — FXWG, FXSB
	16	33085—36	SPRING, starter crank	84 & 85 — FXST; 85 to * — FXWG, FXSB
	17	33085—74	SPRING, starter crank ball	84 — FXST; 85 — FXWG, FXSB
	18	33086—74	PIVOT PIN, starter crank	84 & 85 — FXST; 85 to * — FXWG, FXSB
	19	33096—54B	STARTER CRANK SHAFT	84 — FXST; 85 — FXWG, FXSB
	20	33151—80	COVER, spring (chrome)	84 — FXST; 85 — FXWG, FXSB
	21	33152—59	STUD, starter spring, with spring cover screw hole	84 — FXST; 85 — FXWG, FXSB
	22	33180—77	PIN, starter crank gear	84 — FXST; 85 — FXWG, FXSB
	23	33189—63	PEDAL COVER (black)	84 & 85 — FXST; 85 to * — FXWG, FXSB
	24	33277—36A	STARTER COVER, transmission cover	84 & 85 — FXST; 85 to * — FXWG, FXSB
	25	33288—37	BUSHING SET, starter crank	84 & 85 — FXST; 85 to * — FXWG, FXSB
	26	33290—38	LOWER BUSHING, starter cover	84 & 85 — FXST; 85 to * — FXWG, FXSB
	27	33291—36	UPPER BUSHING, starter cover	84 — FXST; 85 — FXWG, FXSB
	28	33295—36	GASKET, starter cover	84 & 85 — FXST; 85 to * — FXWG, FXSB
	29	33350—36	GEAR, starter crank — 24 T	84 — FXST; 85 — FXWG, FXSB
	29A	33358—36	CAM PLATE, starter crank gear	84 & 85 — FXST; 85 to * — FXWG, FXSB
	30	33391—36	SPRING, starter clutch	84 & 85 — FXST; 85 to * — FXWG, FXSB
	31	33393—50	KEY, starter clutch	84 — FXST; 85 to * — FXWG, FXSB
	32	33396—39	LOCKWASHER, starter clutch	84 & 85 — FXST; 85 to * — FXWG, FXSB
	34	33430—50	STARTER GEAR, mainshaft — 16 T	84 & 85 — FXST; 85 to * — FXWG, FXSB
	35	33438—50	BUSHING, mainshaft starter gear	84 & 85 — FXST; 85 to * — FXWG, FXSB
	36	33560—75	STARTER CLUTCH	84 — FXST; 85 to * — FXWG, FXSB
	37	37072—79	FILLER PLUG, transmission	84 & 85 — FXST; 85 to * — FXWG, FXSB
	38	45830—48	PLUG, transmission starter cover	84 & 85 — FXST; 85 to * — FXWG, FXSB



# GEAR SHIFTER — 4 SPEED

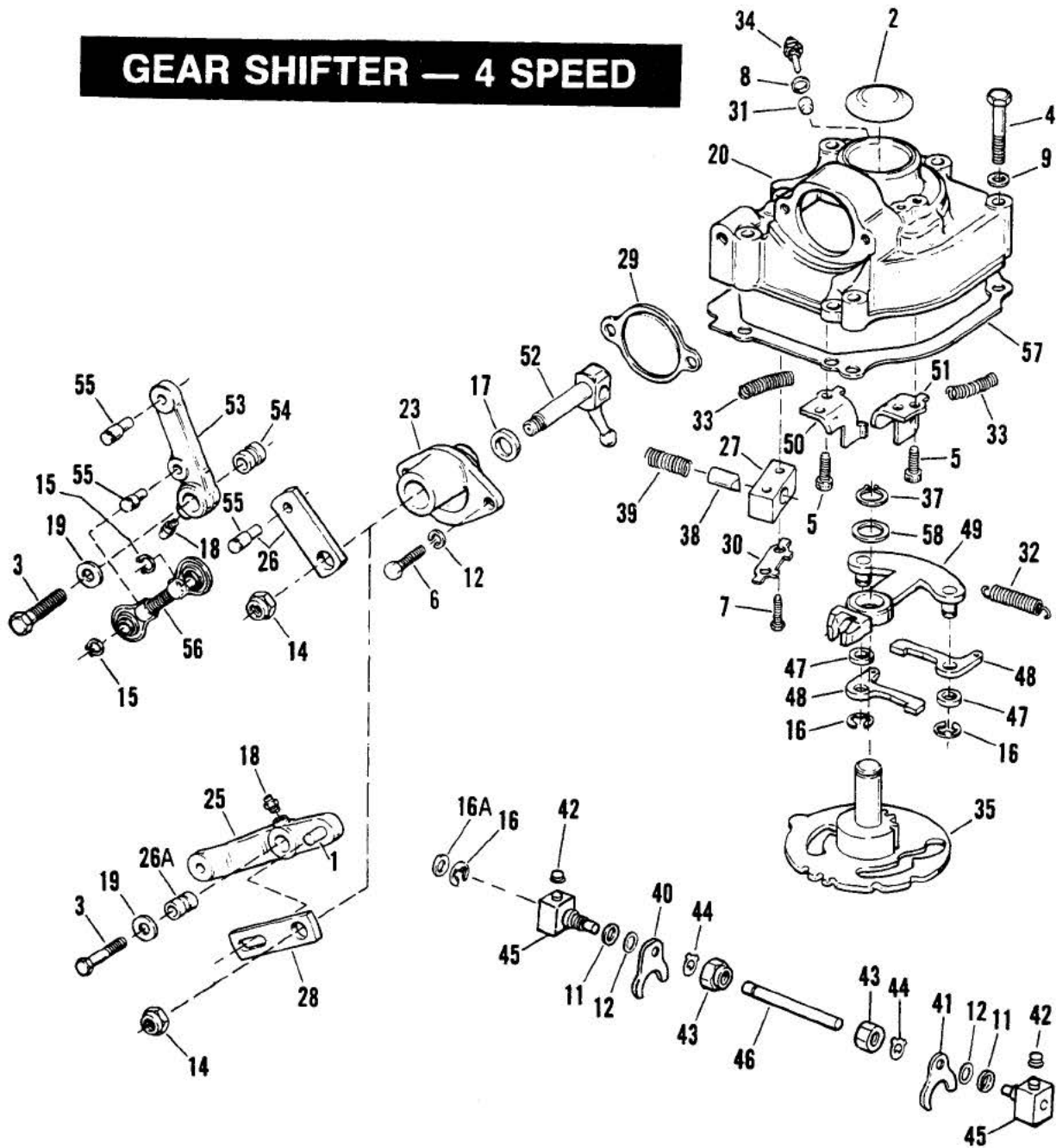

## GEAR SHIFTER — 4 SPEED

FX14-1

RETAIL PRICE	INDEX NO.	PART NO.	NAME	USED ON
		NOTE: See FOOT GEAR SHIFTER for foot lever linkage parts.		
	1	215	PIN, shift lever	84 & 85 — FXST; 85 & 86 — FXWG
	2	650	PLUG, cover	84 — FXST; 85 & 86 — FXWG, FXSB, FXEF
	3	2818	BOLT	84 — FXST; 85 & 86 — FXWG, FXSB, FXEF
	4	2872W	BOLT	84 — FXST; 85 & 86 — FXWG, FXSB, FXEF
		2881W	BOLT (4)	84 — FXST; 85 & 86 — FXWG, FXSB, FXEF
	5	3789A	SCREW (4)	84 — FXST; 85 & 86 — FXWG, FXSB, FXEF
	6	3802W	BOLT (2)	84 — FXST; 85 & 86 — FXWG, FXSB, FXEF
	7	3993	BOLT (2)	84 — FXST; 85 & 86 — FXWG, FXSB, FXEF
	8	6185	WASHER	84 — FXST; 85 & 86 — FXWG, FXSB, FXEF

RETAIL PRICE	INDEX NO.	PART NO.	NAME	USED ON
			NOTE: See FOOT GEAR SHIFTER for foot lever linkage parts.	
	9	6703	WASHER (5)	84 — FXST
		6736	WASHER (5)	85 & 86 — FXWG, FXSB, FXEF
	11	6750	WASHER, 0.007 (as req.)	84 — FXST; 85 & 86 — FXWG, FXSB, FXEF
	12	6752	WASHER, 0.014 (as req.)	84 — FXST; 85 & 86 — FXWG, FXSB, FXEF
		7036	LOCKWASHER (2)	84 — FXST; 85 & 86 — FXWG, FXSB, FXEF
	14	7775	LOCKNUT	84 — FXST; 85 & 86 — FXWG, FXSB, FXEF
	15	11016	RETAINING RING (2)	85 — FXSB, FXEF
	16	11036	RETAINING RING, shifter pawls (3)	84 — FXST; 85 & 86 — FXWG, FXSB, FXEF
	16A	11171	OIL SEAL, shifter cam shaft	84 — FXST; 85 & 86 — FXWG, FXSB, FXEF
	17	12010	OIL SEAL, shaft cover	84 — FXST; 85 & 86 — FXWG, FXSB, FXEF
	18	25715—47	GREASE FITTING, shift lever	84 — FXST; 85 & 86 — FXWG, FXSB, FXEF
	19	32535—48	THRUST WASHER, shift lever (2)	84 — FXST; 85 & 86 — FXWG, FXSB, FXEF
	20	33158—80	SHIFTER COVER ASSEMBLY (footshift)	N/A 84 — FXST
		33165—80	COVER, shifter — with pawls (footshift)	N/A 85 & 86 — FXWG, FXSB, FXEF
		33166—80	COVER, shifter — with pawls (footshift)(painted)	N/A 84 — FXST
		33167—79	COVER, only — (footshift)	84 — FXST; 85 & 86 — FXWG, FXSB, FXEF
		33170—79A	SHIFTER COVER ASSEMBLY (footshift)	N/A 85 — FXST; 85 to * — FXWG, FXSB, FXEF
		33171—79A	SHIFTER COVER ASSEMBLY (footshift)	N/A 85 — FXSB, FXEF
	23	33174—79	COVER, shifter shaft	85 & 86 — FXWG, FXSB, FXEF
		33176—79	COVER, shifter shaft (painted)	N/A 84 — FXST
	25	33177—79	SHIFTER LEVER ASSEMBLY, with fitting and pin	84 & 85 — FXST; 85 & 86 — FXWG
	26	33185—79	SHIFTER ROD ASSEMBLY	85 — FXSB, FXEF
	26A	33187—79	SPACER, shift lever	84 — FXST; 85 & 86 — FXWG, FXSB, FXEF
	27	33188—79	PLUNGER BODY, cam follower	84 — FXST; 85 & 86 — FXWG, FXSB, FXEF
	28	33190—79	ARM, shift lever	84 & 85 — FXST; 85 & 86 — FXWG
	29	33196—79	GASKET, shaft cover	84 — FXST; 85 & 86 — FXWG, FXSB, FXEF
	30	33197—79	LOCK, plunger body bolt	84 — FXST; 85 & 86 — FXWG, FXSB, FXEF
	31	33198—79	BUSHING, neutral switch	84 — FXST; 85 & 86 — FXWG, FXSB, FXEF
	32	33199—79	SPRING, shifter pawls	84 — FXST; 85 & 86 — FXWG, FXSB, FXEF
	33	33201—79	PAWL CARRIER SPRING (2)	84 — FXST; 85 & 86 — FXWG, FXSB, FXEF
	34	33901—79	TRANSMISSION NEUTRAL SWITCH	84 — FXST; 85 & 86 — FXWG, FXSB, FXEF
	35	34020—79B	SHIFTER CAM ASSEMBLY	84 — FXST; 85 & 86 — FXWG, FXSB, FXEF
	37	34040—52	RETAINING RING, shifter cam	84 — FXST; 85 & 86 — FXWG, FXSB, FXEF
	38	34062—52	SHIFTER CAM FOLLOWER	84 — FXST; 85 & 86 — FXWG, FXSB, FXEF
	39	34068—52A	SPRING, shifter cam follower	84 — FXST; 85 & 86 — FXWG, FXSB, FXEF
	40	34158—36	SHIFTER FORK, mainshaft	84 — FXST; 85 & 86 — FXWG, FXSB, FXEF
	41	34159—36	SHIFTER FORK, countershaft	84 — FXST; 85 & 86 — FXWG, FXSB, FXEF
	42	34168—52	ROLLER, shifter finger (2)	84 — FXST; 85 & 86 — FXWG, FXSB, FXEF
	43	34179—33	NUT, bushing (2)	84 — FXST; 85 & 86 — FXWG, FXSB, FXEF
	44	34180—33	LOCKWASHER, bushing (2)	84 — FXST; 85 & 86 — FXWG, FXSB, FXEF
	45	34184—79	SHIFTER FINGER, only (2)	84 — FXST; 85 & 86 — FXWG, FXSB, FXEF
	46	34186—76	FORK SHAFT	84 — FXST; 85 & 86 — FXWG, FXSB, FXEF
	47	34461—72	SPACER, shifter pawl (2)	84 — FXST; 85 & 86 — FXWG, FXSB, FXEF
	48	34476—72	SHIFTER PAWL (2)	84 — FXST; 85 & 86 — FXWG, FXSB, FXEF
	49	34494—74C	PAWL CARRIER	84 — FXST; 85 to * — FXWG, FXSB, FXEF
	50	34517—80	SHIFTER PAWL STOP, rear	84 — FXST; 85 & 86 — FXWG, FXSB, FXEF
	51	34518—80	SHIFTER PAWL STOP, front	84 — FXST; 85 & 86 — FXWG, FXSB, FXEF
	52	34652—80	SHAFT, shifter lever	84 — FXST; 85 & 86 — FXWG, FXSB, FXEF
	53	34655—79	SHIFT LEVER, includes items 18 & 55	85 — FXSB, FXEF
	54	34656—79	SHIFT LEVER	85 — FXSB, FXEF
	55	34658—79	PIN, shift lever (2), shift linkage (1)	85 — FXSB, FXEF
	56	34659—79	ROD, shifter linkage	85 — FXSB, FXEF
	57	34824—79	GASKET, shifter cover	84 — FXST; 85 & 86 — FXWG, FXSB, FXEF
	58	35336—74	THRUST WASHER, shifter cam	84 — FXST; 85 & 86 — FXWG, FXSB, FXEF

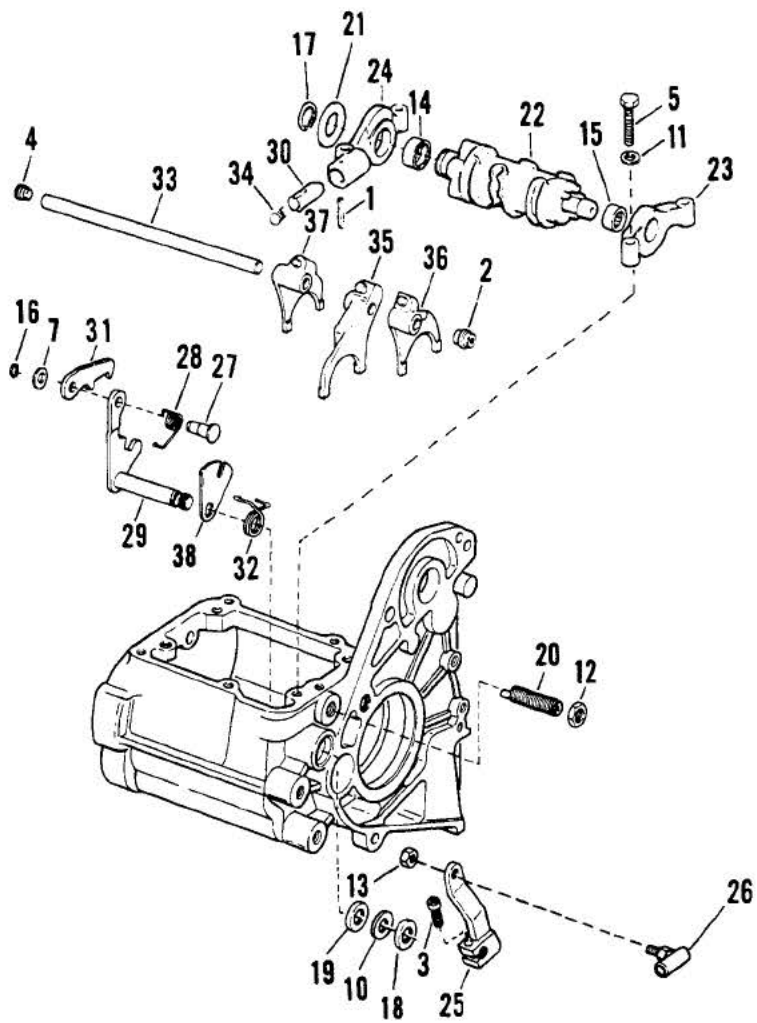

**GEAR SHIFTER — 5 SPEED**

RETAIL PRICE	INDEX NO.	PART NO.	NAME	USED ON
			NOTE: See FOOT GEAR SHIFTER for foot lever linkage parts.	
	1	601	ROLL PIN	86 to * — FXST
	2	721	PLUG, shifter fork shaft — right	86 to * — FXST
	3	856	SCREW	86 to * — FXST
	4	3784	SET SCREW, shifter fork shaft — left	86 to * — FXST
	5	3993	BOLT (4)	86 to * — FXST
	7	6016	WASHER (as required)	86 to * — FXST
	10	6497HW	WASHER	86 to * — FXST
	11	6736	WASHER (4)	86 to * — FXST
	12	7515	JAMNUT	86 to * — FXST
	13	7744	NUT	86 to * — FXST
	14	9114	NEEDLE BEARING, right cam support	86 to * — FXST
	15	9115	NEEDLE BEARING, left cam support	86 to * — FXST
	16	11016	RETAINING RING	86 to * — FXST
	17	11083	RETAINING RING	86 to * — FXST
	18	11150	RETAINING RING	86 to * — FXST
	19	12045	SEAL	86 to * — FXST
	20	33119—79A	ADJUSTING SCREW, shifter arm	86 to * — FXST
	21	33205—80	THRUST WASHER, 0.017 thick	86 to * — FXST
		33206—80	THRUST WASHER, 0.020 thick	86 to * — FXST
		33207—80	THRUST WASHER, 0.022 thick	86 to * — FXST
		33208—80	THRUST WASHER, 0.025 thick	86 to * — FXST
		33209—80	THRUST WASHER, 0.028 thick	86 to * — FXST
		33210—80	THRUST WASHER, 0.031 thick	86 to * — FXST
		33211—80	THRUST WASHER, 0.035 thick	86 to * — FXST
		33212—80	THRUST WASHER, 0.039 thick	86 to * — FXST
	22	33320—79A	SHIFTER CAM	86 to * — FXST
	23	33326—79	SUPPORT, shifter cam — left	86 to * — FXST
	24	33332—79	SUPPORT, shifter cam — right	86 to * — FXST
	25	33715—85	LEVER, transmission shifter rod	86 to * — FXST
	26	33728—82	CONNECTING JOINT	86 to * — FXST
	27	34082—79	PIN, shifter shaft lever	86 to * — FXST
	28	34083—79	SPRING, shifter shaft lever	86 to * — FXST
	29	34084—86	LEVER, shifter shaft w/pin and spring	86 to * — FXST
	30	34085—79A	CAM FOLLOWER	86 to * — FXST
	31	34086—79	PAWL, shifter cam	86 to * — FXST
	32	34087—79	SPRING, shifter shaft	86 to * — FXST
	33	34088—79	SHAFT, shifter fork	86 to * — FXST
	34	34089—79	SPRING	86 to * — FXST
	35	34191—79C	SHIFTER FORK, 1st & 2nd	86 to * — FXST
	36	34193—79C	SHIFTER FORK, 3rd & 5th	86 to * — FXST
	37	34195—79C	SHIFTER FORK, 4th	86 to * — FXST
	38	35068—79	PLATE	86 to * — FXST

# FOOT GEAR SHIFTER

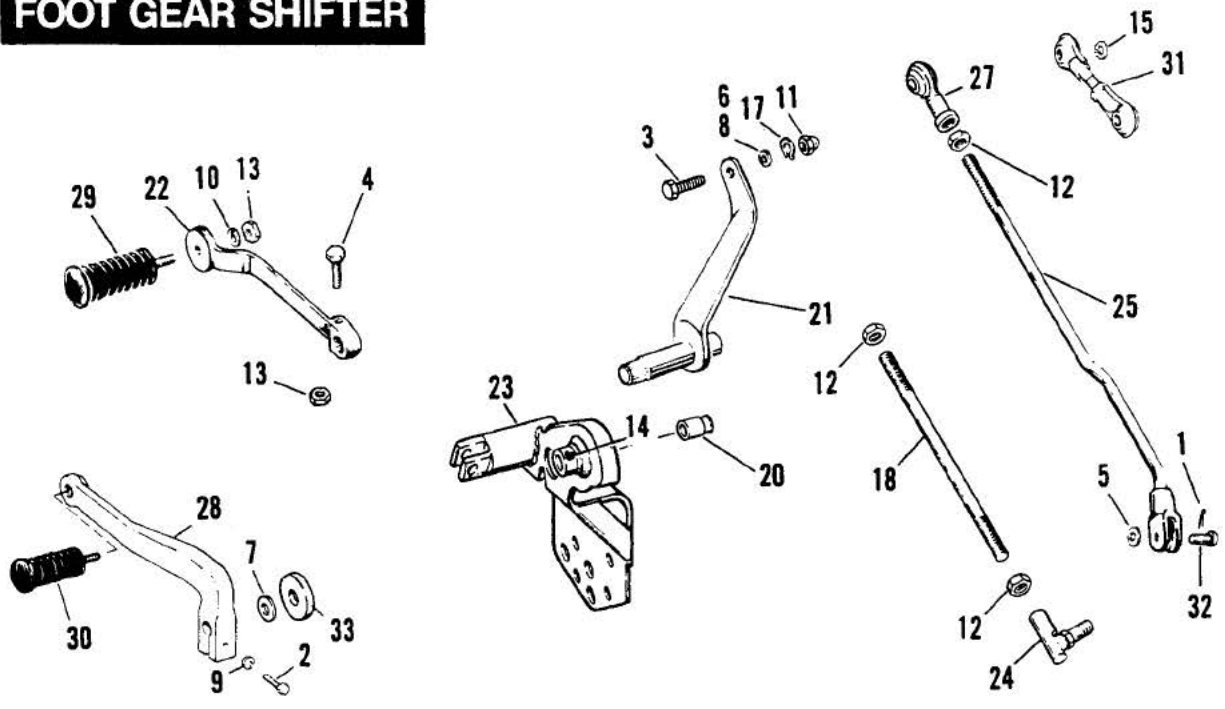

**FOOT GEAR SHIFTER**

**FX14B**

RETAIL PRICE	INDEX NO.	PART NO.	NAME	USED ON
	1	515	COTTER PIN	84 & 85 — FXST; 85 to * — FXWG
	2	2551W	BOLT	85 — FXSB, FXEF; 86 to * — FXWG
	3	3415	BOLT	Late 85 to * — FXWG, FXST
	4	4014W	BOLT	84 & 85 — FXST; 85 to * — FXWG
	5	6220W	WASHER	84 & 85 — FXST; 85 to * — FXWG
	6	6375B	WASHER	84 — FXST; Early 85 — FXWG, FXST
	7	6409	THRUST WASHER	85 — FXSB, FXEF
	8	6702	WASHER	Late 85 to * — FXWG, FXST
	9	7036	LOCKWASHER	85 — FXSB, FXEF; 86 to * — FXST
	10	7041	LOCKWASHER (2)	84 & 85 — FXST; 85 to * — FXWG
	11	7736	ACORN NUT	Late 85 to * — FXWG, FXST
	12	7744	NUT (2 — 86 & Later)	84 to * — FXST; 85 to * — FXWG
	13	7753	NUT (2)	84 & 85 — FXST; 85 to * — FXWG
	14	9851	GREASE FITTING, lever bracket	84 to * — FXST; 85 to * — FXWG
	15	11016	RETAINING RING	85 — FXSB, FXEF
	17	11031	RETAINING RING	84 — FXST; Early 85 — FXWG, FXST
	18	11729	STUD	86 to * — FXST
	20	33638—70	BUSHING, shift lever	84 to * — FXST; 85 to * — FXWG
	21	33660—74A	SHIFT LEVER (chrome)	84 — FXST; Early 85 — FXWG, FXST
		33660—85	SHIFT LEVER (chrome)	Late 85 to * — FXWG, FXST
	22	33664—81	SHIFT LEVER (chrome)	84 & 85 — FXST; 85 to * — FXWG
	23	33683—80	BRACKET, shift lever and foot peg	84 & 85 — FXST; 85 to * — FXWG
		33683—87A	BRACKET, shift lever and foot peg	86 to * — FXST
	24	33728—82A	BALL JOINT	86 to * — FXST
	25	33850—85	SHIFTER ROD	Late 85 — FXST; Late 85 to * — FXWG
	27	33871—67	END, shift rod	84 — FXST; Early 85 — FXWG, FXST
		33871—85	END, shift rod	Late 85 to * — FXWG, FXST
	28	34564—74A	SHIFT LEVER (chrome)	85 — FXSB, FXEF; 86 to * — FXST
		34574—79	SHIFT LEVER	84 & 85 — FXSB, FXEF
	29	34609—52	PEG, shift lever	84 & 85 — FXST; 85 to * — FXWG
	30	34611—65	PEG, shift lever	85 — FXSB, FXEF; 86 to * — FXST
	31	34614—74	SHIFTER ROD	85 — FXSB, FXEF
	32	42269—30	CLEVIS PIN, shift rod	84 & 85 — FXST; 85 to * — FXWG
	33	60400—74	COVER, shift lever bushing	85 — FXSB, FXEF

# TRANSMISSION — MAINSHAFT & HOUSING 4 SPEED

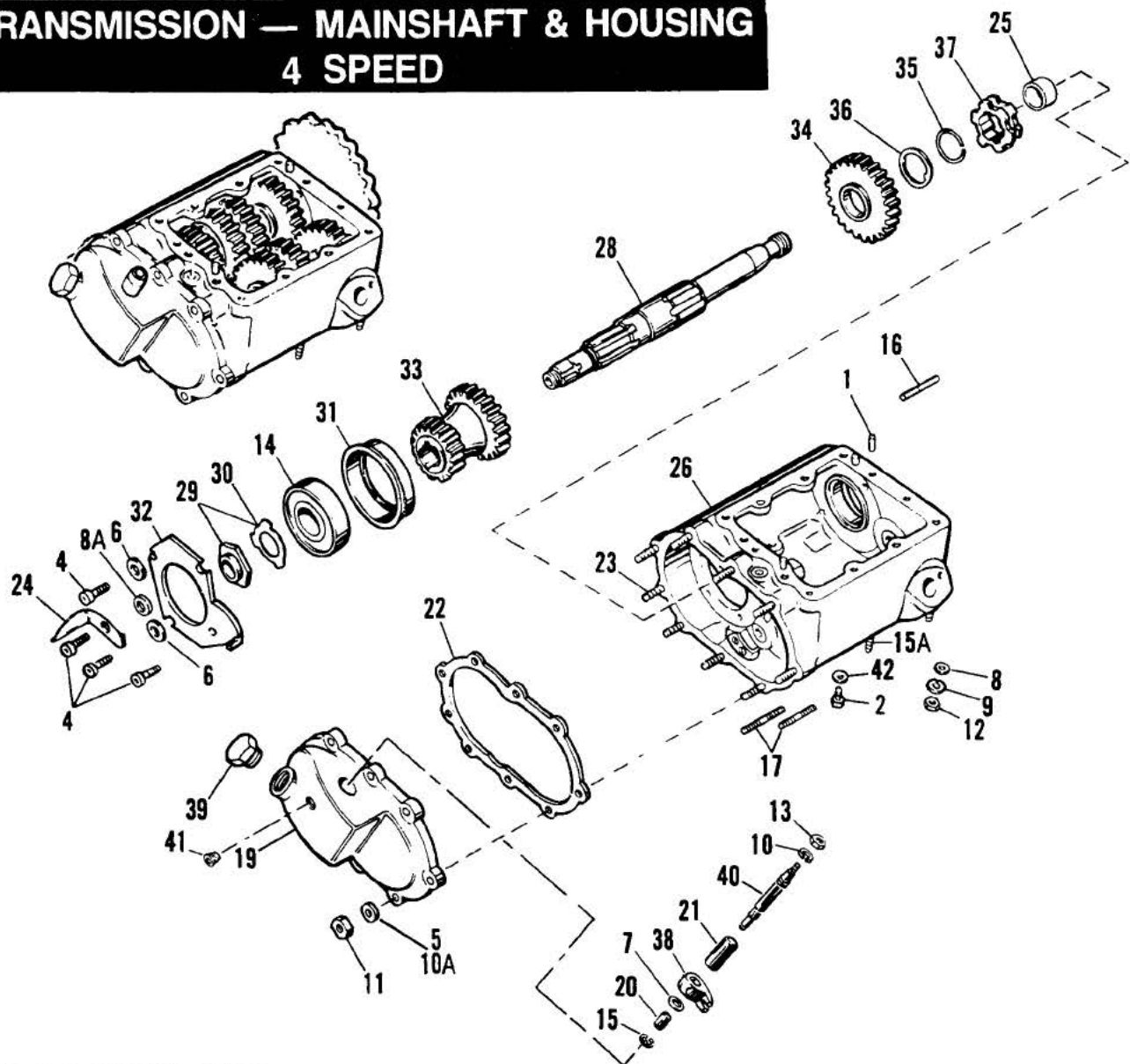

**TRANSMISSION — MAINSHAFT & HOUSING — 4 SPEED**

**FX15**

RETAIL PRICE	INDEX NO.	PART NO.	NAME	USED ON
<b>NOTE:</b> Additional 4 speed mainshaft parts may be found in the next section.				
	1	375	DOWEL PIN (2)	84 & 85 — FXST; 85 & 86 — FXWG, FXSB, FXEF
	2	707	DRAIN PLUG	84 & 85 — FXST; 85 & 86 — FXWG, FXSB, FXEF
	4	3789A	SCREW (4)	84 & 85 — FXST; 85 & 86 — FXWG, FXSB, FXEF
	5	6016	WASHER (9)	84 & 85 — FXST; 85 & 86 — FXWG, FXSB, FXEF
	6	6099	WASHER (2; 3 — FXEF)	84 & 85 — FXST; 85 & 86 — FXWG, FXSB, FXEF
	7	6443HW	WASHER	Late 84 & 85 — FXST; 85 & 86 — FXWG, FXSB, FXEF
	8	6474	WASHER (4)	84 & 85 — FXST; 85 & 86 — FXWG, FXSB, FXEF
	8A	6736	WASHER	85 — All Models; 86 — FXWG
	9	7038	LOCKWASHER (4)	84 & 85 — FXST; 85 & 86 — FXWG, FXSB, FXEF
	10	7039	LOCKWASHER	Late 84 & 85 — FXST; 85 & 86 — FXWG, FXSB, FXEF
	10A	7041	LOCKWASHER (5)	85 — FXSB
	11	7523	ACORN NUT (5)	85 — FXSB
		7753	NUT (9; 4 — FXSB)	84 & 85 — FXST; 85 & 86 — FXWG, FXSB, FXEF
	12	7800W	NUT (4)	84 & 85 — FXST
	13	7837W	NUT	Late 84 & 85 — FXST; 85 & 86 — FXWG, FXSB, FXEF
	14	9020	BALL BEARING, mainshaft	84 & 85 — FXST; 85 & 86 — FXWG, FXSB, FXEF
	15	11000	RETAINING RING	Late 84 & 85 — FXST; 85 & 86 — FXWG, FXSB, FXEF
	15A	11733	TAP STUD, transmission housing (4)	84 & 85 — FXST; 85 & 86 — FXWG, FXSB, FXEF
	16	16830—54	STUD (2)	84 — FXST; 85 & 86 — FXWG, FXSB, FXEF
	17	24823—80	STUD (5)	84 — FXST; 85 & 86 — FXWG, FXSB, FXEF
	19	33276—70	COVER, transmission	85 — FXEF
		33277—36A	COVER, transmission (with kick starter hole)	84 & 85 — FXST; 85 & 86 — FXWG, FXSB
	20	33290—38	LOWER BUSHING, transmission cover	84 & 85 — FXST; 85 & 86 — FXWG, FXSB, FXEF
	21	33291—36	UPPER BUSHING, transmission cover	84 & 85 — FXST; 85 & 86 — FXWG, FXSB, FXEF
	22	33295—36	GASKET, transmission cover	84 & 85 — FXST; 85 & 86 — FXWG, FXSB, FXEF
	23	33298—65	STUD (4)	84 & 85 — FXST; 85 & 86 — FXWG, FXSB, FXEF
	24	33429—80	OIL DEFLECTOR, mainshaft starter gear	Early 84 — FXST
	25	34090—84	INNER RACE, bearing	Late 84 & 85 — FXST; 85 & 86 — FXWG, FXSB, FXEF
	26	34714—82A	TRANSMISSION HOUSING	84 & 85 — FXST; 85 & 86 — FXWG, FXSB, FXEF
	28	35039—80	MAINSHAFT, transmission	Early 84 — FXST
		35039—84	MAINSHAFT, transmission	Late 84 — FXST
		35039—85	MAINSHAFT, transmission	85 — FXST; 85 & 86 — FXWG, FXSB, FXEF
	29	35046—36	NUT, mainshaft bearing, with lockwasher	84 & 85 — FXST; 85 & 86 — FXWG, FXSB, FXEF
	30	35050—40	LOCKWASHER, mainshaft bearing	84 & 85 — FXST; 85 & 86 — FXWG, FXSB, FXEF
	31	35100—79	HOUSING, mainshaft bearing	84 & 85 — FXST; 85 & 86 — FXWG, FXSB, FXEF
	32	35111—80	RETAINING PLATE, bearing housing	84 & 85 — FXST; 85 & 86 — FXWG, FXSB, FXEF
	33	35282—79	GEAR, mainshaft low & second — 17 & 25 T	84 & 85 — FXST; 85 & 86 — FXWG, FXSB, FXEF
	34	35306—59	GEAR, mainshaft third — 24 T	84 & 85 — FXST; 85 & 86 — FXWG, FXSB, FXEF
	35	35337—36	RETAINING RING, mainshaft second & third gears	84 & 85 — FXST; 85 & 86 — FXWG, FXSB, FXEF
	36	35365—36	WASHER, mainshaft second & third gears	84 & 85 — FXST; 85 & 86 — FXWG, FXSB, FXEF
	37	35440—38	CLUTCH, mainshaft	84 & 85 — FXST; 85 & 86 — FXWG, FXSB, FXEF
	38	37070—39B	RELEASE FINGER	Late 84 & 85 — FXST; 85 & 86 — FXWG, FXSB, FXEF
	39	37072—79	FILLER PLUG, transmission cover	84 & 85 — FXST; 85 & 86 — FXWG, FXSB, FXEF
	40	37074—38A	STUD, release lever (finger shaft)	Late 84 & 85 — FXST; 85 & 86 — FXWG, FXSB, FXEF
	41	45830—48	PLUG, transmission cover	85 — FXST; 85 & 86 — FXWG, FXSB, FXEF
	42	62702—52	WASHER, drain plug	84 & 85 — FXST; 85 & 86 — FXWG, FXSB, FXEF



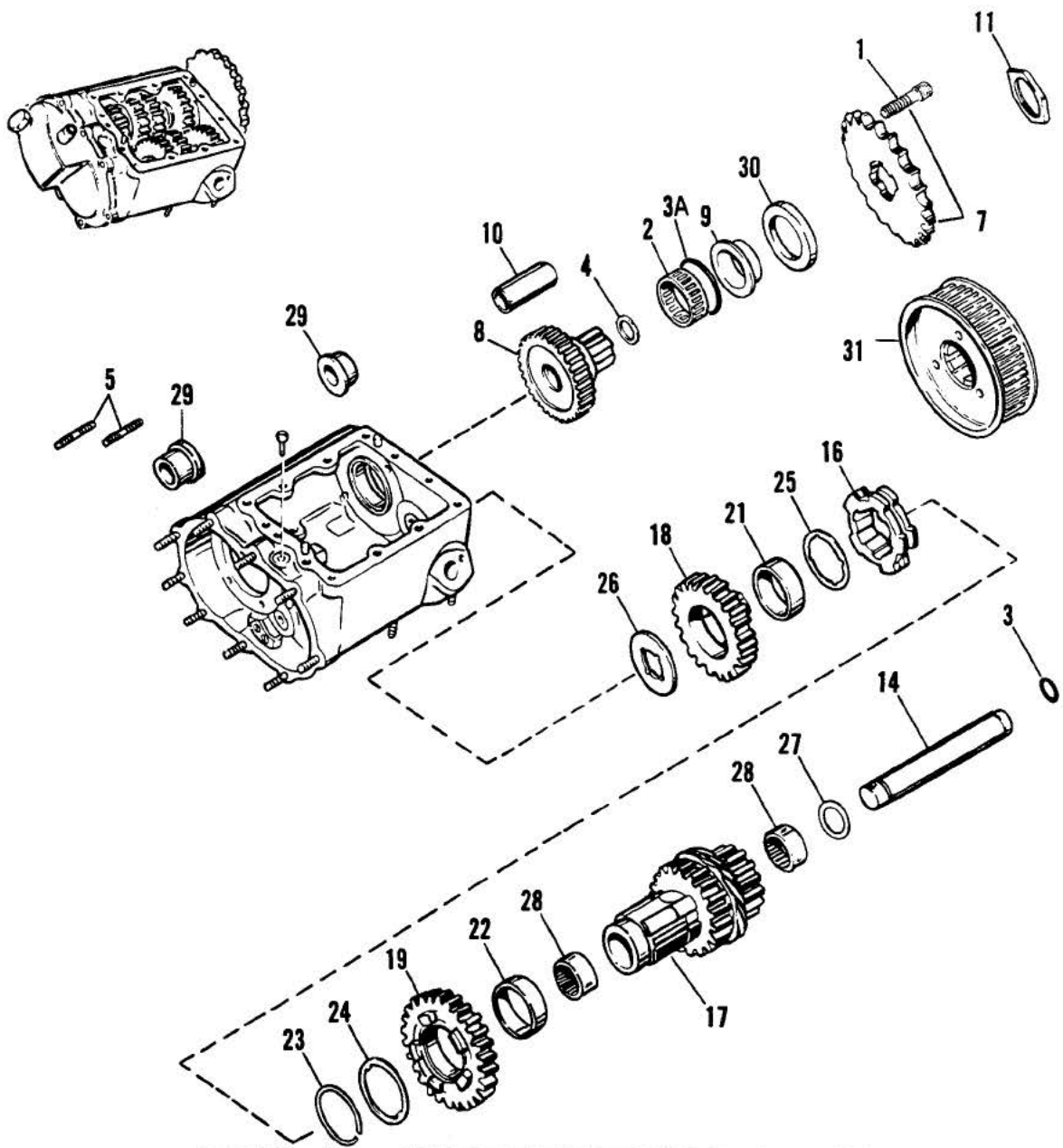

**TRANSMISSION — COUNTERSHAFT — 4 SPEED**

# TRANSMISSION — COUNTERSHAFT — 4 SPEED

FX15A

RETAIL PRICE	INDEX NO.	PART NO.	NAME	USED ON
			NOTE: See previous section for additional 4 speed transmission parts listing.	
	1	857	SCREW, mainshaft sprocket	84 & 85 — FXST; 85 & 86 — FXWG, FXSB, FXEF
	2	8906	NEEDLE BEARING, mainshaft	84 & 85 — FXST; 85 & 86 — FXWG, FXSB, FXEF
	3	11115	O-RING, countershaft	84 & 85 — FXST; 85 & 86 — FXWG, FXSB, FXEF
	3A	11166	O-RING	85 — FXST; 85 & 86 — FXWG, FXSB, FXEF
	4	12013A	OIL SEAL, main drive gear	84 & 85 — FXST; 85 & 86 — FXWG, FXSB, FXEF
	5	24823—80	STUD (5)	84 & 85 — FXST; 85 & 86 — FXWG, FXSB, FXEF
	7	33337—83	SPROCKET KIT, mainshaft — 23 T	84 & 85 — FXST; 85 — FXEF
	8	35067—84	MAIN DRIVE GEAR, 26 T., includes items 3A & 4	84 & 85 — FXST; 85 & 86 — FXWG, FXSB, FXEF
	9	35070—84	SPACER, main drive gear	85 & 86 — FXWG, FXSB
		35079—82A	SPACER, main drive gear	84 — FXST
		35079—84	SPACER, main drive gear	85 — FXEF, FXST
	10	35094—65	BUSHING, main drive gear	84 & 85 — FXST; 85 & 86 — FXWG, FXSB, FXEF
	11	35211—36	LOCKNUT, mainshaft sprocket	84 & 85 — FXST; 85 & 86 — FXWG, FXSB, FXEF
	14	35614—80	COUNTERSHAFT	84 & 85 — FXST; 85 & 86 — FXWG, FXSB, FXEF
	16	35665—36A	CLUTCH, countershaft	84 & 85 — FXST; 85 & 86 — FXWG, FXSB, FXEF
	17	35716—84	GEAR, countershaft — 15 & 17 T	84 & 85 — FXST; 85 & 86 — FXWG, FXSB, FXEF
	18	35717—74	GEAR, countershaft low bushing — 24 T	84 & 85 — FXST; 85 & 86 — FXWG, FXSB, FXEF
	19	35751—79	GEAR, countershaft second with bushing — 24 T	84 & 85 — FXST; 85 & 86 — FXWG, FXSB, FXEF
		35777—79	COUNTERSHAFT GEAR, second	84 & 85 — FXST; 85 & 86 — FXWG, FXSB, FXEF
	21	35789—36	BUSHING, countershaft low & reverse gears	84 & 85 — FXST; 85 & 86 — FXWG, FXSB, FXEF
	22	35791—36	BUSHING, countershaft low & second gears	84 & 85 — FXST; 85 & 86 — FXWG, FXSB, FXEF
	23	35810—36	RETAINING RING, countershaft low & second gears	84 & 85 — FXST; 85 & 86 — FXWG, FXSB, FXEF
	24	35811—36	WASHER, countershaft second & low gears	84 & 85 — FXST; 85 & 86 — FXWG, FXSB, FXEF
	25	35812—36	WASHER, low & reverse gears	84 & 85 — FXST; 85 & 86 — FXWG, FXSB, FXEF
	26	35875—36	SET OF WASHERS, countershaft — gear end	84 & 85 — FXST; 85 & 86 — FXWG, FXSB, FXEF
		35876—36	WASHER, countershaft, gear end — 0.074 thick	84 & 85 — FXST; 85 & 86 — FXWG, FXSB, FXEF
		35877—36	WASHER, countershaft, gear end — 0.078 thick	84 & 85 — FXST; 85 & 86 — FXWG, FXSB, FXEF
		35878—36	WASHER, countershaft, gear end — 0.082 thick	84 & 85 — FXST; 85 & 86 — FXWG, FXSB, FXEF
		35879—36	WASHER, countershaft, gear end — 0.085 thick	84 & 85 — FXST; 85 & 86 — FXWG, FXSB, FXEF
		35882—36	WASHER, countershaft, gear end — 0.090 thick	84 & 85 — FXST; 85 & 86 — FXWG, FXSB, FXEF
		35883—36	WASHER, countershaft, gear end — 0.095 thick	84 & 85 — FXST; 85 & 86 — FXWG, FXSB, FXEF
		35884—36	WASHER, countershaft, gear end — 0.100 thick	84 & 85 — FXST; 85 & 86 — FXWG, FXSB, FXEF
	27	35915—36	RETAINING WASHER, countershaft bearing (outer)	84 & 85 — FXST; 85 & 86 — FXWG, FXSB, FXEF
	28	35961—52	NEEDLE BEARING, countershaft (2)	84 & 85 — FXST; 85 & 86 — FXWG, FXSB, FXEF
	29	36048—76A	BUSHING, countershaft (clutch & starter side)	84 & 85 — FXST; 85 & 86 — FXWG, FXSB, FXEF
	30	37741—82	OIL SEAL, mainshaft	84 & 85 — FXST; 85 & 86 — FXWG, FXSB, FXEF
	31	40212—80C	SPROCKET, belt	85 — FXSB; 85 & 86 — FXWG

# TRANSMISSION HOUSING 5 SPEED

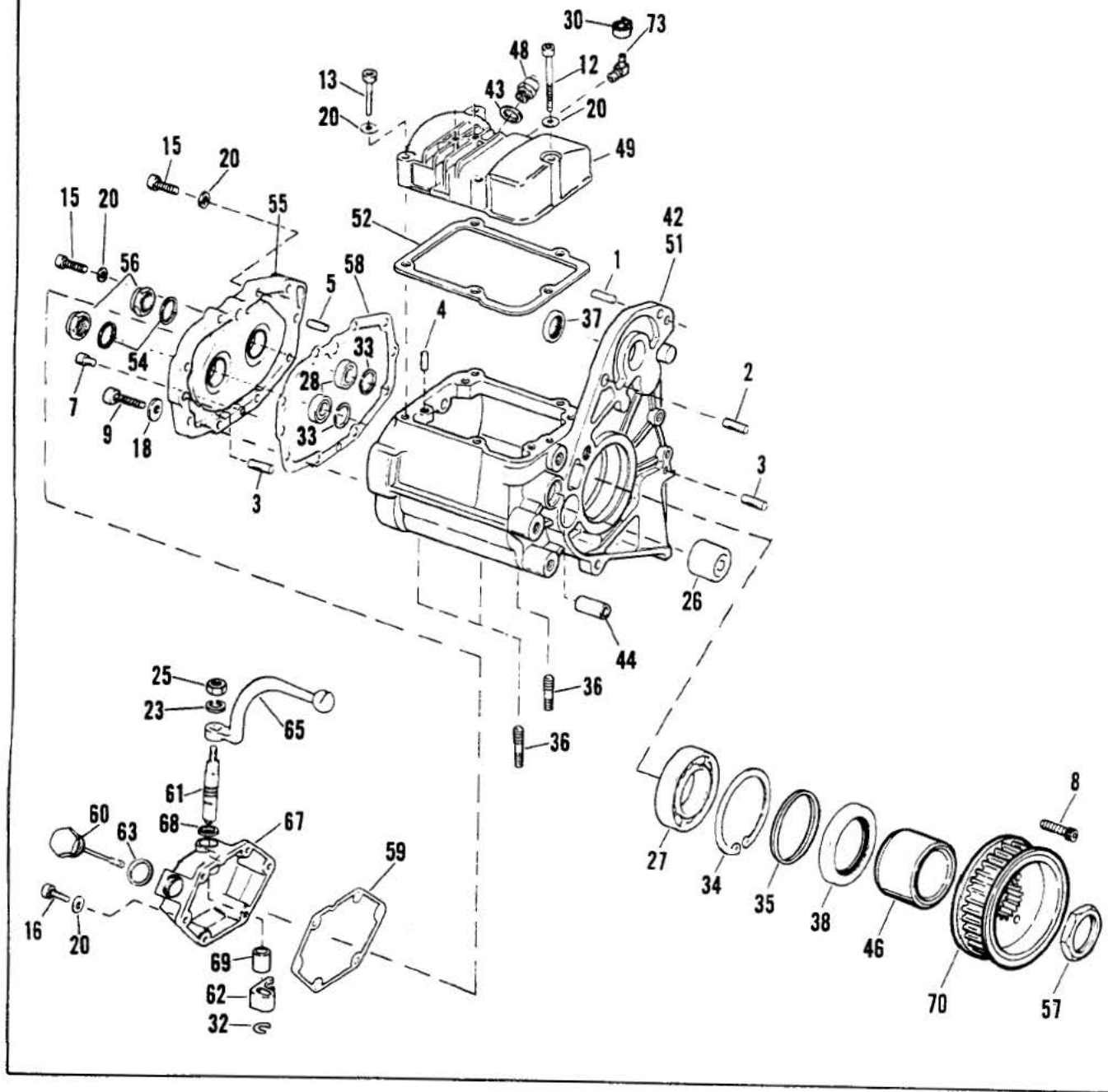

RETAIL PRICE	INDEX NO.	PART NO.	NAME	USED ON
	1	335	PIN .....	86 to * — FXST
	2	336	DOWEL PIN .....	86 to * — FXST
	3	375	DOWEL PIN (2) .....	86 to * — FXST
	4	609	PIN (2) .....	86 to * — FXST
	5	634	PIN .....	86 to * — FXST
	7	739	DRAIN PLUG (magnetic) .....	86 to * — FXST
	8	857	SCREW .....	86 to * — FXST
	9	3210	SCREW (4) .....	86 to * — FXST
	12	4717	SCREW .....	86 to * — FXST
	13	4718	SCREW (4) .....	86 to * — FXST
	15	4814	SCREW (4) .....	86 to * — FXST
	16	4815	SCREW (6) .....	86 to * — FXST
	18	6016	WASHER (4) .....	86 to * — FXST
	20	6099	WASHER (9) .....	86 to * — FXST
	23	7041	LOCKWASHER .....	86 to * — FXST
	25	7748W	NUT .....	86 to * — FXST
	26	8977	NEEDLE BEARING .....	86 to * — FXST
	27	8996	BALL BEARING, mainshaft — clutch side .....	86 to * — FXST
	28	8998	BALL BEARING (2) .....	86 to * — FXST
	30	10014	CLAMP .....	86 to * — FXST
	32	11019	RETAINING RING .....	86 to * — FXST
	33	11020	RETAINING RING, bearing (2) .....	86 to * — FXST
	34	11161	RETAINING RING, ball bearing .....	86 to * — FXST
	35	11165	QUAD SEAL, ball bearing .....	86 to * — FXST
	36	11733	STUD (5) .....	86 to * — FXST
	37	12051	OIL SEAL, transmission to starter .....	86 to * — FXST
	38	12050	OIL SEAL, mainshaft — clutch side .....	86 to * — FXST
	43	33043—80	WASHER, neutral indicator switch .....	86 to * — FXST
	44	33114—79	SPACER .....	86 to * — FXST
	46	33334—85	SPACER, sprocket .....	86 to * — FXST
	48	33900—59	SWITCH, transmission neutral indicator .....	86 to * — FXST
	49	34464—86	COVER, upper (polished) .....	86 to * — FXST
	51	34731—86A	TRANSMISSION HOUSING .....	86 to * — FXST
	52	34904—86	GASKET, upper cover .....	86 to * — FXST
	54	35076—79	SPACER (2) .....	86 to * — FXST
	55	35077—86A	HOUSING, w/bearings & rings .....	86 to * — FXST
	56	35078—79	NUT, mainshaft & countershaft (2) .....	86 to * — FXST
	57	35211—36	NUT, sprocket .....	86 to * — FXST
	58	35652—79A	GASKET, bearing housing .....	86 to * — FXST
	59	36801—79	GASKET, right side cover .....	86 to * — FXST
	60	37071—79	FILL PLUG, with dipstick (polished) .....	86 to * — FXST
	61	37083—80A	STUD, release lever .....	86 to * — FXST
	62	37084—79	RELEASE FINGER .....	86 to * — FXST
	63	37091—80	WASHER .....	86 to * — FXST
	65	37096—85	RELEASE LEVER .....	86 to * — FXST
	67	37100—84	CLUTCH RELEASE COVER ASSEMBLY, w/items 68 & 69 .....	86 to * — FXST
	68	37101—84	OIL SEAL, clutch release lever .....	86 to * — FXST
	69	37102—84	BUSHING, clutch release lever stud .....	86 to * — FXST
	70	40210—85A	SPROCKET, 32 T, belt .....	86 to * — FXST
	73	62375—57	FITTING, upper cover .....	86 to * — FXST

# TRANSMISSION GEARS — 5 SPEED

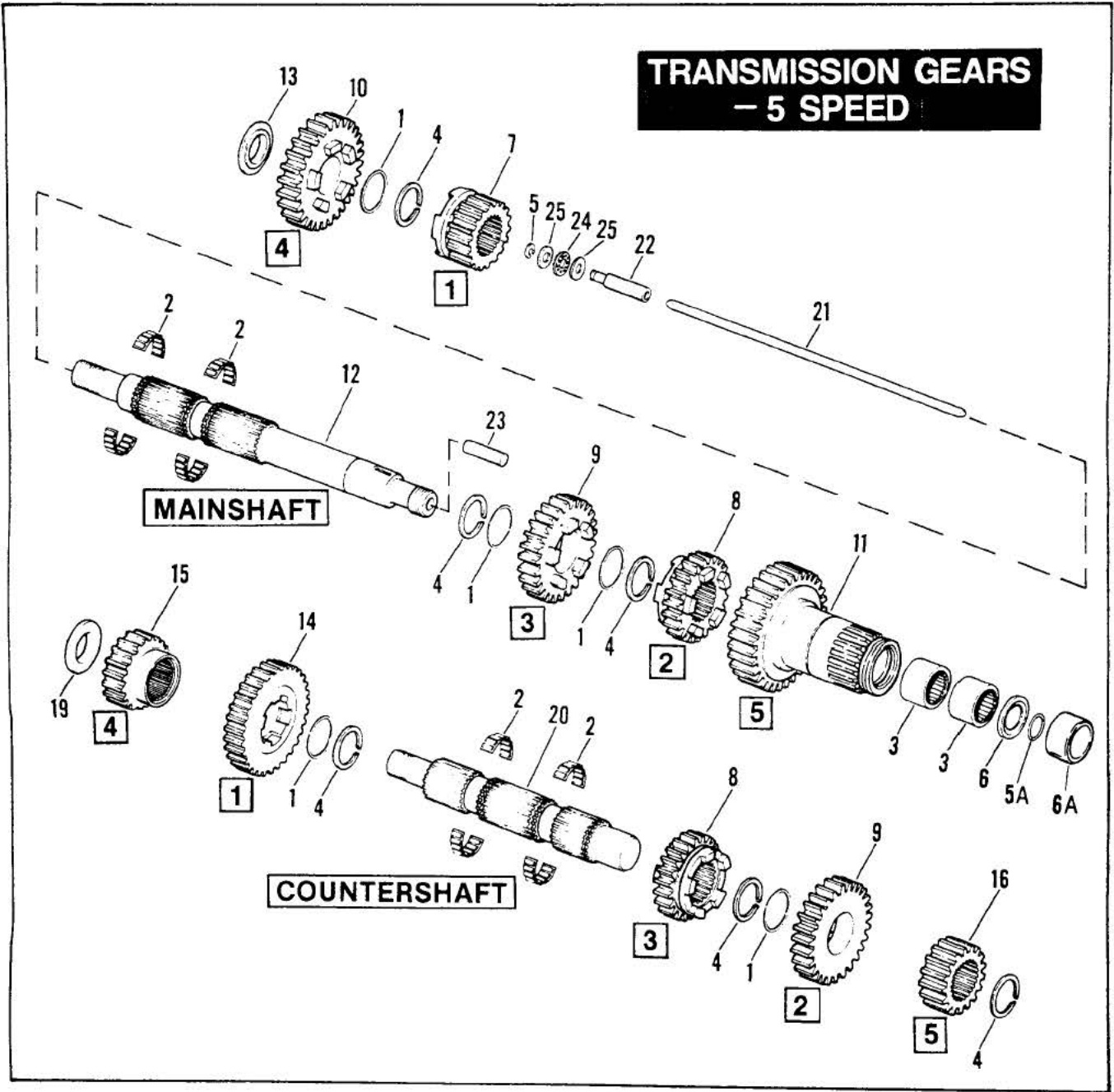

# TRANSMISSION GEARS — 5 SPEED

FX16A

RETAIL PRICE	INDEX NO.	PART NO.	NAME	USED ON
	1	6003	THRUST WASHER (5)	86 to * — FXST
	2	8876A	BEARING (4)	86 to * — FXST
	3	8904	NEEDLE BEARING, mainshaft fifth gear (2)	86 to * — FXST
	4	11067	RETAINING RING (6)	86 to * — FXST
	5	11096	RETAINING RING	86 to * — FXST
	5A	11165	O-RING, mainshaft — right end	86 to * — FXST
	6	12013A	OIL SEAL, mainshaft fifth gear	86 to * — FXST
	6A	34091—85	BEARING, inner race	86 to * — FXST
	7	35025—79	FIRST GEAR, mainshaft	86 to * — FXST
	8	35026—79A	GEAR, mainshaft second & countershaft third (2)	86 to * — FXST
	9	35027—79A	GEAR, mainshaft third & countershaft second (2)	86 to * — FXST
	10	35028—79	FOURTH GEAR, mainshaft	86 to * — FXST
	11	35029—85A	FIFTH GEAR, mainshaft	86 to * — FXST
	12	35042—85	MAINSHAFT	86 to * — FXST
	13	35064—79	SPACER, mainshaft	86 to * — FXST
	14	35622—79A	FIRST GEAR, countershaft	86 to * — FXST
	15	35625—79A	FOURTH GEAR, countershaft	86 to * — FXST
	16	35626—79A	FIFTH GEAR, countershaft	86 to * — FXST
	19	35629—79	SPACER	86 to * — FXST
	20	35632—79	COUNTERSHAFT	86 to * — FXST
	21	37088—85	PUSH ROD, clutch release (thru mainshaft)	86 to * — FXST
	22	37089—84	END, clutch push rod — right side	86 to * — FXST
	23	37090—84	END, clutch push rod — left side	86 to * — FXST
	24	37312—75	BEARING	86 to * — FXST
	25	37313—80	THRUST WASHER (2)	86 to * — FXST

# CLUTCH — EARLY 1984

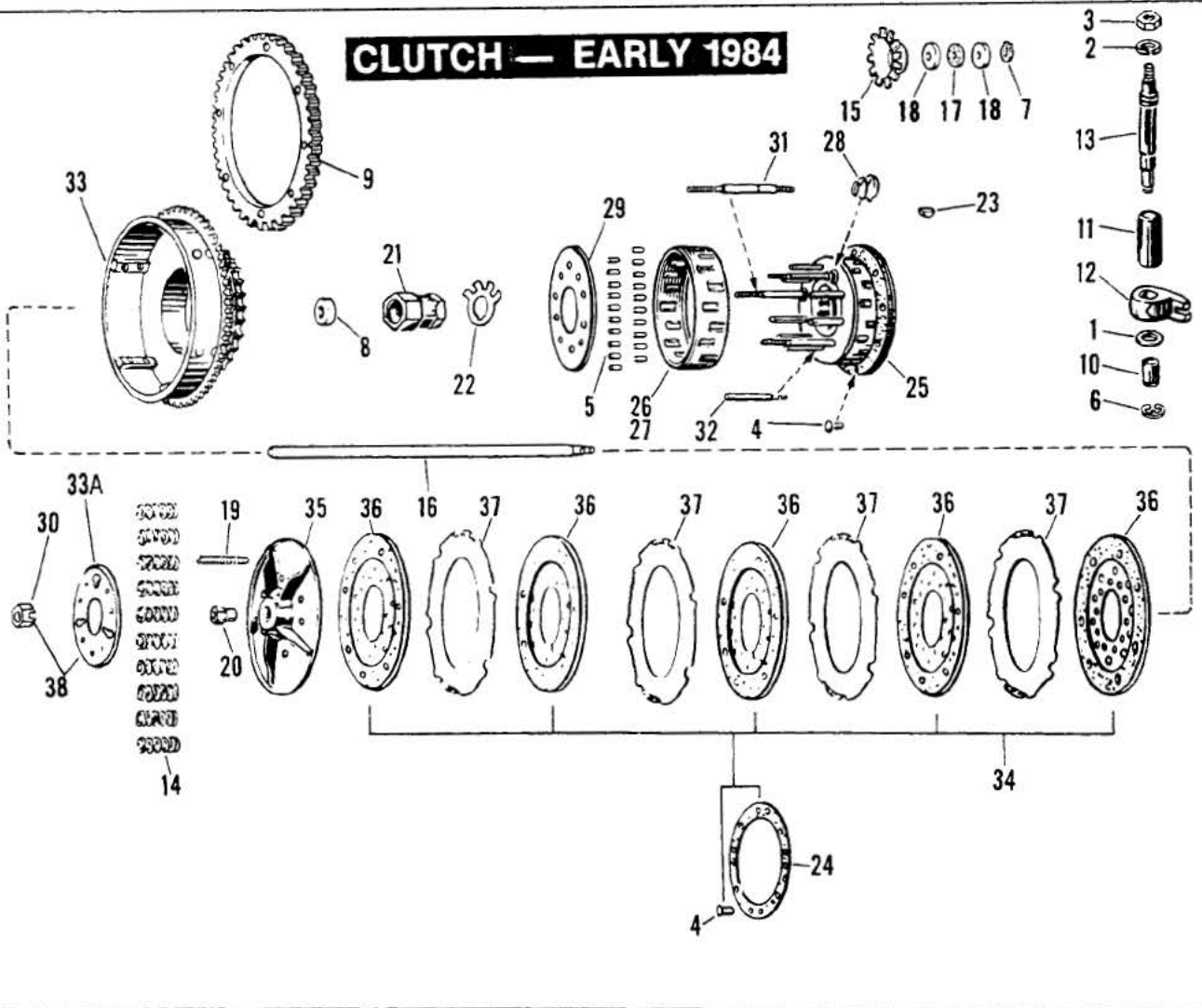

# CLUTCH — EARLY 1984

FX17

RETAIL PRICE	INDEX NO.	PART NO.	NAME	USED ON
	1	6443HW	WASHER	Early 84 — FXST
	2	7039	LOCKWASHER	Early 84 — FXST
	3	7837W	NUT	Early 84 — FXST
	4	8227	RIVET (brass) (8)	Early 84 — FXST
	5	9540A	ROLLER, clutch hub bearing (20)	Early 84 — FXST
	6	11000	RETAINING RING	Early 84 — FXST
	7	11096	RETAINING RING	Early 84 — FXST
	8	12014	OIL SEAL, mainshaft nut	Early 84 — FXST
	9	33163—65B	STARTER RING GEAR	Early 84 — FXST
	10	33290—38	BUSHING, release lever shaft (lower)	Early 84 — FXST
	11	33291—36	BUSHING, release lever shaft (upper)	Early 84 — FXST
	12	37070—39B	RELEASE FINGER	Early 84 — FXST
	13	37074—38A	STUD, release lever (finger shaft)	Early 84 — FXST
	14	37077—68	CLUTCH SPRING (10)	Early 84 — FXST
	15	37228—75	OIL SLINGER	Early 84 — FXST
	16	37285—75A	PUSH ROD, clutch	Early 84 — FXST
	17	37312—75	BEARING, push rod	Early 84 — FXST
	18	37313—80	THRUST WASHER, inner (2)	Early 84 — FXST
	19	37357—41	ADJUSTING SCREW, push rod	Early 84 — FXST
	20	37361—41	NUT, adjusting screw	Early 84 — FXST
	21	37496—65	NUT, mainshaft (clutch side)	Early 84 — FXST
	22	37503—41	LOCKWASHER, clutch nut	Early 84 — FXST
	23	37523—15A	KEY, clutch	Early 84 — FXST
	24	37549—41	LINING, hub friction disc	Early 84 — FXST
	25	37550—41B	CLUTCH HUB ASSEMBLY	Early 84 — FXST
	26	37566—58	RETAINER, clutch hub roller	Early 84 — FXST
	27	37567—41A	RETAINER, clutch hub roller — with rollers	Early 84 — FXST
	28	37574—44	SPRING, hub bearing plate (3)	Early 84 — FXST
	29	37576—41	PLATE, hub bearing	Early 84 — FXST
	30	37581—47	NUT, hub stud (3)	Early 84 — FXST
	31	37583—41	STUD, drive hub (3)	Early 84 — FXST
	32	37585—41	PIN, clutch hub (7)	Early 84 — FXST
	33	37702—70A	CLUTCH SHELL & SPROCKET, with starter ring gear	Early 84 — FXST
	33A	37816—41	PRESSURE PLATE	Early 84 — FXST
	34	37850—68	SET OF LINED CLUTCH DISCS	Early 84 — FXST
	35	37871—41	RELEASING DISC	Early 84 — FXST
	36	37930—68A	FRICTION DISC (5)	Early 84 — FXST
	37	37975—81	DRIVE DISC (steel) (4)	Early 84 — FXST
	38	38010—41	PRESSURE PLATE, includes item 30	N/A Early 84 — FXST



# CLUTCH - LATE 1984 AND LATER

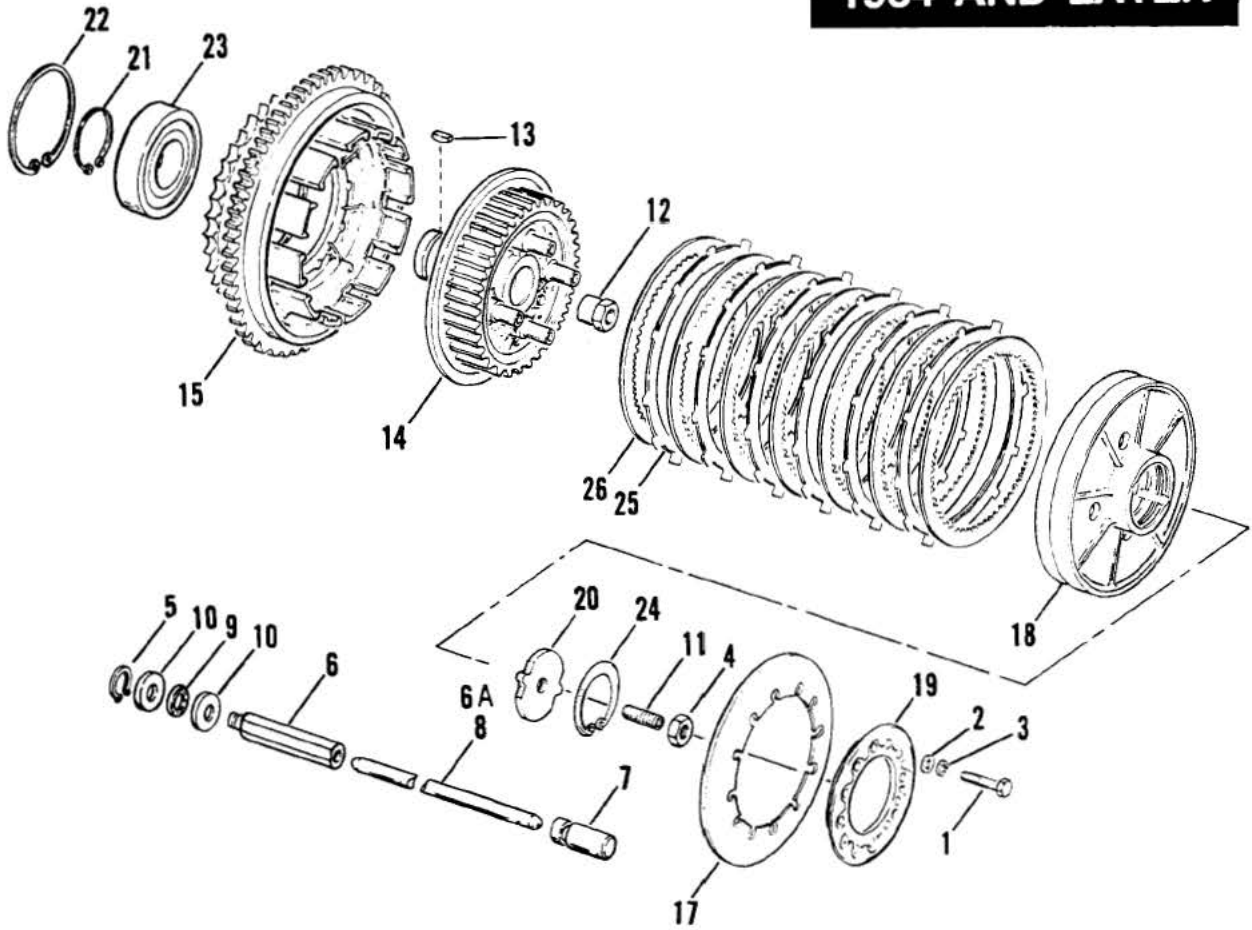

RETAIL PRICE	INDEX NO.	PART NO.	NAME	USED ON
	1	2881W	BOLT (4)	Late 84 — FXST; 85 to * — All Models
	2	6099	WASHER (4)	Late 84 — FXST; 85 to * — All Models
	3	7036	LOCKWASHER (4)	Late 84 — FXST; 85 to * — All Models
	4	7848W	NUT	Late 84 — FXST; 85 to * — All Models
	5	11096	RETAINING RING	Late 84 — FXST; 85 to * — All Models
	6	37089—84	ROD END, clutch push rod	Late 84 — FXST; 85 to * — All Models
	6A	37088—85	PUSH ROD, clutch release	86 to * — FXST
	7	37090—84	ROD END, clutch push rod	Late 84 — FXST; 85 to * — All Models
	8	37285—84	PUSH ROD, clutch release	Late 84 — FXST; 85 to * — All Models
	9	37312—75	BEARING, push rod	Late 84 — FXST; 85 to * — All Models
	10	37313—80	THRUST WASHER, inner (2)	Late 84 — FXST; 85 to * — All Models
	11	37357—84	ADJUSTING STUD, push rod	Late 84 — FXST; 85 to * — All Models
	12	37496—84	NUT, mainshaft (clutch side)	Late 84 — FXST; 85 to * — All Models
	13	37523—15A	KEY, clutch	Late 84 — FXST
		37523—85	KEY, clutch	85 to * — All Models
	14	37550—84	CLUTCH HUB, inner	Late 84 — FXST; 85 to * — All Models
	15	37702—84	CLUTCH SHELL AND SPROCKET, with starter ring gear	Late 84 & 85 — FXST; 85 — FXEF
		37707—84	CLUTCH SHELL AND SPROCKET, with starter ring gear	85 to * — FXWG, FXSB; 86 to * — FXST
	17	37871—84	DIAPHRAGM SPRING PLATE	Late 84 — FXST; 85 to * — All Models
	18	37901—84	PRESSURE PLATE	Late 84 — FXST; 85 to * — All Models
	19	37902—86	ADJUSTER PLATE	Late 84 to * — FXST; 85 to * — All Models
	20	37903—84	RELEASE PLATE, center	Late 84 — FXST; 85 to * — All Models
	21	37094—84	RETAINING RING, external — bearing	Late 84 — FXST; 85 to * — All Models
	22	37905—84	RETAINING RING, internal — bearing	Late 84 — FXST; 85 to * — All Models
	23	37906—84	BEARING, clutch assembly	Late 84 — FXST; 85 to * — All Models
	24	37907—84	RETAINING RING, pressure plate	Late 84 — FXST; 85 to * — All Models
	25	37931—84	FRICTION DISC (6)	Late 84 — FXST; 85 to * — All Models
	26	37975—84	DRIVE DISC (7)	Late 84 — FXST; 85 to * — All Models

# CLUTCH HAND CONTROL

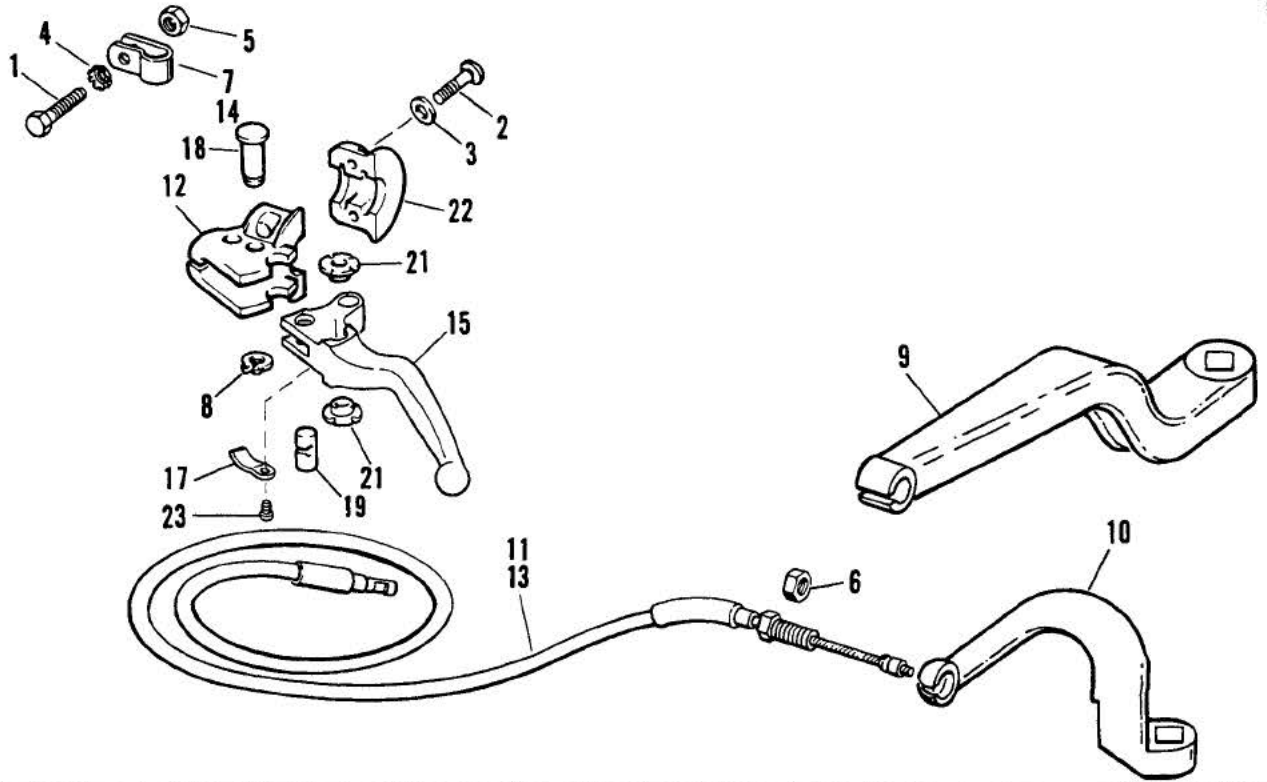

# CLUTCH HAND CONTROL

FX18

RETAIL PRICE	INDEX NO.	PART NO.	NAME	USED ON
	1	2585	SCREW	85 to * — All Models
		3491	BOLT	84 — FXST; 85 to * — All Models
	2	4015	SCREW (2)	84 — FXST; 85 to * — All Models
	3	6099	WASHER (2)	84 — FXST; 85 to * — All Models
	4	7115	LOCKWASHER	85 to * — All Models
		7143	LOCKWASHER	84 — FXST; 85 to * — All Models
	5	7608	NUT	84 — FXST; 85 to * — All Models
	6	7800W	NUT	84 — FXST
		7851W	NUT	85 to * — All Models
	7	10059	CLAMP, clutch cable	84 — FXST; 85 to * — All Models
	8	11143	RETAINING RING	84 — FXST; 85 to * — All Models
	9	37054—79A	RELEASE LEVER, clutch	84 — FXST; 85 — All Models; 86 to * — FXWG
	10	37096—85	RELEASE LEVER, clutch	86 to * — FXST
	11	38605—86	CABLE ASSEMBLY	86 to * — FXST
	12	38608—82B	BRACKET, hand lever (black)	84 — FXST; 85 to * — All Models
	13	38618—68C	CABLE ASSEMBLY	84 — FXST; 85 — All Models; 86 to * — FXWG
	14	38712—68	BRACKET, clutch cable	85 to * — All Models
	15	45017—82A	HAND LEVER, only	84 — FXST; 85 to * — All Models
	17	45021—86	SPRING, anti-rattle	86 to * — FXST, FXWG
	18	45032—82	PIN, hand lever pivot	84 — FXST; 85 to * — All Models
	19	45036—82	CABLE ANCHOR PIN, hand lever	84 — FXST; 85 to * — All Models
	21	45039—68	BUSHING, hand lever cable anchor pin (plastic) (2)	84 — FXST; 85 to * — All Models
	22	45044—82	CLAMP, lever bracket	84 — FXST; 85 to * — All Models
	23	90770—79	SCREW	86 to * — FXST, FXWG

# CHAINS, BELTS AND SPROCKETS

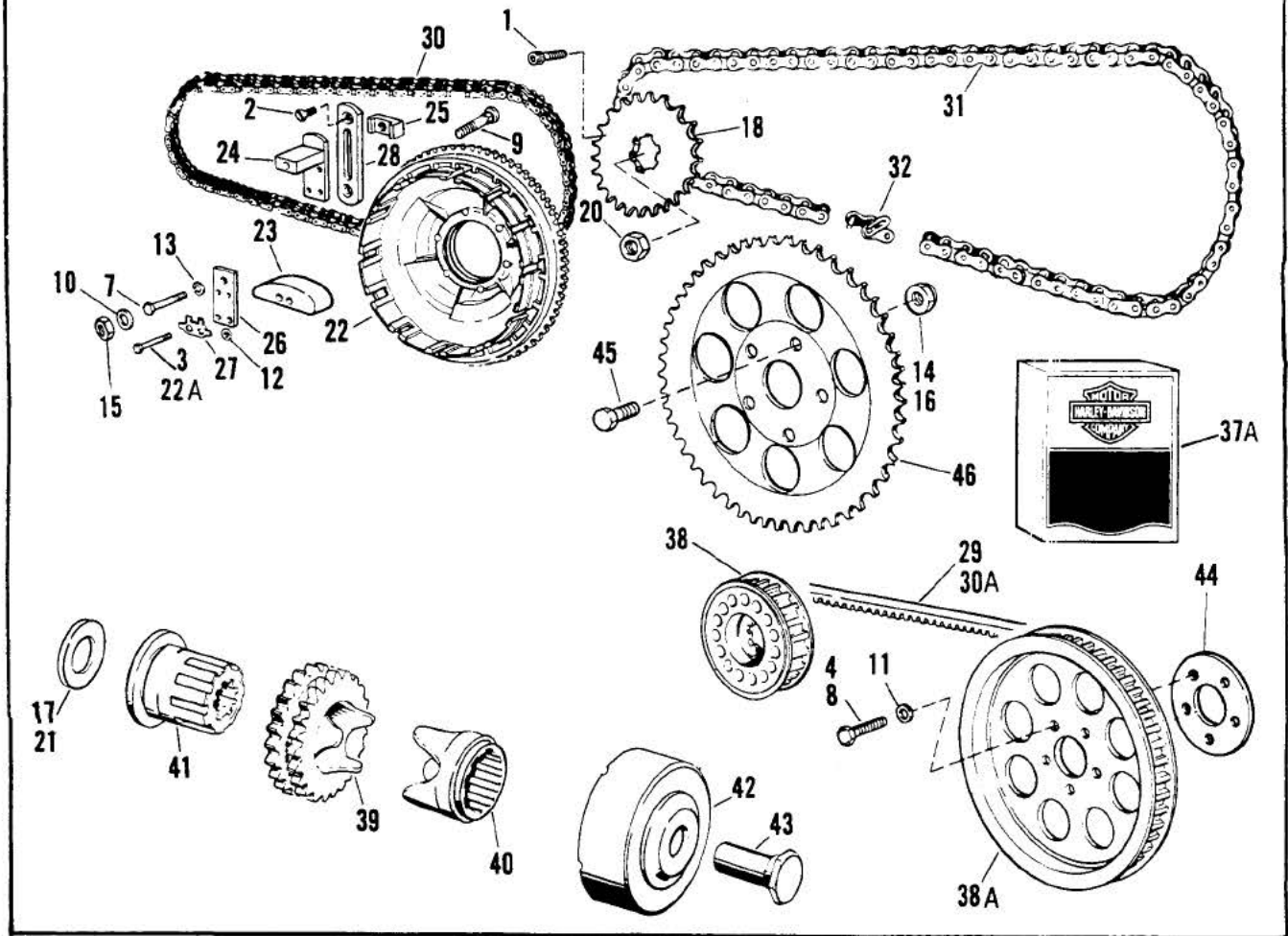

## CHAINS, BELTS AND SPROCKETS

FX19-1

RETAIL PRICE	INDEX NO.	PART NO.	NAME	USED ON
	1	857	SCREW, mainshaft sprocket	84 - FXST; 85 to * - All Models
	2	1783	SCREW (2)	84 - FXST; 85 to * - All Models
	3	2614	BOLT (2)	85 to * - All Models
	4	3771	BOLT (5)	85 - FXSB
		3782	BOLT (5)	85 - FXEF
	7	4401W	BOLT	84 - FXST
	8	4726	BOLT (5)	85 to * - FXWG; 86 to * - FXST
	9	5444	BOLT	85 to * - All Models
	10	6400HB	WASHER	85 to * - All Models
	11	6516HW	WASHER (5)	85 to * - FXSB, FXWG; 86 to * - FXST
	12	6703	WASHER (2)	85 to * - All Models
	13	7038	LOCKWASHER	84 - FXST
	14	7561	NUT (5)	85 to * - FXWG; 86 to * - FXST
	15	7778	LOCKNUT	85 to * - All Models
	16	7825	LOCKNUT (5)	84 & 85 - FXST
		7827W	LOCKNUT (5)	85 - FXEF

# CHAINS, BELTS AND SPROCKETS (CONT'D)

FX19-2

RETAIL PRICE	INDEX NO.	PART NO.	NAME	USED ON
	17	24032-70	SPACER, sprocket shaft — 0.06 thick	84 — FXST; 85 to * — All Models
		24033-70	SPACER, sprocket shaft — 0.09 thick	84 — FXST; 85 to * — All Models
		24034-70	SPACER, sprocket shaft — 0.12 thick	84 — FXST; 85 to * — All Models
		24035-70	SPACER, sprocket shaft — 0.15 thick	84 — FXST; 85 to * — All Models
		24036-70	SPACER, sprocket shaft — 0.18 thick	84 — FXST; 85 to * — All Models
		24037-70	SPACER, sprocket shaft — 0.21 thick	84 — FXST; 85 to * — All Models
	18	33337-83	SPROCKET KIT, mainshaft — 23 T	84 & 85 — FXST; 85 — FXEF
	19	33341-83	SPROCKET KIT, transmission — belt	85 & 86 — FXWG, FXSB
	20	35211-36	LOCKNUT, mainshaft sprocket	84 — FXST; 85 to * — All Models
	21	35850-84	SPACER, sprocket shaft — 0.01 thick (as req'd)	84 — FXST; 85 to * — All Models
		35851-84	SPACER, sprocket shaft — 0.02 thick (as req'd)	84 — FXST; 85 to * — All Models
		35852-84	SPACER, sprocket shaft — 0.03 thick (as req'd)	84 — FXST; 85 to * — All Models
	22	37702-70A	CLUTCH SHELL AND SPROCKET, with starter ring gear	Early 84 — FXST
		37702-84	CLUTCH SHELL AND SPROCKET,with starter ring gear	Late 84 & 85 — FXST; 85 — FXEF
		37707-84	CLUTCH SHELL AND SPROCKET, with starter ring gear	85 to * — FXWG, FXSB
	22A	39974-84	BOLT (2)	85 to * — All Models
	23	39976-65B	PAD, chain tensioner	84 — FXST; 85 to * — All Models
	24	39990-65	CHAIN TENSIONER SHOE	84 — FXST; 85 to * — All Models
	25	39992-65A	NUT, chain tensioner	84 — FXST
		39992-65C	CHAIN TENSIONER MTG. KIT, includes items 9, 10 & 14	84 — FXST; 85 to * — All Models
	26	39993-65	PLATE, chain tensioner	84 — FXST; 85 to * — All Models
	27	39996-65	LOCKWASHER, chain tensioner plate	84 — FXST; 85 to * — All Models
	28	39998-65	ANCHOR PLATE, chain tensioner	84 — FXST; 85 to * — All Models
	29	40003-79	BELT, rear drive	85 to * — FXWG, FXSB
	30	40007-36A	PRIMARY CHAIN	84 — FXST; 85 to * — All Models
	30A	40023-86	BELT, rear drive	86 to * — FXST
	31	40028-15E	REAR CHAIN (Duckworth)	84 & 85 — FXST; 85 — FXEF
		40029-15E	REAR CHAIN (Diamond)	84 & 85 — FXST; 85 — FXEF
	32	40026-77	CONNECTING LINK, rear chain (Diamond)	84 — FXST; 85 — FXEF
		40052-65	CONNECTING LINK, rear chain (Diamond)(press fit)	84 & 85 — FXST; 85 — FXEF
		40053-15	CONNECTING LINK, rear chain (Diamond)(slip fit)	84 & 85 — FXST; 85 — FXEF
		40053-65	CONNECTING LINK, rear chain (Duckworth)(slip fit)	84 & 85 — FXST; 85 — FXEF
	37A	40101-80	REPAIR KIT, belt drive	85 to * — FXWG, FXSB
	38	40210-85A	SPROCKET, belt	86 to * — FXST
		40212-80C	SPROCKET, belt	85 to * — FXWG, FXSB
	38A	40221-85A	SPROCKET, rear wheel — belt drive	85 to * — FXWG, FXSB; 86 to * — FXST
	39	40275-83	COMPENSATING SPROCKET — 24 T	84 — FXST; 85 to * — All Models
	40	40299-83	SLIDING CAM	84 — FXST; 85 to * — All Models
	41	40375-70	SHAFT EXTENSION	84 — FXST; 85 to * — All Models
	42	40384-83	RETAINER & COVER ASSEMBLY, w/spring washers	Early 84 — FXST
		40384-83A	RETAINER & COVER ASSEMBLY, w/spring washers	Late 84 — FXST; 85 to * — All Models
	43	40392-70	NUT	84 — FXST; 85 to * — All Models
	44	40932-81	SPACER, belt sprocket	85 to * — FXWG, FXSB
	45	41197-73	BOLT, rear sprocket (5)	84 & 85 — FXST
	46	41470-73A	SPROCKET, rear wheel (shot blast and chrome)	84 & 85 — FXST; 85 — FXEF

# FRONT BRAKE CONTROL

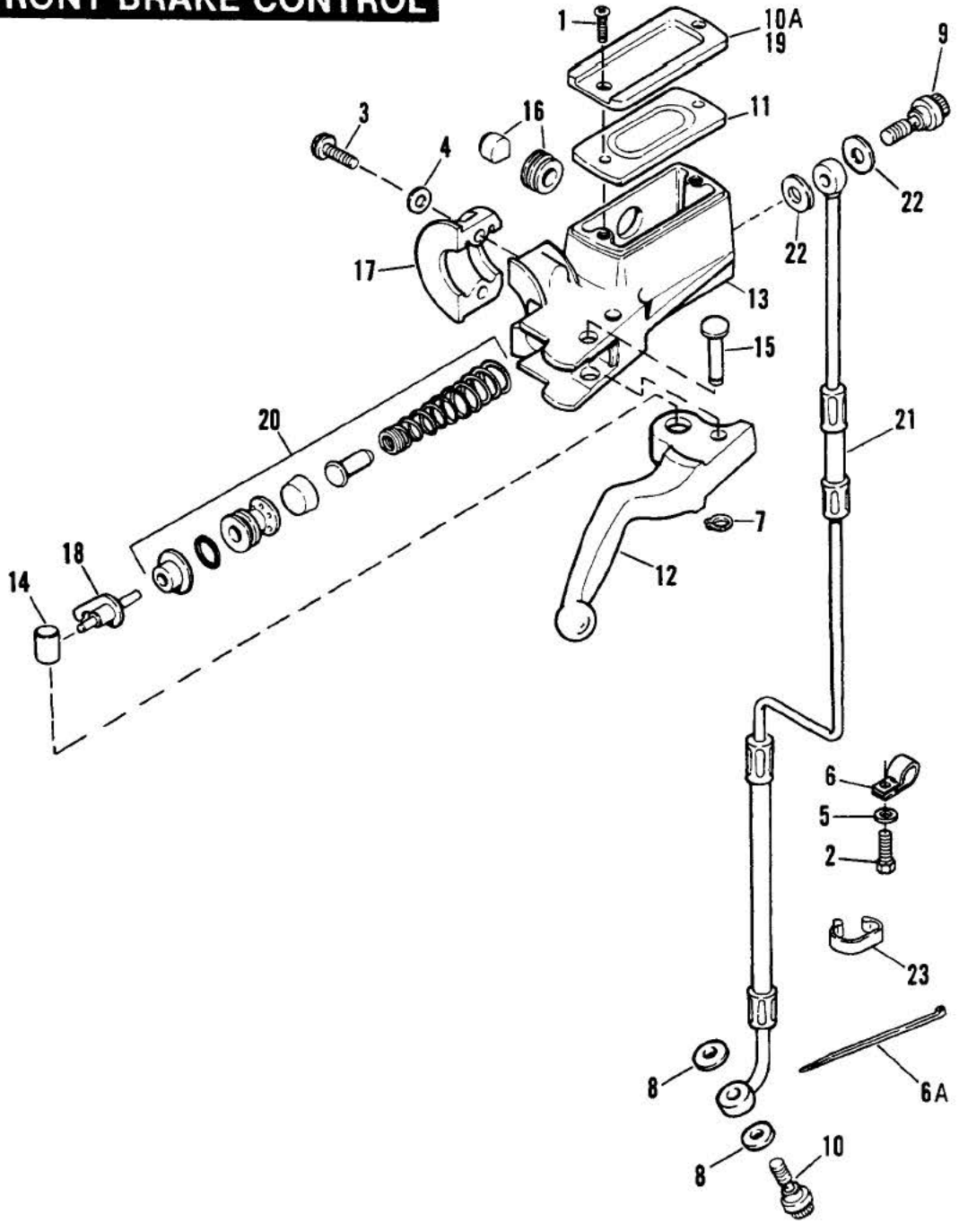

# FRONT BRAKE CONTROL

FX20

RETAIL PRICE	INDEX NO.	PART NO.	NAME	USED ON
	1	2579	SCREW (2)	84 — FXST; 85 to * — All Models
	2	2662W	SCREW	85 to * — FXWG, FXST
		3444	SCREW	84 — FXST; 85 to * — All Models
	3	4015	SCREW (2)	84 — FXST; 85 to * — All Models
	4	6099	WASHER (2)	84 — FXST; 85 to * — All Models
	5	6703	WASHER	84 — FXST; 85 to * — All Models
		7220	WASHER	85 to * — FXWG, FXST
	6	10031	CLAMP, front brake line	85 to * — FXWG, FXST
		10053	CLAMP, front brake line	84 — FXST; 85 to * — All Models
	6A	10081	CABLE STRAP (2)	Late 85 to * — All Models
	7	11143	RETAINING RING, external	84 — FXST; 85 to * — All Models
	8	41731—82	GASKET, brake line (2)	84 — FXST; 85 to * — All Models
	9	41739—84A	BOLT, front brake line	84 — FXST; 85 to * — All Models
	10	41747—82A	BOLT	84 — FXST; 85 to * — All Models
	10A	45004—85	COVER, master cylinder	Late 85 to * — All Models
	11	45005—85	GASKET, master cylinder cover	Late 85 to * — All Models
		45012—82	GASKET, master cylinder cover	84 — FXST; Early 85 — All Models
	12	45016—82	HAND LEVER, front brake	84 — FXST; 85 to * — All Models
	13	45019—84	MASTER CYLINDER ASSEMBLY, with hand lever	84 — FXST; Early 85 — All Models
	14	45031—82	PIN, stoplight switch & pushrod	84 — FXST; 85 to * — All Models
	15	45032—82	PIN, hand lever pivot	84 — FXST; 85 to * — All Models
	16	45042—82	FLUID LEVEL WINDOW KIT	84 — FXST; 85 to * — All Models
	17	45044—82	CLAMP, master cylinder	84 — FXST; 85 to * — All Models
	18	45051—82	STOPLIGHT SWITCH, with pushrod	84 — FXST; 85 to * — All Models
	19	45057—82	COVER, master cylinder	84 — FXST; Early 85 — All Models
	20	45072—87	REPAIR KIT, master cylinder	84 — FXST; 85 to * — All Models
	21	45112—84A	HOSE, front brake	84 — FXST
		45113—84	HOSE, front brake	85 to * — FXWG
		45121—88	HOSE, front brake	85 — FXEF
		45124—84	HOSE, front brake	85 — FXSB
	22	45583—83	GASKET, front brake line (2)	84 — FXST; 85 to * — All Models
	23	67239—83	GUIDE, front brake hose (2)	84 — FXST; Early 85 — All Models



# FRONT BRAKE CALIPER

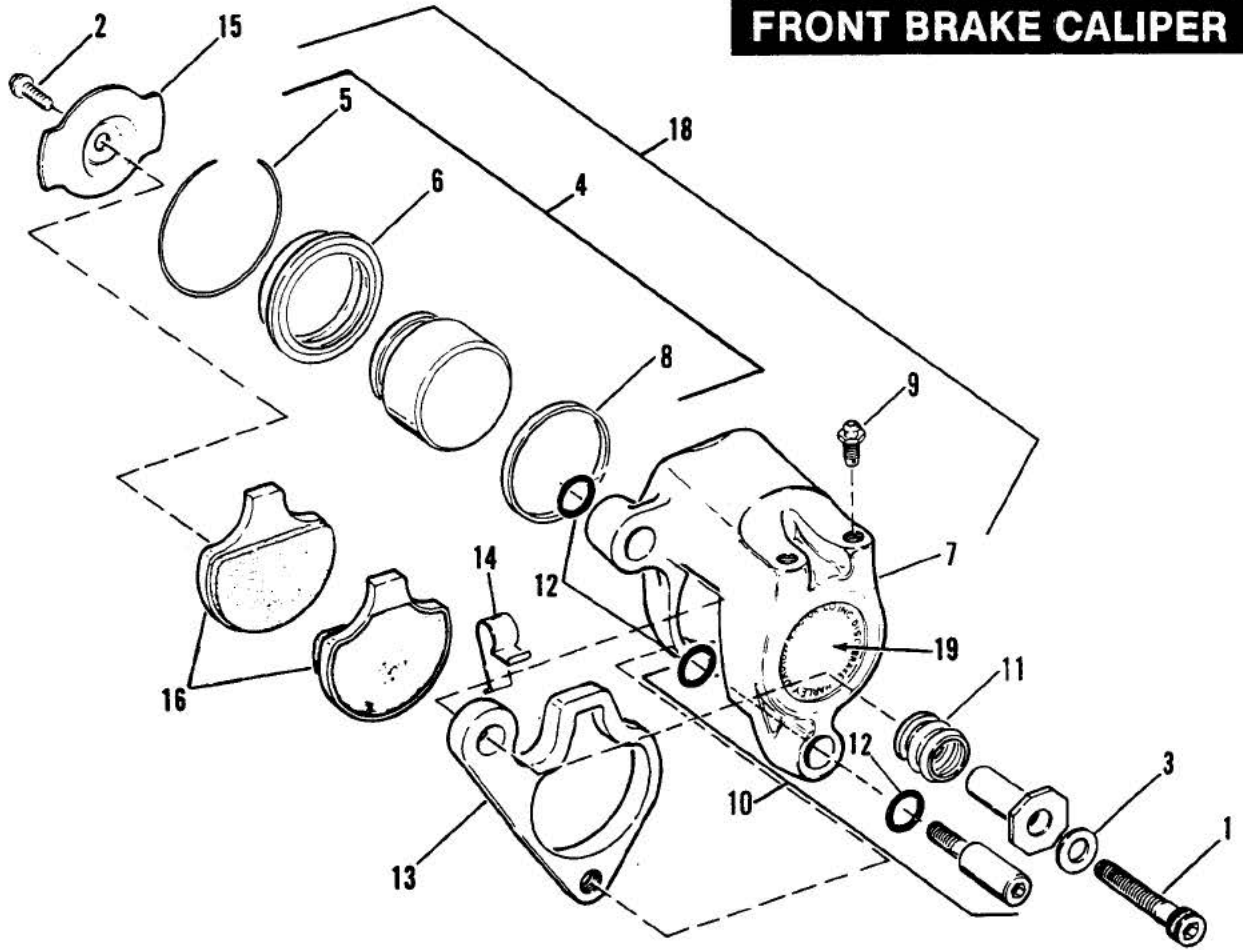

# FRONT BRAKE CALIPER

FX21

RETAIL PRICE	INDEX NO.	PART NO.	NAME	USED ON
	1	855A	SCREW .....	84 — FXST; 85 to * — All Models
	2	3517	SCREW .....	84 — FXST; 85 to * — All Models
	3	6019	WASHER .....	84 — FXST; 85 to * — All Models
	4	44020—83	PISTON REBUILD KIT, includes items 5, 6 & 8 .....	84 — FXST; 85 to * — All Models
	5	44021—83	RETAINING RING, piston .....	84 — FXST; 85 to * — All Models
	6	44022—83	DUST BOOT, piston .....	84 — FXST; 85 to * — All Models
	7	44046—84	CALIPER REBUILD KIT, includes items 10 & 13 - 16 ...	84 — FXST; 85 to * — All Models
	8	44047—83	SEAL, piston .....	84 — FXST; 85 to * — All Models
	9	44048—83	BLEEDER FITTING .....	84 — FXST; 85 to * — All Models
	10	44053—83A	GUIDE PIN KIT, includes items 10 & 12 .....	84 — FXST; 85 to * — All Models
	11	44054—83	PIN BOOT .....	84 — FXST; 85 to * — All Models
	12	44059—83	O-RING (3) .....	84 — FXST; 85 to * — All Models
	13	44060—83	BRACKET, caliper mounting .....	84 — FXST; 85 to * — All Models
	14	44061—83	SPRING CLIP .....	84 — FXST; 85 to * — All Models
	15	44062—83	RETAINING PAD .....	84 — FXST; 85 to * — All Models
	16	44063—83A	PAD SET .....	84 — FXST; 85 to * — All Models
	18	44065—83	CALIPER ASSEMBLY, left .....	N/A 84 — FXST; 85 to * — All Models
	19	44197—77	LABEL, front brake caliper .....	84 — FXST; 85 to * — All Models

# REAR BRAKE CONTROL — FXWG, FXST

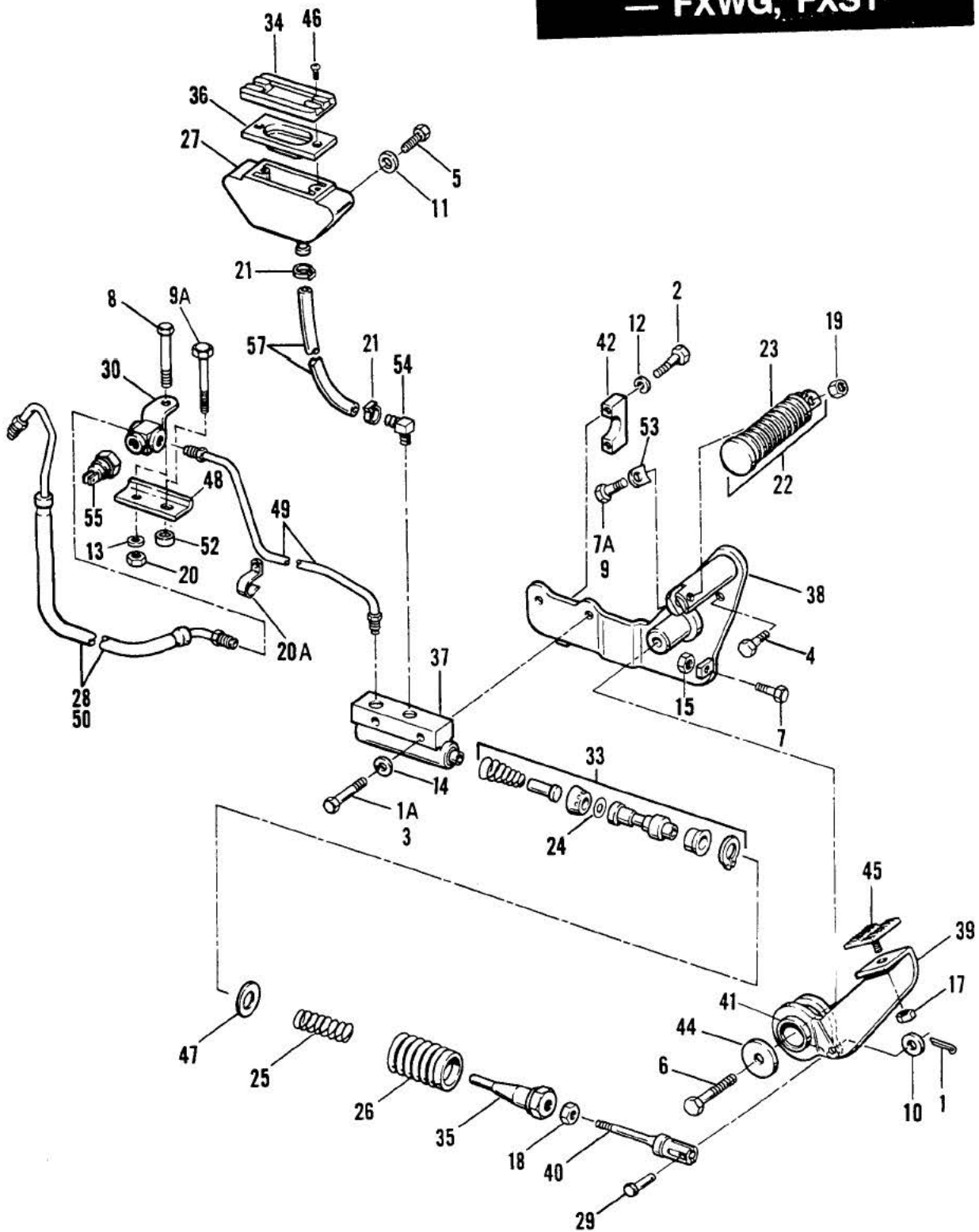

RETAIL PRICE	INDEX NO.	PART NO.	NAME	USED ON
	1	515	COTTER PIN	84 to * — FXST; 85 to * — FXWG
	1A	2667	BOLT (2)	86 to * — FXST
	2	2872W	BOLT (2)	84 — FXST; 85 to * — FXWG
	3	2887W	BOLT (2)	84 — FXST; 85 to * — FXWG
	4	3464	BOLT	84 to * — FXST; 85 to * — FXWG
	5	3473	BOLT (2)	84 to * — FXST; 85 to * — FXWG
	6	3509	BOLT	84 to * — FXST; 85 to * — FXWG
	7	3825	BOLT	84 to * — FXST; 85 to * — FXWG
	7A	4337W	BOLT	86 to * — FXST
	8	4713W	BOLT	84 to * — FXST; 85 to * — FXWG
	9	4721	BOLT	84 & 85 — FXST; 85 to * — FXWG
	9A	4724	BOLT	86 to * — FXST
	10	6220W	WASHER	84 to * — FXST; 85 to * — FXWG
	11	6716	WASHER (2)	84, Late 85 to * — FXST
	12	7036	LOCKWASHER	84 — FXST
	13	7038	LOCKWASHER	84 to * — FXST; 85 to * — FXWG
	14	7127	LOCKWASHER (2)	84 to * — FXST; 85 to * — FXWG
	15	7683	LOCKNUT	84 to * — FXST; 85 to * — FXWG
	17	7742	LOCKNUT	84 to * — FXST; 85 to * — FXWG
	18	7744	JAMNUT	84 to * — FXST; 85 to * — FXWG
	19	7776W	LOCKNUT	86 to * — FXST
		7778	LOCKNUT	84 & 85 — FXST; 85 to * — FXWG
	20	7783	NUT	84 to * — FXST; 85 to * — FXWG
	20A	10033	CLAMP, brake hose	84 to * — FXST; 85 to * — FXWG
		10036	CLAMP, rear brake hose	85 to * — FXWG
	21	10038	CLAMP, reservoir hose (2)	84 to * — FXST; 85 to * — FXWG
	22	33048—72	FOOTREST	84 to * — FXST; 85 to * — FXWG
	23	33189—63	RUBBER COVER, footrest	84 to * — FXST; 85 to * — FXWG
	24	40918—82	WASHER, piston cup	84 to * — FXST; 85 to * — FXWG
	25	40920—82	SPRING, brake return	84 to * — FXST; 85 to * — FXWG
	26	40922—79	BOOT, push rod	84 to * — FXST; 85 to * — FXWG
	27	41800—81A	RESERVOIR, master cylinder	84 to * — FXST; 85 to * — FXWG
		41804—84A	RESERVOIR, master cylinder (HDI part only)	86 to * — FXST
	28	41033—82	REAR BRAKE HOSE	85 to * — FXWG
	29	42269—30	PIN, rear brake rod clevis	84 to * — FXST; 85 to * — FXWG
	30	42309—70	BRAKE LINE TEE	84 to * — FXST; 85 to * — FXWG
	33	42374—82B	REPAIR KIT, master cylinder	84 to * — FXST; 85 to * — FXWG
	34	42376—77A	COVER, master cylinder reservoir	84 to * — FXST; 85 to * — FXWG
	35	42448—82A	PLUNGER, master cylinder	84 to * — FXST; 85 to * — FXWG
	36	42455—80	GASKET, master cylinder reservoir	84 to * — FXST; 85 to * — FXWG
	37	42470—82B	MASTER CYLINDER	84 to * — FXST; 85 to * — FXWG
	38	42507—82	MOUNTING BRACKET (black wrinkle)	84 & 85 — FXST; 85 to * — FXWG
		42507—86	MOUNTING BRACKET	86 to * — FXST
	39	42515—82	LEVER, foot brake (chrome)	84 to * — FXST; 85 to * — FXWG
	40	42522—82	CLEVIS, brake rod	84 to * — FXST; 85 to * — FXWG
	41	42524—82	BUSHING (2)	84 to * — FXST; 85 to * — FXWG
	42	42526—82	SUPPORT BRACKET	84 — FXST; 85 to * — FXWG
	44	42531—82	WASHER	84 to * — FXST; 85 to * — FXWG
	45	42532—82	PAD, brake lever	84 to * — FXST; 85 to * — FXWG
	46	42534—82	SCREW (2)	84 to * — FXST; 85 to * — FXWG
	47	44126—82	WASHER, brake return spring	84 to * — FXST; 85 to * — FXWG
	48	45152—78A	BRACKET, brake line tee	84 to * — FXST; 85 to * — FXWG
	49	45154—84	REAR BRAKE TUBE	84 to * — FXST; 85 to * — FXWG
	50	45156—84	REAR BRAKE HOSE	84 to * — FXST
	52	47716—86	SPACER, brake tee	86 to * — FXST
	53	50912—72	SPRING WASHER, footrest	84 to * — FXST; 85 to * — FXWG
	54	63551—82	FITTING, 90° reservoir hose (brass)	84 to * — FXST; 85 to * — FXWG
	55	72023—51A	STOPLIGHT SWITCH, rear	84 to * — FXST; 85 to * — FXWG

NOTE: Hose is sold only in bulk length under the following part number. Cut to required length.

57	63573—82	HOSE, 5/16 rubber, 25 feet long	84 to * — FXST; 85 to * — FXWG
----	----------	---------------------------------	--------------------------------

# REAR BRAKE CONTROL — FXSB, FXEF

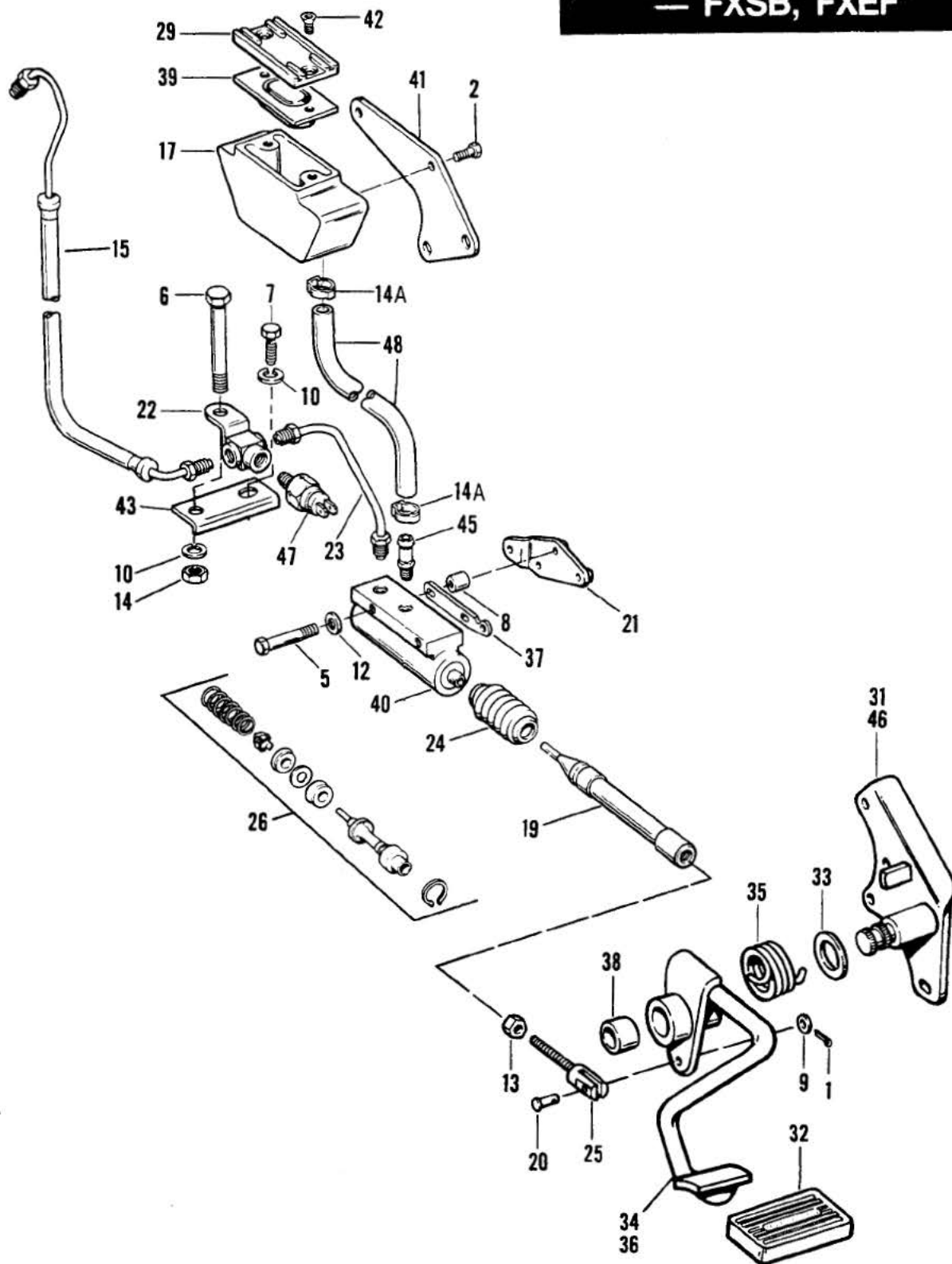

RETAIL PRICE	INDEX NO.	PART NO.	NAME	USED ON
	1	515	COTTER PIN .....	85 — FXSB, FXEF
	2	3473	BOLT (2) .....	85 — FXSB, FXEF
	5	4392	BOLT (2) .....	85 — FXSB, FXEF
	6	4713W	BOLT .....	85 — FXSB, FXEF
	7	4724	BOLT .....	85 — FXSB, FXEF
	8	5891	SPACER (2) .....	85 — FXSB, FXEF
	9	6220W	WASHER .....	85 — FXSB, FXEF
	10	7038	LOCKWASHER (2) .....	85 — FXSB, FXEF
	12	7127	LOCKWASHER (2) .....	85 — FXSB, FXEF
	13	7744	JAMNUT .....	85 — FXSB, FXEF
	14	7783	NUT .....	85 — FXSB, FXEF
	14A	10038	CLAMP, 19/32 reservoir hose (2) .....	85 — FXSB, FXEF
	15	41033—82	REAR BRAKE HOSE .....	85 — FXSB, FXEF
	17	41800—81A	RESERVOIR .....	85 — FXSB, FXEF
	19	42257—82	BRAKE ROD .....	85 — FXSB, FXEF
	20	42269—30	PIN, rear brake rod clevis .....	85 — FXSB, FXEF
	21	42299—82	SUPPORT BRACKET .....	85 — FXSB, FXEF
	22	42309—70	BRAKE LINE TEE .....	85 — FXSB, FXEF
	23	42320—82	REAR BRAKE TUBE .....	85 — FXSB, FXEF
	24	42326—82	RUBBER BOOT, master cylinder .....	85 — FXSB, FXEF
	25	42330—82	CLEVIS, brake rod .....	85 — FXSB, FXEF
	26	42374—82B	REPAIR KIT, master cylinder .....	85 — FXSB, FXEF
	29	42376—77A	COVER (reservoir) .....	85 — FXSB, FXEF
	31	42389—79	BRACKET, foot lever (polished chrome) .....	85 — FXSB
	32	42394—65	PAD, brake pedal .....	85 — FXSB, FXEF
	33	42396—79	WASHER, brake pedal pivot .....	85 — FXSB, FXEF
	34	42399—82	LEVER, foot brake .....	85 — FXEF
	35	42425—79	SPRING, foot lever .....	85 — FXSB, FXEF
	36	42428—82	LEVER, foot brake (polished chrome) .....	85 — FXSB
	37	42433—83	MOUNTING PLATE, master cylinder .....	85 — FXSB, FXEF
	38	42435—79	BUSHING, foot brake lever .....	85 — FXSB, FXEF
	39	42455—80	GASKET (reservoir cover) .....	85 — FXSB, FXEF
	40	42470—82B	MASTER CYLINDER .....	85 — FXSB, FXEF
	41	42527—82	MOUNTING BRACKET, reservoir .....	85 — FXSB, FXEF
	42	42534—82	SCREW (2) .....	85 — FXSB, FXEF
	43	45152—78A	BRACKET, brake line tee .....	85 — FXSB, FXEF
	45	63548—82	FITTING, hose to reservoir (brass) .....	85 — FXSB, FXEF
	46	50800—71B	BRACKET, foot lever (shot blast & chrome) .....	85 — FXEF
	47	72023—51A	STOPLIGHT SWITCH, rear .....	85 — FXSB, FXEF

# REAR BRAKE CALIPER

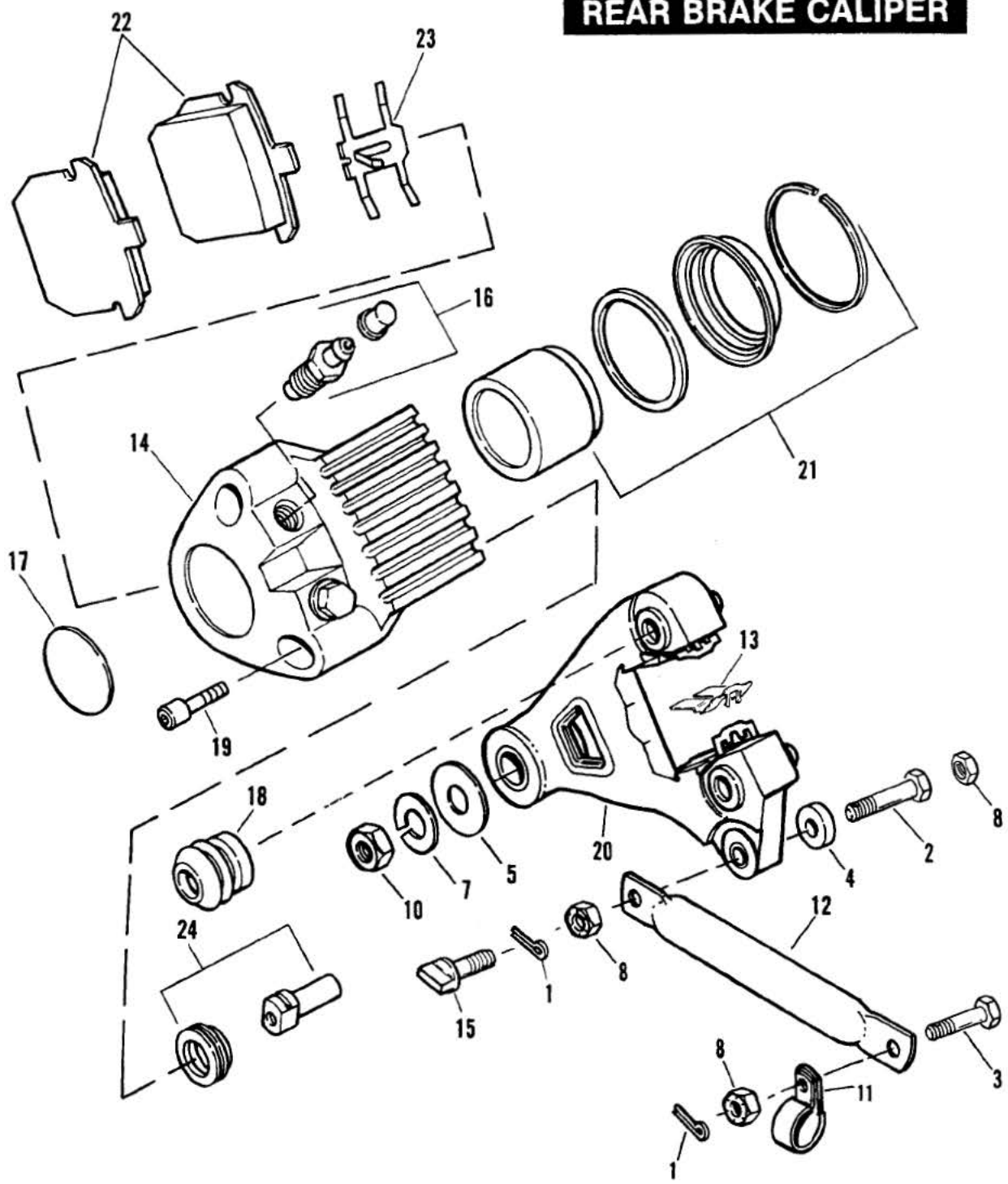

# REAR BRAKE CALIPER

FX23

RETAIL PRICE	INDEX NO.	PART NO.	NAME	USED ON
	1	513	COTTER PIN (2) .....	N/A 85 — FXWG, FXSB, FXEF
		553	COTTER PIN (2) .....	N/A 86 to * — FXWG
	2	3520	BOLT .....	85 to * — FXWG, FXSB, FXEF
	3	3525	BOLT .....	85 to * — FXWG, FXSB, FXEF
	4	6115	WASHER .....	84 to * — FXST; 85 to * — FXWG
	5	6655	WASHER .....	84 — FXST; 85 to * — All Models
	7	7022	LOCKWASHER .....	84 — FXST; 85 to * — All Models
	8	7628	NUT (2) .....	85 to * — FXWG, FXSB, FXEF
		7776W	LOCKNUT .....	84 to * — FXST
	10	7986	NUT .....	84 — FXST; 85 to * — All Models
	11	10036	STRAP, rear brake hose .....	85 — All Models; 86 to * — FXWG
	12	41039—82	ANCHOR ARM, rear fork (black) .....	85 to * — FXWG, FXSB, FXEF
	13	41665—82	ABUTMENT SHIM (2) .....	84 — FXST; 85 to * — All Models
	14	44050—82A	CALIPER BODY ASSEMBLY, includes items 16, 21 & 23	84 — FXST; 85 to * — All Models
	15	44069—84	PIN, mounting .....	84 to * — FXST
	16	44146—82	BLEED SCREW, with dust cover .....	84 — FXST; 85 to * — All Models
	17	44197—77	LABEL, rear brake caliper .....	84 — FXST; 85 to * — All Models
	18	44200—82	PIN BOOT (2) .....	84 — FXST; 85 to * — All Models
	19	44201—82	BOLT, mounting (2) .....	84 — FXST; 85 to * — All Models
	20	44207—82	MOUNTING BRACKET, includes items 13 & 24 .....	84 — FXST; 85 to * — All Models
	21	44208—82	REPAIR KIT, rear brake caliper .....	84 — FXST; 85 to * — All Models
	22	44209—82	PAD SET .....	84 — FXST; 85 to * — All Models
	23	44211—82	PAD SPRING .....	84 — FXST; 85 to * — All Models
	24	44212—82	GUIDE PIN KIT, includes items 18 & 19 .....	84 — FXST; 85 to * — All Models



# SPOKE WHEEL - FRONT — FXWG, FXEF, FXST

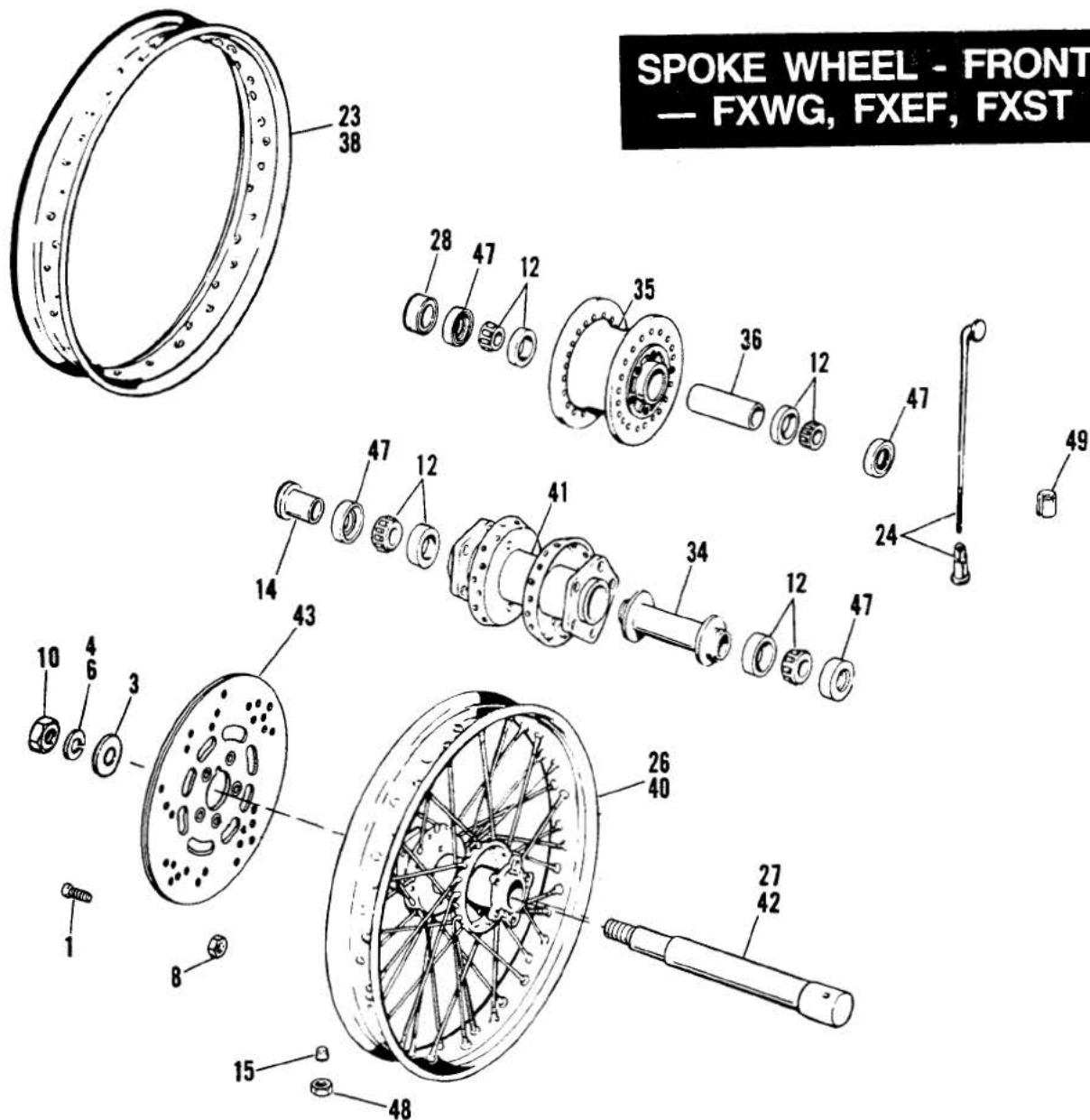

RETAIL PRICE	INDEX NO.	PART NO.	NAME	USED ON
	1	3655	SCREW (5)	84 to * — FXST; 85 to FXEF; 85 to * — FXWG
	3	6590HW	WASHER	84 to * — FXST; 85 to * — FXWG
		6653	WASHER	85 — FXEF
	4	7022	LOCKWASHER	85 — FXEF
	6	7068	LOCKWASHER, axle	84 to * — FXST; 85 to * — FXWG
	8	7739	LOCKNUT (5)	84 to * — FXST; 85 & 86 — FXWG
	10	7813	NUT	85 — FXEF
		7845	NUT	84 to * — FXST; 85 to * — FXWG
	12	9052	ROLLER BEARING (2)	84 to * — FXST; 85 to * — FXWG, FXEF
	14	40910—84A	SPACER, right bearing	84 to * — FXST; 85 to * — FXWG
	15	41123—79	VALVE CAP	84 to * — FXST; 85 to * — FXWG, FXEF
	23	43001—79	RIM, front wheel, 19"	85 — FXEF
	24	43024—73B	SPOKE AND NIPPLE, 19" rim — short (metric) (20)	85 — FXEF
		43025—73B	SPOKE AND NIPPLE, 19" rim — long (metric) (20)	85 — FXEF
		43041—85	SPOKE AND NIPPLE, 21" rim (40)	Late 86 to * — FXST
		43057—80A	SPOKE AND NIPPLE, 21" rim (40)	84 to Early 86 — FXST; 85 & 86 — FXWG
	26	43312—84	FRONT WHEEL ASSEMBLY, with hub assembly — 19"	85 — FXEF
	27	43346—83	AXLE	84 to * — FXST; 85 to * — FXWG
	28	43358—83	SPACER, bearing — right side	85 — FXEF
	34	43601—78A	SPACER, (with flanges) — 4.420 (orange)	84 to * — FXST; 85 to * — FXWG
		43602—78A	SPACER, (with flanges) — 4.434 (yellow)	84 to * — FXST; 85 to * — FXWG
		43603—78A	SPACER, (with flanges) — 4.448 (white)	84 to * — FXST; 85 to * — FXWG
	35	43619—84	HUB, with bearings, seals & spacers	85 — FXEF
	36	43623—78	SPACER, 2.564 (violet)	85 — FXEF
		43624—78	SPACER, 2.550 (pink)	85 — FXEF
		43625—78	SPACER, 2.536 (gold)	85 — FXEF
	38	43662—80B	RIM, front wheel, 21" (chrome)	84 to * — FXST; 85 to * — FXWG
	40	43671—84	FRONT WHEEL ASSEMBLY, with hub assembly — 21"	84 to * — FXST; 85 to * — FXWG
	41	43672—84	HUB, with bearings, seals & spacers	84 to * — FXST; 85 to * — FXWG
	42	43883—84	AXLE	85 — FXEF
	43	44136—84A	DISC, front brake	84 to * — FXST; 85 to * — FXWG, FXEF
	47	47519—83A	OIL SEAL (2)	84 to * — FXST; 85 to * — FXWG, FXEF
	48	54321—85	NUT, valve stem	Late 84 to * — FXST; 85 to * — FXWG
	49	95578—41	WHEEL WEIGHT, 1/2 oz. — 0.275" I.D. (round)	84 to * — FXST; 85 to * — FXWG, FXEF
		95581—47	WHEEL WEIGHT, 3/4 oz. — 0.275" I.D. (round)	84 to * — FXST; 85 to * — FXWG, FXEF
		95582—47	WHEEL WEIGHT, 1 oz. — 0.275" I.D. (round)	84 to * — FXST; 85 to * — FXWG, FXEF

**CAST WHEEL - FRONT**  
**— FXSB, FXEF**

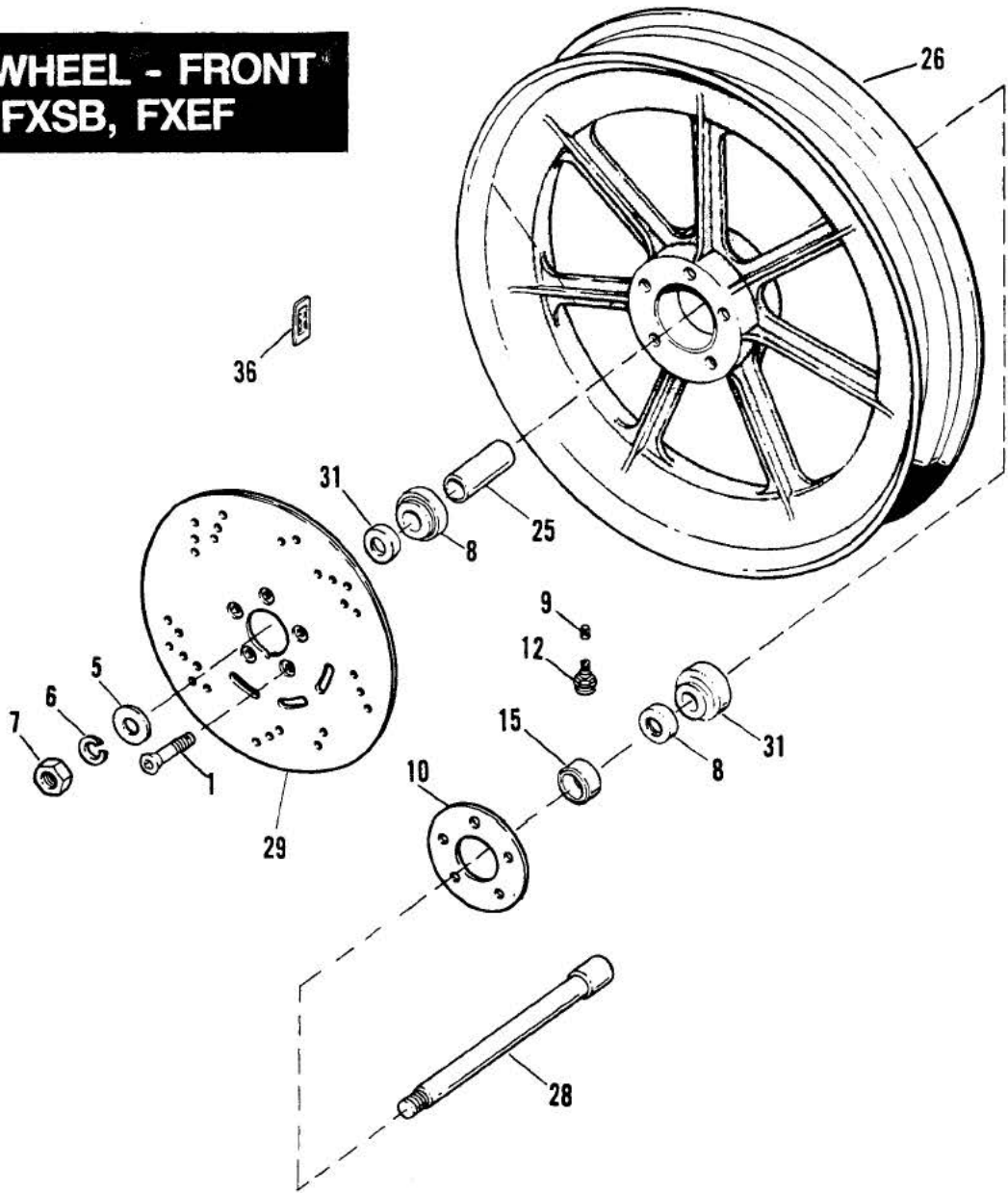

**CAST WHEEL — FRONT — FXSB, FXEF**

**FX24A**

RETAIL PRICE	INDEX NO.	PART NO.	NAME	USED ON
	1	3655	SCREW (10) .....	85 — FXSB, FXEF
	5	6653	WASHER .....	85 — FXSB, FXEF
	6	7022	LOCKWASHER .....	85 — FXSB, FXEF
	7	7813	NUT .....	85 — FXSB, FXEF
	8	9052	ROLLER BEARING (2) .....	85 — FXSB, FXEF
	9	41123—79	VALVE CAP .....	85 — FXSB, FXEF
	10	41814—76A	HUB PLATE .....	85 — FXSB, FXEF
	12	43150—83	VALVE STEM .....	85 — FXSB, FXEF
	15	43358—83	SPACER, bearing .....	85 — FXSB, FXEF
	25	43623—78	SPACER, between bearings — 2.564 (violet) .....	85 — FXSB, FXEF
		43624—78	SPACER, between bearings — 2.250 (pink) .....	85 — FXSB, FXEF
		43625—78	SPACER, between bearings — 2.536 (gold) .....	85 — FXSB, FXEF
	26	43626—84	WHEEL ASSEMBLY, 19" (black) .....	85 — FXSB, FXEF
	28	43883—84	FRONT AXLE .....	85 — FXSB, FXEF
	29	44136—84A	DISC, front brake .....	85 — FXSB, FXEF
	31	47519—83A	OIL SEAL (2) .....	85 — FXSB, FXEF
	36	95594—84	WHEEL WEIGHT, 1/4 oz. (black) .....	85 — FXSB, FXEF

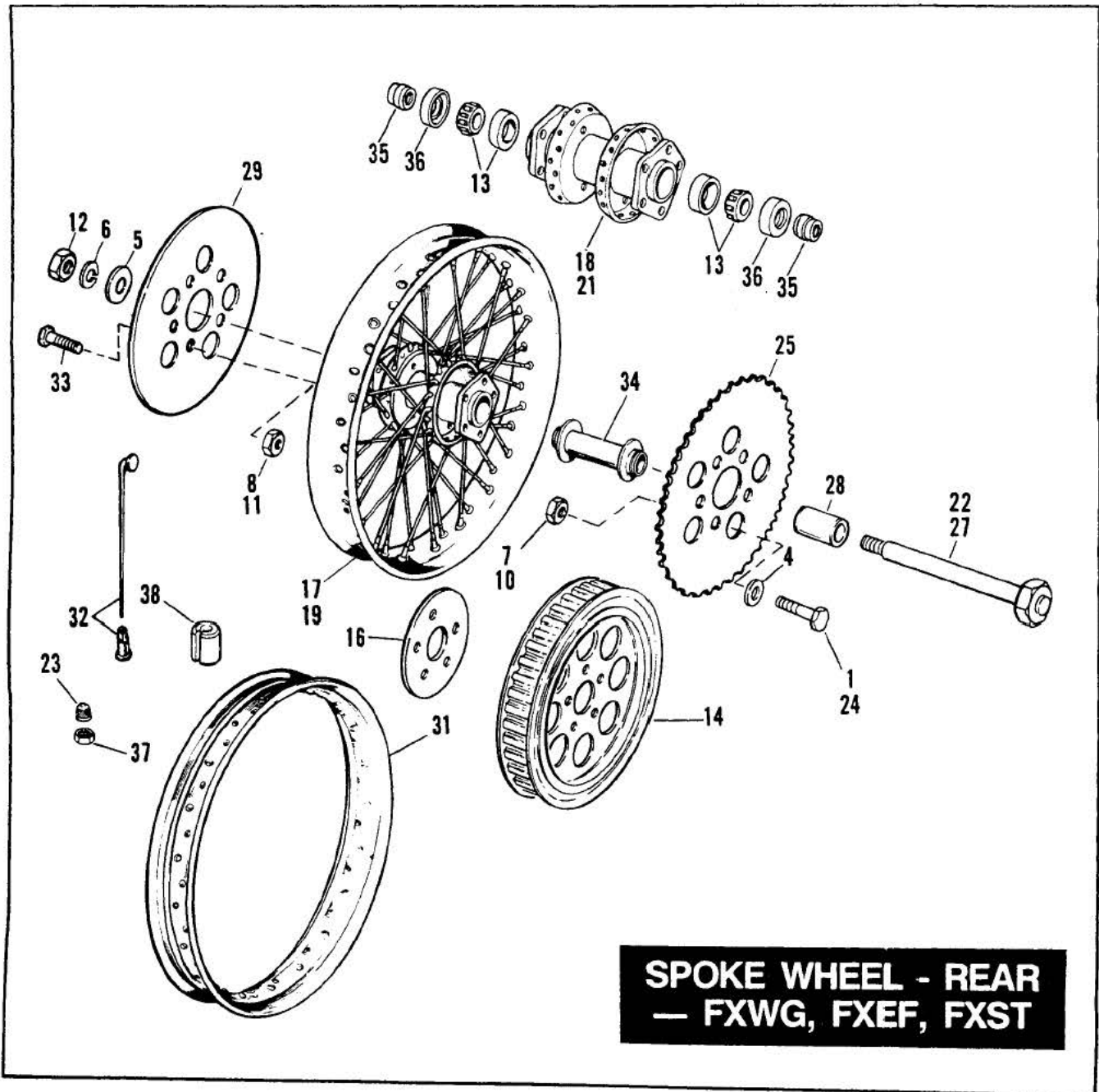

**SPOKE WHEEL - REAR  
— FXWG, FXEF, FXST**

**SPOKE WHEEL — REAR — FXWG, FXEF, FXST**

**FX25**

RETAIL PRICE	INDEX NO.	PART NO.	NAME	USED ON
	1	3782	BOLT (5)	85 to * — FXEF; Late 85 to * — FXST
		4726	BOLT (5)	85 to * — FXWG; 86 to * — FXST
	4	6516HW	WASHER (5)	85 to * — FXWG; 86 to * — FXST
	5	6655	WASHER	84 to * — FXST; 85 to * — FXWG, FXEF
	6	7022	LOCKWASHER	84 to * — FXST; 85 to * — FXWG, FXEF
	7	7561	NUT (5)	85 to * — FXWG; 86 to * — FXST
	8	7778	LOCKNUT (5)	85 to * — FXWG, FXEF, FXST
		7783	NUT (5)	84 — FXST
	10	7825	LOCKNUT (5)	Early 85 — FXST
	11	7827W	LOCKNUT (5)	85 — FXEF; Late 85 — FXST
	12	7986	NUT	84 to * — FXST; 85 to * — FXWG, FXEF
	13	9052	ROLLER BEARING (2)	84 to * — FXST; 85 to * — FXWG, FXEF
	14	40221—85A	SPROCKET, belt drive	85 to * — FXWG; 86 to * — FXST
	16	40932—81	SPACER, belt sprocket	85 to * — FXWG
	17	40951—82	WHEEL ASSEMBLY, 16" (chrome)	84 & 85 — FXST; 85 to * — FXWG, FXEF
	18	40952—82A	WHEEL HUB, complete	84 & 85 — FXST; 85 to * — FXWG, FXEF
	19	40975—86	WHEEL ASSEMBLY, 16"	86 to * — FXST
	21	40976—86	WHEEL HUB, complete	86 to * — FXST
	22	41110—79A	AXLE	86 to * — FXST
	23	41123—79	VALVE CAP	84 to * — FXST; 85 to * — FXEF; 86 to * — FXWG
	24	41197—73	BOLT, rear sprocket (5)	84 & Early 85 — FXST
	25	41470—73A	SPROCKET, rear wheel (51 T.)	84 & 85 — FXST; 85 — FXEF
	27	41552—73	AXLE	84 & 85 — FXST; 85 — FXEF
		41580—79	AXLE	85 to * — FXWG
	28	41592—79	SPACER, rear axle	85 to * — FXWG
		41595—73	SPACER, rear axle — left	84 & 85 — FXST; 85 — FXEF
		41595—86	SPACER, rear axle — left	86 to * — FXST
	29	41791—79A	DISC, brake	84 to * — FXST; 85 to * — FXWG, FXEF
	31	43085—81	RIM, 16" (chrome)	84 to * — FXST; 85 to * — FXWG, FXEF
	32	43041—85	SPOKE AND NIPPLE, 16" rim (40)	Late 86 to * — FXST
		43032—40B	SPOKE AND NIPPLE, 16" rim — metric (40)	84 to Early 86 — FXST; 85 & 86 — FXWG, FXEF
	33	43567—79	SCREW (5)	84 to * — FXST; 85 to * — FXWG, FXEF
	34	43601—78A	SPACER, between bearings (w/flanges), 4.420 (orange)	84 to * — FXST; 85 to * — FXWG, FXEF
		43602—78A	SPACER, between bearings (w/flanges), 4.434 (yellow)	84 to * — FXST; 85 to * — FXWG, FXEF
		43603—78A	SPACER, between bearings (w/flanges), 4.448 (white)	84 to * — FXST; 85 to * — FXWG, FXEF
	35	43654—86A	SPACER, rear wheel (2)	84 to * — FXST; 85 to * — FXWG, FXEF
	36	47519—83A	OIL SEAL (2)	84 to * — FXST; 85 to * — FXWG, FXEF
	37	54321—85	NUT, valve stem	Late 84 to * — FXST; 85 to * — FXWG
	38	95578—41	WHEEL WEIGHT, 1/2 oz. — .275" I.D.	84 to * — FXST; 85 to * — FXWG, FXEF
		95581—47	WHEEL WEIGHT, 3/4 oz. — .275" I.D.	84 to * — FXST; 85 to * — FXWG, FXEF
		95582—47	WHEEL WEIGHT, 1 oz. — .275" I.D.	84 to * — FXST; 85 to * — FXWG, FXEF

**CAST WHEEL - REAR  
— FXSB, FXEF**

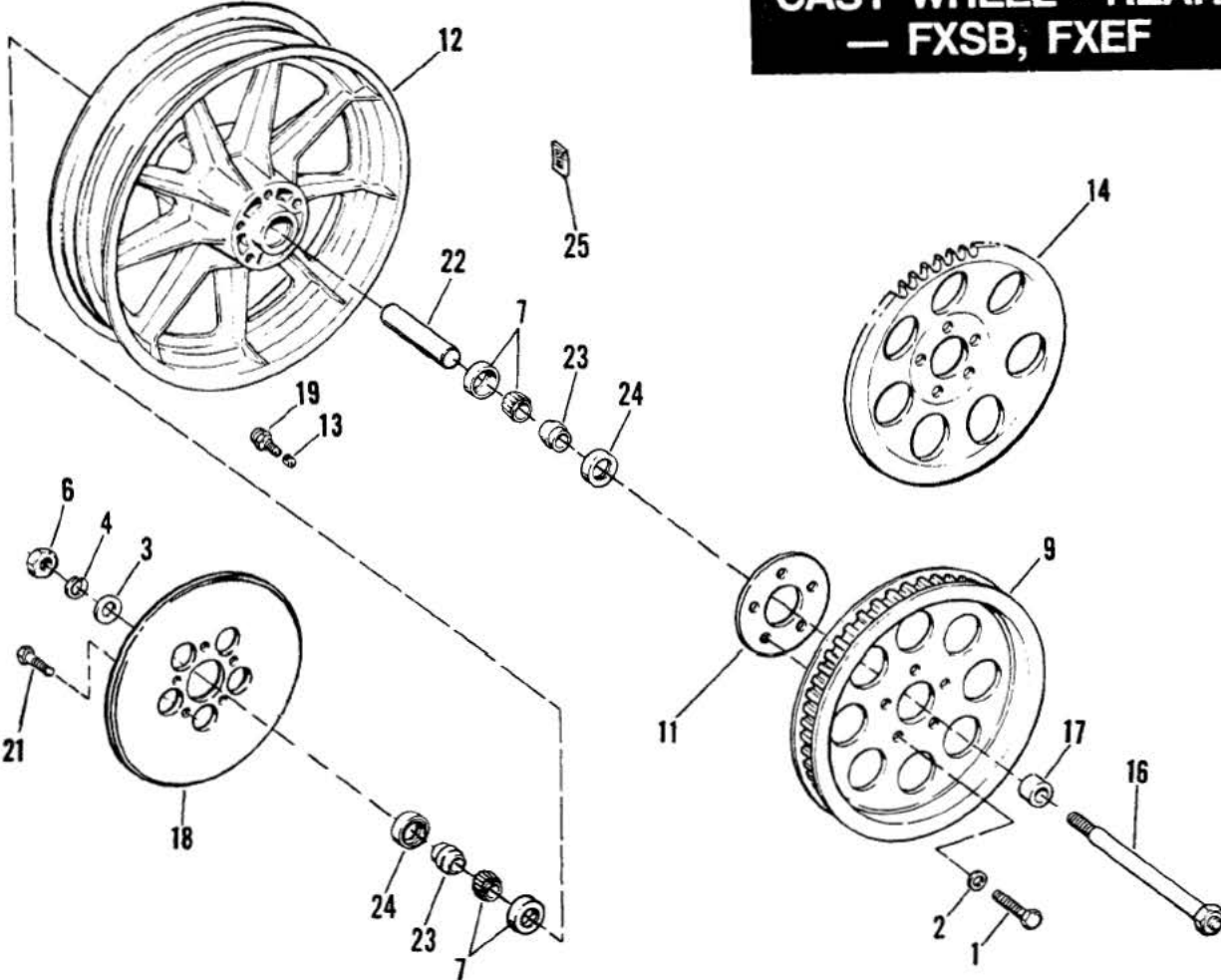

RETAIL PRICE	INDEX NO.	PART NO.	NAME	USED ON
	1	3771	BOLT (5)	85 — FXSB, FXEF
	2	6516HW	WASHER (5)	85 — FXSB, FXEF
	3	6655	WASHER	85 — FXSB
	4	7022	LOCKWASHER	85 — FXSB
	6	7986	NUT	85 — FXSB
	7	9052	ROLLER BEARING (2)	85 — FXSB, FXEF
	9	40221—85A	SPROCKET, belt drive	85 — FXSB
	11	40932—81	SPACER, belt sprocket	85 — FXSB
	12	41015—82A	WHEEL ASSEMBLY, cast aluminum, 16" (black)	85 — FXSB, FXEF
	13	41123—79	VALVE CAP	85 — FXSB, FXEF
	14	41470—73A	SPROCKET, rear wheel (51 T.)	85 — FXEF
	16	41552—73	AXLE	85 — FXEF
		41580—79	AXLE	85 — FXSB
	17	41592—79	SPACER, rear axle	85 — FXSB
	18	41791—79	DISC, brake	85 — FXSB, FXEF
	19	43157—83A	VALVE STEM	85 — FXSB, FXEF
	21	43567—79	SCREW, disc brake (5)	85 — FXSB, FXEF
	22	43604—78	SPACER, between bearing — 4.420 (orange) (as req'd.)	85 — FXSB, FXEF
		43605—78	SPACER, between bearing — 4.434 (yellow) (as req'd.)	85 — FXSB, FXEF
		43606—78	SPACER, between bearing — 4.448 (white) (as req'd.)	85 — FXSB, FXEF
	23	43654—86A	SPACER, rear wheel (2)	85 — FXSB, FXEF
	24	47519—83A	OIL SEAL (2)	85 — FXSB, FXEF
	25	95594—84	WHEEL WEIGHT, 0.25 oz. (black)	85 — FXSB, FXEF



# FRONT FORK — FXWG, FXST

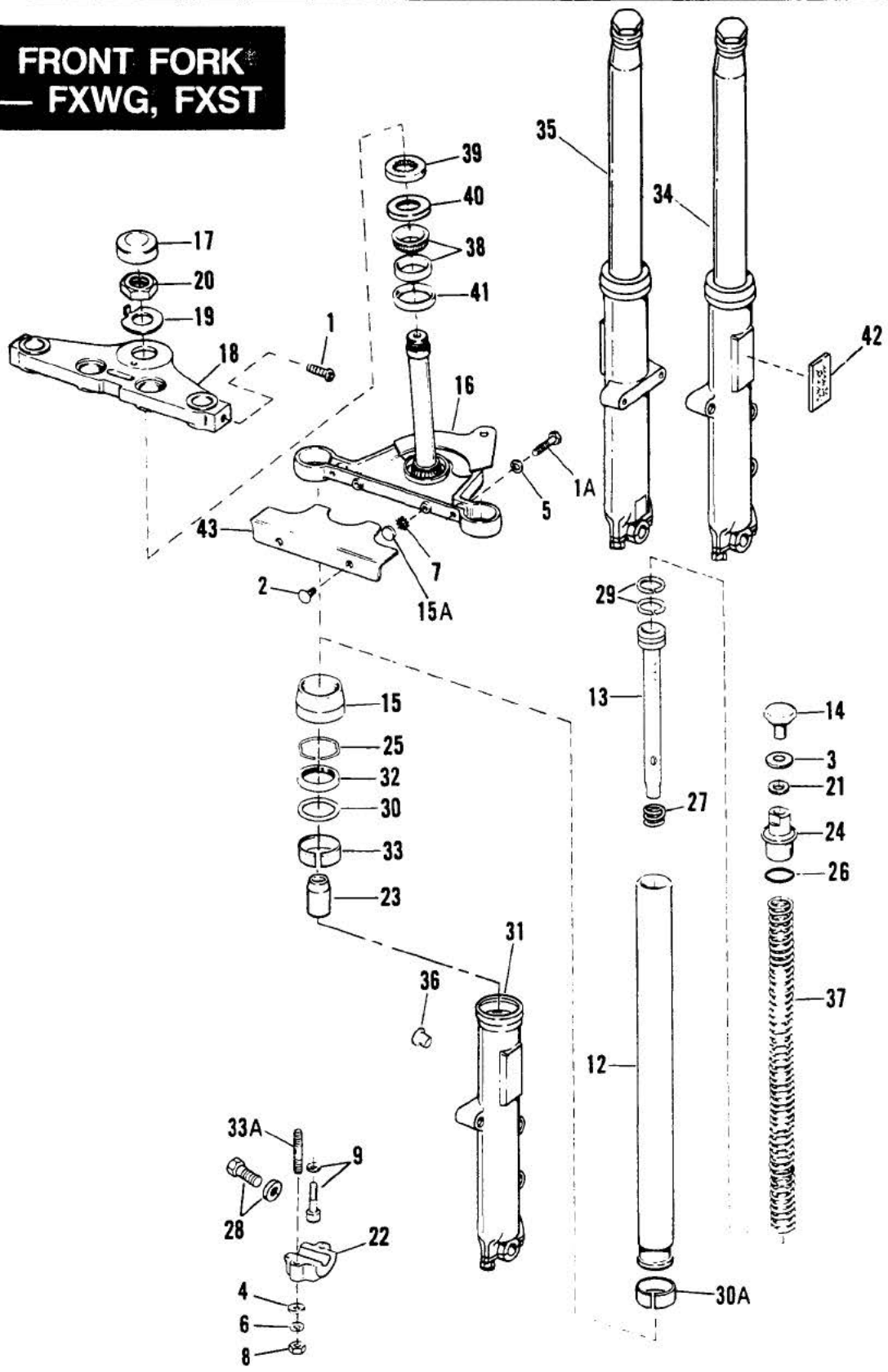

RETAIL PRICE	INDEX NO.	PART NO.	NAME	USED ON
	1	2823	SCREW (2)	86 to * — FXWG, FXST
	1A	4729	BOLT (2)	84 to * — FXST; 85 to * — FXWG
	2	5410	SCREW (chrome) (2)	84 & Early 85 — FXST; Early 85 — FXWG
	3	5710	SPACER (2)	84 to * — FXST; 85 to * — FXWG
	4	6702	WASHER, right slider (2)	84 to * — FXST; 85 to * — FXWG
	5	7039	LOCKWASHER (2)	84 to * — FXST; 85 to * — FXWG
	6	7041	LOCKWASHER, right slider (2)	84 to * — FXST; 85 to * — FXWG
	7	7232	LOCKWASHER (2)	84 & Early 85 — FXST; Early 85 — FXWG
	8	7748W	NUT, right slider (2)	84 to * — FXST; 85 to * — FXWG
	9	45405—75A	SCREW & WASHER, damper tube (2)	84 to * — FXST; 85 to * — FXWG
	12	45417—84	SLIDER TUBE (2)	84 to * — FXST; 85 to * — FXWG
	13	45418—84	DAMPER TUBE, complete (2)	84 to * — FXST; 85 to * — FXWG
	14	45419—80	CAP, slider tube (2)	84 to * — FXST; 85 to * — FXWG
	15	45420—80	DUST COVER (2)	84 to * — FXST; 85 to * — FXWG
		45640—84A	FORK STEM BRACKET (HDI part only)	N/A
	15A	45648—85	PAD (felt) (2)	Late 85 to * — FXWG, FXST
	16	45665—84A	STEM & BRACKET, with bearing & shield	84 — FXST; 85 to * — FXWG, FXST
	17	45670—80	CAP, fork stem	84 to * — FXST; 85 to * — FXWG
	18	45672—80	BRACKET, upper (chrome)	84 to * — FXST; 85 to * — FXWG
	19	45717—63	LOCKWASHER, fork stem nut	84 to * — FXST; 85 to * — FXWG
	20	45718—60	NUT, fork stem	84 to * — FXST; 85 to * — FXWG
	21	45733—48	OIL SEAL, fork tube plug (2)	84 to * — FXST; 85 to * — FXWG
	22	45832—77A	AXLE CAP, right slider	84 to * — FXST; 85 to * — FXWG
	23	45834—77	LOWER STOP (2)	84 to * — FXST; 85 to * — FXWG
	24	45838—77	PLUG, fork tube (2)	84 to * — FXST; 85 to * — FXWG
	25	45842—77	RETAINING RING, oil seal (2)	84 to * — FXST; 85 to * — FXWG
	26	45845—77	O-RING, slider tube plug (2)	84 to * — FXST; 85 to * — FXWG
	27	45855—77	SPRING, damper tube (2)	84 to * — FXST; 85 to * — FXWG
	28	45858—77	DRAIN SCREW WITH WASHER, slider (2)	84 to * — FXST; 85 to * — FXWG
	29	45859—77	RING, damper tube (4)	84 to * — FXST; 85 to * — FXWG
	30	45865—84	WASHER, slider (2)	84 to * — FXST; 85 to * — FXWG
	30A	45866—84	BUSHING, slider tube (2)	84 to * — FXST; 85 to * — FXWG
	31	45873—84	SLIDER, left	84 to * — FXST; 85 to * — FXWG
		45874—84	SLIDER, right	84 to * — FXST; 85 to * — FXWG
	32	45875—84	OIL SEAL, slider (2)	84 to * — FXST; 85 to * — FXWG
	33	45940—84	BUSHING, slider (2)	84 to * — FXST; 85 to * — FXWG
	33A	45998—73	STUD (4)	84 to * — FXST; 85 to * — FXWG
	34	46004—84	FORK SLIDER & TUBE ASSEMBLY, left	84 to * — FXST; 85 to * — FXWG
	35	46006—84	FORK SLIDER & TUBE ASSEMBLY, right	84 to * — FXST; 85 to * — FXWG
	36	46020—84	BUSHING, upper — left slider — brake caliper	84 to * — FXST; 85 to * — FXWG
	37	46048—84	SPRING (2)	84 to * — FXST; 85 to * — FXWG
		48140—84	FORK LOCK TUMBLER (HDI part only)	86 to * — FXST
	38	48300—60	ROLLER BEARING, with cup (2)	84 to * — FXST; 85 to * — FXWG
	39	48330—48A	BEARING CUP, upper — with guard	84 to * — FXST; 85 to * — FXWG
		48332—48B	BEARING CUP, upper	84 to * — FXST; 85 to * — FXWG
	40	48361—80	DUST SHIELD, bearing — upper	84 to * — FXST; 85 to * — FXWG
	41	48365—48A	DUST SHIELD, bearing — lower	84 to * — FXST; 85 to * — FXWG
	42	59254—72	REFLECTOR (amber) (2)	84 to * — FXST; 85 to * — FXWG
	43	67773—80A	MOUNTING PLATE, headlamp (chrome)	84 — FXST; 85 to * — FXWG, FXST

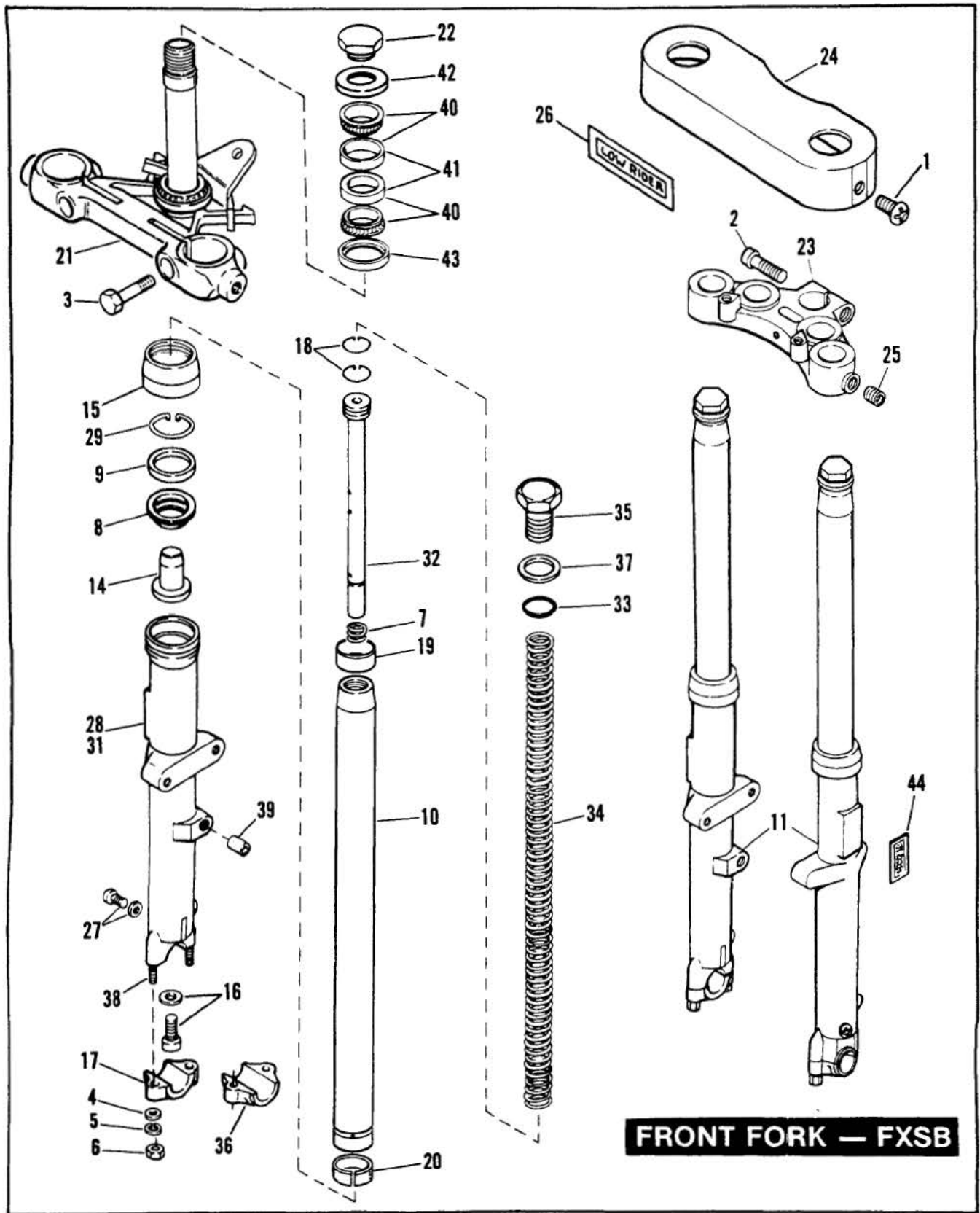

**FRONT FORK — FXSB**

RETAIL PRICE	INDEX NO.	PART NO.	NAME	USED ON
	1	2823	SCREW (4) .....	85 — FXSB
	2	4371W	SCREW .....	85 — FXSB
	3	4411	BOLT (2) .....	Early 85 — FXSB
		4724	BOLT (2) .....	Late 85 — FXSB
	4	6702	WASHER (4) .....	85 — FXSB
	5	7041	LOCKWASHER (4) .....	85 — FXSB
	6	7748W	NUT (4) .....	85 — FXSB
	7	45382—83	SPRING, damper tube (2) .....	85 — FXSB
	8	45386—83	SPACER, oil seal (2) .....	85 — FXSB
	9	45387—83	OIL SEAL (2) .....	85 — FXSB
	10	45392—83	SLIDER TUBE (2) .....	85 — FXSB
	11	45396—84	FORK SLIDER & TUBE ASSEMBLY, left .....	N/A
		45397—84	FORK SLIDER & TUBE ASSEMBLY, right .....	85 — FXSB
	14	45403—84	LOWER STOP (2) .....	85 — FXSB
	15	45404—75	DUST COVER (2) .....	85 — FXSB
	16	45405—75A	SCREW & WASHER, damper tube (2) .....	85 — FXSB
	17	45410—84	AXLE CAP, left slider .....	85 — FXSB
	18	45412—75	RING, damper tube (4) .....	85 — FXSB
	19	45413—84	BUSHING, slider tube — upper (2) .....	85 — FXSB
	20	45416—84	BUSHING, slider tube — lower (2) .....	85 — FXSB
	21	45608—84	STEM & BRACKET, with bearing & shield .....	85 — FXSB
	22	45718—71	NUT, fork stem .....	85 — FXSB
	23	45736—78B	BRACKET, upper (polished) .....	85 — FXSB
	24	45751—71A	COVER, fork lower bracket .....	85 — FXSB
	25	45782—72A	SCREW INSERT (2) .....	85 — FXSB
	26	45788—84	NAMEPLATE, front fork "LOW RIDER" .....	85 — FXSB
	27	45790—80	DRAIN SCREW, with washer (2) .....	85 — FXSB
	28	45906—84	SLIDER, right — complete .....	85 — FXSB
	29	45908—80	RETAINING RING, oil seal (2) .....	85 — FXSB
	31	45912—84	SLIDER, left — complete .....	85 — FXSB
	32	45914—84	DAMPER TUBE — complete (2) .....	85 — FXSB
	33	45982—73	O-RING, slider tube cap (2) .....	85 — FXSB
	34	45987—84	SPRING (2) .....	85 — FXSB
	35	45993—73	CAP, slider tube (2) .....	85 — FXSB
	36	45994—84	AXLE CAP, right slider .....	85 — FXSB
	37	45997—73	WASHER, slider tube cap (2) .....	85 — FXSB
	38	45998—73	STUD, 5/16-18, both ends (4) .....	85 — FXSB
	39	46020—84	BUSHING, brake caliper — left slider .....	85 — FXSB
	40	48300—60	ROLLER BEARING, with cup (2) .....	85 — FXSB
	41	48315—60	BEARING CUP (2) .....	85 — FXSB
	42	48361—80	DUST SHIELD, bearing — upper .....	85 — FXSB
	43	48365—48A	DUST SHIELD, bearing — lower .....	85 — FXSB
	44	59254—72	REFLECTOR (amber) (2) .....	85 — FXSB

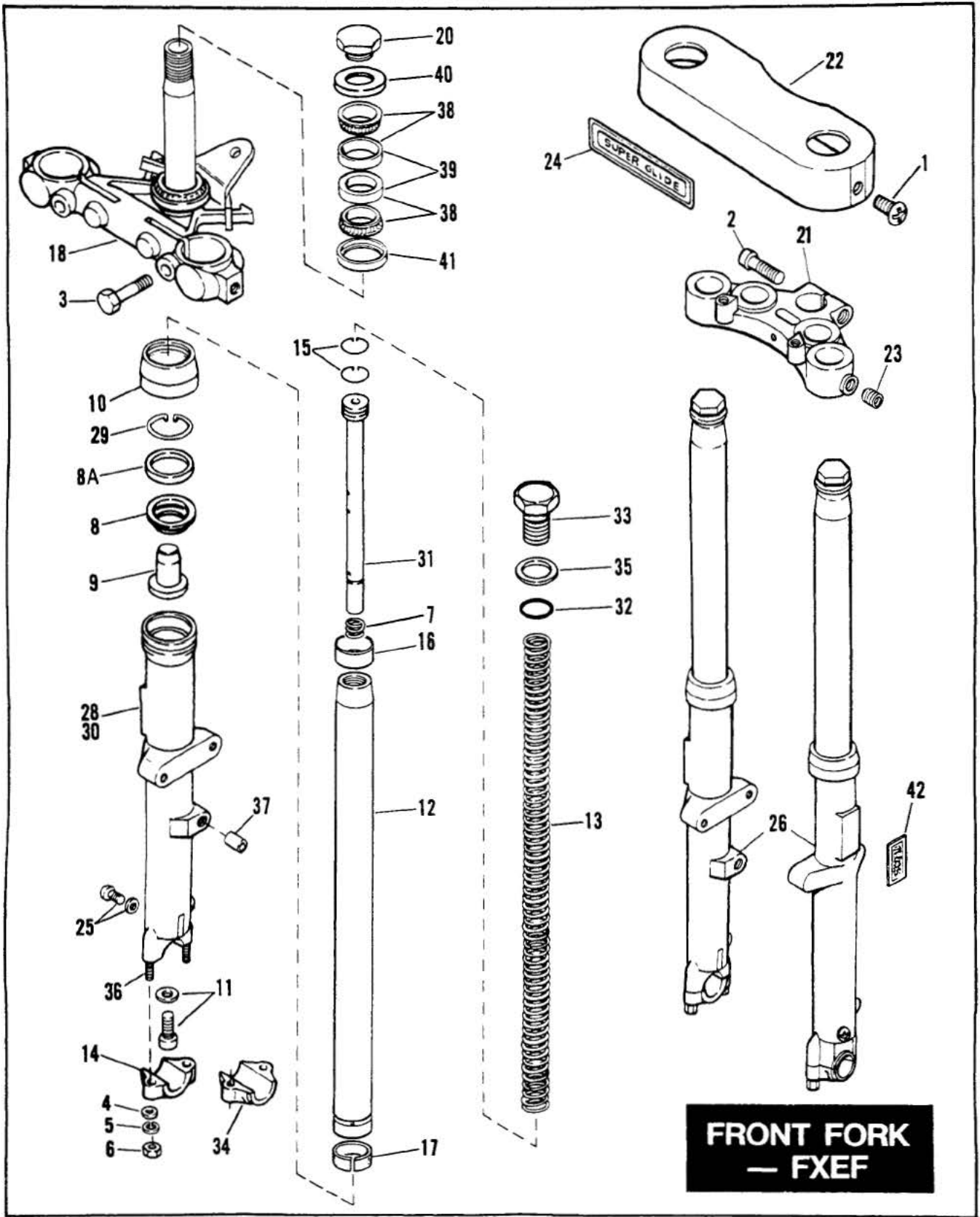

RETAIL PRICE	INDEX NO.	PART NO.	NAME	USED ON
	1	2823	SCREW (4) .....	85 — FXEF
	2	4371W	SCREW .....	85 — FXEF
	3	4411	BOLT (2) .....	Early 85 — FXEF
		4724	BOLT (2) .....	Late 85 — FXEF
	4	6702	WASHER (4) .....	85 — FXEF
	5	7041	LOCKWASHER (4) .....	85 — FXEF
	6	7748W	NUT (4) .....	85 — FXEF
	7	45382—83	SPRING, damper tube (2) .....	85 — FXEF
	8	45386—83	SPACER, oil seal (2) .....	85 — FXEF
	8A	45387—83	OIL SEAL (2) .....	85 — FXEF
	9	45403—84	LOWER STOP (2) .....	85 — FXEF
	10	45404—75	DUST COVER (2) .....	85 — FXEF
	11	45405—75A	SCREW & WASHER, damper tube (2) .....	85 — FXEF
	12	45407—83	SLIDER TUBE (2) .....	85 — FXEF
	13	45408—84	SPRING (2) .....	85 — FXEF
	14	45410—84	AXLE CAP, left slider .....	85 — FXEF
	15	45412—75	RING, damper tube (4) .....	85 — FXEF
	16	45413—84	BUSHING, slider tube — upper (2) .....	85 — FXEF
	17	45416—84	BUSHING, slider tube — lower (2) .....	85 — FXEF
	18	45608—84	STEM & BRACKET, with bearing & shield .....	85 — FXEF
	20	45718—60	NUT, fork stem .....	85 — FXEF
	21	45736—78B	BRACKET, upper (polished) .....	85 — FXEF
	22	45751—71A	COVER, fork lower bracket .....	85 — FXEF
	23	45782—72A	SCREW INSERT (2) .....	85 — FXEF
	24	45785—82	NAMEPLATE, front fork "SUPER GLIDE" .....	N/A
	25	45790—80	DRAIN SCREW, with washer (2) .....	85 — FXEF
	26	45903—84A	FORK SLIDER & TUBE ASSEMBLY, right .....	85 — FXEF
	27	45904—84A	FORK SLIDER & TUBE ASSEMBLY, left .....	85 — FXEF
	28	45906—84	SLIDER, right — complete .....	85 — FXEF
	29	45908—80	RETAINING RING, oil seal (2) .....	85 — FXEF
	30	45912—84	SLIDER, left — complete .....	85 — FXEF
	31	45914—84	DAMPER TUBE — complete (2) .....	85 — FXEF
	32	45982—73	O-RING, slider tube cap (2) .....	85 — FXEF
	33	45993—73	CAP, slider tube (2) .....	85 — FXEF
	34	45994—84	AXLE CAP, right slider .....	85 — FXEF
	35	45997—73	WASHER, slider tube cap (2) .....	85 — FXEF
	36	45998—73	STUD, 5/16-18, both ends (4) .....	85 — FXEF
	37	46020—84	BUSHING, brake caliper — left slider .....	85 — FXEF
	38	48300—60	ROLLER BEARING, with cup (2) .....	85 — FXEF
	39	48315—60	BEARING CUP (2) .....	85 — FXEF
	40	48361—80	DUST SHIELD, bearing — upper .....	85 — FXEF
	41	48365—48A	DUST SHIELD, bearing — lower .....	85 — FXEF
	42	59254—72	REFLECTOR (amber) (2) .....	85 — FXEF

**FRAME AND REAR FORK  
— FXWG, FXSB, FXEF**

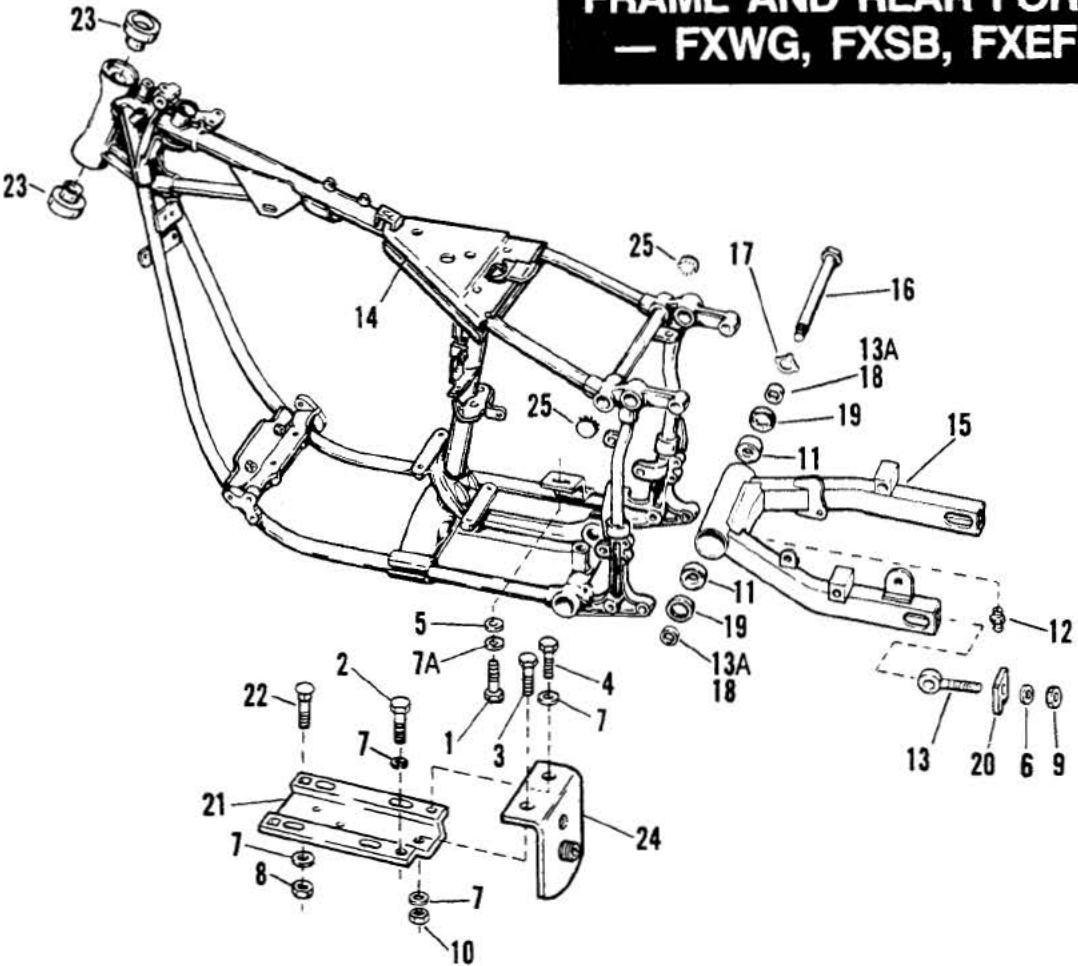

RETAIL PRICE	INDEX NO.	PART NO.	NAME	USED ON
	1	2851	BOLT .....	85 to * — FXWG, FXSB, FXEF
	2	4319	BOLT .....	85 to * — FXWG, FXSB, FXEF
	3	4337W	BOLT .....	85 to * — FXWG, FXSB, FXEF
	4	4724	BOLT .....	85 to * — FXWG, FXSB, FXEF
	5	6026	WASHER .....	85 to * — FXWG, FXSB, FXEF
	6	6702	WASHER (2) .....	85 to * — FXWG, FXSB, FXEF
	7	7038	LOCKWASHER (5) .....	85 to * — FXWG, FXSB, FXEF
	7A	7130W	LOCKWASHER .....	85 to * — FXWG, FXSB, FXEF
	8	7643W	JAMNUT (2) .....	85 to * — FXWG, FXSB, FXEF
	9	7725	LOCKNUT (2) .....	85 to * — FXWG, FXSB, FXEF
	10	7800W	NUT .....	85 to * — FXWG, FXSB, FXEF
	11	9052	ROLLER BEARING (2) .....	85 to * — FXWG, FXSB, FXEF
	12	9851	GREASE FITTING, rear fork .....	85 to * — FXWG, FXSB, FXEF
	13	41570—77	ADJUSTER, rear axle (2) .....	85 to * — FXWG, FXSB, FXEF
	13A	43358—83A	SPACER, pivot bearing (2) .....	Late 85 to * — FXWG, FXSB, FXEF
	14	47013—85	FRAME .....	85 to * — FXWG, FXSB, FXEF
	15	47446—82	REAR FORK .....	85 to * — FXWG, FXSB
		47498—62A	REAR FORK .....	85 — FXEF
	16	47510—58	PIVOT BOLT, rear fork .....	85 to * — FXWG, FXSB, FXEF
	17	47513—58	LOCKWASHER, pivot bolt .....	85 to * — FXWG, FXSB, FXEF
	18	47517—58	SPACER, pivot bearing (2) .....	Early 85 — FXWG, FXSB, FXEF
	19	47519—72	SEAL, pivot bearing (2) .....	85 to * — FXWG, FXSB, FXEF
	20	47554—73	END COVER, rear fork .....	85 to * — FXWG, FXSB, FXEF
	21	47698—65C	TRANSMISSION MOUNTING PLATE .....	85 to * — FXWG, FXSB, FXEF
	22	47730—77	CARRIAGE BOLT, transmission mounting plate (2) .....	85 to * — FXWG, FXSB, FXEF
	23	48311—60	BEARING CUP, frame (2) .....	85 to * — FXWG, FXSB, FXEF
	24	62538—82	MOUNTING BRACKET, spin-on oil filter .....	85 to * — FXWG, FXSB, FXEF
	25	68797—68A	END PLUG, frame (2) .....	85 to * — FXWG



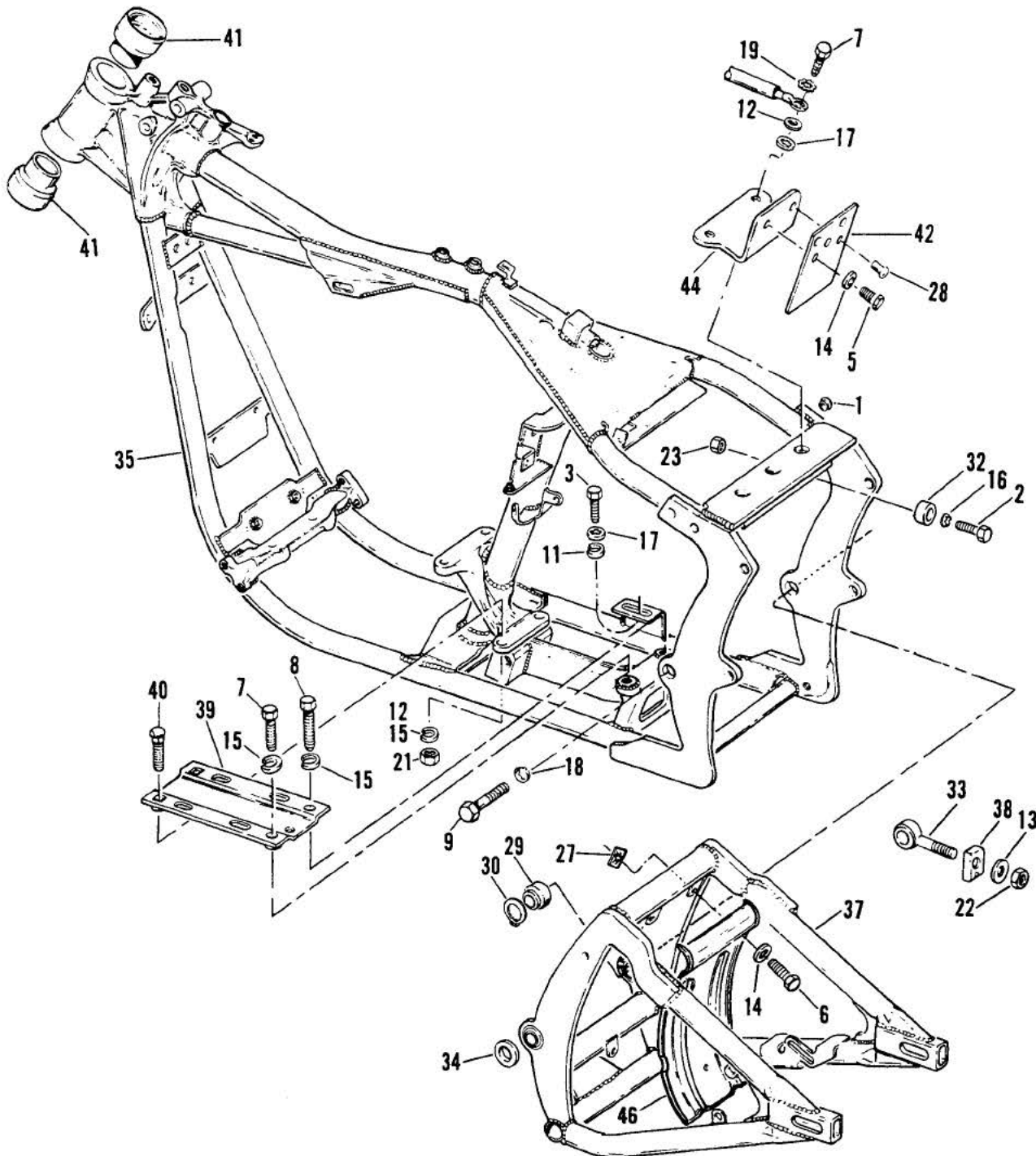

**FRAME AND REAR FORK  
FXST — 1984 AND 1985**

RETAIL PRICE	INDEX NO.	PART NO.	NAME	USED ON
	1	728	PLUG, frame side (2)	84 & 85 — FXST
	2	2722	SCREW (2)	84 & 85 — FXST
	3	2851	BOLT	84 & 85 — FXST
	5	3728	BOLT (2)	84 & Early 85 — FXST
	6	3767B	BOLT (3)	84 & 85 — FXST
	7	4319	BOLT (2)	84 & 85 — FXST
	8	4337W	BOLT	84 & 85 — FXST
	9	4969	BOLT (2)	84 & 85 — FXST
	11	6026	WASHER	84 & 85 — FXST
	12	6701	WASHER (3)	84 & 85 — FXST
	13	6702	WASHER (2)	84 & 85 — FXST
	14	6703	WASHER (5; 3 — Late 85)	84 & 85 — FXST
	15	7038	LOCKWASHER (4)	84 & 85 — FXST
	16	7124	LOCKWASHER (2)	84 & 85 — FXST
	17	7130W	LOCKWASHER (2)	84 & 85 — FXST
	18	7142	LOCKWASHER (2)	84 & 85 — FXST
	19	7145W	LOCKWASHER	84 & 85 — FXST
	21	7643W	JAM NUT (2)	84 & 85 — FXST
	22	7725	NUT (2)	84 & 85 — FXST
	23	7742	JAM NUT (2)	84 & 85 — FXST
	27	8108	SPEED NUT (3)	Late 85 — FXST
		8123	SPEED NUT (3)	Early 84 — FXST
	28	8483	RIVET (2)	Late 85 — FXST
	29	9076	BEARING, rear fork pivot (2)	84 & 85 — FXST
	30	11158	RETAINING RING, fork bearing (2)	84 & 85 — FXST
	32	11469	CUSHION, frame (2)	84 & 85 — FXST
	33	41570—77	ADJUSTER, rear axle (2)	84 & 85 — FXST
	34	43283—84	WASHER, rear fork pivot (2)	84 & 85 — FXST
	35	47008—84	FRAME	84 & 85 — FXST
	37	47537—84	REAR FORK	84 & 85 — FXST
	38	47554—73	END COVER, rear fork (chrome) (2)	84 & 85 — FXST
	39	47698—65C	TRANSMISSION MOUNTING PLATE	84 & 85 — FXST
	40	47730—77	BOLT, transmission mounting plate (2)	84 & 85 — FXST
	41	48311—60	BEARING CUP, frame (2)	84 & 85 — FXST
	42	59648—84	DEBRIS DEFLECTOR, upper	84 & 85 — FXST
	44	59692—84	BRACKET, debris deflector	84 & Early 85 — FXST
	46	60363—84	DEBRIS DEFLECTOR, lower	84 & 85 — FXST

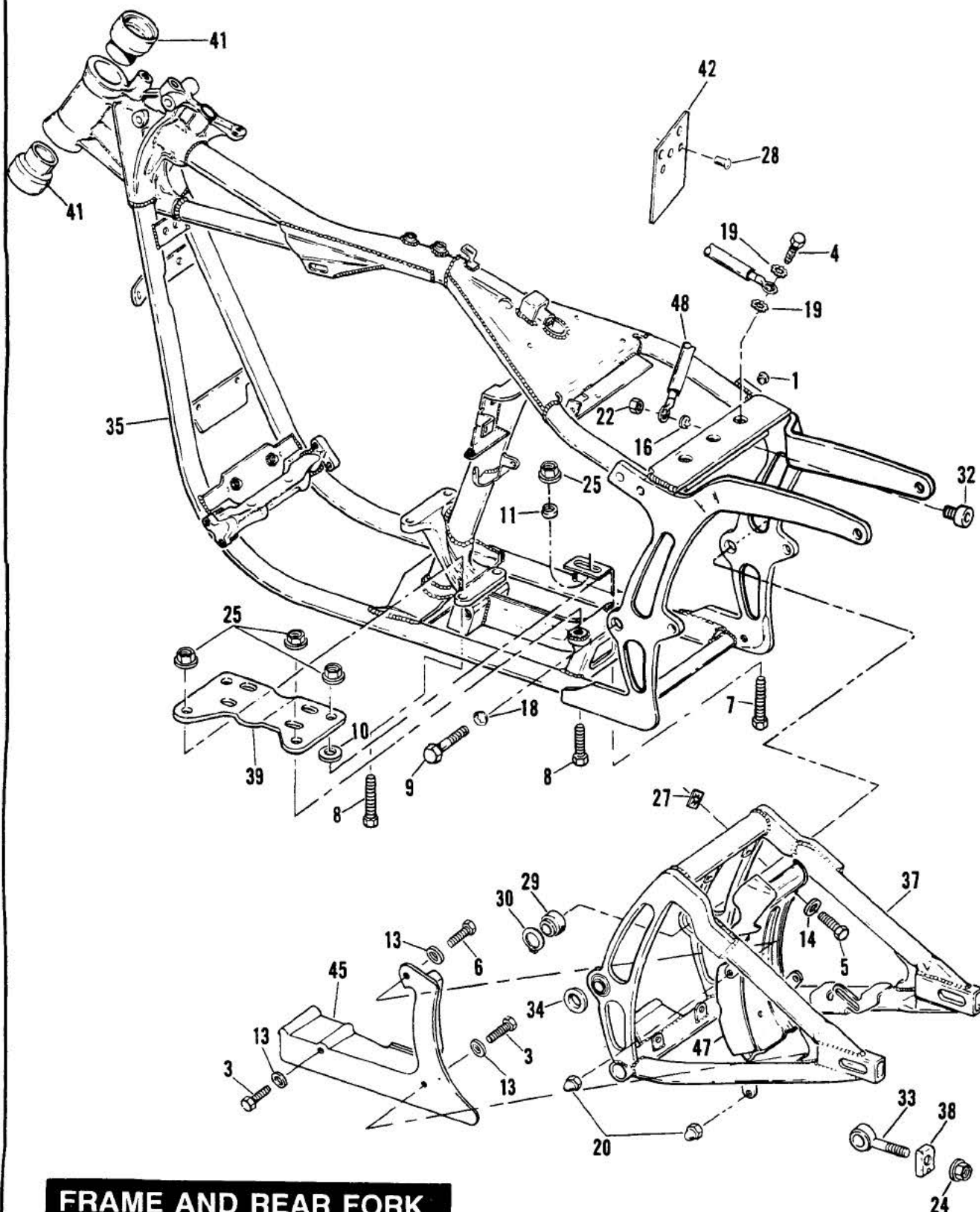

**FRAME AND REAR FORK  
FXST — 1986 AND LATER**

RETAIL PRICE	INDEX NO.	PART NO.	NAME	USED ON
	1	728	PLUG, frame side (2)	86 to * — FXST
	3	2882W	BOLT (2)	86 to * — FXST
	4	3440	BOLT	86 to * — FXST
	5	3728B	BOLT (4)	86 to * — FXST
	6	3987	BOLT	86 to * — FXST
	7	4319	BOLT, under frame & bracket	86 to * — FXST
	8	4724	BOLT, under frame & bracket (3)	86 to * — FXST
	9	4961	BOLT (2)	86 to * — FXST
	10	6019	WASHER (2)	86 to * — FXST
	11	6474	WASHER	86 to * — FXST
	13	6702	WASHER (3)	86 to * — FXST
	14	6703	WASHER (4)	86 to * — FXST
	16	7124	LOCKWASHER	86 to * — FXST
	18	7142	LOCKWASHER (2)	86 to * — FXST
	19	7145W	LOCKWASHER (2)	86 to * — FXST
	20	7507	ACORN NUT (2)	86 to * — FXST
	22	7689W	JAM NUT (2)	86 to * — FXST
	24	7767	FLANGE NUT (2)	86 to * — FXST
	25	7782	FLANGE NUT (4)	86 to * — FXST
	27	8108	SPEED NUT (4)	86 to * — FXST
	28	8692	RIVET (3)	86 to * — FXST
	29	9076	BEARING, rear fork pivot (2)	86 to * — FXST
	30	11158	RETAINING RING, fork bearing (2)	86 to * — FXST
	32	11451	CUSHION, (2)	86 to * — FXST
	33	41583—84	ADJUSTER, rear axle (2)	86 to * — FXST
	34	43283—86	SPACER, rear fork pivot (2)	86 to * — FXST
	35	47008—86	FRAME	86 to * — FXST
		48130—86	FRAME ASSEMBLY (HDI part only)	86 to * — FXST
	37	47537—86	REAR FORK	86 to * — FXST
	38	47548—84	END COVER, rear fork (2)	86 to * — FXST
	39	47698—86A	TRANSMISSION MOUNTING PLATE	86 to * — FXST
	41	48311—60	BEARING CUP, frame (2)	86 to * — FXST
	42	59648—84A	DEBRIS DEFLECTOR, upper (see SECTION FX34)	86 to * — FXST
	45	60362—86	DEBRIS DEFLECTOR, belt	86 to * — FXST
	47	60363—86A	DEBRIS DEFLECTOR, lower	86 to * — FXST
	48	70008—86	GROUND WIRE, starter relay	86 to * — FXST

# JIFFY STAND

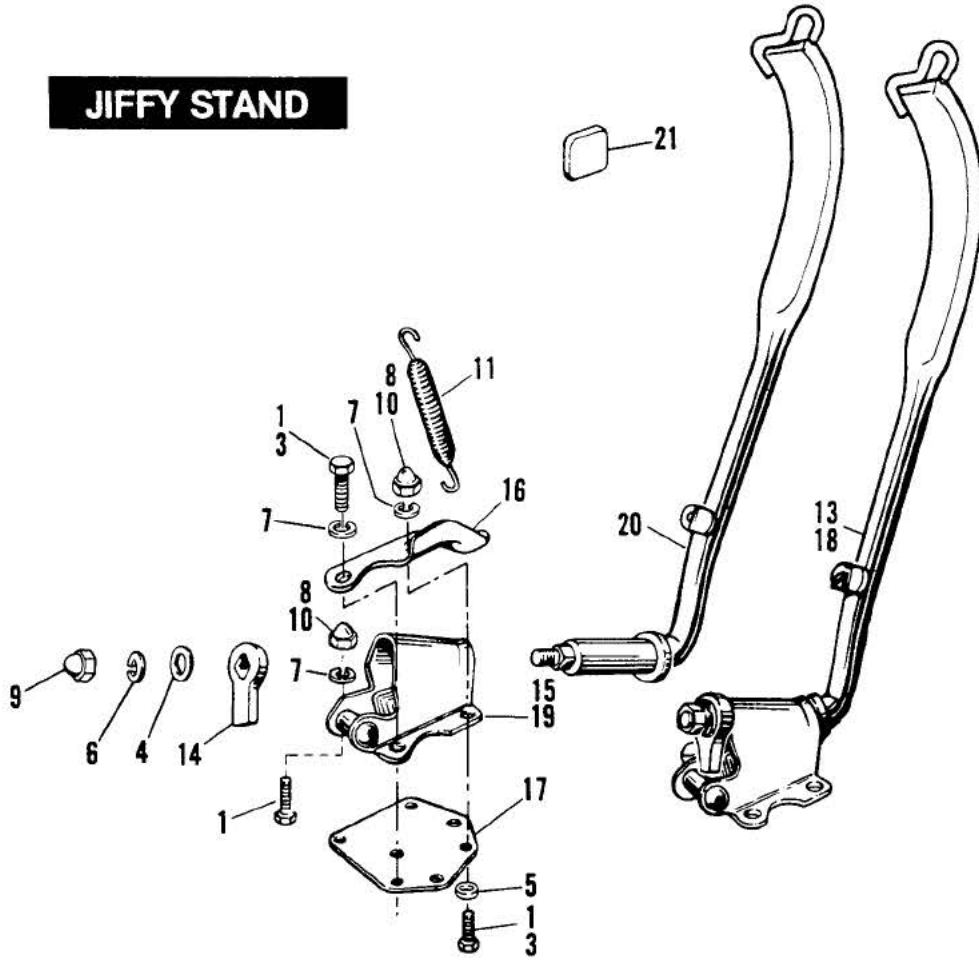

RETAIL PRICE	INDEX NO.	PART NO.	NAME	USED ON
	1	3960W	BOLT (4 — 1984; 3 — FXSB-1985 & Later)	84 — FXST; 85 to * — All Models
		3996	BOLT (3)	85 to * — FXWG, FXEF
	3	4014W	BOLT (2 — FXST)	85 to * — FXSB, FXST
	4	6334	WASHER	84 — FXST; 85 to * — All Models
	5	6702	WASHER	85 — FXSB
	6	7039	LOCKWASHER	84 — FXST; 85 to * — All Models
	7	7041	LOCKWASHER (4)	84 — FXST; 85 to * — All Models
	8	7508	ACORN NUT (3)	85 to * — FXWG, FXEF
	9	7513	ACORN NUT	84 — FXST; 85 to * — All Models
	10	7736	ACORN NUT (chrome) (4: 3 — 1985 & Later)	84 — FXST; 85 to * — All Models
	11	50005—85	SPRING, jiffy stand leg	85 to * — All Models
		50011—30A	SPRING, jiffy stand leg	84 — FXST
	13	50013—85	JIFFY STAND ASSEMBLY (chrome) N/A	85 — FXEF
	14	50015—74	LEG STOP	84 — FXST; 85 to * — All Models
	15	50018—85	LEG BRACKET (chrome)	85 — FXEF
	16	50028—74A	BRACKET, spring (chrome)	85 to * — All Models
	17	50036—74	REINFORCEMENT PLATE, jiffy stand	85 — FXEF
	18	50040—80	JIFFY STAND ASSEMBLY (chrome) N/A	84 — FXST
		50040—85	JIFFY STAND ASSEMBLY (chrome) N/A	85 to * — FXWG, FXSB, FXST
	19	50041—80A	LEG BRACKET (chrome)	84 — FXST
		50041—85	LEG BRACKET (chrome)	85 to * — FXWG, FXSB, FXST
	20	50061—36E	LEG, jiffy stand (chrome)	84 — FXST
		50061—85	LEG, jiffy stand (chrome)	85 to * — All Models
	21	50100—70	BUMPER, jiffy stand	84 — FXST; 85 to * — All Models

# SEATS AND SISSYBAR

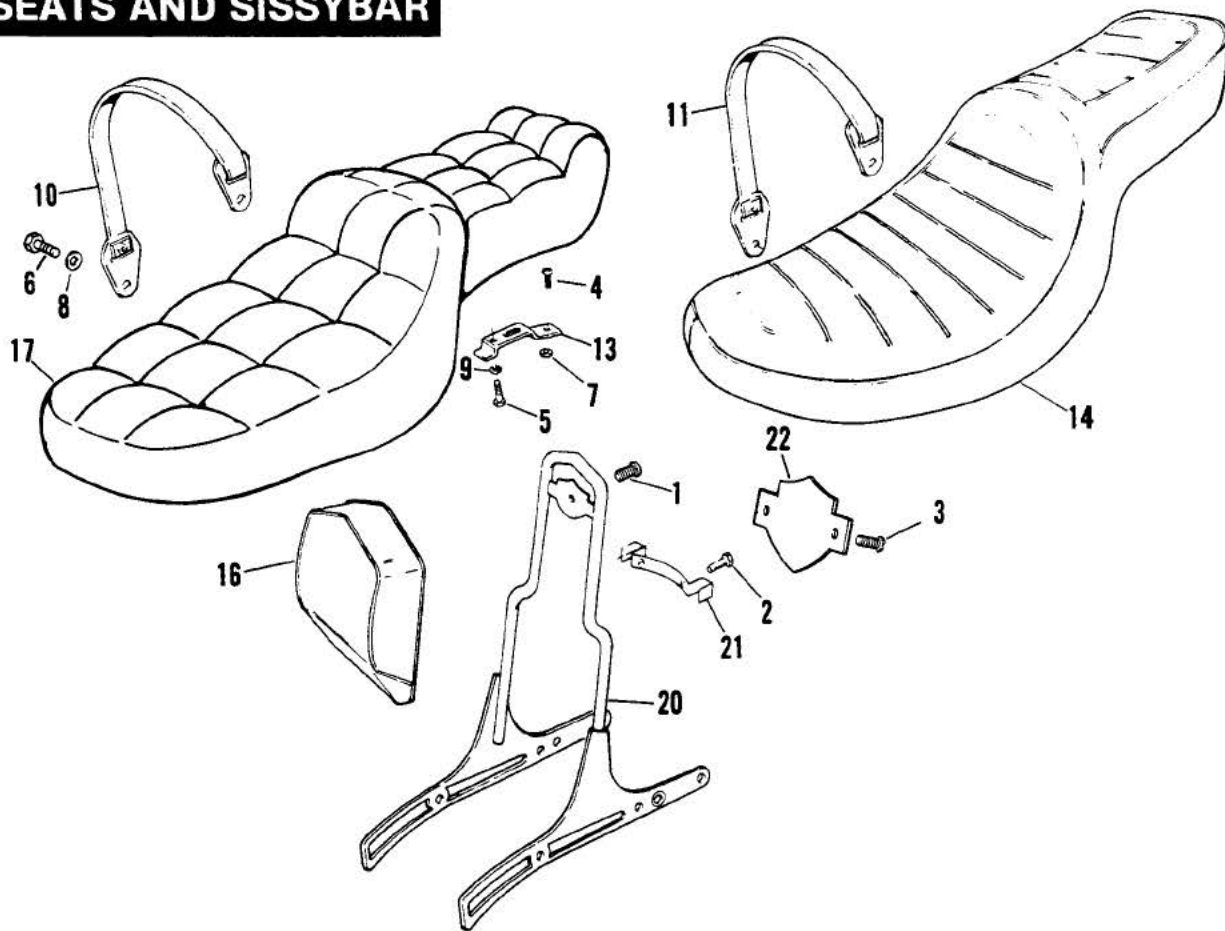

## SEAT

FX29

RETAIL PRICE	INDEX NO.	PART NO.	NAME	USED ON
	1	1602	SCREW	85 to * — FXWG, FXSB
	2	2607	SCREW (2)	85 to * — FXWG, FXSB
	3	2711	SCREW (2)	85 to * — FXWG, FXSB
	4	2757W	SCREW	84 — FXST; 85 to * — All Models
	5	3767B	BOLT (2)	84 — FXST; 85 to * — All Models
	6	4319	BOLT (2)	84 to * — FXST
	7	6410	WASHER (nylon)	84 — FXST; 85 to * — All Models
	8	6701	WASHER (2)	84 to * — FXST
	9	7036	LOCKWASHER (2)	84 — FXST; 85 to * — All Models
	10	51188—84	PASSENGER STRAP (black)	84 & 85 — FXST
		51188—86	PASSENGER STRAP (black)	86 to * — FXST
	11	51192—83	PASSENGER STRAP (black)	85 to * — FXWG
		51195—80	PASSENGER STRAP (black)	85 — FXSB, FXEF
	13	51652—83	BRACKET, seat	84 — FXST; 85 to * — All Models
	14	52179—85	SEAT, 1-piece (black)	N/A 85 — FXEF
	16	52495—88	BACKREST, sissy bar	85 to * — FXWG, FXSB
	17	52498—85	SEAT, 2-piece (black)	85 to * — FXWG
		52499—85	SEAT, 2-piece (black)	85 — FXSB
		52501—84	SEAT, 2-piece — accordion pleats (black)	84 to * — FXST
	20	52743—82A	SISSY BAR	N/A 85 — FXSB
		52744—82A	SISSY BAR	N/A 85 to * — FXWG
	21	52771—82	BRACKET, backrest	85 to * — FXWG, FXSB
	22	99013—82	NAMEPLATE, sissy bar	85 to * — FXWG, FXSB

# FOOTRESTS — FXWG, FXST

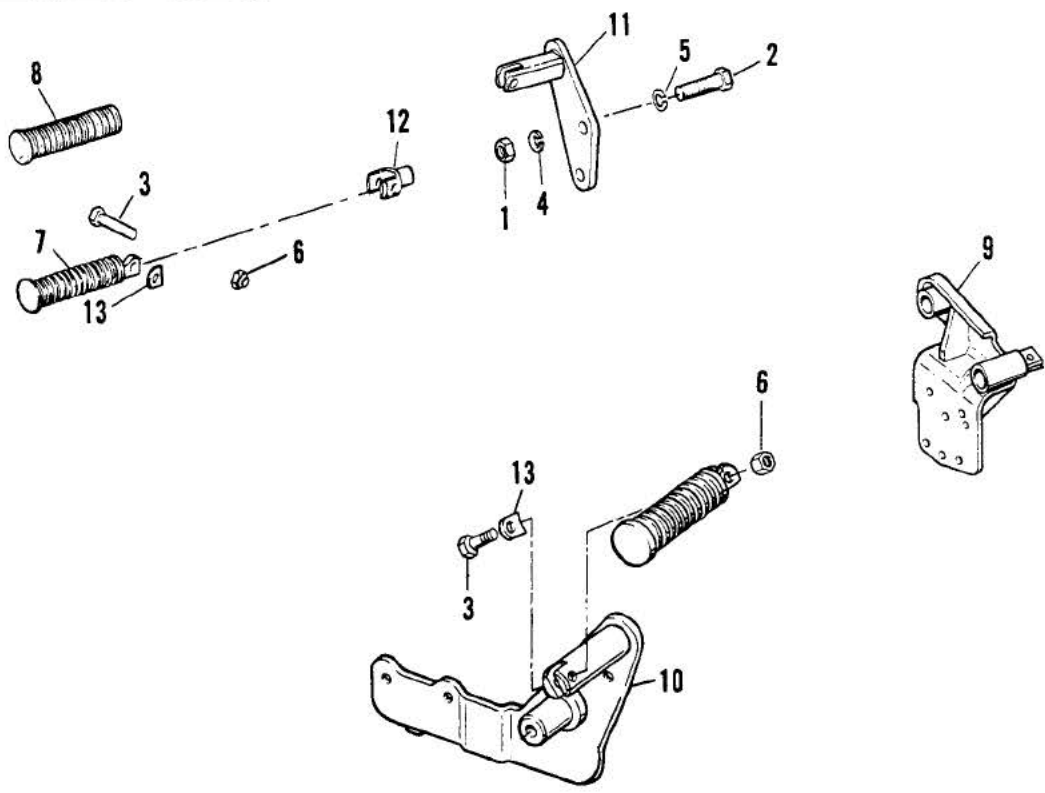

## FOOTRESTS — FXWG, FXST

FX30

RETAIL PRICE	INDEX NO.	PART NO.	NAME	USED ON
	1	2879W	BOLT (4)	85 to * — FXWG
	2	3486	BOLT (2)	84 & 85 — FXST
		3516	BOLT (2)	86 to * — FXST
	3	4337W	BOLT	86 to * — FXST
		4721	BOLT (4; 3 — 86 & Later)	84 & 85 — FXST; 85 to * — FXWG
	4	7038	LOCKWASHER (4)	85 to * — FXWG
	5	7068	LOCKWASHER (2)	84 to * — FXST
	6	7776W	LOCKNUT	86 to * — FXST
		7778	LOCKNUT (4; 3 — 86 & Later)	84 & 85 — FXST; 85 to * — FXWG
	7	33048—72	FOOTRESTS (4)	84 to * — FXST; 85 to * — FXWG
	8	33189—63	RUBBER COVER, footrests (4)	84 to * — FXST; 85 to * — FXWG
	9	33683—80	MOUNTING BRACKET, shift lever & left footrest	84 & 85 — FXST; 85 to * — FXWG
		33683—87A	MOUNTING BRACKET, shift lever & left footrest	86 to * — FXST
	10	42507—82	MOUNTING BRACKET, brake lever & right footrest	84 & 85 — FXST; 85 to * — FXWG
		42507—86	MOUNTING BRACKET, brake lever & right footrest	86 to * — FXST
	11	47107—84	BRACKET, footrest — left	85 to * — FXWG
		47108—84	BRACKET, footrest — right	85 to * — FXWG
	12	50900—72	SUPPORT, passenger footrest (2)	84 to * — FXST
	13	50912—72	SPRING WASHER, footrest mounting (4)	84 to * — FXST; 85 to * — FXWG



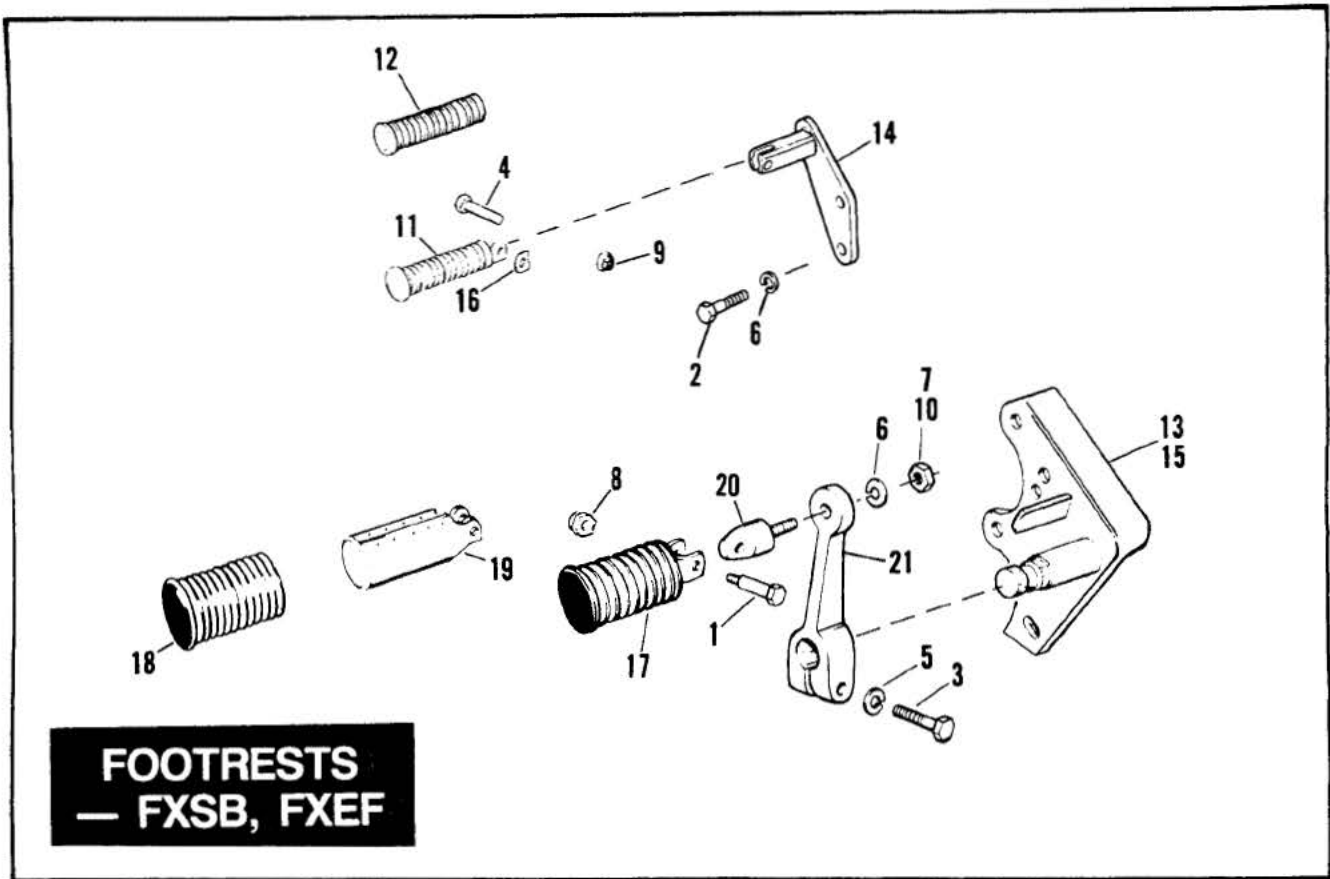

**FOOTRESTS — FXSB, FXEF**

**FX30A**

RETAIL PRICE	INDEX NO.	PART NO.	NAME	USED ON
	1	2608	SCREW, shouldered (2)	85 — FXSB, FXEF
	2	2879W	BOLT (4)	85 — FXSB, FXEF
	3	3839W	BOLT	85 — FXSB, FXEF
	4	4721	BOLT (2)	85 — FXSB, FXEF
	5	7036	LOCKWASHER	85 — FXSB, FXEF
	6	7038	LOCKWASHER (5)	85 — FXSB, FXEF
	7	7572W	LOCKNUT (2)	85 — FXSB, FXEF
	8	7739	LOCKNUT (2)	85 — FXSB, FXEF
	9	7778	LOCKNUT (2)	85 — FXSB, FXEF
	10	7800W	NUT	85 — FXSB, FXEF
	11	33048-72	FOOTREST, passenger (2)	85 — FXSB, FXEF
	12	33189-63	RUBBER PAD, passenger footrest (2)	85 — FXSB, FXEF
	13	42389-79	BRACKET, footrest — right	85 — FXSB
	14	47107-84	BRACKET, footrest — left	85 — FXSB, FXEF
		47108-84	BRACKET, footrest — right	85 — FXSB, FXEF
	15	50800-71B	BRACKET, footrest — right	85 — FXEF
	16	50912-72	SPRING WASHER (2)	85 — FXSB, FXEF
	17	50939-52	FOOTREST (2)	85 — FXSB, FXEF
	18	50940-52	RUBBER PAD, footrest (2)	85 — FXSB, FXEF
	19	50946-52	FOOTREST, only (2)	N/A 85 — FXSB, FXEF
	20	50973-65	STUD, footrest — right	85 — FXSB, FXEF
		52683-74	STUD, footrest — left	85 — FXSB, FXEF
	21	52695-77	FOOTREST SUPPORT, right — chrome	85 — FXSB, FXEF

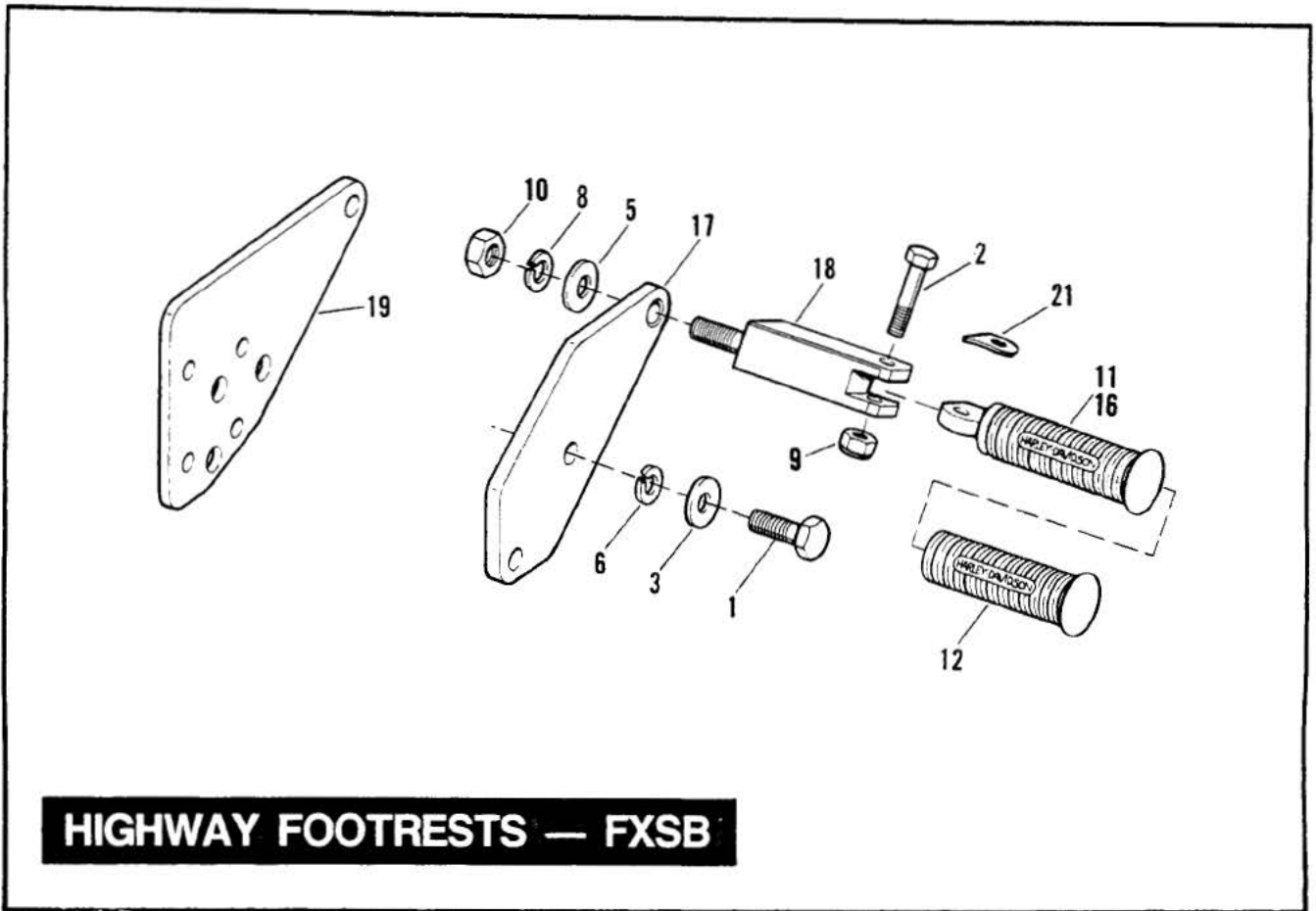

**HIGHWAY FOOTRESTS — FXSB**

**HIGHWAY FOOTRESTS — FXSB**

**FX30B**

RETAIL PRICE	INDEX NO.	PART NO.	NAME	USED ON
	1	2851	BOLT (2)	Late 85 — FXSB
		2879W	BOLT (2)	Early 85 — FXSB
	2	4721	BOLT (2)	85 — FXSB
	3	6701	WASHER (2)	85 — FXSB
	5	6718	WASHER (2)	85 — FXSB
	6	7038	LOCKWASHER (2)	85 — FXSB
	8	7068	LOCKWASHER (2)	85 — FXSB
	9	7778	LOCKNUT (2)	85 — FXSB
	10	7880	NUT (2)	85 — FXSB
	11	33048—72	FOOTREST (2)	85 — FXSB
	12	33189—63	COVER, footrest (rubber) (2)	85 — FXSB
	16	49117—77	FOOTREST (2)	85 — FXSB
	17	49126—77B	FOOTREST BRACKET, right	85 — FXSB
	18	49127—77A	FOOTREST SUPPORT, (2)	85 — FXSB
	19	49129—77	FOOTREST BRACKET, left	85 — FXSB
	21	50912—72	SPRING WASHER, footrest (2)	85 — FXSB

# SHOCK ABSORBERS — FXST

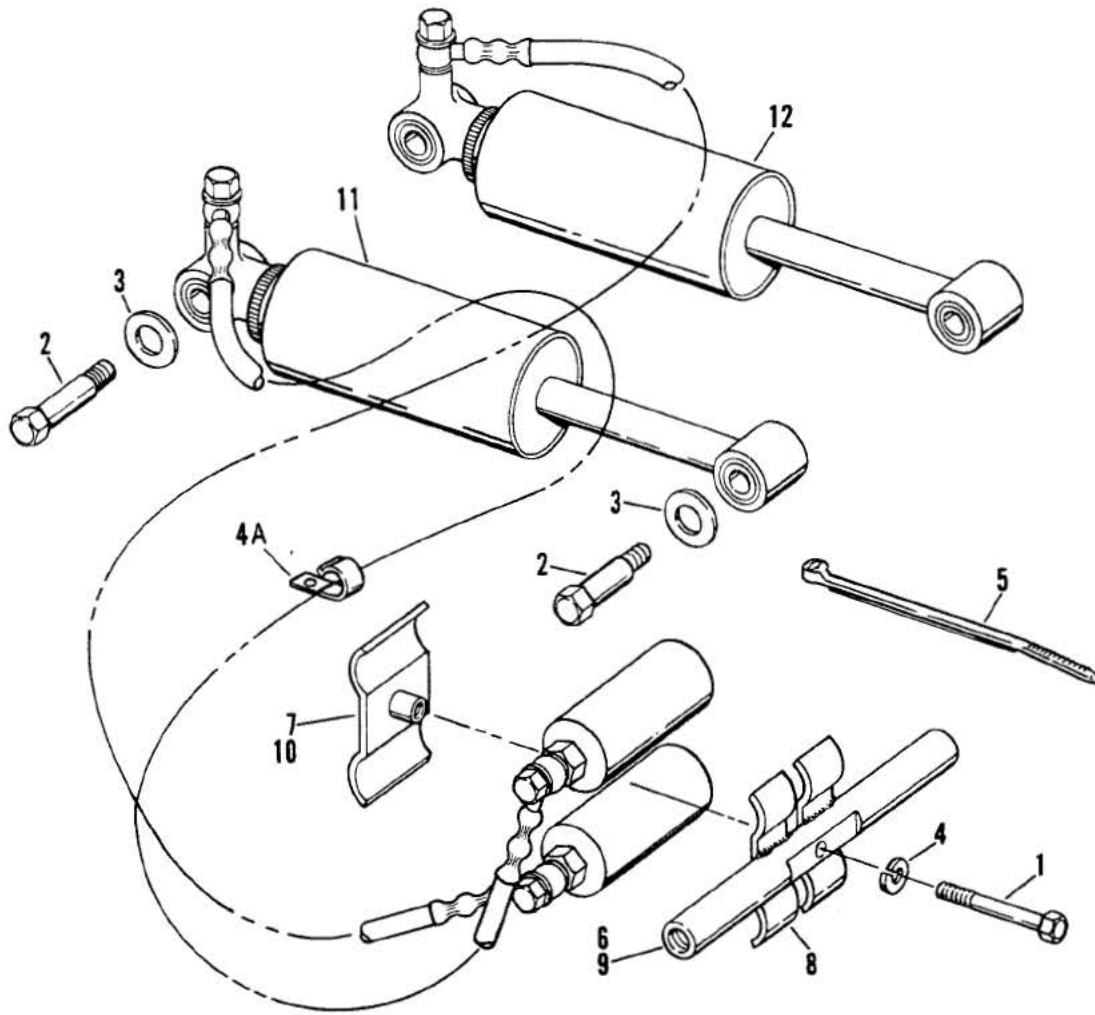

## SHOCK ABSORBERS — FXST

FX31

RETAIL PRICE	INDEX NO.	PART NO.	NAME	USED ON
	1	2667	BOLT (2 — Early 84)	84 — FXST
		2887W	BOLT	85 to * — FXST
	2	4079	BOLT (4)	84 to * — FXST
	3	6724	WASHER (4)	84 to * — FXST
	4	7041	LOCKWASHER (2 — Early 84)	84 — FXST
	4A	10003	CLAMP, left shock hose	85 to * — FXST
	5	10006	STRAP, hose — left shock absorber	84 to * — FXST
	5A	10072	CLAMP, left shock hose	86 to * — FXST
	6	47724—84	TUBE, cannister mounting	Early 84 — FXST
	7	47726—84	BRACKET, cannister mounting	Early 84 — FXST
	8	47728—84	CLAMP, cannister mounting (2)	Early 84 — FXST
	9	48030—84	BRACKET, cannister mounting — rear	Late 84 & 85 — FXST
		48030—86	BRACKET, cannister mounting — rear	86 to * — FXST
	10	48033—84	BRACKET, cannister mounting — front	Late 84 to * — FXST
	11	54508—84	SHOCK ABSORBER, complete — left	84 & 85 — FXST
		54508—86	SHOCK ABSORBER, complete — left	86 to * — FXST
	12	54520—84	SHOCK ABSORBER, complete — right	84 & 85 — FXST
		54520—86	SHOCK ABSORBER, complete — right	86 to * — FXST

# SHOCK ABSORBERS — FXWG, FXSB, FXEF

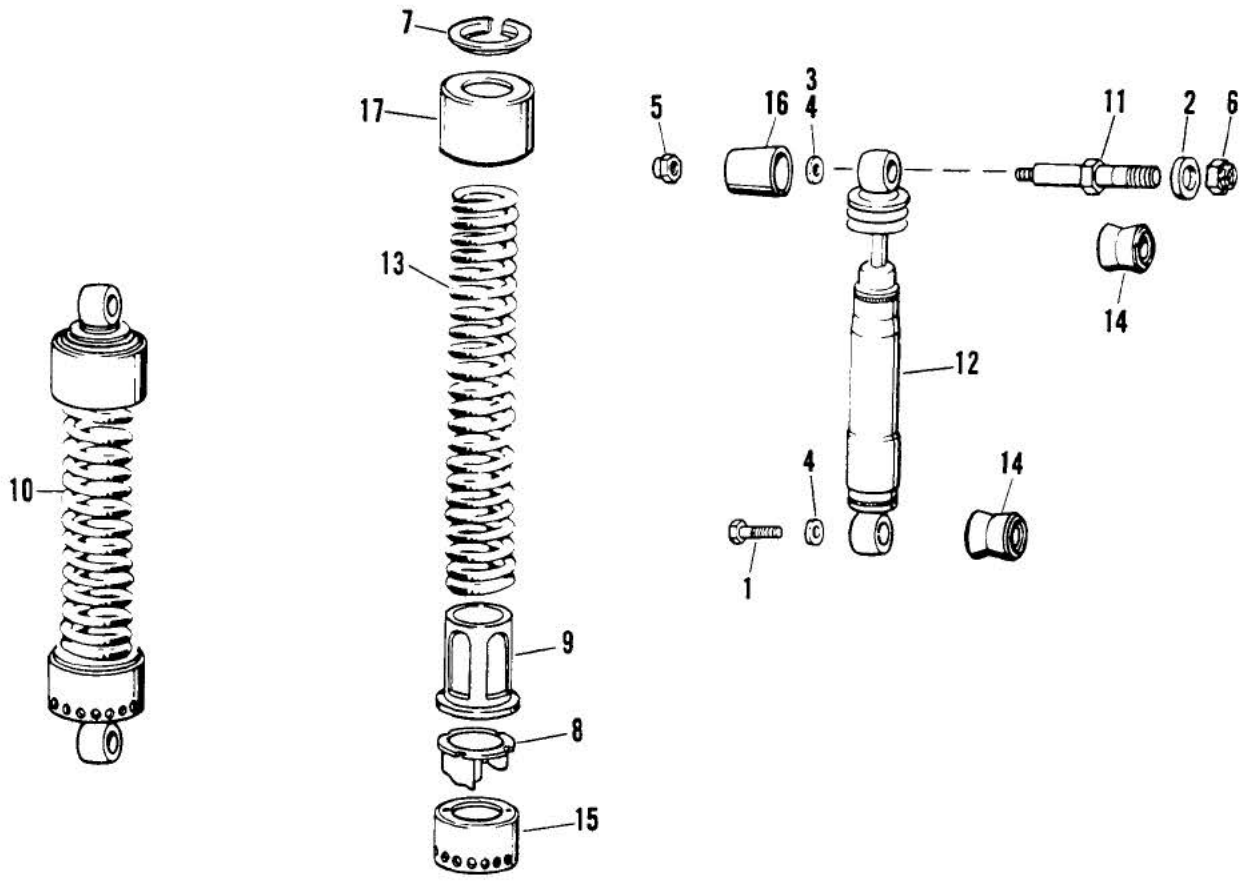

## SHOCK ABSORBERS — FXWG, FXSB, FXEF

FX31A

RETAIL PRICE	INDEX NO.	PART NO.	N A M E	USED ON
	1	3958	BOLT (2)	85 to * — FXWG, FXSB, FXEF
	2	5960W	SPACER, upper stud	85 to * — FXWG, FXSB, FXEF
	3	6701	WASHER (2)	Late 85 to * — FXWG, FXSB, FXEF
	4	6718	WASHER (4; 2 — Late 85 & Later)	85 to * — FXWG, FXSB, FXEF
	5	7628	NUT (2)	Late 85 to * — FXWG, FXSB, FXEF
		7775	LOCKNUT (2)	Early 85 — FXWG, FXSB, FXEF
	6	7993	LOCKNUT (2)	85 to * — FXWG, FXSB, FXEF
	7	54473-79	SEAT, spring — upper	85 to * — FXWG, FXSB, FXEF
	8	54474-79	ADJUSTER, spring	85 to * — FXWG, FXSB, FXEF
	9	54475-79	SPRING GUIDE, lower	85 to * — FXWG, FXSB, FXEF
	10	54509-73A	SHOCK ABSORBER, complete (chrome) (2)	85 to * — FXWG, FXSB, FXEF
		54515-73	UPPER STUD (2)	85 to * — FXWG, FXSB, FXEF
	12	54546-84	SHOCK ABSORBER, only (2)	85 to * — FXWG, FXSB, FXEF
	13	54555-84	SPRING, shock absorber (chrome) (2)	85 to * — FXWG, FXSB, FXEF
	14	54556-84	BUSHING (4)	85 to * — FXWG, FXSB, FXEF
	15	54569-84	CAM SLEEVE, shock absorber (2)	85 to * — FXWG, FXSB, FXEF
	16	54704-65	COVER, upper stud	85 to * — FXWG, FXSB, FXEF
	17	54710-84	COVER, shock absorber stud (2)	85 to * — FXWG, FXSB, FXEF

# HANDLEBAR

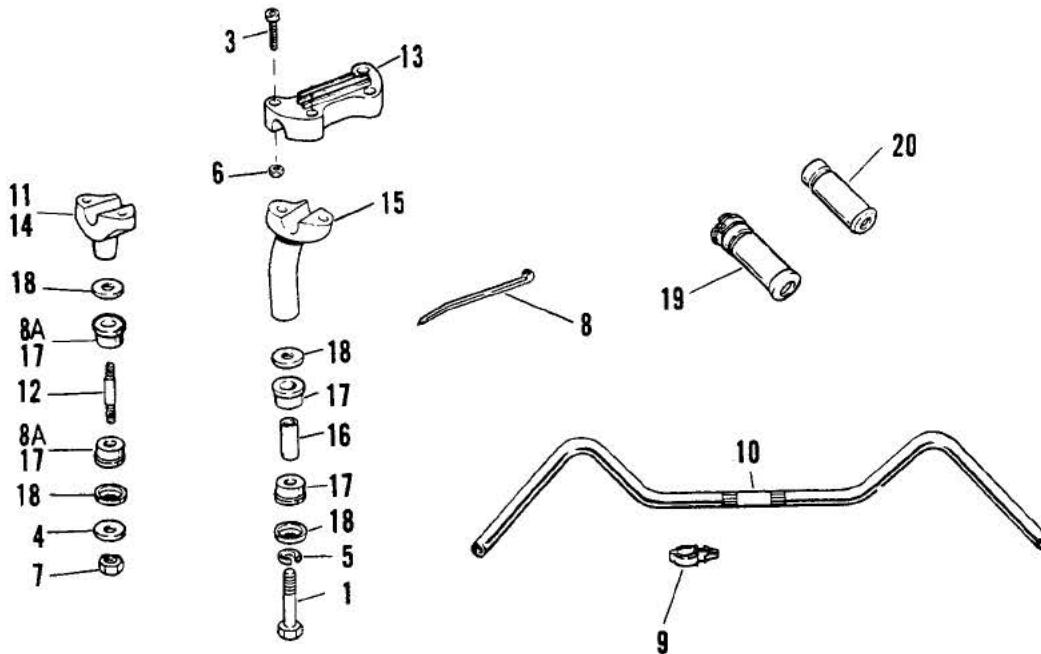

## HANDLEBAR

FX32

RETAIL PRICE	INDEX NO.	PART NO.	NAME	USED ON
	1	3450	BOLT (2) .....	85 to * — FXWG; Late 85 to * — FXST
		3471	BOLT (2) .....	84 & Early 85 — FXST
	3	4816	SCREW (4) .....	84 — FXST; 85 to * — All Models
	4	6718	WASHER, right .....	Early 85 — FXWG, FXSB, FXEF
	5	7068	LOCKWASHER (2) .....	84 to * — FXST; 85 to * — FXWG
	6	7740	LOCKNUT (4) .....	85 — FXSB, FXEF
	7	7768W	LOCKNUT (2) .....	85 — FXSB, FXEF
	8	10006	CABLE STRAP .....	84 — FXST
		10065	CABLE STRAP (2) .....	85 to * — FXST; 86 to * — FXWG
	8A	53156—86	BUSHING, handlebar mounting (rubber) (4) .....	86 to * — FXST
	9	56073—83	RETAINER (4) .....	84 — FXST; 85 to * — All Models
	10	56081—82	HANDLEBAR, buckhorn .....	84 — FXST; 85 to * — All Models
	11	56098—80	CLAMP, handlebar — lower right (riser) .....	85 to * — FXWG
		56099—80	CLAMP, handlebar — lower left (riser) .....	85 to * — FXWG
	12	56105—84	STUD, handlebar (2) .....	85 — FXSB, FXEF
	13	56115—79A	CLAMP, handlebar — upper .....	85 — FXSB, FXEF
		56119—77	CLAMP, handlebar — upper .....	84 to * — FXST; 85 to * — FXWG
	14	56116—82	CLAMP, handlebar — lower left .....	85 — FXSB, FXEF
		56117—82	CLAMP, handlebar — lower right .....	85 — FXSB, FXEF
	15	56122—77	CLAMP, handlebar — lower left (riser) .....	84 to * — FXST
		56124—77	CLAMP, handlebar — lower right (riser) .....	84 to * — FXST
	16	56153—73	SPACER, handlebar mounting (2) .....	84 to * — FXST; 85 to * — FXWG
	17	56158—73	BUSHING, handlebar mounting rubber (4) .....	84 & 85 — FXST; 85 to * — FXWG, FXSB, f
	18	56159—73	CUP WASHER, handlebar mounting (4) .....	84 — FXST; 85 to * — All Models
	19	56206—81A	HANDLEBAR GRIP, left .....	84 — FXST; 85 to * — All Models
	20	56220—81B	GRIP & SLEEVE, throttle .....	84 — FXST; 85 to * — All Models

# THROTTLE CONTROL

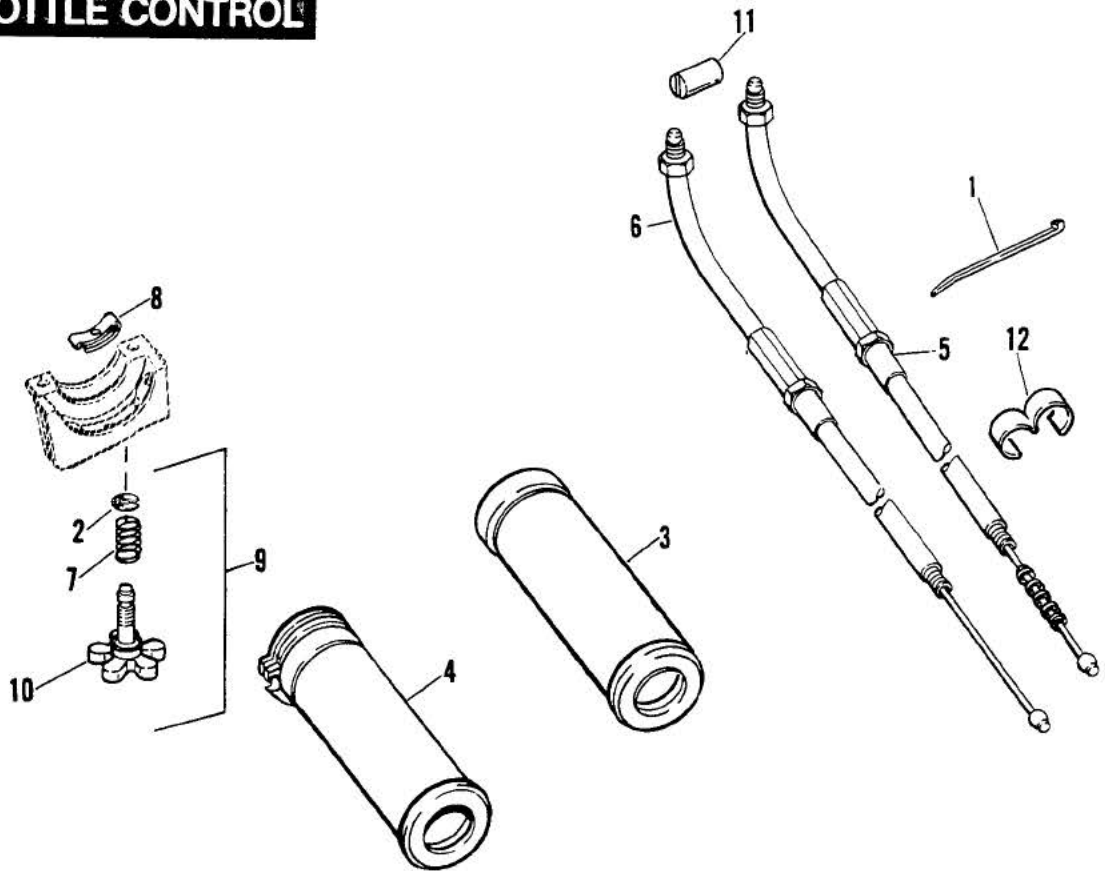

## THROTTLE CONTROL

FX33

RETAIL PRICE	INDEX NO.	PART NO.	NAME	USED ON
	1	10006	CABLE STRAP	Late 85 to * — All Models
	2	11155	RETAINING RING	84 — FXST; 85 to * — All Models
	3	56206—81A	HANDLEBAR GRIP	84 — FXST; 85 to * — All Models
	4	56220—81B	GRIP AND SLEEVE, throttle	84 — FXST; 85 to * — All Models
	5	56323—81C	IDLE CONTROL ASSEMBLY	84 — FXST; 85 to * — All Models
	6	56324—81C	THROTTLE CONTROL ASSEMBLY	84 — FXST; 85 to * — All Models
	7	56394—74	SPRING, throttle control clamp adjusting screw	84 — FXST; 85 to * — All Models
	8	56396—74A	FRICTION SPRING, throttle grip	84 — FXST; 85 to * — All Models
	9	56397—74C	ADJUSTING SCREW KIT, includes items 2, 7 & 10	84 — FXST; 85 — All Models
	10	56402—83A	ADJUSTING SCREW, only	84 — FXST; 85 to * — All Models
	11	56508—76	FERRULE, control wire — hand grip end (2)	84 — FXST; 85 to * — All Models
	12	70504—81	CLIP, throttle cables	84 — FXST; 85 to * — All Models

# FENDERS AND REAR CHAIN OR BELT GUARD — FXST

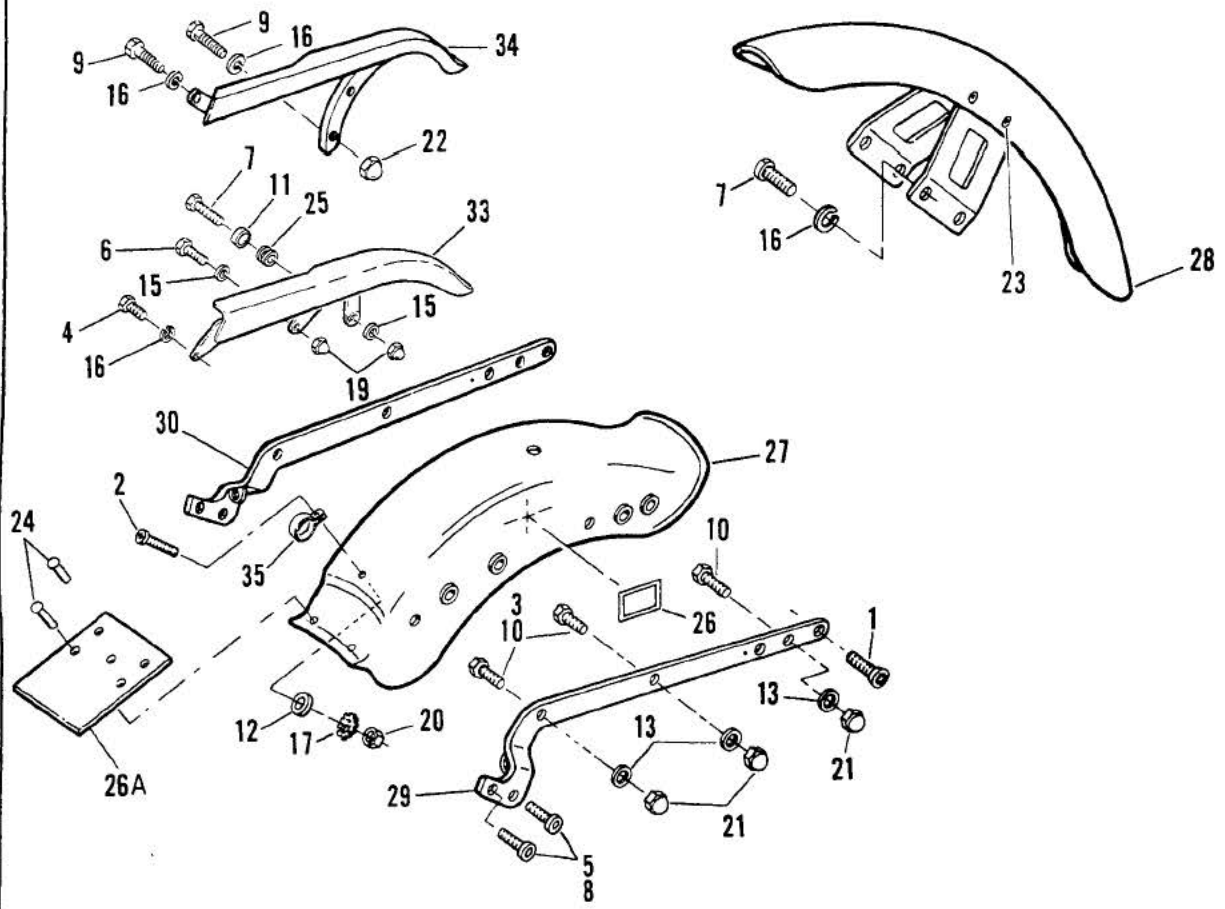

RETAIL PRICE	INDEX NO.	PART NO.	NAME	USED ON
	1	2005	SCREW (2)	84 to * — FXST
	2	2583	SCREW	84 & 85 — FXST
	3	2879W	BOLT (4)	84 & 85 — FXST
	4	2882W	BOLT	86 to * — FXST
	5	3569A	SCREW (4)	84 & 85 — FXST
	6	3987	BOLT	86 to * — FXST
	7	3991	BOLT (4; 5 — 86 & Later)	84 to * — FXST
	8	4013	SCREW (4)	86 to * — FXST
	9	4391	BOLT (3)	84 & 85 — FXST
	10	4716W	BOLT (2; 6 — 86 & Later)	84 to * — FXST
	11	5926B	SPACER	86 to * — FXST
	12	6029	WASHER	86 to * — FXST
	13	6379W	WASHER (6)	84 to * — FXST
	15	6702	WASHER (2)	86 to * — FXST
	16	7041	LOCKWASHER (7; 5 — 86 & Later)	84 to * — FXST
	17	7220	LOCKWASHER	84 & 85 — FXST
	19	7507	ACORN NUT (2)	86 to * — FXST
	20	7638	NUT	84 & 85 — FXST
	21	7680W	ACORN NUT (6)	84 to * — FXST
	22	7736	ACORN NUT (2)	84 & 85 — FXST
	23	8519	RIVET (4)	84 — FXST
	24	8692	POP RIVET (3)	86 to * — FXST
	25	11411	GROMMET	86 to * — FXST
	26	59255—72	REFLECTOR (red) (2)	84 to * — FXST
	26A	59648—84A	DEBRIS DEFLECTOR, upper	86 to * — FXST
	27	59914—84	REAR FENDER (prime)	84 & 85 — FXST
		59914—86A	REAR FENDER (prime)	86 to * — FXST
	28	59924—80	FRONT FENDER (prime)	84 to * — FXST
	29	59954—84	FENDER SUPPORT, left — rear	84 & 85 — FXST
		59954—86	FENDER SUPPORT, left — rear	86 to * — FXST
	30	59955—84	FENDER SUPPORT, right — rear	84 & 85 — FXST
		59955—86	FENDER SUPPORT, right — rear	86 to * — FXST
	33	60533—86	BELT GUARD, rear	86 to * — FXST
	34	60639—84	CHAIN GUARD, rear (chrome)	84 & 85 — FXST
	35	71795—63A	CLAMP, rear fender	84 to * — FXST



# FENDERS AND REAR CHAIN OR BELT GUARD — FXWG, FXSB, FXEF

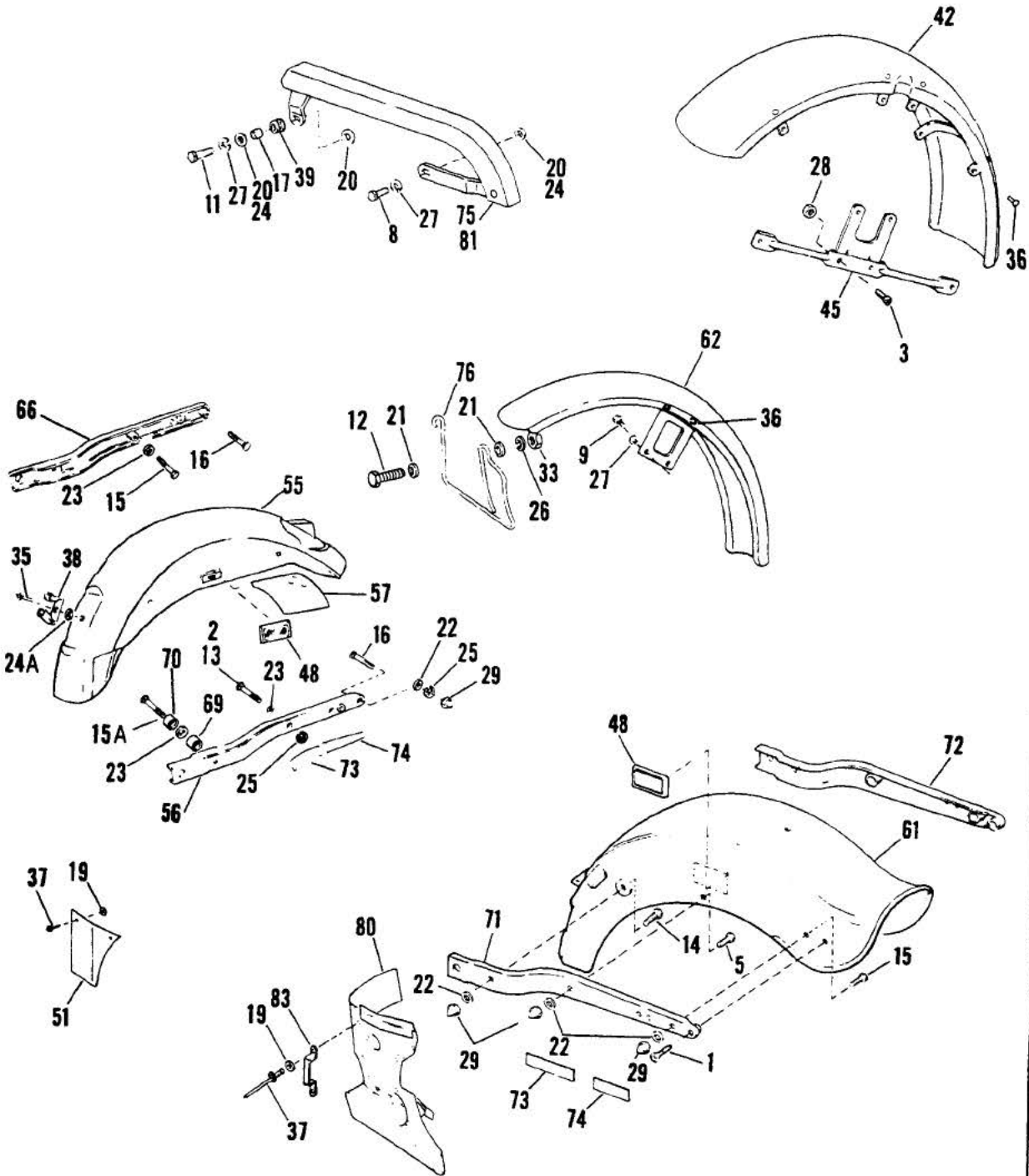

RETAIL PRICE	INDEX NO.	PART NO.	NAME	USED ON
			NOTE: For painted part numbers, refer to Dealer Accessory Guide.	
	1	2005	SCREW (2)	85 to * — FXWG
	2	2879W	BOLT	Early 85 — FXEF
		3003	BOLT	Late 85 — FXSB, FXEF
	3	3210	SCREW (4)	85 — FXSB, FXEF
	5	3443	BOLT (2)	85 to * — FXWG
	8	3974HW	BOLT	85 to * — FXWG
	9	3991	BOLT (4)	85 to * — FXWG
	11	4014W	BOLT	85 to * — FXWG, FXSB
		4036	BOLT	85 — FXEF
	12	4640	BOLT	85 — FXEF
	13	4716W	BOLT	Early 85 — FXSB
	14	4720W	BOLT (2)	85 to * — FXWG
	15	4721	BOLT (2 — FXWG)	85 to * — FXWG, FXSB, FXEF
	15A	4722	BOLT (2)	85 — FXSB, FXEF
	16	5423	CARRIAGE BOLT	85 — FXSB, FXEF
	17	5926B	SPACER, chain guard	85 to * — FXWG, FXSB, FXEF
	19	6029	WASHER (6)	85 to * — FXWG, FXSB
	20	6107B	WASHER (2)	85 to * — FXWG, FXSB, FXEF
		6333	WASHER (2)	85 — FXEF
	21	6334	WASHER (2)	85 — FXEF
	22	6379W	WASHER (6)	85 to * — FXWG, FXSB, FXEF
	23	6701	WASHER (3)	85 — FXSB, FXEF
	24	6702	WASHER	85 to * — FXWG, FXSB, FXEF
	24A	6716	WASHER (3)	Late 85 — FXSB, FXEF
	25	7038	LOCKWASHER (4)	Late 85 — FXSB, FXEF
	26	7039	LOCKWASHER	85 — FXEF
	27	7041	LOCKWASHER (2; 6 — FXWG)	85 to * — FXWG, FXSB, FXEF
	28	7531	LOCKNUT, flange (4)	85 — FXSB, FXEF
	29	7680W	ACORN NUT (6)	85 to * — FXWG, FXSB, FXEF
	33	7848W	JAM NUT	85 — FXEF
	35	8483	POP RIVET (3)	85 — FXSB, FXEF
	36	8519	RIVET, fender support (8; 4 — FXWG)	85 to * — FXWG, FXSB, FXEF
	37	8692	POP RIVET (6)	85 to * — FXWG, FXSB
	38	9952	CIRCUIT BREAKER CLIP (3)	85 — FXSB, FXEF
	39	11411	GROMMET, chain guard	85 to * — FXWG, FXSB, FXEF
	42	59007—84	FRONT FENDER (prime)	85 — FXSB, FXEF
	45	59111—74	FENDER BRACE, front fender (2)	85 — FXSB, FXEF
	48	59255—72	REFLECTOR (red) (2)	85 to * — FXWG, FXSB, FXEF
	51	59646—80	FENDER DEBRIS DEFLECTOR	85 to * — FXWG
	55	59682—78	REAR FENDER, low seat, turn signals (prime)	85 — FXSB, FXEF
	56	59686—78	SUPPORT, turn signal — left rear	85 — FXSB, FXEF
	57	59687—84	VIBRATION DAMPENER	85 — FXEF
	61	59904—84	REAR FENDER (prime)	85 to * — FXWG
	62	59924—80	FRONT FENDER (prime)	85 to * — FXWG
	66	59929—73	SUPPORT, turn signal — right rear	85 — FXSB, FXEF
	69	59939—84	SPACER (2)	85 — FXSB, FXEF
	70	59945—84	WASHER (2)	85 — FXSB, FXEF
	71	59960—80	SUPPORT, rear fender — left (chrome)	85 to * — FXWG
	72	59961—80	SUPPORT, rear fender — right (chrome)	85 to * — FXWG
	73	59962—80	TRIM, rear fender support — front (2)	85 to * — FXWG, FXSB
	74	59963—80	TRIM, rear fender support — rear (2)	85 to * — FXWG, FXSB
	75	60302—78	REAR CHAIN GUARD (black)	85 — FXEF
	76	60303—84	DEBRIS DEFLECTOR	N/A 85 — FXEF
	80	60386—84	DEBRIS DEFLECTOR	85 to * — FXWG, FXSB
	81	60388—82	BELT GUARD, rear (black)	85 to * — FXWG, FXSB
	83	60494—80	BRACKET, debris deflector (2)	85 to * — FXWG, FXSB

# LICENSE PLATE BRACKETS

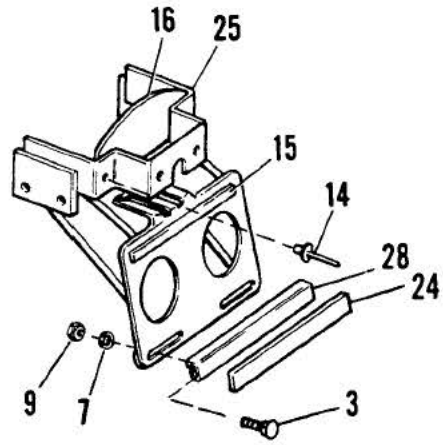
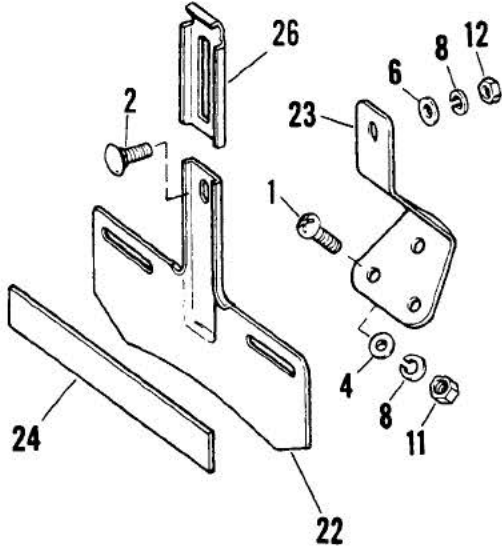

RETAIL PRICE	INDEX NO.	PART NO.	N A M E	USED ON
	1	2602	SCREW (3) .....	85 — FXEF
		2774	SCREW (3) .....	85 — FXSB
	2	5403B	CARRIAGE BOLT .....	85 — FXSB, FXEF
	3	5465	CARRIAGE BOLT (2) .....	84 to * — FXST; 85 to * — FXWG
	4	6235	WASHER (3) .....	85 — FXEF
	6	6703	WASHER (4) .....	85 — FXSB
	7	6716	WASHER (2) .....	84 to * — FXST; 85 to * — FXWG
	8	7036	LOCKWASHER (4) .....	85 — FXSB
	9	7624	NUT (2) .....	84 to * — FXST; 85 to * — FXWG
	11	7686	LOCKNUT (3) .....	85 — FXEF
		7688	NUT (3) .....	85 — FXSB
	12	7689W	JAMNUT .....	85 — FXSB, FXEF
	14	8483	POP RIVET (2) .....	84 to * — FXST; 85 to * — FXWG
	15	52092—77	FOAM TAPE .....	84 to * — FXST; 85 to * — FXWG
	16	59971—80	SPLASH SHIELD, rubber .....	84 to * — FXST; 85 to * — FXWG
		59983—75	BRACKET ASSEMBLY, license plate — consists of items 2, 6, 8, 12, 22-24 & 26 .....	85 — FXSB, FXEF
	22	59984—73	BRACKET, license plate .....	85 — FXSB, FXEF
	23	59986—75	SUPPORT, license plate bracket .....	85 — FXSB, FXEF
	24	59988—72	REFLECTOR, license plate bracket .....	84 to * — FXST; 85 to * — FXWG
	25	59993—80A	LICENSE PLATE ASSEMBLY .....	84 to * — FXST; 85 to * — FXWG
	26	60001—55	CLAMP, license plate .....	85 — FXSB, FXEF
	28	60005—77	CLAMP, license plate .....	84 to * — FXST; 85 to * — FXWG

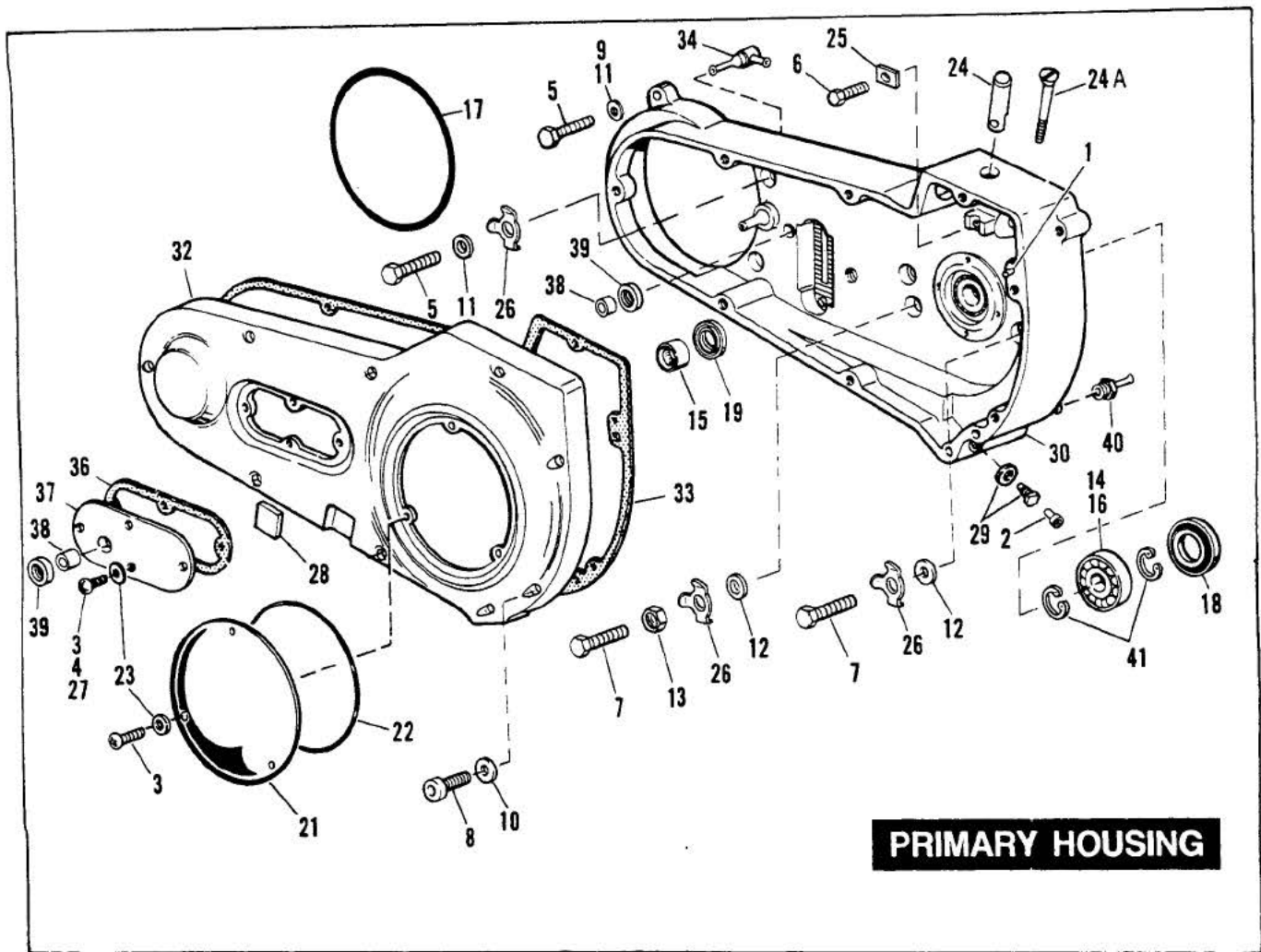

RETAIL PRICE	INDEX NO.	PART NO.	NAME	USED ON
	1	334A	ROLL PIN, primary housing	84 — FXST; 85 to * — All Models
		375	ROLL PIN, primary housing	86 to * — FXST
	2	739	MAGNETIC PLUG	86 to * — FXST
	3	924	SCREW (7)	85 to * — All Models
		2337W	SCREW (w/lock patch) (3; 7 — 86 & Later)	84 — FXST
	4	2356	SCREW (4)	84 — FXST
	5	2871W	BOLT (4)	86 to * — FXST
	6	3545	BOLT	86 to * — FXST
		4017	BOLT (2)	84 — FXST; 85 to * — All Models
		4021	BOLT (w/safety wire holes) (2)	84 — FXST; 85 to * — All Models
	7	4068	BOLT (4)	86 to * — FXST
		4720W	BOLT (2)	84 & 85 — FXST; 85 — FXEF
		4722	BOLT (2)	85 to * — FXWG, FXSB
	8	4813	SCREW (9)	84 — FXST; 85 to * — All Models
	9	6016	WASHER (2)	86 to * — FXST
	10	6099	WASHER (9)	84 — FXST; 85 to * — All Models
	11	6324W	WASHER (4)	84 — FXST; 85 to * — All Models
	12	6388HB	WASHER (4)	84 — FXST; 85 to * — All Models
	13	7775	LOCKNUT (2)	84 — FXST; 85 to * — All Models
	14	9061	BALL BEARING, primary housing	Early 84 — FXST
	15	9063	NEEDLE BEARING	84 — FXST; 85 to * — All Models
	16	9135	ROLLER BEARING, primary housing	Late 84 — FXST; 85 to * — All Models
	17	11147	O-RING, primary housing cover	84 — FXST; 85 to * — All Models
	18	12018	OIL SEAL	Early 84 — FXST
		12052	OIL SEAL	Late 84 — FXST; 85 to * — All Models
	19	12051	OIL SEAL	86 to * — FXST
	21	25414—70A	COVER, clutch	84 — FXST; 85 to * — All Models
	22	25416—70	GASKET, chain & clutch cover	Early 84 — FXST
		25416—84	O-RING, chain & clutch cover	Late 84 — FXST; 85 to * — All Models
	23	31433—84A	WASHER, clutch cover (3; 7 — 86 & Later)	Late 84 — FXST; 85 to * — FXWG, FXST
	24	31473—86	PIVOT SHAFT, actuator	86 to * — FXST
	24A	31478—65A	TOP SCREW, primary housing	84 — FXST; 85 to * — All Models
	25	31474—86	LOCK PLATE	86 to * — FXST
	26	33318—85	LOCKTAB (6)	86 to * — FXST
	27	41191—74	SCREW (4)	85 to * — FXWG
	28	50100—70	BUMPER, jiffy stand	84 — FXST; 85 to * — All Models
	29	60348—65A	MAGNETIC DRAIN PLUG AND WASHER	84 — FXST; 85 to * — All Models
	30	60414—84	PRIMARY HOUSING — rear chain	85 to * — FXWG
		60421—84	PRIMARY HOUSING — rear chain	85 — FXEF
		60441—82A	PRIMARY HOUSING — rear chain (polished)	Early 84 — FXST
		60441—84	PRIMARY HOUSING — rear chain (polished)	Late 84 & 85 — FXST
		60441—86A	PRIMARY HOUSING — rear belt (polished)	86 to * — FXST
		60504—84	PRIMARY HOUSING — rear chain	85 — FXSB
	32	60507—82A	COVER, primary housing — rear chain (w/9063 BEARING)	84 & 85 — FXST; 85 — FXEF
		60507—86A	COVER, primary housing — rear belt (w/9063 BEARING)	86 to * — FXST
		60531—83B	COVER, primary housing — rear belt (w/9063 BEARING)	85 to * — FXWG, FXSB
	33	60538—81D	GASKET, housing cover	84 — FXST; 85 to * — FXWG
		60539—86	GASKET, housing cover	86 to * — FXST
	34	60549—70	CHAIN OILER FITTING, primary housing	Early 84 — FXST
	36	60567—65B	GASKET, inspection cover	84 to * — FXST; 85 to * — FXWG
	37	60572—78A	INSPECTION COVER, w/screw & washer (chrome)	84 & 85 — FXST; 85 — FXWG
		60572—86	INSPECTION COVER	84 to * — FXST; 85 to * — FXWG
		60579—74	INSPECTION COVER, w/bushing & seal (chrome)	85 — FXSB, FXEF
	38	60593—74	BUSHING, shifter shaft (2)	85 — FXSB, FXEF
	39	60641—74	OIL SEAL, shifter shaft (2)	85 — FXSB, FXEF
	40	63533—41	FITTING, vent hose	Early 84 — FXST
	41	60678—85	RETAINING RING (2)	86 to * — FXST



RETAIL PRICE	INDEX NO.	PART NO.	NAME	USED ON
	1	923	SCREW	85 — FXSB, FXEF
		924	SCREW	Late 84 to * — FXST; 85 to * — FXWG
		2773	SCREW	Early 84 — FXST
	2	3409	BOLT (2 — FXWG, FXST)	84 — FXST; 85 to * — All Models
	3	3987	BOLT (2)	84 — FXST; 85 to * — All Models
	4	4014W	BOLT (2)	84 — FXST; 85 to * — All Models
	5	4092	SCREW (2)	85 — FXSB, FXEF
	7	5775	SPACER (2)	84 — FXST; 85 to * — All Models
	8	6237	WASHER (6)	84 — FXST; 85 to * — All Models
	9	6365	WASHER (4)	84 — FXST; 85 to * — All Models
	10	6702	WASHER (2)	85 — FXSB, FXEF
	11	7041	LOCKWASHER (4)	84 — FXST; 85 to * — All Models
	12	7127	LOCKWASHER (2)	85 — FXSB, FXEF
	13	7725	LOCKNUT (2 — FXWG, FXST)	84 — FXST; 85 to * — All Models
	14	8108	SPEED NUT	84 — FXST; 85 to * — All Models
	15	10014	CLAMP, fuel hose (3)	84 — FXST; 85 to * — All Models
	16	11447	GROMMET, fuel tank mounting (6)	84 — FXST; 85 to * — All Models
	17	14061—84	TRIM, tank side — right (gold, brown & black)	85 — FXEF
		14062—84	TRIM, tank side — left (gold, brown & black)	85 — FXEF
		14063—84	TRIM, tank side — right (silver, grey & black)	85 — FXEF
		14064—84	TRIM, tank side — left (silver, grey & black)	85 — FXEF
	18	14072—84	TRIM, tank side — right (gold & black)	84 — FXST; 85 — FXSB
		14073—84	TRIM, tank side — left (gold & black)	84 — FXST; 85 — FXSB
	19	14123—86	DECAL, tank side (red & slate grey) (2)	86 to * — FXST
		14124—86	DECAL, tank side (silver & black) (2)	86 to * — FXST
		14125—86	DECAL, tank side (gold & black) (2)	86 to * — FXST
	20	61102—83A	CAP, fuel filler — right (vented)	84 — FXST; 85 to * — All Models
	21	61103—83	CAP, fuel filler — left	84 — FXST; 85 to * — All Models
	22	61109—85	GASKET (2)	84 — FXST; 85 to * — All Models
	23	61155—84	TRIM, fuel tank	84 to * — FXST
		61161—85	TRIM, fuel tank	85 to * — FXWG
	24	61160—80	DECAL, tank side (gold & black) (2)	86 to * — FXWG
	25	61211—84B	FUEL TANK, left — 5 gal. (prime)	84 to * — FXST; 85 to * — FXWG
		61218—85A	FUEL TANK, right — 3-1/2 gal. (prime)	85 — FXSB, FXEF
	26	61228—84	FUEL TANK, left — 5 gal. (prime)	84 to * — FXST; 85 to * — FXWG
		61426—85	FUEL TANK, left — 3-1/2 gal. (prime)	85 — FXSB, FXEF
	27	61640—84	FOAM STRIP (2)	Late 84 to * — FXST; 85 to * — FXWG
	28	61641—84	SPACER, trim	84 to * — FXST; 85 to * — FXWG
	29	61647—85	TRIM, fuel tank	85 — FXSB, FXEF
	30	61648—85A	EDGING, trim panel	85 — FXSB, FXEF
	31	61660—85	BRACKET, fuel tank mounting — upper	85 — FXSB, FXEF
		61661—84	BRACKET, fuel tank mounting — upper	84 to * — FXST; 85 to * — FXWG
	32	61667—84	BRACKET, fuel tank mounting — lower	84 — FXST; 85 to * — All Models
	33	62161—75	NUT, fuel valve	84 — FXST; 85 to * — All Models
	34	62166—81	FILTER, fuel valve	84 — FXST; 85 to * — All Models
	35	62167—81	FUEL VALVE, only	84 — FXST; 85 to * — All Models
	36	62172—75	GASKET, fuel valve	84 — FXST; 85 to * — All Models

NOTE: Hose or insulator is sold only in bulk length under the following part numbers. Cut to required length.

39	63501—68	HOSE, 1/4 I.D. x 1/2 O.D., reinforced rubber (25 ft. lg.)	84 — FXST; 85 to * — All Models
40	63505—84	INSULATOR, 1/2 I.D. (nylon) (8 ft. lg.)	84 — FXST; 85 to * — All Models



# OIL TANK, FILTER AND BATTERY — FXST

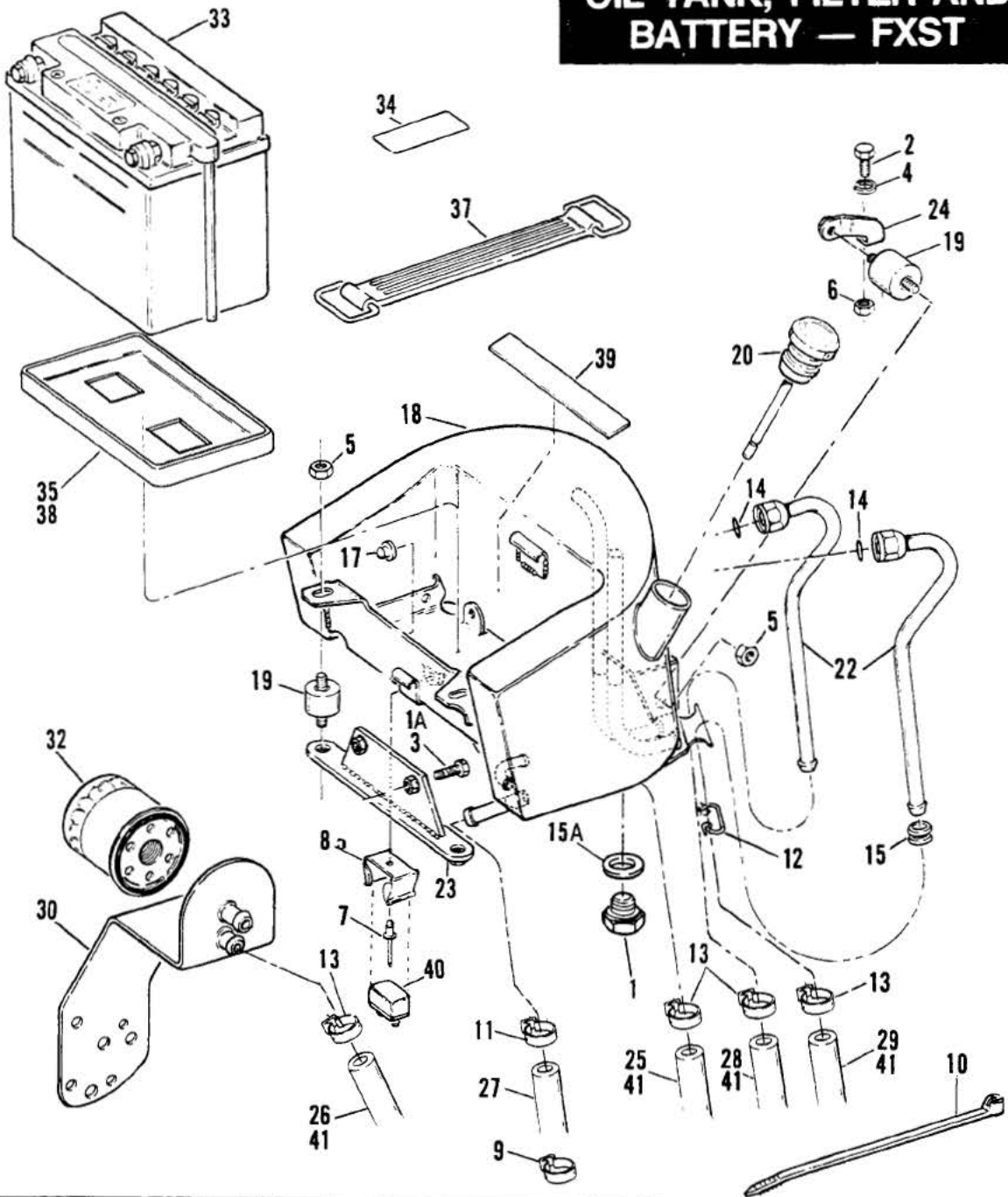

RETAIL PRICE	INDEX NO.	PART NO.	NAME	USED ON
	1	706A	DRAIN PLUG .....	84 & 85 — FXST
	1A	3974HW	BOLT (2) .....	86 to * — FXST
	2	3987	BOLT .....	84 to * — FXST
	3	4391	BOLT (2) .....	84 & 85 — FXST
	4	7041	LOCKWASHER .....	84 to * — FXST
	5	7686	LOCKNUT (8; 5 — 85 & Later) .....	84 to * — FXST
	6	7748W	NUT .....	84 to * — FXST
	7	8483	POP RIVET .....	84 — FXST
		8672	POP RIVET .....	Late 85 to * — FXST
	8	9952	CLIP, circuit breaker .....	84 to * — FXST
	9	9969	CLAMP .....	86 to * — FXST
	10	10006	CABLE STRAP .....	86 to * — FXST
	11	10049	CLAMP (2) .....	86 to * — FXST
	12	10079	CLIP, oil line .....	Late 85 — FXST
	13	10080	CLAMP (6 — 84 & 85; 8 — 86 & Later) .....	84 to * — FXST
	14	11159	O-RING, oil tank fittings (2) .....	84 & 85 — FXST
	15	11446	GROMMET, oil tank fittings (2) .....	N/A 84 & Early 85 — FXST
	15A	26231—78	WASHER, drain plug .....	84 & 85 — FXST
	17	60319—83	RUBBER MOUNT, battery (6) .....	84 & Early 85 — FXST
	18	62498—84C	OIL TANK (external oil lines) .....	84 & 85 — FXST
		62498—86A	OIL TANK .....	86 to * — FXST
	19	62563—65	RUBBER MOUNT, oil tank (4) .....	84 to * — FXST
	20	62634—84	FILLER CAP, with dipstick .....	84 to * — FXST
	22	62703—84	OIL LINES, with fittings & O-rings (2) .....	84 & Early 85 — FXST
		62703—85	OIL LINES, with fittings & O-rings (2) .....	Late 85 — FXST
	23	62704—84	BRACKET, oil tank — rear .....	84 to * — FXST
	24	62707—84	BRACKET, oil tank to frame — front .....	84 to * — FXST
	25	63515—86	HOSE, tank to pump inlet .....	86 to * — FXST
	26	63531—84	HOSE, pump to filter inlet .....	N/A 86 to * — FXST
	27	63553—86	HOSE, tank drain .....	86 to * — FXST
	28	63556—86	HOSE, filter to tank inlet .....	86 to * — FXST
	29	63572—86	HOSE, tank vent .....	86 to * — FXST
	30	63802—84A	BRACKET, oil filter .....	84 to * — FXST
	32	63805—80A	OIL FILTER (black) .....	84 to * — FXST
	33	65991—82A	BATTERY, 12 V .....	84 to * — FXST
	34	66047—80A	DECAL, oil tank "WARNING" .....	84 to * — FXST
	35	66103—74A	CUSHION, battery .....	84 & Early 85 — FXST
	37	66105—77	BATTERY STRAP .....	84 to * — FXST
	38	66210—85	CUSHION, battery .....	Late 85 to * — FXST
	39	66309—84	CUSHION, battery (2) .....	84 to * — FXST
	40	74599—77A	CIRCUIT BREAKER .....	84 to * — FXST

NOTE: Hose is sold only in bulk length under the following part number. Cut to required length.

41	63500—68	HOSE, 3/8 I.D. x 5/8 O.D., reinforced rubber (25 ft. lg.)	84 & 85 — FXST
----	----------	---	----------------

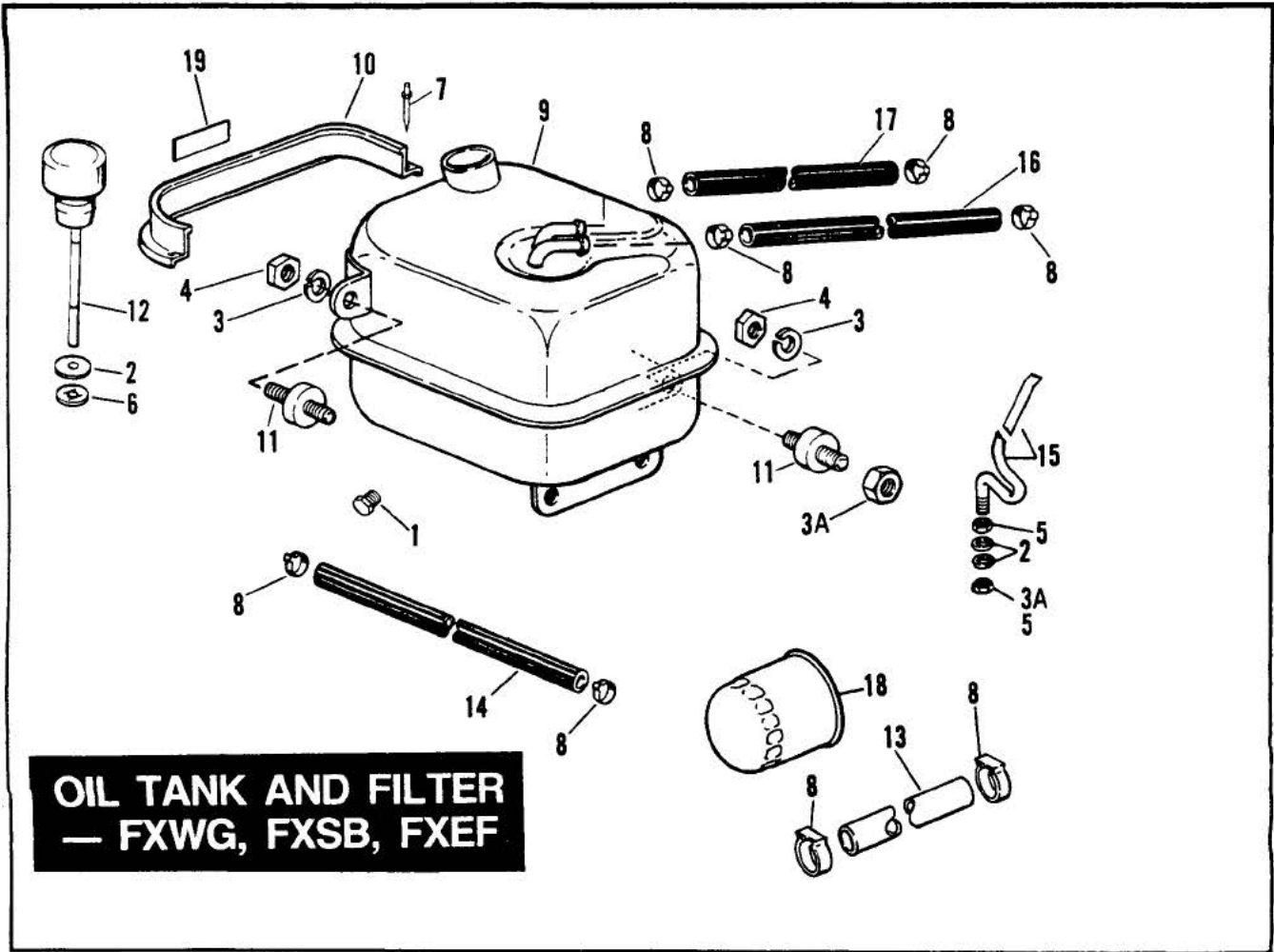

**OIL TANK AND FILTER — FXWG, FXSB, FXEF**

**FX38A**

RETAIL PRICE	INDEX NO.	PART NO.	NAME	USED ON
	1	706A	DRAIN PLUG .....	85 to * — FXWG, FXSB, FXEF
	2	6703	WASHER (3) .....	85 to * — FXWG, FXSB, FXEF
	3	7036	LOCKWASHER (2) .....	85 to * — FXWG, FXSB, FXEF
	3A	7686	LOCKNUT (2 — Late 85 & Later) .....	85 to * — FXWG, FXSB, FXEF
	4	7688	NUT (2) .....	85 to * — FXWG, FXSB, FXEF
	5	7689W	JAM NUT (2 — Early 85) .....	85 to * — FXWG, FXSB, FXEF
	6	8126	SPEED NUT, oil cap .....	85 to * — FXWG, FXSB, FXEF
	7	8698	POP RIVET (2) .....	85 to * — FXWG, FXSB, FXEF
	8	10080	CLAMP, oil hoses (8) .....	85 — FXSB, FXEF; 85 to * — FXWG
	9	62504—82A	OIL TANK .....	85 to * — FXWG, FXSB, FXEF
	10	62534—65	EDGING, oil tank (without "H" decal) .....	85 to * — FXWG, FXSB, FXEF
	11	62563—65	RUBBER MOUNT (2) .....	85 to * — FXWG, FXSB, FXEF
	12	62625—70A	FILLER CAP, with dipstick .....	85 to * — FXWG, FXSB, FXEF
	13	63536—84	HOSE, oil pump to oil filter .....	N/A 85 to * — FXWG, FXSB, FXEF
	14	63539—84	HOSE, oil tank to oil pump .....	N/A 85 to * — FXWG, FXSB, FXEF
	15	63549—65A	BRACKET KIT, oil hose, includes index nos. 2 & 5 .....	85 to * — FXWG, FXSB, FXEF
	16	63564—84	HOSE, crankcase to oil tank vent .....	N/A 85 to * — FXWG, FXSB, FXEF
	17	63587—84	HOSE, oil filter to oil tank .....	N/A 85 to * — FXWG, FXSB, FXEF
	18	63810—80A	OIL FILTER .....	85 to * — FXWG, FXSB, FXEF
	19	66047—80A	DECAL, oil tank — "WARNING" .....	85 to * — FXWG, FXSB, FXEF

# EXHAUST SYSTEM

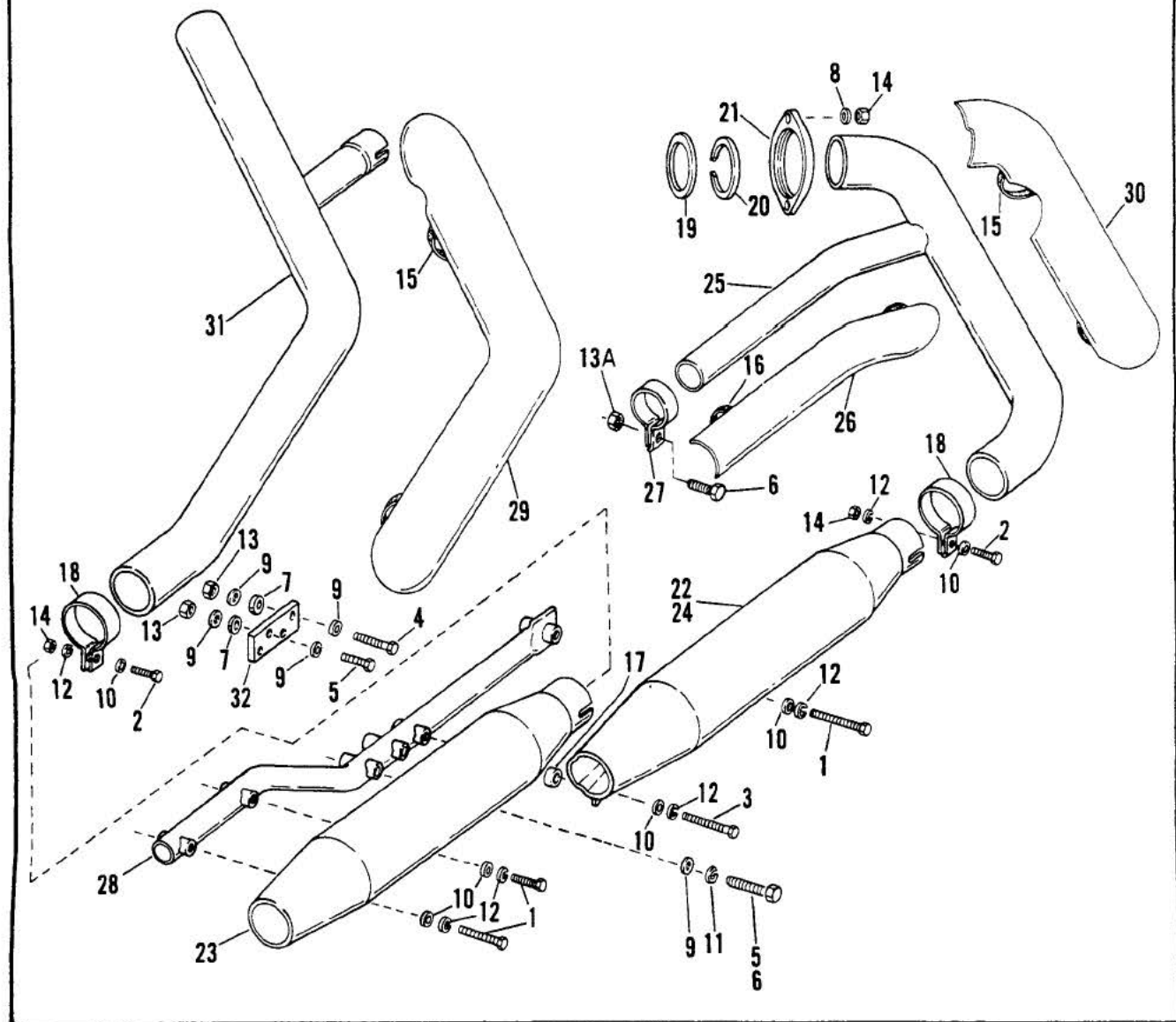

RETAIL PRICE	INDEX NO.	PART NO.	NAME	USED ON
	1	3987	BOLT (2)	84 — FXST; 85 to * — All Models
	2	4036	BOLT (2)	84 — FXST; 85 to * — All Models
	3	4017	BOLT (2)	84 — FXST; 85 to * — All Models
	4	4420	BOLT	85 to * — FXWG, FXSB, FXEF
	5	4719W	BOLT (3)	85 to * — FXWG, FXSB, FXEF
		4722	BOLT (2)	84 to * — FXST
	13	7633	NUT (2)	85 to * — FXWG, FXSB, FXEF
	13A	7748W	BOLT	85 to * — All Models
	14	7753	NUT (6)	84 — FXST; 85 to * — All Models
	15	9955	CLAMP (4)	84 — FXST; 85 to * — All Models
	16	10048	CLAMP, crossover shield (2)	84 — FXST; 85 to * — All Models
	17	52103—31	SPACER (2)	84 — FXST; 85 to * — All Models
	18	65276—62	CLAMP, muffler (2)	84 — FXST; 85 to * — All Models
	19	65324—83	GASKET, exhaust port (2)	84 — FXST; 85 to * — All Models
	20	65325—83	RETAINING RING, exhaust gasket (2)	84 — FXST; 85 to * — All Models
	21	65328—83	CLAMP, exhaust pipe to manifold (2)	84 — FXST; 85 to * — All Models
	22	65347—85	MUFFLER, front	85 — FXSB, FXEF
	23	65380—84	MUFFLER, rear	84 — FXST
		65380—85	MUFFLER, rear	85 to * — All Models
		65382—86	REAR MUFFLER (HDI part only)	86 to * — FXST
	24	65383—84	MUFFLER, front	N/A 84 — FXST
		65383—85	MUFFLER, front	85 to * — FXWG, FXST
		65395—86	FRONT MUFFLER (HDI part only)	86 to * — FXST
	25	65401—84	EXHAUST PIPE, front	84 & 85 — FXST; 85 & Early 86 — FXWG, FXSB, FXEF
		65401—86	EXHAUST PIPE, front	86 to * — FXST; Late 86 — FXWG
	26	65410—83	SHIELD, crossover (chrome)	84 — FXST; 85 to * — All Models
	27	65411—80A	CLAMP, crossover	84 — FXST; 85 to * — All Models
	28	65459—84	SUPPORT, muffler mounting	84 — FXST; 85 to * — All Models
	29	65481—83A	SHIELD KIT, rear exhaust — w/clamps (chrome)	84 & 85 — FXST; 85 & Early 86 — FXWG, FXSB, FXEF
		65702—86	SHIELD, front exhaust (chrome)	86 to * — FXST; Late 86 — FXWG
	30	65482—83	SHIELD KIT, front exhaust — w/clamps (chrome)	84 & 85 — FXST; 85 & Early 86 — FXWG, FXSB, FXEF
		65732—86	SHIELD, front exhaust (chrome)	86 to * — FXST; Late 86 — FXWG
	31	65603—84	EXHAUST PIPE, rear	84 & 85 — FXST; 85 & Early 86 — FXWG, FXSB, FXEF
		65603—86	EXHAUST PIPE, rear	86 to * — FXST; Late 86 — FXWG
	32	65774—85A	MOUNTING PLATE	85 to * — FXWG, FXSB, FXEF

# BATTERY — FXWG, FXSB, FXEF

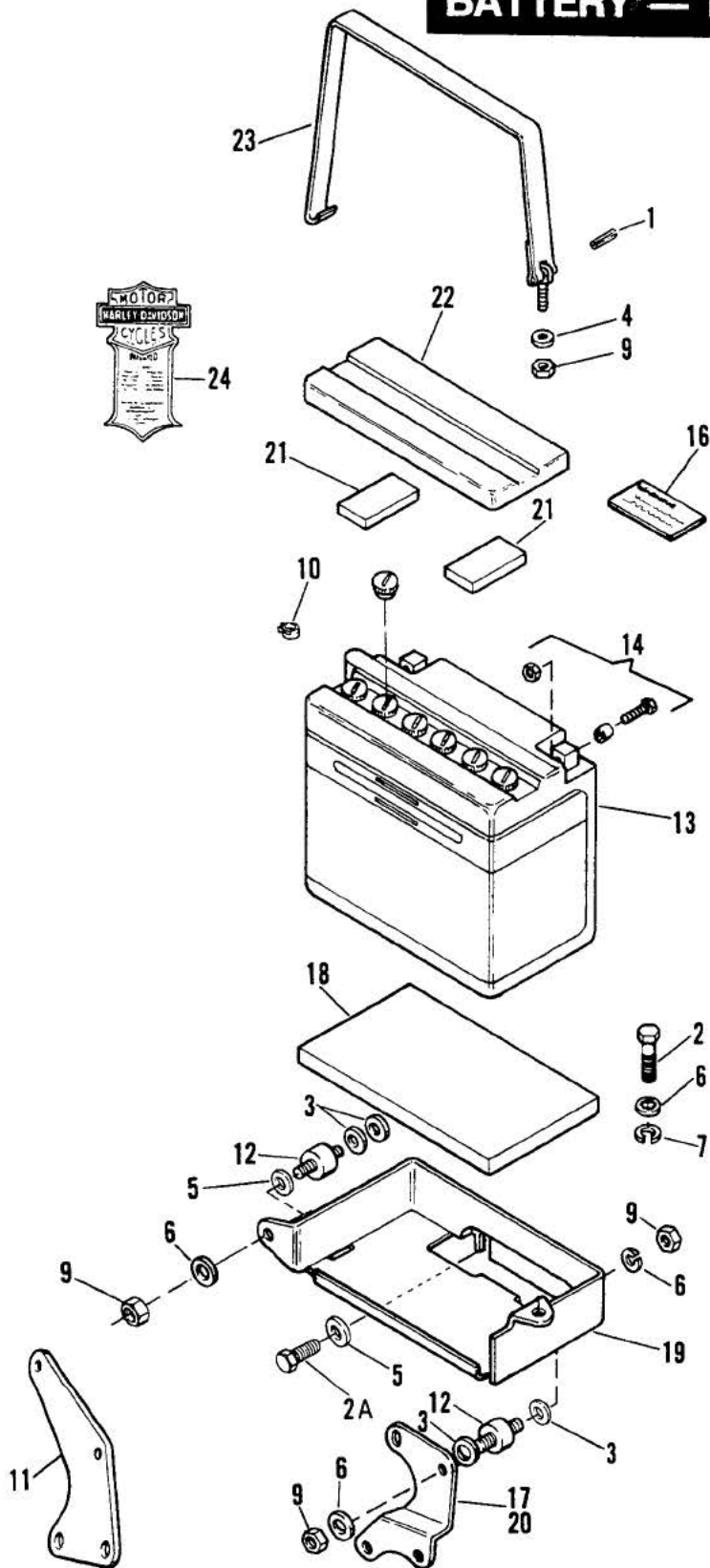

RETAIL PRICE	INDEX NO.	PART NO.	NAME	USED ON
	1	618	PIN .....	85 to * — FXWG, FXSB, FXEF
	2	3787	BOLT .....	85 to * — FXWG, FXSB, FXEF
	2A	4391	BOLT (2) .....	85 to * — FXWG, FXSB, FXEF
	3	6107B	WASHER (3; 4 — Late 85 & Later) .....	85 to * — FXWG, FXSB, FXEF
	4	6220W	WASHER .....	85 to * — FXWG, FXSB, FXEF
	5	6702	WASHER (2; 3 — Late 85 & Later) .....	85 to * — FXWG, FXSB, FXEF
	6	7036	LOCKWASHER (4) .....	85 to * — FXWG, FXSB, FXEF
	7	7229W	LOCKWASHER .....	85 to * — FXWG, FXSB, FXEF
	9	7688	NUT (4) .....	85 to * — FXWG, FXSB, FXEF
	10	10067	CLAMP, vent tube .....	85 to * — FXWG, FXSB, FXEF
	11	42527—82	MOUNTING BRACKET, brake fluid reservoir .....	85 to * — FXWG, FXSB, FXEF
	12	62563—65	RUBBER MOUNT, battery carrier (2) .....	85 to * — FXWG, FXSB, FXEF
	13	65991—82A	BATTERY — 12 V .....	85 to * — FXWG, FXSB, FXEF
	14	66000—80	TERMINAL KIT .....	85 to * — FXWG, FXSB, FXEF
	16	66047—80A	WARNING LABEL .....	85 to * — FXWG, FXSB, FXEF
	17	66099—80	BRACKET, battery carrier .....	85 to * — FXWG, FXSB, FXEF
	18	66103—74A	PAD, battery .....	85 to * — FXWG, FXSB, FXEF
	19	66191—80	CARRIER, battery .....	85 to * — FXWG, FXSB, FXEF
	20	66225—78	BRACKET, battery carrier .....	85 — FXEF
	21	66352—65	CUSHION, battery cover (2) .....	85 to * — FXWG, FXSB, FXEF
	22	66359—80	COVER, battery — with cushions (black) .....	85 — FXEF
		66367—73	COVER, battery — with cushions (chrome) .....	85 to * — FXWG, FXSB
	23	66476—73A	STRAP, battery cover .....	85 to * — FXWG, FXSB, FXEF
	24	99353—82Z	TRIM, battery .....	85 to * — FXWG, FXSB



# HEADLAMP — FXWG, FXST

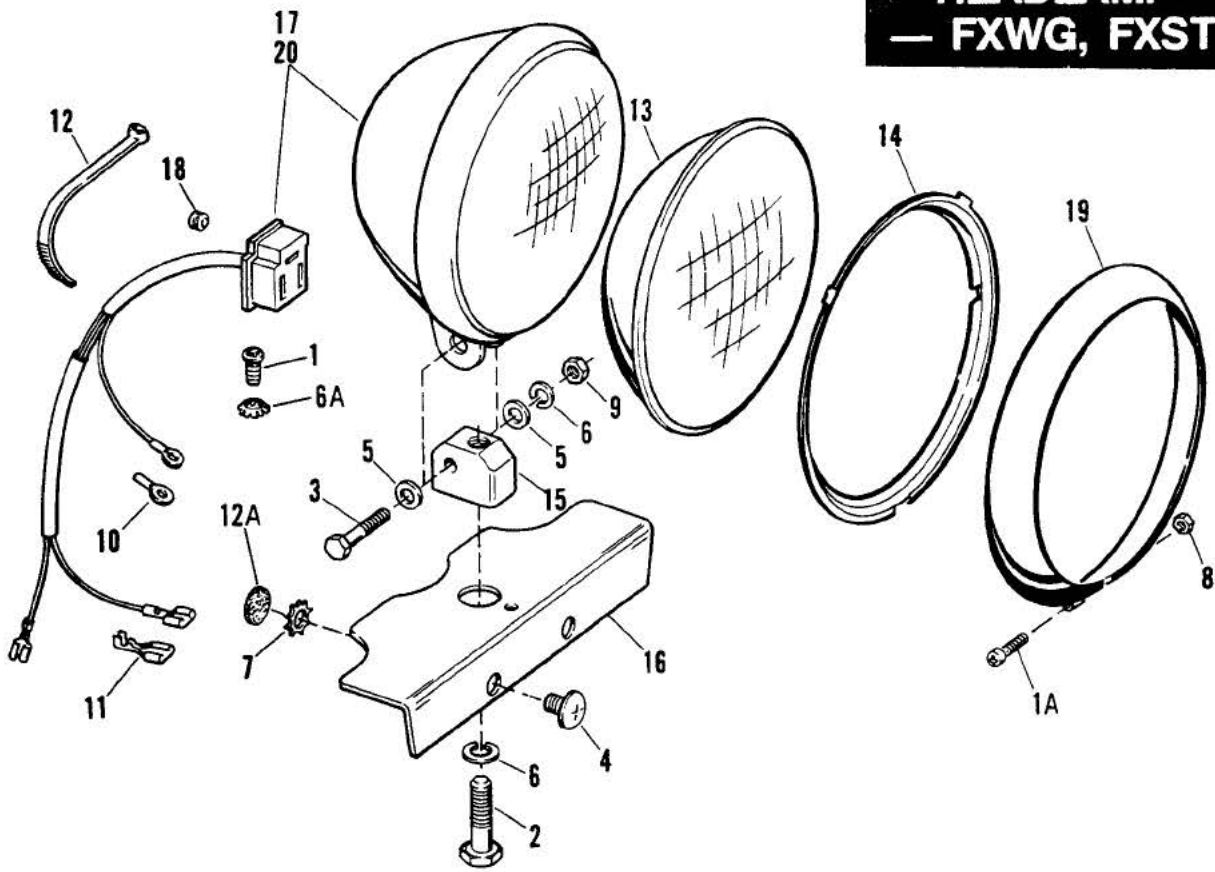

RETAIL PRICE	INDEX NO.	PART NO.	NAME	USED ON
	1	2583	SCREW, headlamp, ground	86 to * — FXST
	1A	3514	SCREW	84 to * — FXST; 85 to * — FXWG
	2	3945	BOLT	Late 85 to * — FXWG, FXST
		4412	BOLT	84 — FXST; Early 85 — FXWG, FXST
	3	4724	BOLT	84 to * — FXST; Early 85 — FXWG; 86 to * — FXWG
	4	5410	SCREW (chrome) (2)	84 & Early 85 — FXST; Early 85 — FXWG
	5	6701	WASHER (2)	85 to * — FXWG, FXSB, FXEF; 86 to * — FXST
	6	7038	LOCKWASHER (2)	84 to * — FXST; 85 to * — FXWG
	6A	7220	WASHER, headlamp, ground	86 to * — FXST
	7	7232	LOCKWASHER (2)	84 & Early 85 — FXST; Early 85 — FXWG
	8	7606	NUT	84 to * — FXST; 85 to * — FXWG
	9	7800W	NUT	84 to * — FXST; 85 to * — FXWG
	10	9857	WIRE TERMINAL, headlamp harness, ring type	84 to * — FXST; 85 to * — FXWG
	11	9931	WIRE TERMINAL, headlamp harness, female spade type (2)	84 — FXST
	12	10006	CABLE STRAP, headlamp wiring harness (2)	84 — FXST
		10065	CABLE STRAP	85 to * — FXWG, FXST
	12A	45648—85	PAD (felt) (2)	Late 85 to * — FXWG, FXST
	13	67698—81A	HEADLAMP — 12 V. halogen	84 to * — FXST; 85 to * — FXWG
	14	67769—82	MOUNTING RING	84 to * — FXST; 85 to * — FXWG
	15	67772—80	MOUNTING BLOCK, headlamp (chrome)	84 to * — FXST; 85 to * — FXWG
	16	67773—80A	MOUNTING PLATE, headlamp (chrome)	Late 85 to * — FXWG, FXST
	17	67777—82	HEADLAMP, complete — with wiring	85 to * — FXWG
	18	67788—82	GROMMET, headlamp wiring	84 to * — FXST; 85 to * — FXWG
	19	67790—82	HEADLAMP TRIM RING (chrome)	84 to * — FXST; 85 to * — FXWG
	20	67823—84	HEADLAMP, complete — with wiring	84 — FXST
		67823—85A	HEADLAMP, complete — with wiring	85 to * — FXST

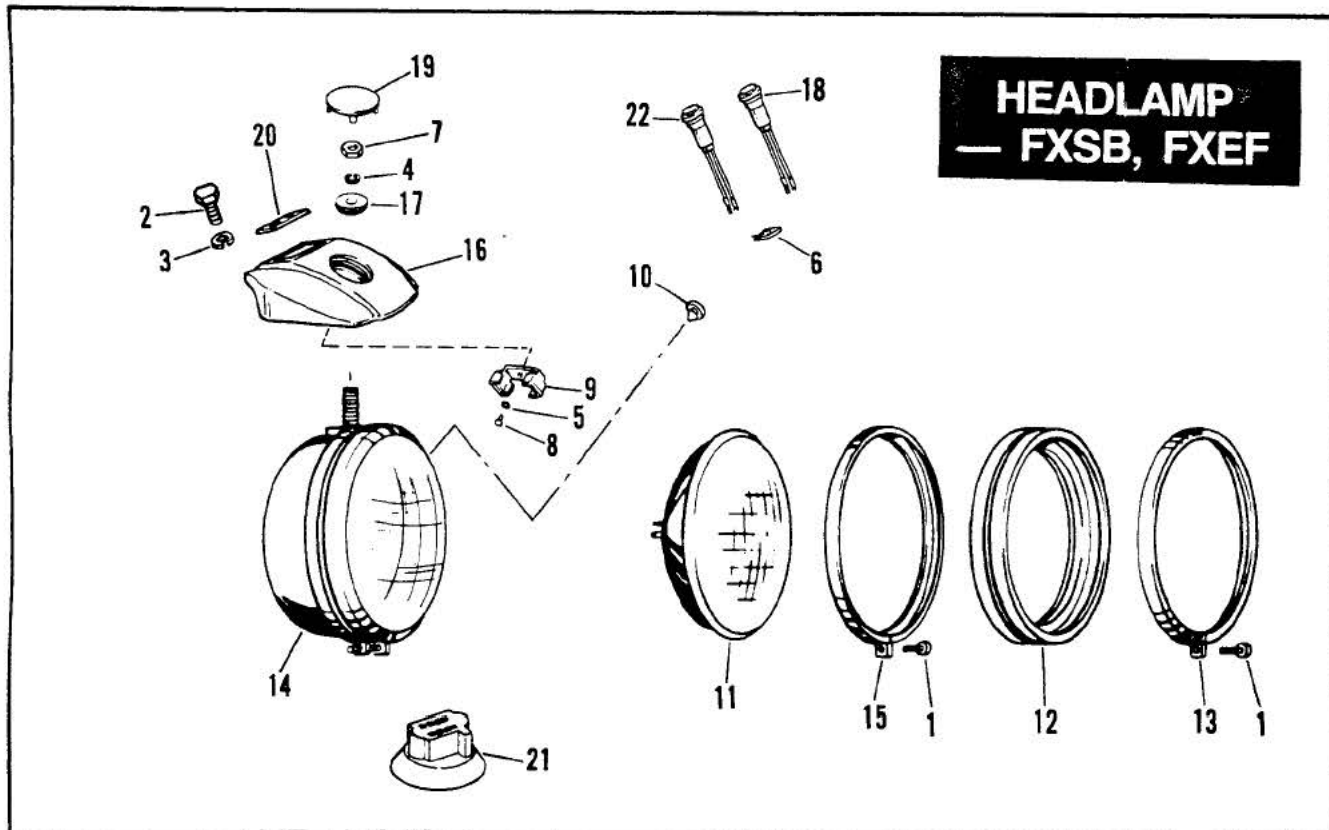

**HEADLAMP  
— FXSB, FXEF**

**HEADLAMP — FXSB, FXEF**

**FX41A**

RETAIL PRICE	INDEX NO.	PART NO.	NAME	USED ON
	1	1203	SCREW (2)	85 — FXSB, FXEF
	2	2871W	BOLT (2)	85 — FXSB, FXEF
	3	7041	LOCKWASHER (2)	85 — FXSB, FXEF
	4	7068	LOCKWASHER	85 — FXSB, FXEF
	5	7220	LOCKWASHER	85 — FXSB, FXEF
	6	7614	SPEED NUT (2)	85 — FXSB, FXEF
	7	7880	NUT	85 — FXSB, FXEF
	8	8519	RIVET, flasher clip	85 — FXSB, FXEF
	9	9952	FLASHER CLIP	85 — FXSB, FXEF
	10	11448	PLUG, headlamp housing	85 — FXSB, FXEF
	11	67698—81A	HEADLAMP — 12 V. halogen	85 — FXSB, FXEF
	12	67719—63	MOUNTING RING, resilient	85 — FXSB, FXEF
	13	67725—63	MOLDING RING, outer (2)	85 — FXSB, FXEF
	14	67743—84	HEADLAMP HOUSING	85 — FXSB, FXEF
	15	67744—75	MOLDING RING, inner	85 — FXSB, FXEF
	16	67809—75	BRACKET, headlamp	85 — FXSB, FXEF
	17	67815—59A	WASHER, headlamp mount	85 — FXSB, FXEF
	18	67851—75	INDICATOR LAMP, neutral (green)	85 — FXSB, FXEF
	19	67830—59	PLUG, headlamp bracket	85 — FXSB, FXEF
	20	67833—75	TRIM, headlamp bracket	85 — FXSB, FXEF
	21	67839—74	BOOT, headlamp connector	85 — FXSB, FXEF
	22	68536—75	INDICATOR LAMP, oil pressure (red)	85 — FXSB, FXEF

# TAIL LAMP

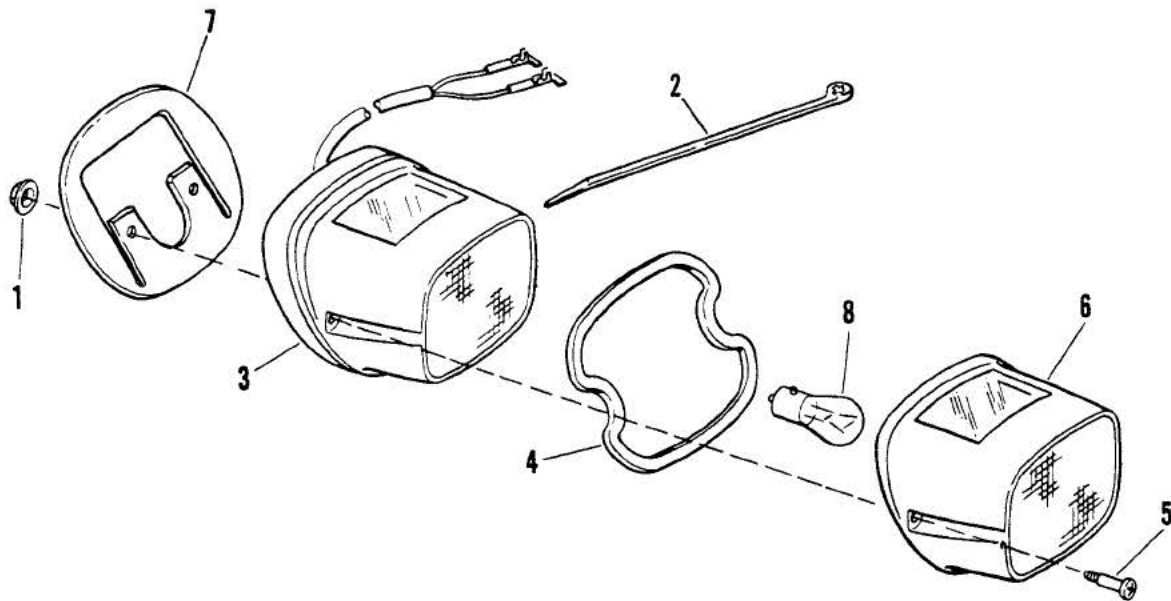

## TAIL LAMP

FX42

RETAIL PRICE	INDEX NO.	PART NO.	NAME	USED ON
	1	7501	SPEED NUT, 1/4 × 7/16 hex. (2)	84 — FXST; 85 to * — All Models
	2	10006	CABLE STRAP	84 — FXST; Early 85 — FXWG, FXST
		10065	CABLE STRAP	Late 85 to * — FXWG, FXST
	3	68007—77A	TAIL LAMP ASSEMBLY	84 to * — FXST; 85 to * — FXWG
		68008—73A	TAIL LAMP ASSEMBLY	85 — FXSB, FXEF
	4	68025—73	GASKET, tail lamp lens	84 — FXST; 85 to * — All Models
	5	68026—73	SCREW, tail lamp lens (2)	84 — FXST; 85 to * — All Models
	6	68034—77	LENS, tail lamp	84 — FXST; 85 to * — All Models
	7	68123—73	GASKET, tail lamp housing	85 — FXSB, FXEF
	8	68168—89	BULB, tail lamp — 12 V	84 — FXST; 85 to * — All Models

# TURN SIGNALS

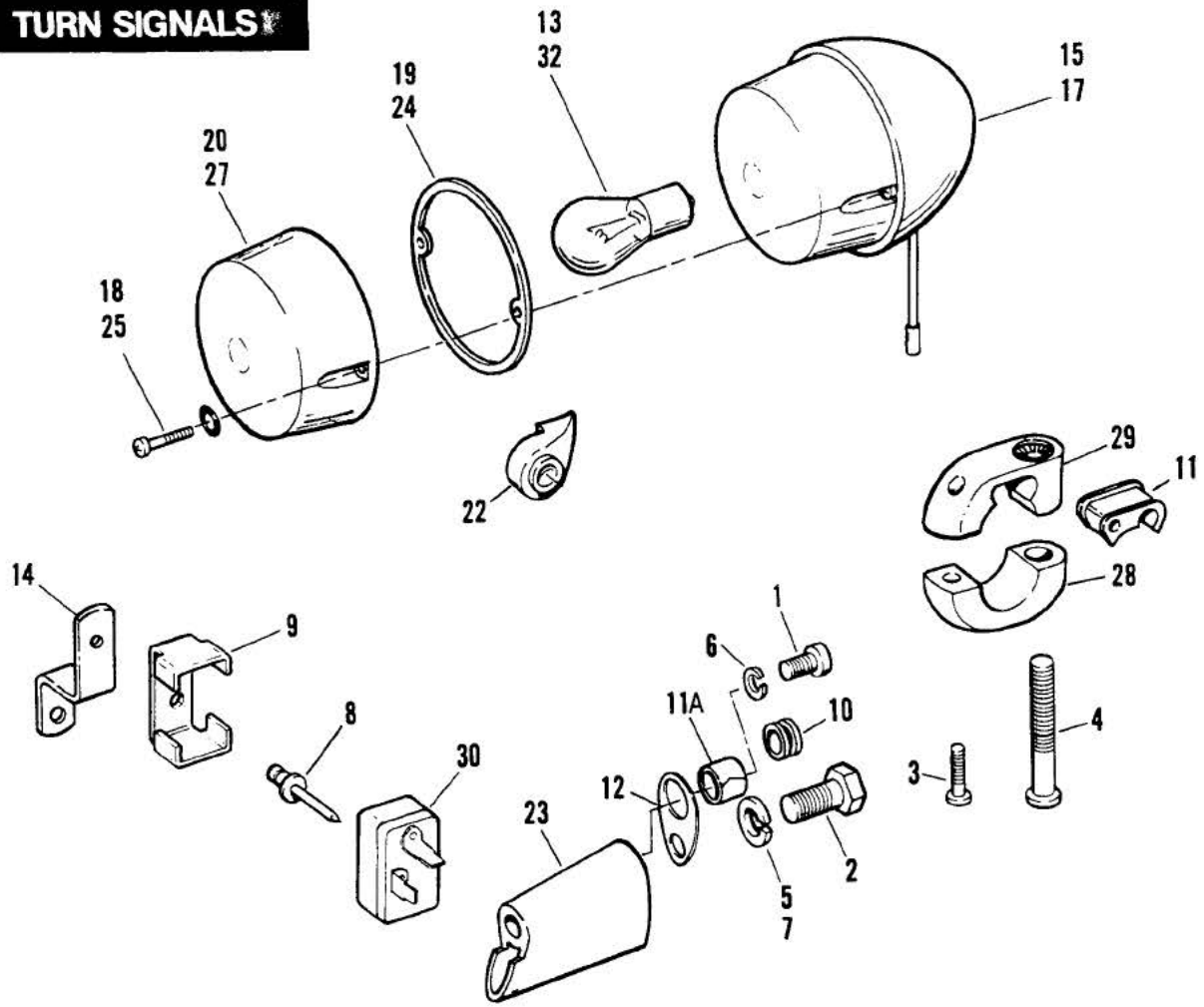

RETAIL PRICE	INDEX NO.	PART NO.	NAME	USED ON
	1	2698	SCREW (2) .....	84 — FXST; 85 to * — All Models
	2	2889	BOLT (2) .....	84 & 85 — FXST; 85 to * — FXWG, FXSB, FXEF
		2904	BOLT (2) .....	86 to * — FXST
	3	4069	BOLT (2) .....	84 — FXST; 85 to * — All Models
	4	4070	BOLT (2) .....	84 — FXST; 85 to * — All Models
	5	7038	LOCKWASHER (2) .....	84 & 85 — FXST; 85 to * — FXWG, FXSB, FXEF
	6	7042	LOCKWASHER (2) .....	84 — FXST; 85 to * — All Models
	7	7045	LOCKWASHER (2) .....	86 to * — FXST
	8	8490	POP RIVET .....	85 to * — FXWG
		8519	POP RIVET .....	85 — FXSB, FXEF
		8672	POP RIVET, flasher .....	84 to * — FXST
	9	9952	CLIP, flasher .....	84 — FXST; 85 to * — All Models
	10	11410	GROMMET, rear lamp wire (2) .....	Early 85 — FXWG, FXSB, FXEF
	11	11442	GROMMET, mounting clamp — left .....	84 & 85 — FXST; 85 — FXWG, FXSB, FXEF
		11449	GROMMET, mounting clamp (2) .....	84 to * — FXST; 85 to * — FXWG, FXSB, FXEF
		59710—84	COVER, rear turn signal hole (HDI part only) .....	86 to * — FXST
11A		59959—86	SPACER .....	86 to * — FXST
12		59968—85	GASKET (2) .....	85 to * — All Models
13		68168—89	BULB, turn signal — 12 V. — front (2) .....	86 to * — FXWG, FXST
14		68207—80	MOUNTING BRACKET .....	85 to * — FXWG
15		68406—86B	LAMP WITH WIRE — front (amber) (2) .....	86 to * — FXWG, FXST
		68407—86	LAMP WITH WIRE — rear (amber) (2) .....	86 to * — FXWG, FXST
17		68435—84	LAMP WITH WIRE (amber) (4) .....	84 — FXST; 85 — All Models
18		68452—86	SCREW w/O-RING, turn signal lens (8) .....	86 to * — FXWG, FXST
19		68455—86	GASKET, turn signal lens (4) .....	86 to * — FXWG, FXST
20		68457—86	LENS, turn signal (4) .....	86 to * — FXWG, FXST
22		68477—73	BRACKET, lamp (2) .....	84 — FXST; 85 to * — All Models
23		68480—73	SUPPORT, rear lamp mounting (2) .....	84 — FXST; 85 to * — All Models
24		68481—73	GASKET, turn signal lens (4) .....	84 — FXST; 85 — All Models
25		68482—73	SCREW, turn signal lens (8) .....	84 — FXST; 85 — All Models
27		68483—73	LENS, turn signal (4) .....	84 — FXST; 85 — All Models
28		68486—82A	CLAMP, handlebar (2) .....	84 — FXST; 85 to * — All Models
29		68487—82	CLAMP, handlebar (2) .....	84 — FXST; 85 to * — All Models
		68531—78	SUPPORT BRACKET, rear turn signal (chrome) (HDI part only) .....	86 to * — FXST
30		68543—64B	FLASHER .....	84 — FXST; 85 to * — All Models
		68550—83	FLASHER, turn signal (HDI part only) .....	86 to * — FXST
32		68572—64B	BULB, turn signal — 12 V. (4; 2 — rear — 86) .....	84 — FXST; 85 to * — All Models
		68578—84A	SUPPORT BRACKET, rear turn signal (threaded) (HDI part only) .....	86 to * — FXST

# HORN AND MIRROR

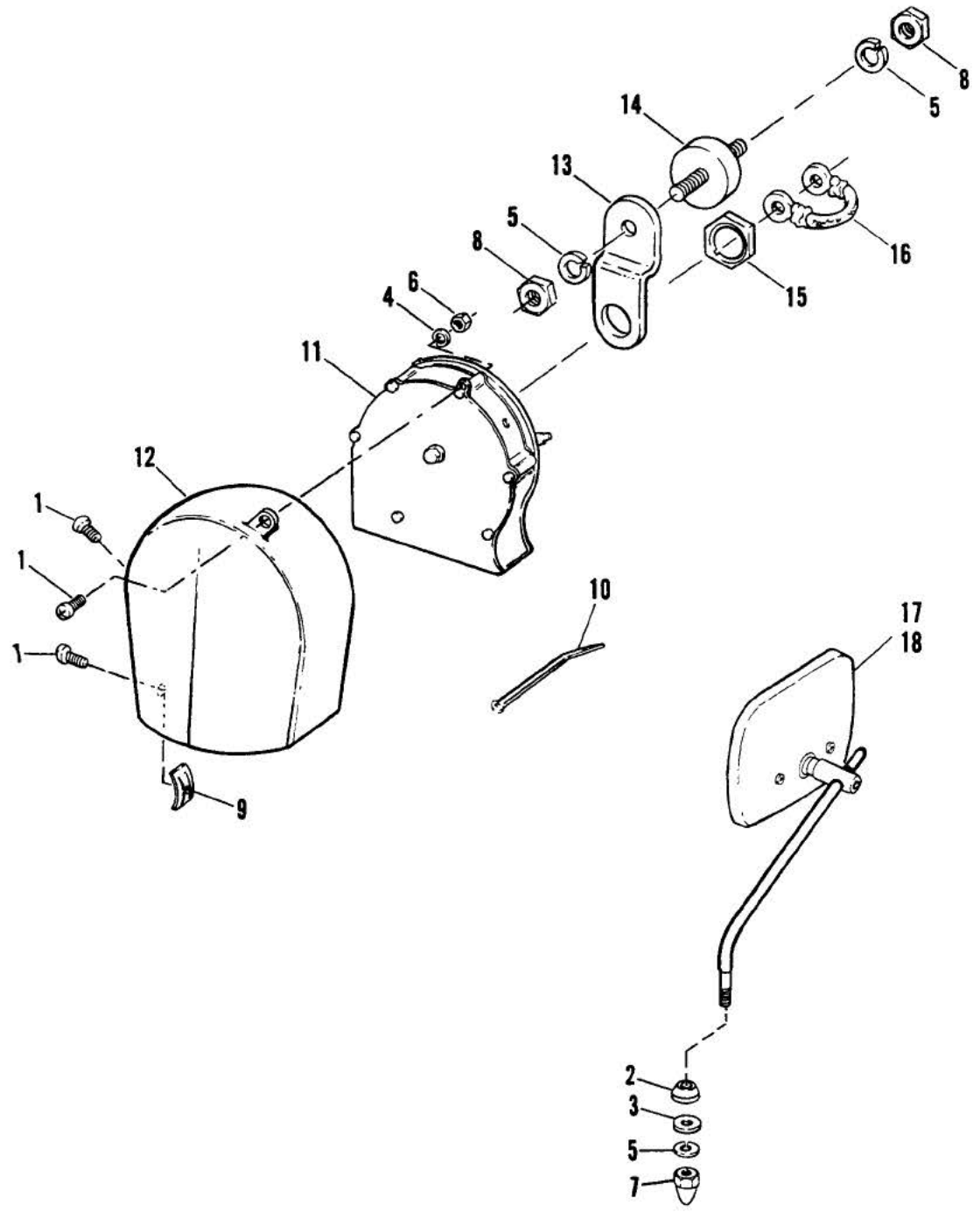

# HORN AND MIRROR

FX44

RETAIL PRICE	INDEX NO.	PART NO.	N A M E	USED ON
	1	1719W	SCREW (3) .....	84 — FXST; 85 to * — All Models
	2	5714	SPACER (2) .....	84 — FXST; 85 to * — All Models
	3	6702	WASHER (2) .....	84 — FXST; 85 to * — All Models
	4	7015	LOCKWASHER .....	84 — FXST; 85 to * — All Models
	5	7041	LOCKWASHER (4) .....	84 — FXST; 85 to * — All Models
	6	7608	NUT .....	84 — FXST; 85 to * — All Models
	7	7736	ACORN NUT (chrome) .....	84 — FXST; 85 to * — All Models
	8	7748W	NUT (2) .....	84 — FXST; 85 to * — All Models
	9	8125	SPEED NUT, horn cover .....	84 — FXST; 85 to * — All Models
	10	10006	PLASTIC STRAP, horn wire to frame .....	84 — FXST; 85 to * — All Models
	11	69016—76	HORN, high note .....	84 — FXST; 85 to * — All Models
	12	69017—76	COVER, high note horn .....	84 — FXST; 85 to * — All Models
	13	69118—84	MOUNTING BRACKET, horn .....	84 — FXST; 85 to * — All Models
	14	69125—65	RUBBER MOUNT, horn .....	84 — FXST; 85 to * — All Models
	15	69149—65	NUT, horn mounting .....	84 — FXST; 85 to * — All Models
	16	70016—65A	GROUND STRAP, horn .....	84 — FXST; 85 to * — All Models
	17	91875—82	MIRROR KIT, rectangular — right (chrome) .....	84 — FXST; 85 to * — All Models
	18	91892—82	MIRROR KIT, rectangular — left (chrome) .....	84 — FXST; 85 to * — All Models



# WIRING

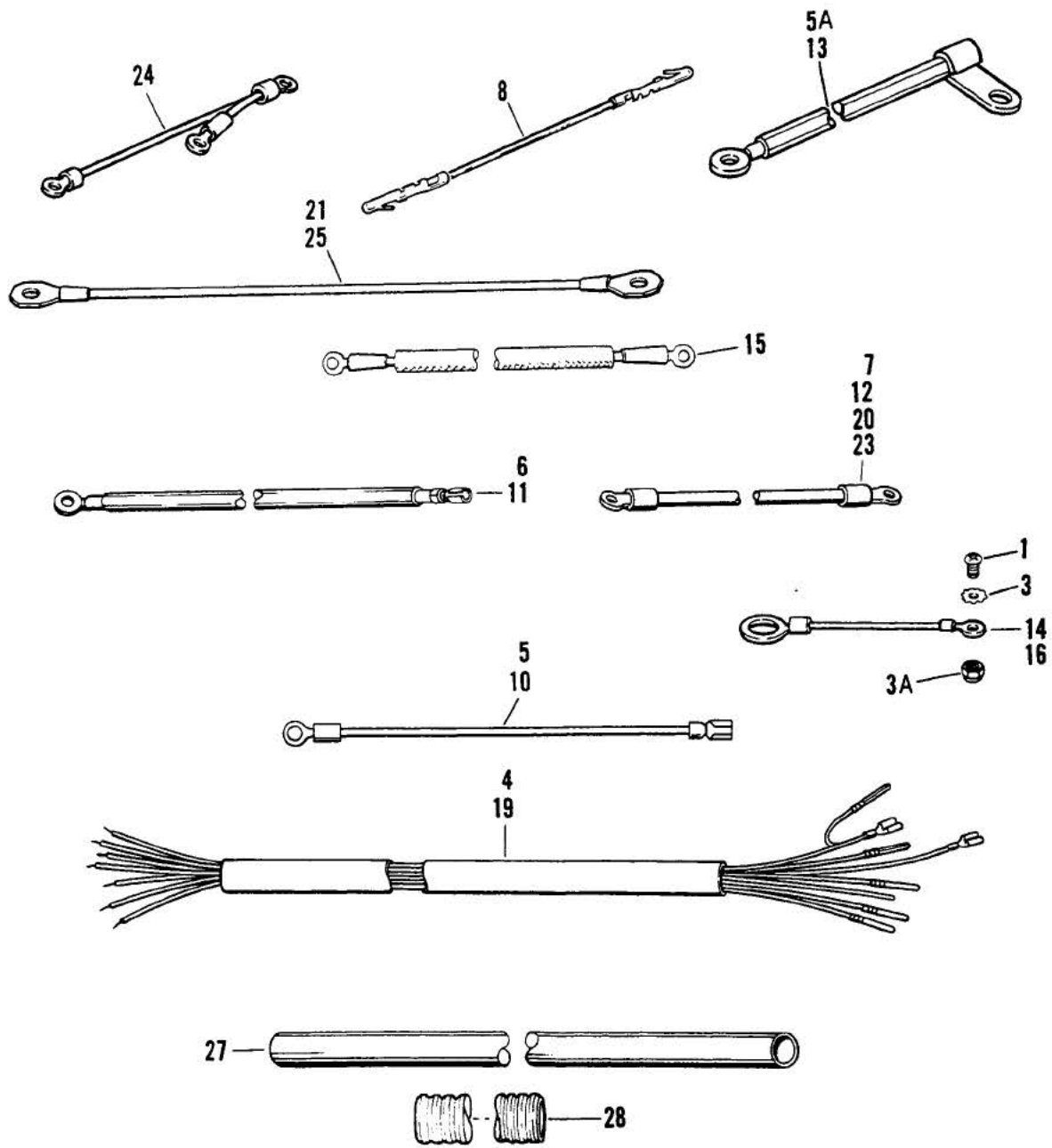

RETAIL PRICE	INDEX NO.	PART NO.	NAME	USED ON
	1	2583	SCREW, headlamp ground	85 to * — All Models
		2662W	SCREW, handlebar ground wire	85 to * — All Models
	3	7220	LOCKWASHER, ground wire (2)	85 to * — All Models
	3A	7624	LOCKNUT, relay ground wire	Late 85 to * — All Models
	4	69543—85	MAIN WIRING HARNESS	85 — FXSB, FXEF
	5	70000—84	WIRE ASSEMBLY, instrument ground (black) . . . . . N/A	Early 85 — FXSB, FXEF
	5A	70008—86	WIRE ASSEMBLY, starter ground wire	86 to * — FXST
	6	70009—85	CABLE ASSEMBLY, relay to starter switch . . . . . N/A	85 — FXWG, FXSB, FXEF
	7	70011—84A	WIRE ASSEMBLY, battery ground	84 to * — FXST
	8	70022—83	WIRE ASSEMBLY, to left front directional	85 to * — FXSB, FXEF
		70027—83	WIRE ASSEMBLY, to right front directional	85 to * — FXSB, FXEF
		70049—83	WIRE ASSEMBLY, direction to flasher (orange)	85 to * — FXSB, FXEF
	10	70050—83	WIRE ASSEMBLY, headlamp ground	85 to * — FXSB, FXEF
	11	70064—84A	CABLE, battery to solenoid	84 to * — FXST
	12	70069—65B	CABLE, solenoid to starter	85 — All Models
		70069—83A	CABLE, solenoid to starter	86 to * — FXWG
	13	70081—85	CABLE, battery (positive)	85 to * — FXST
	14	70085—80	WIRE, handlebar ground (black)	84 to * — FXST; 85 to * — FXWG
	15	70107—80	WIRE, flasher (orange) . . . . . N/A	84 to * — FXST; 85 to * — FXWG
	16	70146—84	CABLE ASSEMBLY, starter solenoid	85 to * — All Models
		70155—84	CABLE, relay ground . . . . . N/A	85 to * — FXST
		70191—73A	WIRE, handlebar ground	85 to * — FXSB, FXEF
		70205—84	CABLE ASSEMBLY, relay to main circuit breaker	85 to * — FXST
	19	70207—84	MAIN WIRING HARNESS	85 to * — FXST
		70214—85	MAIN WIRING HARNESS	85 to * — FXWG
		70216—84	MAIN WIRING HARNESS	84 — FXST
		70216—85	MAIN WIRING HARNESS	Late 85 to * — FXST
		70226—85	MAIN WIRING HARNESS	86 to * — FXWG
	20	70244—85	CABLE ASSEMBLY, relay to solenoid	85 to * — FXWG, FXSB, FXEF
		70246—85	CABLE ASSEMBLY, relay to battery (positive)	85 to * — FXWG, FXSB, FXEF
	22	70256—84	WIRE ASSEMBLY, to indicator & gauges (orange) . . N/A	85 to * — FXSB, FXEF
	23	70258—84	WIRE ASSEMBLY, rear stud — ignition circuit breaker (white) . . . . . N/A	85 — FXSB, FXEF
	24	70259—84	WIRE ASSEMBLY, rear stud — light circuit breaker (green with white stripe) . . . . . N/A	85 — FXSB, FXEF
	25	70262—79	CABLE, circuit breaker to solenoid	84, 86 to * — FXST
		70461—67B	CABLE, battery ground	85 — FXSB, FXEF; 85 & 86 — FXWG
	27	70551—69	CONDUIT, 1/8 I.D. x 10 ft. lg. (black vinyl) (hi temp) . .	85 to * — All Models
		70552—69	CONDUIT, 3/8 I.D. x 10 ft. lg. (black vinyl)	85 to * — All Models
		70553—69	CONDUIT, 7/16 I.D. x 10 ft. lg. (black vinyl)	85 to * — All Models
		70554—69	CONDUIT, 1/4 I.D. x 10 ft. lg. (black vinyl)	85 to * — All Models
		70555—69	CONDUIT, 1/4 I.D. x 10 ft. lg. (black vinyl) (hi temp) . .	85 to * — All Models
		70556—71	CONDUIT, 5/16 I.D. x 10 ft. lg. (black vinyl)	85 to * — All Models
		70558—71	CONDUIT, 1/2 I.D. x 10 ft. lg. (black vinyl)	85 to * — All Models
		70559—71	CONDUIT, 1/8 I.D. x 10 ft. lg. (black vinyl)	85 to * — All Models
		91704—15	BRAIDED CABLE, 16 strand (soft black)	85 to * — All Models
	28	63505—84	INSULATOR, 1/2 I.D., battery positive cable (nylon)(8 ft. lg.)	85 to * — FXST

NOTE: Insulator is sold only in bulk length under the following part number. Cut to required length.

# MISCELLANEOUS ELECTRICAL

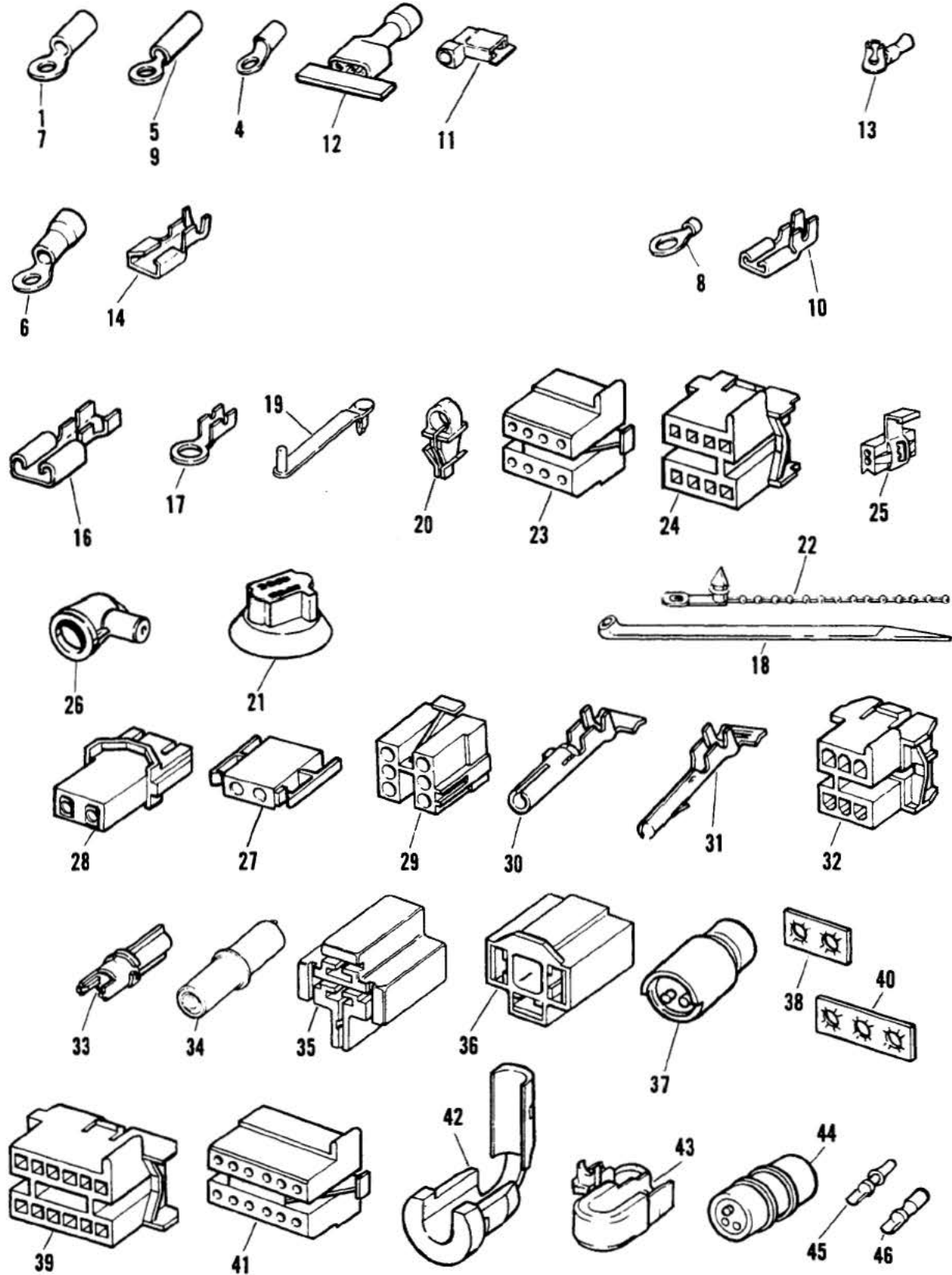

RETAIL PRICE	INDEX NO.	PART NO.	NAME	USED ON
	1	9856	WIRE TERMINAL, ring type, No. 6 hole #16-22 wire . . .	84 to * — FXST; 85 to * — FXWG
		9857	WIRE TERMINAL, ring type, No. 10 hole, #16-22 wire . . .	84 — FXST; 85 to * — All Models
		9858	WIRE TERMINAL, ring type, 1/4 dia. hole, #16-22 wire . . .	85 — FXSB, FXEF
	4	9860	WIRE TERMINAL, female spade type, 3/8 slot, #16-22 wire . . .	85 to * — All Models
	5	9862	WIRE TERMINAL, ring type, 1/4 dia. hole, #14-16 wire . . .	84 — FXST; 85 to * — All Models
	6	9863	WIRE TERMINAL, ring type, 1/4 dia. hole, #14-16 wire . . .	85 to * — FXWG, FXST
	7	9864	WIRE TERMINAL, ring type, 5/16 dia. hole, #16-22 wire . . .	85 to * — FXWG, FXST
	8	9866	WIRE TERMINAL, ring type, No. 10 hole, #10-12 wire . . .	84 — FXST; 86 to * — FXWG, FXST
	9	9871	WIRE TERMINAL, ring type, No. 6 hole, #14-16 wire . . .	84 to * — FXWG, FXST
	10	9875	WIRE TERMINAL, female spade, 5/16 slot, #16-22 wire . . .	84 — FXST; 85 to * — All Models
	11	9898	WIRE TERMINAL, female flag — insulated . . . . .	84 — FXST; 85 to * — All Models
	12	9900	CONNECTOR, wire (2) . . . . .	84 — FXST; 86 to * — All Models
	13	9905	WIRE TERMINAL, 1/4 dia. cap type — #18-22 wire . . .	85 to * — FXWG, FXSB, FXEF; 86 to * — FXST
	14	9914	WIRE TERMINAL, female spade type — 1/4 slot . . . . .	85 to * — FXWG, FXSB, FXEF
		9931	WIRE TERMINAL, female spade, 3/16 slot, #16-20 wire . . .	85 to * — FXWG, FXSB, FXEF
	16	9937	WIRE TERMINAL, female spade, 1/4 slot, #14-18 wire . . .	84 — FXST; 86 to * — FXWG, FXST
	17	9945	WIRE TERMINAL, ring type, 5/16 dia. hole, #10-12 wire . . .	85 to * — FXWG, FXSB, FXEF
	18	10006	CABLE STRAP (black) . . . . .	85 to * — All Models
		10007	CABLE STRAP (white) (2) . . . . .	85 to * — All Models
		10039	CABLE STRAP (2) . . . . .	85 to * — FXWG, FXST
		10065	CABLE STRAP . . . . .	85 to * — FXWG, FXST
		10073	CABLE STRAP (4) . . . . .	Late 85 to * — All Models
	19	10078	CABLE HANGER . . . . .	Early 85 — FXSB, FXEF
	20	56073—83	RETAINER, handlebar switch wiring (4) . . . . .	84 — FXST; 85 to * — All Models
	21	67839—74	BOOT, headlamp connector . . . . .	85 — FXSB, FXEF
	22	70005—70	CABLE STRAP (2) . . . . .	85 to * — FXWG, FXST
	23	70287—81	CONNECTOR, eight socket (2) . . . . .	84 to * — FXST; 85 to * — FXWG
	24	70288—81	CONNECTOR, eight socket . . . . .	84 to * — FXST; 85 to * — FXWG
	25	70576—68	WIRE CONNECTOR (6 — FXWG) . . . . .	84 — FXST; 85 to * — All Models
	26	70579—65	BOOT, insulating . . . . .	85 to * — All Models
	27	72034—71	CONNECTOR, double socket . . . . .	84 & 85 — FXST; 85 to * — FXWG, FXSB, FXEF
	28	72035—71	CONNECTOR, double pin (2) . . . . .	85 — FXSB, FXEF, 86 to * — FXWG, FXST
	29	72037—71	CONNECTOR, six socket (2 — FXEF) . . . . .	85 — FXSB, FXEF
	30	72038—71	SOCKET, single pin . . . . .	84 — FXST; 85 to * — All Models
	31	72039—71	PIN, single socket . . . . .	84 — FXST; 85 to * — All Models
	32	72041—71	CONNECTOR, six pin . . . . .	85 — FXSB, FXEF
	33	72043—71	CONNECTOR, single pin . . . . .	84 — FXST; 85 to * — All Models
	34	72044—71	CONNECTOR, single socket . . . . .	84 to * — FXST; 85 to * — FXWG
	35	72046—79	HOUSING, socket (starter relay) . . . . .	84 — FXST; 86 to * — FXWG, FXST
	36	72047—71	INSULATOR, spade terminal — headlamp wiring harness . . . . .	85 — FXSB, FXEF
	37	72051—77	CONNECTOR, three socket . . . . .	84 — FXST; 85 to * — All Models
	38	72275—74	CONNECTOR TAB, 2 terminal . . . . .	85 — FXSB, FXEF
	39	72276—74	HOUSING, pin (2) . . . . .	85 — FXSB, FXEF
	40	72277—74	CONNECTOR TAB, 3 terminal (2) . . . . .	85 — FXSB, FXEF
	41	72278—74	HOUSING, socket (2) . . . . .	85 — FXSB, FXEF
	42	72501—74	BUSHING, straight . . . . .	85 — FXSB, FXEF
	43	72502—74	BUSHING, right angle (2) . . . . .	85 — FXSB, FXEF
	44	74521—77	CONNECTOR, pin and socket . . . . .	84 — FXST; 85 to * — All Models
	45	74536—77A	SOCKET, single pin (3) . . . . .	84 — FXST; 85 to * — All Models
	46	74539—77A	PIN, single socket (3) . . . . .	84 — FXST; 85 to * — All Models

# HANDLEBAR SWITCHES

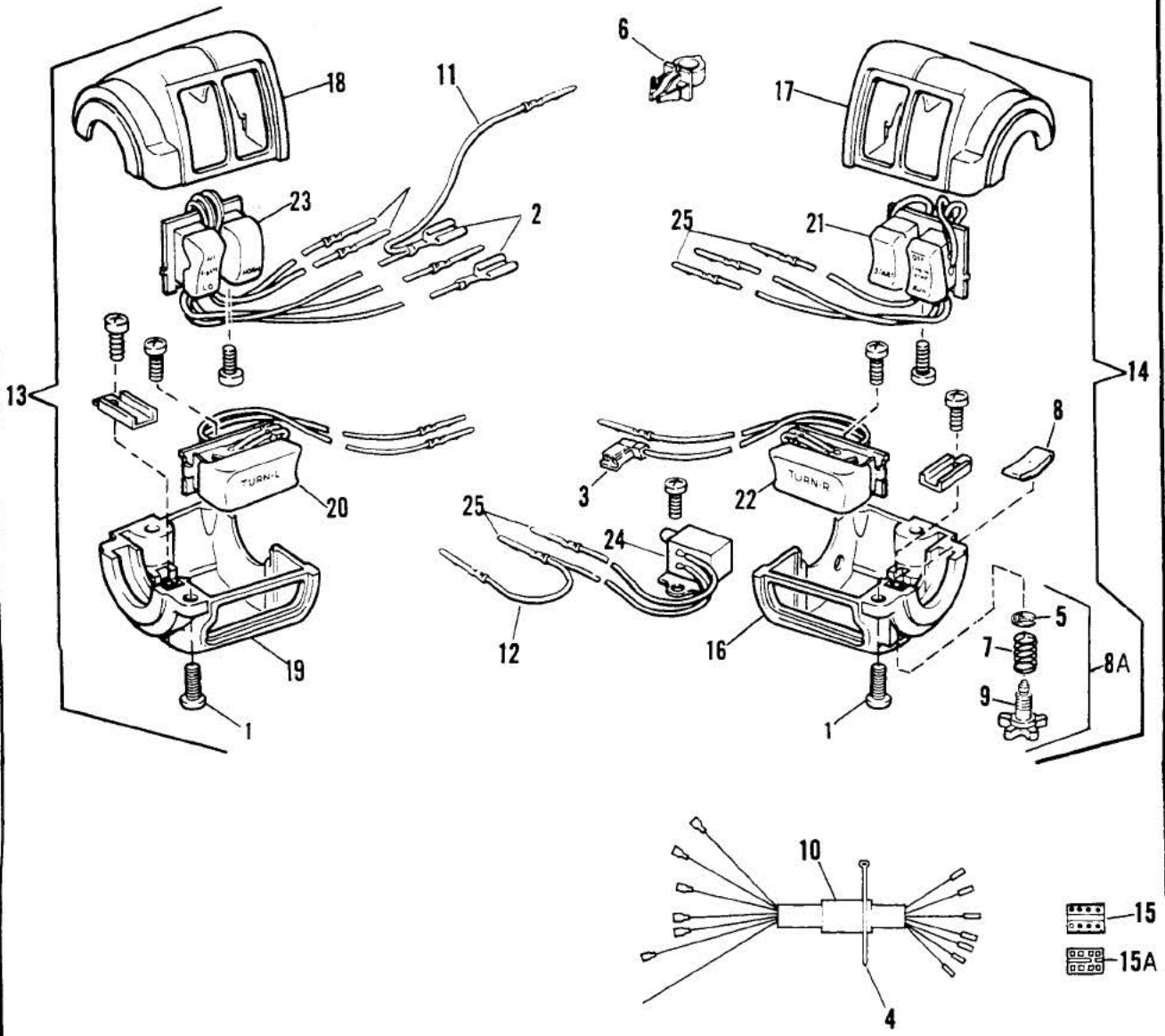

# HANDLEBAR SWITCHES

FX47

RETAIL PRICE	INDEX NO.	PART NO.	NAME	USED ON
	1	2508	SCREW (4)	84 — FXST; 85 to * — All Models
	2	9875	WIRE TERMINAL, female spade type (2)	84 — FXST; 85 to * — All Models
	3	9898	WIRE TERMINAL, female spade, insulated	84 — FXST; 85 to * — All Models
	4	10007	CABLE STRAP, wiring harness (2)	84 — FXST; Early 85 — All Models
		10065	CABLE STRAP (2)	Late 85 to * — All Models
	5	11155	RETAINING RING	84 to * — FXST; 85 to * — All Models
	6	56073—83	RETAINER, wiring harness (4)	84 — FXST; 85 to * — All Models
	7	56394—74	SPRING, adjusting screw	84 to * — FXST; 85 to * — All Models
	8	56396—74	SPRING, grip	84 to * — FXST; 85 to * — All Models
	8A	56397—74C	ADJUSTING SCREW KIT, includes items 5, 7 & 9	84 — FXST; 85 to * — All Models
	9	56402—83A	ADJUSTING SCREW, only	84 to * — FXST; 85 to * — All Models
	10	70037—82	WIRING HARNESS, left handlebar	85 to * — FXWG
		70038—82	WIRING HARNESS, right handlebar	85 to * — FXWG
		70092—84	WIRING HARNESS, left handlebar	84 to * — FXST
		70093—84	WIRING HARNESS, right handlebar	84 to * — FXST
	11	70047—82	WIRE ASSEMBLY, 5' lg. (white)	84 — FXST; 85 to * — All Models
	12	70082—82	WIRE ASSEMBLY, 3' lg. (orange)	84 — FXST; 85 to * — All Models
	13	70218—87	SWITCH ASSEMBLY, complete — left	84 — FXST; 85 — All Models
		70218—86A	SWITCH ASSEMBLY, complete — left	86 to * — FXWG, FXST
	14	70219—87	SWITCH ASSEMBLY, complete — right	84 — FXST; 85 — All Models
		70219—86A	SWITCH ASSEMBLY, complete — right	86 to * — FXWG, FXST
	15	70287—81	HOUSING, socket (2)	84 to * — FXST; 85 to * — FXWG
	15A	70288—81	HOUSING, pin	84 to * — FXST; 85 to * — FXWG
	16	71563—82A	HOUSING, lower, right	84 — FXST; 85 to * — FXWG, FXST
	17	71564—82A	HOUSING, upper, right	84 — FXST; 85 to * — All Models
	18	71567—82	HOUSING, upper, left	84 — FXST; 85 to * — All Models
	19	71568—82A	HOUSING, lower, left	84 — FXST; 85 — All Models; 86 to * — FXWG, FXST
	20	71570—82A	SWITCH ASSEMBLY, w/terminals, left directional	84 — FXST; 85 — All Models
		71570—86A	SWITCH ASSEMBLY, w/terminals, left directional	86 to * — FXWG, FXST
	21	71571—82	SWITCH ASSEMBLY, w/terminals, engine stop & start	84 — FXST; 85 to * — All Models
	22	71572—82A	SWITCH ASSEMBLY, w/terminals, right directional	84 — FXST; 85 — All Models
		71572—86A	SWITCH ASSEMBLY, w/terminals, right directional	86 to * — FXWG, FXST
	23	71573—82A	SWITCH ASSEMBLY, w/terminals & wiring, dimmer & horn	84 — FXST; 85 — All Models; 86 to * — FXWG, FXST
	24	71574—82	STOPLIGHT SWITCH, w/terminals & wiring	84 — FXST; 85 to * — All Models
	25	72039—71	PIN, single socket	84 — FXST; 85 to * — All Models

# SPEEDOMETER AND INSTRUMENT PANEL — FXWG, FXST

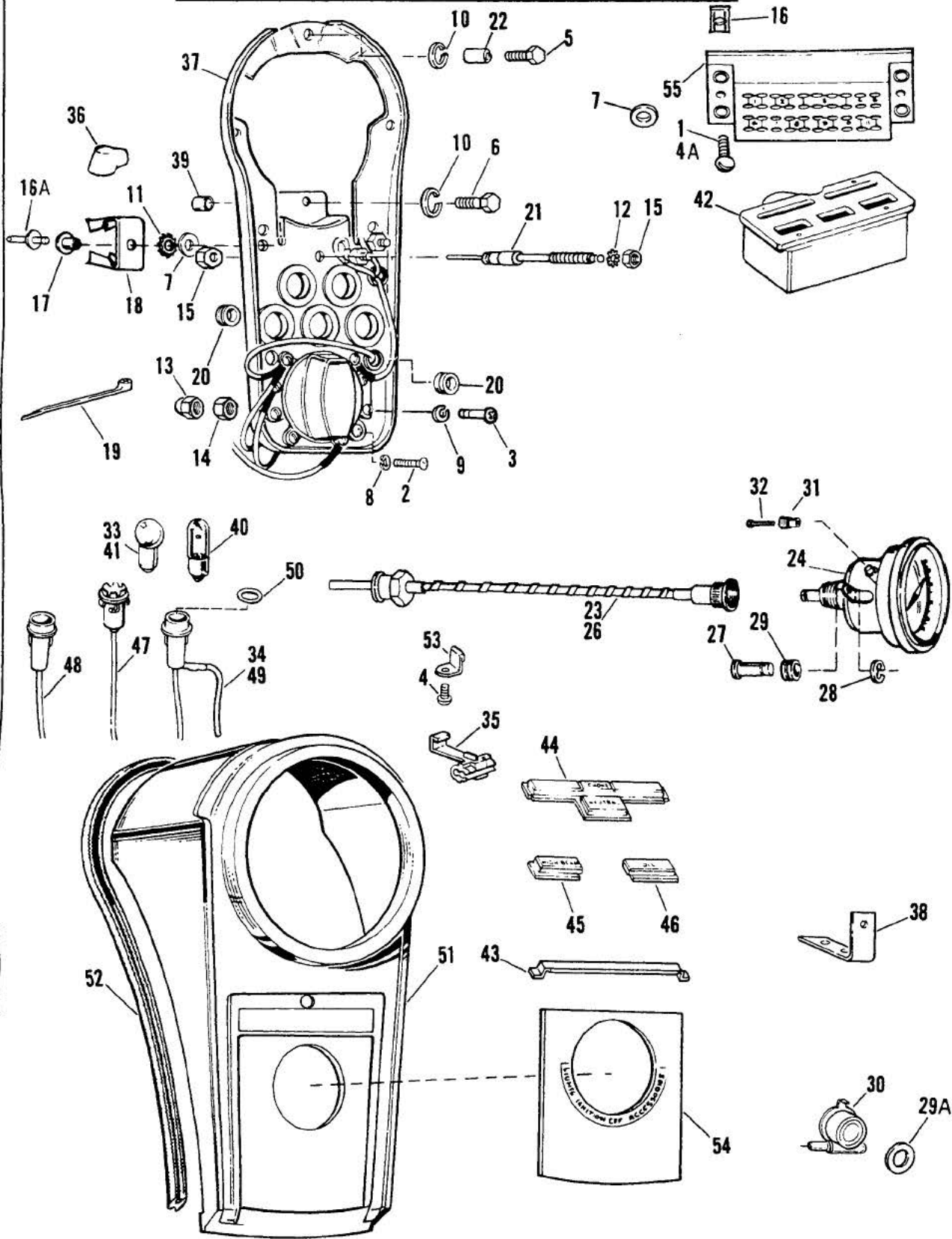

# SPEEDOMETER & INSTRUMENT PANEL — FXWG, FXST

FX48-1

RETAIL PRICE	INDEX NO.	PART NO.	NAME	USED ON
	1	1203	SCREW (2)	84 to * — FXST
	2	2574W	SCREW (6)	84 to * — FXST; 85 to * — FXWG
	3	2594	SCREW (4)	84 to * — FXST; 85 to * — FXWG
	4	2630W	SCREW (2)	84 to * — FXST; 85 to * — FXWG
	4A	2779	SCREW (4)	85 to * — FXWG
	5	3419	BOLT	84 to * — FXST; 85 to * — FXWG
	6	4068	BOLT (2)	84 to * — FXST; 85 to * — FXWG
	7	6192	WASHER (2)	84 to * — FXST; 85 to * — FXWG
	8	7010	LOCKWASHER (6)	84 to * — FXST; 85 to * — FXWG
	9	7015	LOCKWASHER (4)	84 to * — FXST; 85 to * — FXWG
	10	7041	LOCKWASHER (3)	84 to * — FXST; 85 to * — FXWG
	11	7229W	LOCKWASHER (3)	84 to * — FXST; 85 to * — FXWG
	12	7232	LOCKWASHER (3 — 84 & 85)	84 to * — FXST; 85 to * — FXWG
	13	7602	ACORN NUT (locking) (5)	84 to * — FXST; 85 to * — FXWG
	14	7638	NUT (6)	84 to * — FXST; 85 to * — FXWG
	15	7744	NUT (2)	84 to * — FXST; 85 to * — FXWG
	16	8155	SPEED NUT (2)	84 to * — FXST
	16A	8483	POP RIVET, bracket mounting	84 to * — FXST; 86 — FXWG
	17	8519	RIVET, flasher clip (2)	84 & 85 — FXST; 85 — FXWG
		8672	POP RIVET, flasher clip (3)	86 to * — FXWG, FXST
	18	9952	FLASHER CLIP (3)	84 to * — FXST; 85 to * — FXWG
	19	10065	STRAP, main wiring harness (5; 6 — 86 & Later)	84 to * — FXST; 85 to * — FXWG
	20	11430	GROMMET, instrument panel (2)	84 to * — FXST; 85 to * — FXWG
	21	29211—86	CONTROL CABLE, choke	86 to * — FXWG; FXST
		29213—79	CONTROL CABLE, choke	84 & 85 — FXST; 85 — FXWG
	22	62043—81A	SPACER, panel mounting	84 to * — FXST; 85 & 86 — FXWG
	23	67024—84A	CABLE CORE & CASING, speedometer	85 to * — FXWG, FXST
	24	67027—81C	SPEEDOMETER HEAD, 120 m.p.h.	84 — FXST; 85 to * — FXWG, FXST
		67030—81D	SPEEDOMETER HEAD, k.p.h.	84 — FXST; 85 to * — FXWG, FXST
	26	67038—84	CABLE CORE AND CASING, speedometer	84 — FXST
	27	67068—76	PIN, speedometer mounting (2)	84 to * — FXST; 85 to * — FXWG
	28	67069—76	RETAINING RING, speedometer mounting (2)	84 to * — FXST; 85 to * — FXWG
	29	67070—76	GROMMET, speedometer mounting (2)	84 to * — FXST; 85 to * — FXWG
	29A	67118—87	SEAL, drive unit	84 to * — FXST; 85 to * — FXWG
	30	67120—84B	DRIVE UNIT ASSEMBLY, speedometer	84 — FXST; 85 to * — FXWG, FXST
	31	67215—68	KNOB, odometer reset	84 to * — FXST; 85 to * — FXWG
	32	67217—68	SCREW, reset knob	84 to * — FXST; 85 to * — FXWG
	33	68462—64	BULB, signal lamps — 12 V. (4)	84 to * — FXST; 85 to * — FXWG
	34	68582—73	SOCKET, neutral indicator	84 to * — FXST; 85 to * — FXWG
	35	70576—68	WIRE CONNECTOR	84 to * — FXST; 85 to * — FXWG
	36	70579—65	INSULATING BOOT, main wiring harness	84 to * — FXST; 85 to * — FXWG
	37	70936—84	INSTRUMENT PANEL BASE	84 to * — FXST; 85 to * — FXWG
	38	70939—84A	BRACKET, circuit breaker	84 to * — FXST; 85 to * — FXWG



# SPEEDOMETER AND INSTRUMENT PANEL — FXWG, FXST

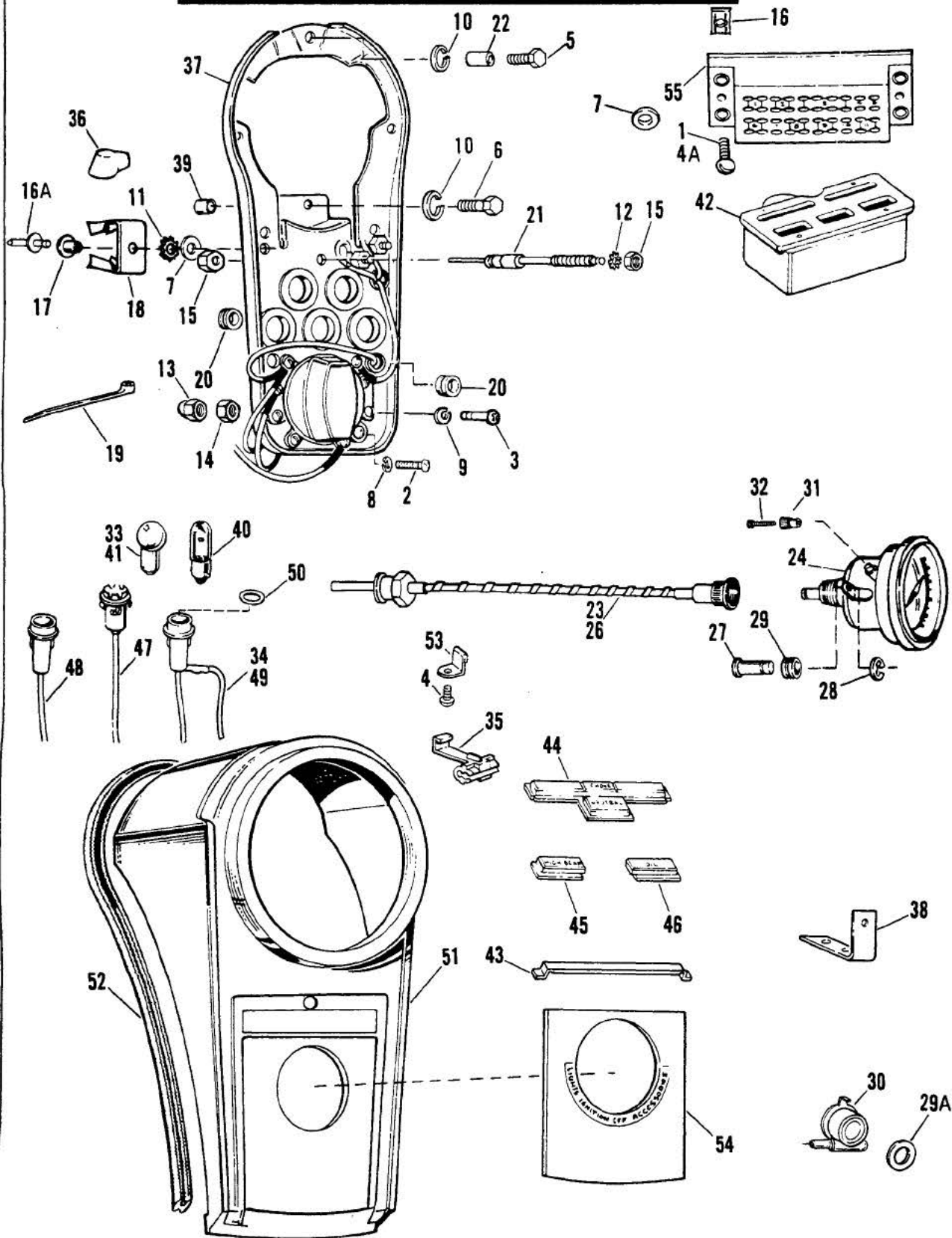

RETAIL PRICE	INDEX NO.	PART NO.	NAME	USED ON
	39	70941—84A	SPACER, instrument panel mounting (2) . . . . .	84 — FXST; 85 to * — FXWG, FXST
	40	71090—64	BULB, speedometer lamp — 12 V. . . . .	84 to * — FXST; 85 to * — FXWG
	41	71092—68A	BULB, high beam . . . . .	84 to * — FXST; 85 to * — FXWG
	42	71134—68	SUPPORT, indicator lamp lens . . . . .	84 to * — FXST; 85 to * — FXWG
	43	71141—68	RETAINER, indicator lamp lens . . . . .	84 to * — FXST; 85 to * — FXWG
	44	71143—75	LENS, directional lamp (green) . . . . .	84 to * — FXST; 85 to * — FXWG
	45	71144—75A	LENS, high beam (blue) . . . . .	84 to * — FXST; 85 to * — FXWG
	46	71145—75	LENS, oil indicator (red) . . . . .	84 to * — FXST; 85 to * — FXWG
	47	71159—73A	SOCKET, speedometer lamp (2) . . . . .	84 — FXST; 85 to Early 86 — FXWG, FXST
		71158—86	SOCKET, speedometer lamp . . . . .	Late 86 to * — FXST
	48	71162—70	SOCKET (2) . . . . .	84 to * — FXST; 85 to * — FXWG
	49	71166—73	SOCKET, oil signal lamp . . . . .	84 to * — FXST; 85 to * — FXWG
	50	71182—47A	WASHER, signal lamp socket . . . . .	84 to * — FXST; 85 to * — FXWG
	51	71240—80	COVER, instrument panel (black wrinkle) . . . . .	N/A
	52	71295—68	GASKET, instrument panel cover . . . . .	84 to * — FXST; ;85 to * — FXWG
	53	71297—68	CLIP, lens support (2) . . . . .	84 to * — FXST; 85 to * — FXWG
	54	71300—68A	PLATE, ignition switch (black) . . . . .	84 — FXST
		71300—79	PLATE, ignition switch (chrome) . . . . .	85 to * — FXWG, FXST
	55	72312—73	TERMINAL BLOCK . . . . .	84 to * — FXST; 85 to * — FXWG

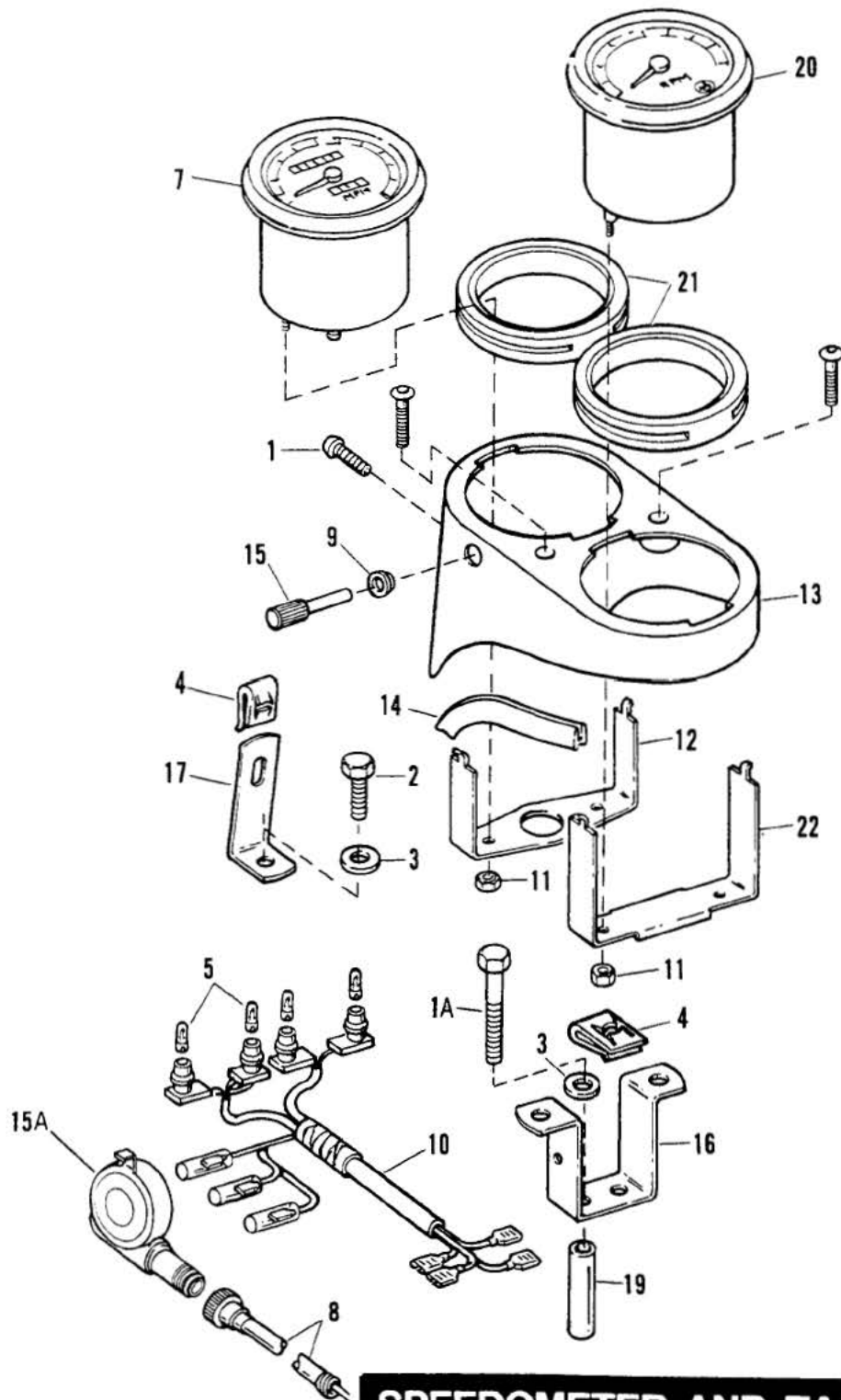

**SPEEDOMETER AND TACHOMETER  
— FXSB, FXEF**

RETAIL PRICE	INDEX NO.	PART NO.	NAME	USED ON
	1	923	SCREW .....	85 — FXSB, FXEF
	1A	4068	BOLT (2) .....	85 — FXSB, FXEF
	2	4092	BOLT .....	85 — FXSB, FXEF
	3	7041	WASHER (3) .....	85 — FXSB, FXEF
	4	8108	SPEED NUT (3) .....	85 — FXSB, FXEF
	5	53439—79	BULB (4) .....	85 — FXSB, FXEF
	7	67020—85	SPEEDOMETER, m.p.h. ....	85 — FXSB, FXEF
		67021—85A	SPEEDOMETER, k.p.h. ....	85 — FXSB, FXEF
	8	67077—85	CABLE CORE AND CASING .....	85 — FXEF
		67078—85A	CABLE CORE AND CASING .....	85 — FXSB
	9	67086—85	GROMMET .....	85 — FXSB, FXEF
	10	67091—85	WIRE ASSEMBLY, housing to headlamp, includes bulbs .....	N/A 85 — FXSB, FXEF
	11	67094—85	NUT (4) .....	85 — FXSB, FXEF
	12	67095—85	BRACKET, speedometer .....	85 — FXSB, FXEF
	13	67116—85	HOUSING, speedometer & tachometer .....	85 — FXSB, FXEF
	14	67119—85	GASKET, housing .....	85 — FXSB, FXEF
	15	67122—85	KNOB, odometer reset .....	85 — FXSB, FXEF
	15A	67127—84A	DRIVE UNIT ASSEMBLY, speedometer .....	85 — FXSB, FXEF
	16	67241—85	BRACKET, rear instrument mounting .....	N/A 85 — FXSB, FXEF
	17	67242—85	BRACKET, front instrument mounting .....	85 — FXSB, FXEF
	19	70941—84A	SPACER, rear instrument mounting (2) .....	85 — FXSB, FXEF
	20	92042—85	TACHOMETER, m.p.h. kit .....	85 — FXSB, FXEF
		92043—85	TACHOMETER, k.p.h. kit .....	85 — FXSB, FXEF
	21	92061—83	CUSHION, instrument (2) .....	85 — FXSB, FXEF
	22	92077—83	BRACKET, tachometer .....	85 — FXSB, FXEF

# CIRCUIT BREAKER AND BRAKE SWITCHES

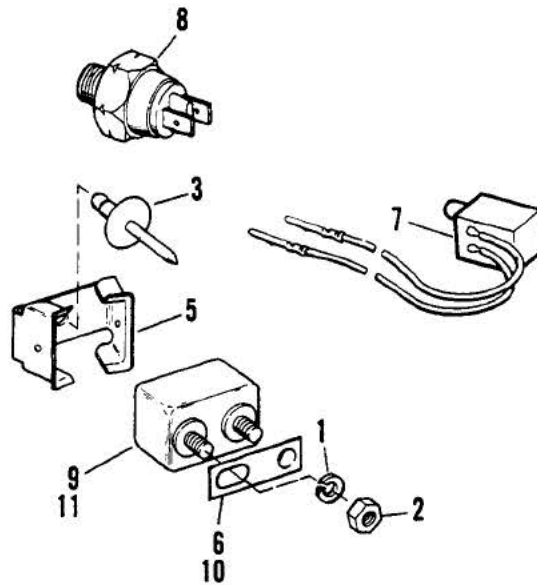

## CIRCUIT BREAKER AND BRAKE SWITCHES

FX49

RETAIL PRICE	INDEX NO.	PART NO.	NAME	USED ON
	1	7069	LOCKWASHER (6) .....	84 — FXST; 85 to * — All Models
	2	7638	NUT (6) .....	84 — FXST; 85 to * — All Models
	3	8483	POP RIVET, circuit breaker clip (3) .....	84 & 85 — FXST; 85 — All Models
		8672	POP RIVET, circuit breaker clip (3) .....	86 to * — FXWG, FXST
	5	9952	CLIP, circuit breaker (3) .....	84 — FXST; 85 to * — All Models
	6	69999—77	CONNECTOR BAR, circuit breaker to battery .....	85 to * — FXWG, FXSB, FXEF
	7	71574—82	STOPLIGHT SWITCH, with terminals & wiring .....	84 — FXST; 85 to * — All Models
	8	72023—51A	STOPLIGHT SWITCH, rear .....	84 — FXST; 85 to * — All Models
	9	74589—73	CIRCUIT BREAKER (3) .....	84 — FXST; 85 to * — All Models
	10	74598—73	CONNECTOR BAR, ignition & accessory circuit breakers .....	85 — FXSB, FXEF
	11	74599—77A	CIRCUIT BREAKER, battery .....	84 — FXST; 85 to * — All Models

## IGNITION SWITCH — FXWG, FXST

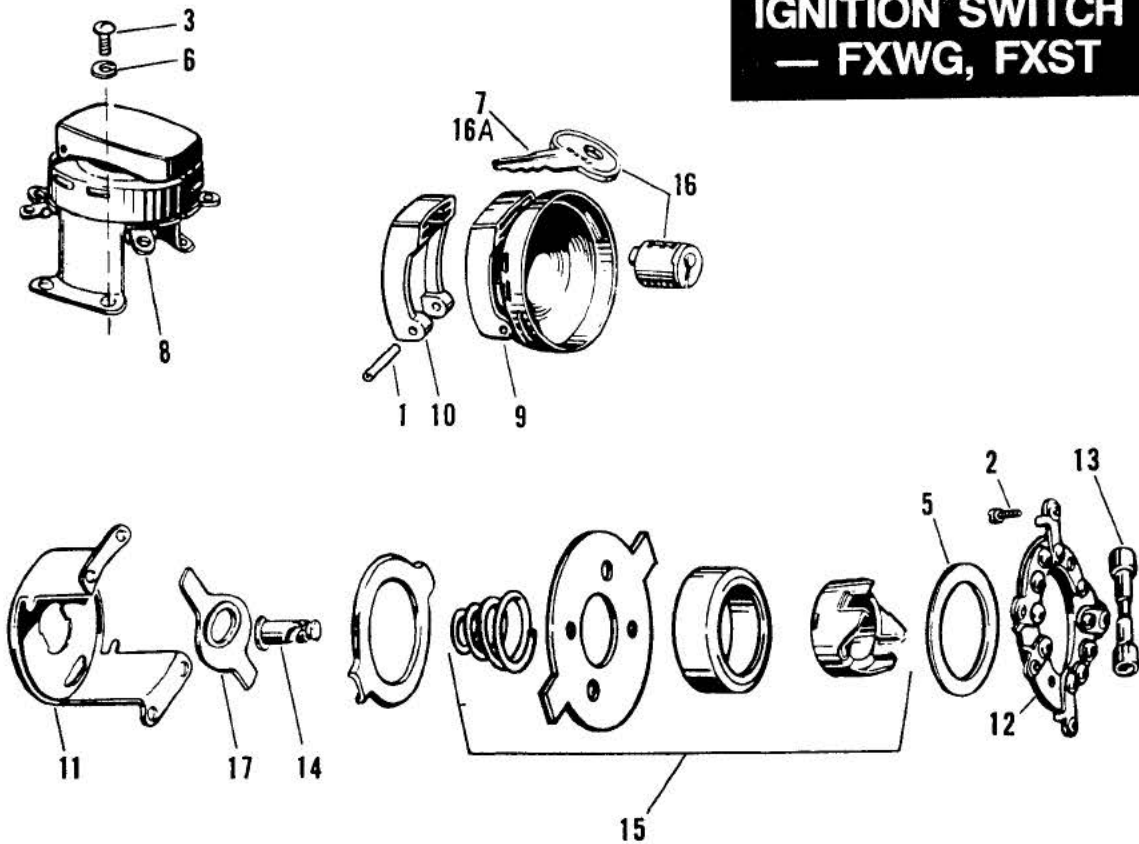

### IGNITION SWITCH — FXWG, FXST

**FX50**

RETAIL PRICE	INDEX NO.	PART NO.	NAME	USED ON
	1	612	ROLL PIN, keyhole cover	Early 84 — FXST
	2	2574W	SCREW	Early 84 — FXST
	3	2594	SCREW (4)	84 to * — FXST; 85 to * — FXWG
	5	6730	WASHER (Delrin)	Early 84 — FXST
	6	7015	LOCKWASHER (4)	84 to * — FXST; 85 to * — FXWG
	7	48155—30	KEY, ignition switch (specify letter & number of lock) (2)	Early 84 — FXST
	8	71501—73A	IGNITION AND LIGHT SWITCH, with lock	84 to * — FXST; 85 to * — FXWG
	9	71506—36A	SWITCH COVER	Early 84 — FXST
		71506—84	SWITCH COVER	Late 84 to * — FXST; 85 to * — FXWG
	10	71510—36A	KEYHOLE COVER, with roll pin	Early 84 — FXST
	11	71516—36	SWITCH BASE	N/A Early 84 — FXST
	12	71541—73	PLATE, switch mounting	Early 84 — FXST
		71541—84	PLATE, switch mounting	Late 84 to * — FXST; 85 to * — FXWG
	13	71560—36	CONTACT ROLLER	N/A Early 84 — FXST
		71560—84	CONTACT ROLLER	Late 84 to * — FXST; 85 to * — FXWG
	14	71562—36	RETAINER, contact roller	N/A Early 84 — FXST
	15	71572—44	CONTACT HOLDER	N/A Early 84 — FXST
	16	71580—36	SWITCH LOCK AND KEYS	N/A Early 84 — FXST
		71580—84	SWITCH LOCK AND KEY	Late 84 to * — FXST; 85 to * — FXWG
	16A	71583—85	KEY, ignition switch (specify number of lock)	Late 84 to * — FXST; 85 to * — FXWG
	17	71587—36	PLATE, switch lock	N/A Early 84 — FXST

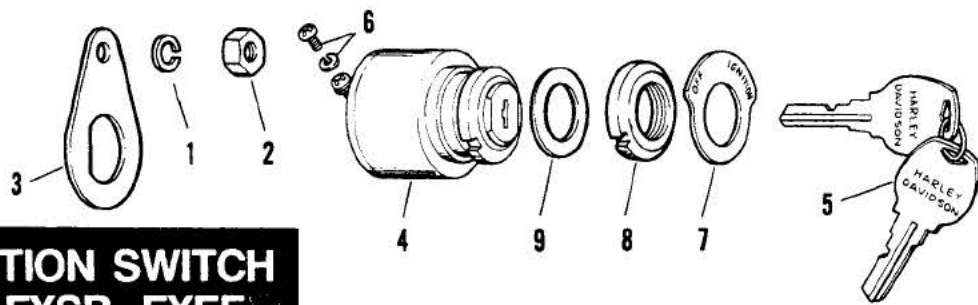

**IGNITION SWITCH  
— FXSB, FXEF**

RETAIL PRICE	INDEX NO.	PART NO.	N A M E	USED ON
	1	7036	LOCKWASHER . . . . .	85 — FXSB, FXEF
	2	7688	NUT . . . . .	85 — FXSB, FXEF
	3	69024—77	BRACKET, ignition switch (painted) . . . . .	85 — FXSB, FXEF
	4	71425—77	IGNITION AND LIGHT SWITCH, with keys . . . . .	85 — FXSB, FXEF
	5	71451—78	SET OF IGNITION SWITCH KEYS (specify serial no.) . . . . .	85 — FXSB, FXEF
	6	71518—80	SCREW, w/lockwasher (3) . . . . .	85 — FXSB, FXEF
	7	71550—75	LABEL, ignition switch . . . . .	85 — FXSB, FXEF
	8	71552—75	FACE NUT, ignition and light switch . . . . .	85 — FXSB, FXEF
	9	71554—75	WASHER, ignition and light switch . . . . .	85 — FXSB, FXEF



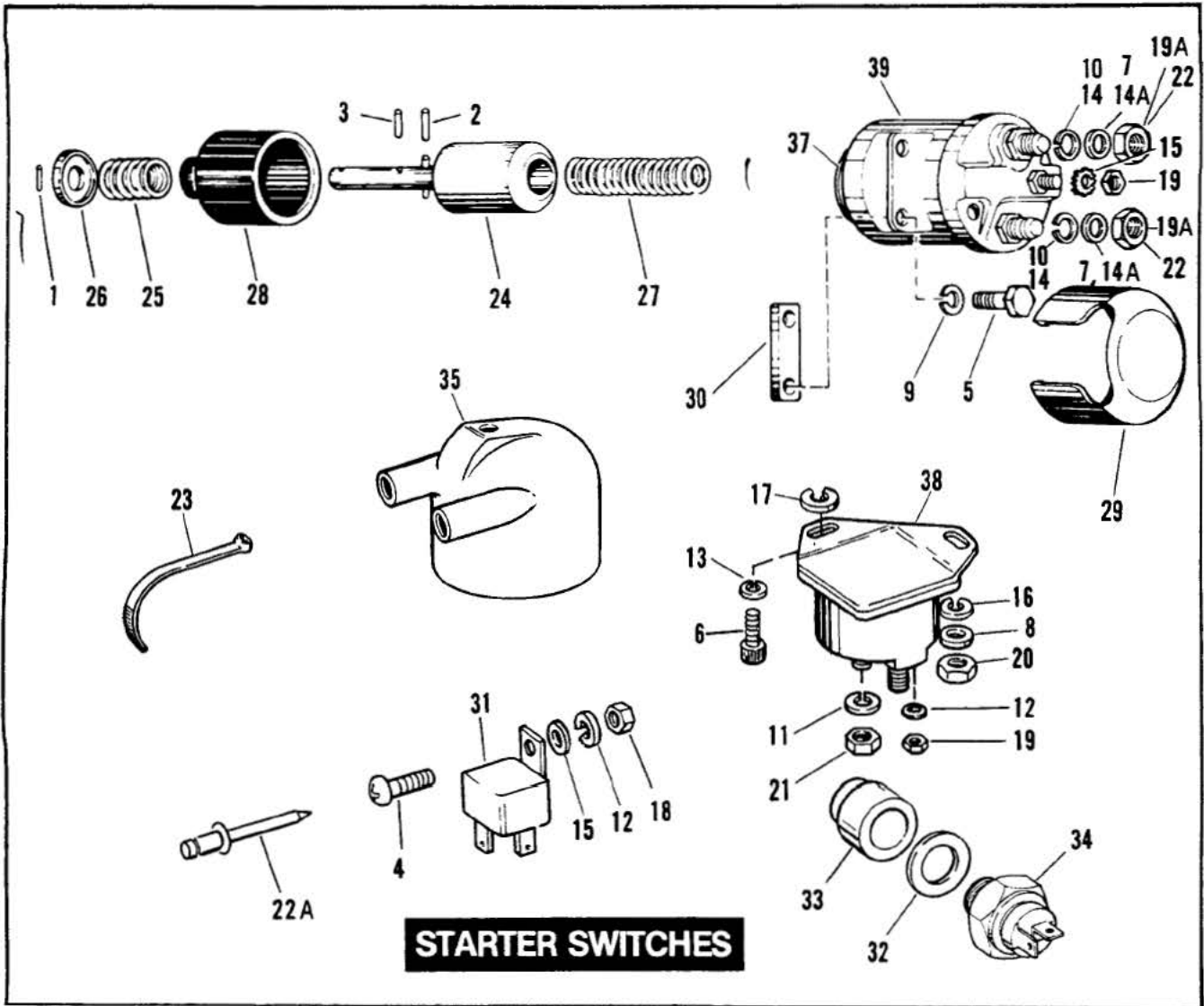

**STARTER SWITCHES**

# STARTER SWITCHES

FX51

RETAIL PRICE	INDEX NO.	PART NO.	NAME	USED ON
	~1	256	ROLL PIN .....	84 — FXST; 85 — All Models
		257	ROLL PIN .....	86 to * — FXWG, FXST
	~2	600	ROLL PIN .....	84 — FXST; 85 to * — All Models
	~3	613	ROLL PIN .....	84 — FXST; 85 to * — All Models
	4	2592	SCREW .....	84 — FXST
	5	3802W	BOLT (2) .....	84 — FXST; 85 to * — All Models
	6	4811	SCREW (2) .....	85 — FXWG, FXSB, FXEF
	7	6701	WASHER (2) .....	84 — FXST; 85 — All Models
	8	6703	WASHER (2) .....	85 — FXST
	9	7036	LOCKWASHER (2) .....	84 — FXST; 85 to * — All Models
	10	7038	WASHER (2) .....	85 — All Models
	11	7041	LOCKWASHER (2) .....	85 — All Models
	12	7069	LOCKWASHER (2 — 85) .....	84 — FXST; 85 — All Models
	13	7124	LOCKWASHER (2) .....	85 — FXWG, FXSB, FXEF
	14	7130W	LOCKWASHER (2) .....	84 — FXST; 85 — All Models
		7145W	LOCKWASHER (2) .....	86 to * — FXWG, FXST
	15	7220	LOCKWASHER (2 — 84 & 85) .....	84 — FXST; 85 to * — All Models
	16	7229W	LOCKWASHER (2) .....	Early 85 — FXST
	17	7230	LOCKWASHER (2) .....	85 — FXWG, FXSB, FXEF
	18	7620W	NUT .....	84 — FXST
	19	7638	NUT (2 — 84 & 85) .....	85 to * — All Models
	19A	7667	NUT (2) .....	Late 85 to * — All Models
	20	7686	NUT (2) .....	Late 85 — FXST
		7742	NUT (2) .....	Early 85 — FXST
	21	7748W	NUT (2) .....	Late 85 — All Models
		7763W	NUT (2) .....	Early 85 — All Models
	22	7783	NUT (2) .....	Early 85 — All Models
	22A	8672	POP RIVET, starter relay .....	86 to * — FXWG, FXST
	23	10006	CABLE STRAP .....	85 to * — All Models
	~24	31435—65B	PLUNGER ASSEMBLY, solenoid .....	84 — FXST; 85 to * — All Models
	~25	31438—65A	OVER-RUN SPRING .....	84 — FXST; 85 to * — All Models
	~26 -	31439—65A	RETAINER, over-run spring .....	84 — FXST; 85 — All Models
		31439—84	RETAINER, over-run spring .....	86 to * — FXWG, FXST
	~27	31440—65	RETURN SPRING, plunger .....	84 — FXST; 85 to * — All Models
	~28	31441—65A	RUBBER BOOT, solenoid plunger .....	84 — FXST; 85 to * — All Models
	29	31444—65A	COVER, solenoid switch (gray) .....	84 — FXST; 85 to * — All Models
	30	31452—65A	SPACER, solenoid mounting .....	84 — FXST; 85 to * — All Models
	31	31506—79B	STARTER RELAY (plastic) .....	84 — FXST; 86 to * — FXWG, FXST
	32	33043—80	WASHER, neutral switch .....	86 to * — FXST
	33	33198—79	BUSHING, neutral switch .....	84 & 85 — FXST; 85 to * — FXWG, FXSB, FXEF
	34	33900—59	TRANSMISSION NEUTRAL SWITCH .....	86 to * — FXST
		33901—79	TRANSMISSION NEUTRAL SWITCH .....	84 & 85 — FXST; 85 to * — FXWG, FXSB, FXEF
	35	69549—85	BOOT, relay .....	85 — FXWG, FXSB, FXEF
	37	71467—65	COVER GASKET, starter solenoid .....	84 — FXST; 85 — All Models
	38	71463—73A	STARTER RELAY .....	85 — All Models
	39	71469—65B	STARTER SOLENOID SWITCH .....	84 — FXST; 85 to * — FXWG, FXST

<b>RETAIL PRICE</b>	<b>INDEX NO.</b>	<b>PART NO.</b>	<b>NAME</b>	<b>USED ON</b>
NOTE: This kit is for 1985 and later FX model motorcycles sold for use in the state of California.				
3787			BOLT (5)	85 to * — All Models
6703			WASHER (6)	85 to * — All Models
7686			LOCKNUT (5)	85 to * — All Models
8625			POP RIVET	85 — All Models
10006			STRAP (6)	85 to * — All Models
10014			CLAMP	85 to * — All Models
27018—85			CLAMP	85 to * — All Models
27042—84			CANISTER	85 to * — All Models
27047—84			CANISTER BRACKET	85 to * — All Models
27065—85			HOSE FITTING, air cleaner	85 — All Models
27068—85			GASKET, air cleaner fitting	N/A 85 — All Models
27073—84A			HOSE, canister to tank	N/A 85 to * — All Models
27074—84			HOSE, canister to carburetor	85 to * — All Models
28800—85			HOSE, canister to air cleaner	85 — FXWG, FXSB, FXEF
28800—86			HOSE, canister to air cleaner	86 to * — FXST; 86 — FXWG
28801—85A			CLAMP, valve mounting	N/A 85 to * — All Models
28802—85			CLAMP, canister mounting	85 to * — All Models
28803—85			HOSE, canister to air cleaner	85 — FXST
28804—85			CLAMP, canister mounting	N/A 85 — All Models; 86 to * — FLST
28806—85			EVAPORATIVE EMISSIONS KIT, complete	N/A 85 — All Models
28814—86			EVAPORATIVE EMISSIONS KIT, complete	86 — FXWG
28827—86A			EVAPORATIVE EMISSIONS KIT, complete	N/A 86 to * — FXST, FXSTC, FLST
28832—86			HOSE, canister	N/A Late 86 to * — FXST, FXSTC, FLST
29058—77			GASKET, air cleaner	85 — All Models
29121—84			CAP, overflow	85 to * — All Models
29141—85			VENT TUBE, carburetor bowl	N/A 85 — All Models
29264—86			FITTING, air cleaner backplate	86 to * — FXST; Late 85 & 86 — FXWG
62150—85			VAPOR VALVE	85 to * — All Models

RETAIL PRICE	INDEX NO.	PART NO.	NAME	USED ON
<b>ENGINE</b>				
	16512—86A		CYLINDER WITH PISTON (black wrinkle) .....	86 to * — FXSTC
	16692—85B		CYLINDER HEAD, front (black wrinkle) .....	86 to * — FXSTC
	16696—85B		CYLINDER HEAD, rear (black wrinkle) .....	86 to * — FXSTC
	17528—84A		ROCKER COVER, outer .....	86 to * — FXSTC
	17529—84A		SPACER, rocker cover .....	86 to * — FXSTC
	17530—84B		ROCKER COVER, inner .....	86 to * — FXSTC
	18622—85A		TAPPET GUIDE, rear .....	86 to * — FXSTC
	18623—85A		TAPPET GUIDE, front .....	86 to * — FXSTC
	24493—85B		SET OF CRANKCASES .....	86 to * — FXSTC
	25268—84A		GEAR COVER (chrome) .....	86 to * — FXSTC
	26285—82		OIL PUMP COVER .....	86 to * — FXSTC
<b>TRANSMISSION HOUSING — 5 SPEED</b>				
	34468—86A		TRANSMISSION COVER (chrome) .....	86 to * — FXSTC
	34732—86A		TRANSMISSION HOUSING .....	86 to * — FXSTC
	35077—86A		BEARING HOUSING .....	86 to * — FXSTC
	37075—84		PLUG .....	86 to * — FXSTC
	37087—86		RELEASE LEVER, clutch .....	86 to * — FXSTC
	37104—84		CLUTCH RELEASE COVER (chrome) .....	86 to * — FXSTC
<b>REAR WHEEL</b>				
	3771		SCREW, sprocket .....	86 to * — FXSTC
	40221—85A		SPROCKET .....	86 to * — FXSTC
	40932—81		SPACER, sprocket .....	86 to * — FXSTC
	41057—83		DISC WHEEL .....	86 to * — FXSTC
<b>SEAT AND SISSYBAR</b>				
	1602		SCREW, backrest .....	86 to * — FXSTC
	2607		SCREW, backrest (2) .....	86 to * — FXSTC
	52191—86		BACKREST .....	86 to * — FXSTC
	52771—82		BRACKET, backrest .....	86 to * — FXSTC
	91768—85		SEAT .....	86 to * — FXSTC
	99000—77		MEDALLION .....	86 to * — FXSTC
<b>FRAME AND REAR FORK</b>				
	41556—86		REAR FORK .....	N/A 86 to * — FXSTC
<b>PRIMARY HOUSING</b>				
	60543—86		COVER ASSEMBLY (chrome) .....	86 to * — FXSTC
	60630—86A		HOUSING ASSEMBLY .....	86 to * — FXSTC
	60668—84B		CLUTCH COVER (chrome) .....	86 to * — FXSTC

<b>RETAIL PRICE</b>	<b>INDEX NO.</b>	<b>PART NO.</b>	<b>NAME</b>	<b>USED ON</b>
<b>FUEL TANK</b>				
		14145—86	DECAL, scroll, left side .....	86 to * — FXSTC
		14146—86	DECAL, scroll, right side .....	86 to * — FXSTC
<b>OIL FILTER</b>				
		63796—77A	OIL FILTER (chrome) .....	86 to * — FXSTC
<b>EXHAUST SYSTEM</b>				
		65460—86	SUPPORT TUBE ASSEMBLY .....N/A	86 to * — FXSTC
<b>BATTERY</b>				
		66042—79A	WARNING LABEL .....	86 to * — FXSTC
<b>INSTRUMENT PANEL</b>				
		67067—76	ISOLATOR STRIP, black .....	86 to * — FXSTC
		71241—68B	INSTRUMENT PANEL KIT (chrome) .....	86 to * — FXSTC
		71243—86	INSTRUMENT PANEL KIT (candy burgundy) .....	86 to * — FXSTC
<b>STARTER SOLENOID SWITCH</b>				
		31475—77	SOLENOID COVER (black) .....	86 to * — FXSTC
		71473—77B	STARTER SOLENOID SWITCH .....	86 to * — FXSTC

RETAIL PRICE	INDEX NO.	PART NO.	NAME	USED ON
<b>AIR CLEANER</b>				
		29161—86	TRIM, air cleaner "Heritage Softail" .....	86 to * — FLST
<b>FOOT GEAR SHIFTER</b>				
		1719W	SCREW, shifter lever .....	86 to * — FLST
		2773	SCREW, shifter lever .....	86 to * — FLST
		4812	SCREW, shifter lever (2) .....	86 to * — FLST
		7230	LOCKWASHER, shifter lever .....	86 to * — FLST
		9851	FITTING, shifter lever .....	86 to * — FLST
		33630—70	BRACKET, shifter & footboard .....	86 to * — FLST
		33642—89	COVER ASSEMBLY, shifter (chrome) .....	86 to * — FLST
		33668—86	SHIFTER LEVER (chrome) .....	86 to * — FLST
		33895—82	SHIFTER LEVER (chrome) (2) .....	86 to * — FLST
		34611—65	PEG, shifter lever (2) .....	86 to * — FLST
<b>CLUTCH HAND CONTROL</b>				
		38611—86	CABLE, clutch control .....	86 to * — FLST
<b>FRONT BRAKE CONTROL</b>				
		923	SCREW, front brake hose .....	86 to * — FLST
		8108	SPEED NUT, front brake hose (2) .....	86 to * — FLST
		41713—86	CLIP, front brake hose (2) .....	86 to * — FLST
		42305—86	HOSE, front brake .....	86 to * — FLST
<b>REAR BRAKE CONTROL</b>				
		2718	SCREW, rear brake adjuster .....	86 to * — FLST
		3419	BOLT, cylinder decorative cover (2) .....	86 to * — FLST
		3767B	BOLT, rear brake hose .....	86 to * — FLST
		4411	BOLT, brake tee mounting .....	86 to * — FLST
		4713W	BOLT, foot brake lever support .....	86 to * — FLST
		6516W	WASHER, brake lever .....	86 to * — FLST
		6702	WASHER, cylinder decorative cover (4) .....	86 to * — FLST
		7038	LOCKWASHER, foot brake lever support .....	86 to * — FLST
		7688	NUT, rear brake adjuster (2) .....	86 to * — FLST
		7740	NUT, master cylinder cover (2) .....	86 to * — FLST
		7825	NUT, brake lever (2) .....	86 to * — FLST
		8108	SPEED NUT, rear brake hose .....	86 to * — FLST
		36962—67	SPACER, brake pedal .....	86 to * — FLST
		36964—67	PAD, brake pedal .....	86 to * — FLST
		40957—86	BRAKE HOSE, rear .....	86 to * — FLST
		41713—86	CLIP, rear brake hose .....	86 to * — FLST
		41745—79	DECORATIVE COVER, cylinder (chrome) .....	86 to * — FLST
		42269—70	PIN, rear brake rod clevis .....	86 to * — FLST
		42301—79A	STUD, master cylinder .....	86 to * — FLST
		42375—82	BOLT, master cylinder cover (2) .....	86 to * — FLST
		42381—82	COVER, rear brake master cylinder (polished) .....	86 to * — FLST
		42407—86	FOOT BRAKE LEVER (chrome) .....	86 to * — FLST
		42431—86	SUPPORT, foot brake lever .....	86 to * — FLST
		42453—82A	MASTER CYLINDER (black) .....	86 to * — FLST
		42455—82	GASKET, master cylinder reservoir .....	86 to * — FLST
		50992—86	PLUNGER, master cylinder .....	86 to * — FLST
		57215—75	BUSHING, foot brake lever .....	86 to * — FLST

RETAIL PRICE	INDEX NO.	PART NO.	NAME	USED ON
--------------	-----------	----------	------	---------

**SPOKE WHEEL — FRONT**

	11173		O-RING .....	86 to * — FLST
	11175		RETAINING RING .....	86 to * — FLST
	41584—86		AXLE .....	86 to * — FLST
	43005—86		FRONT WHEEL ASSEMBLY, 16" .....	86 to * — FLST
	43053—86		HUB, with bearings, seals & spacers .....	86 to * — FLST
	43067—86		CAP, hub, 8-1/4" (chrome) .....	86 to * — FLST
	43085—81		RIM, front wheel, 16" (chrome) .....	86 to * — FLST
	43654—86A		SPACER .....	86 to * — FLST

**FRONT FORK**

	923		SCREW, rear panel mounting (2) .....	86 to * — FLST
	2417		SCREW, slider cover (4) .....	86 to * — FLST
	3953W		BOLT, front panel mounting (2) .....	N/A
	4095		SCREW, panel mounting (4) .....	86 to * — FLST
	4371W		SCREW, center-rear pinch bolt .....	86 to * — FLST
	4453		BOLT, stem & bracket .....	86 to * — FLST
	6655		WASHER, stem & bracket .....	86 to * — FLST
	7041		LOCKWASHER, front panel mounting (2) .....	86 to * — FLST
	7124		LOCKWASHER, slider cover (4) .....	86 to * — FLST
	14150—86		WARNING LABEL .....	86 to * — FLST
	45456—86		BRACKET, upper .....	86 to * — FLST
	45603—86		STEM AND BRACKET .....	86 to * — FLST
	45611—86		RETAINING RING, fork stem .....	86 to * — FLST
	45762—86		FRONT FORK ASSEMBLY .....	86 to * — FLST
	45915—86		FORK AND SLIDER TUBE ASSEMBLY, right .....	86 to * — FLST
	45916—86		FORK AND SLIDER TUBE ASSEMBLY, left .....	86 to * — FLST
	45917—86		SLIDER, right .....	86 to * — FLST
	45918—86		SLIDER, left .....	86 to * — FLST
	45930—86		SLIDER TUBE (2) .....	86 to * — FLST
	45931—86		SPRING (2) .....	86 to * — FLST
	45932—86		DAMPER TUBE (2) .....	86 to * — FLST
	45933—86		SPRING, damper tube (2) .....	86 to * — FLST
	45934—86		BUSHING, brake caliper .....	86 to * — FLST
	45964—86		COVER, slider (stainless steel) (2) .....	86 to * — FLST
	50991—86		BRACKET, front panel (2) .....	86 to * — FLST
	67808—86		FRONT PANEL (buffed stainless steel) .....	86 to * — FLST
	67816—86		BACK PANEL, left — rear .....	86 to * — FLST
	67819—86		TRIM STRIP, front panel (2) .....	86 to * — FLST
	67820—86		BACK PANEL, right rear .....	86 to * — FLST

**FRAME & REAR FORK**

	7783		NUT, rear axle adjuster (2) .....	86 to * — FLST
	47574—86		REAR FORK (black) .....	86 to * — FLST
	47577—86		SPACER, rear axle adjuster (2) .....	86 to * — FLST
	47579—86		ADJUSTER, rear axle (2) .....	86 to * — FLST

RETAIL PRICE	INDEX NO.	PART NO.	NAME	USED ON
<b>JIFFY STAND</b>				
		2882W	BOLT, jiffy stand	86 to * — FLST
		4730	BOLT, jiffy stand (2)	86 to * — FLST
		7753	NUT, jiffy stand	86 to * — FLST
		50007—86	JIFFY STAND ASSEMBLY (chrome)	N/A
		50018—85	BRACKET, jiffy stand	86 to * — FLST
		50087—86	LEG, jiffy stand	86 to * — FLST
<b>SEAT</b>				
		52502—86	SEAT (black)	86 to * — FLST
<b>FOOTBOARDS</b>				
		4721	BOLT, left footboard support	86 to * — FLST
		6448HB	WASHER, left footboard support	86 to * — FLST
		7038	LOCKWASHER, left footboard support	86 to * — FLST
		7742	LOCKNUT, footboard mounting (4)	86 to * — FLST
		50614—66	PAD, footboard (2)	86 to * — FLST
		50619—74A	UPPER PLATE, footboard (chrome) (2)	86 to * — FLST
		50620—74	MOUNT, footboard (rubber) (8)	86 to * — FLST
		50621—79A	FOOTBOARD ASSEMBLY (chrome) (2)	86 to * — FLST
		50635—82	BOLT, footboard hinge (4)	86 to * — FLST
		50989—86	STUD, footboard support — left front (chrome)	86 to * — FLST
		50990—86A	SUPPORT BRACKET, footboard — left rear	86 to * — FLST
<b>HANDLEBAR</b>				
		7739	NUT, handlebar risers (4)	86 to * — FLST
		7844	NUT, handlebar mounting (2)	86 to * — FLST
		56105—84	STUD, handlebar	86 to * — FLST
		56133—83	COVER, handlebar clamp — upper (chrome)	86 to * — FLST
		56541—86	CLAMP, handlebar — lower left (chrome)	86 to * — FLST
		56542—86	CLAMP, handlebar — lower right (chrome)	86 to * — FLST
		56567—86	CLAMP, handlebar — center (chrome)	86 to * — FLST
		56569—86	HANDLEBAR	86 to * — FLST
		70197—86	CABLE, handlebar ground	86 to * — FLST
<b>FENDERS AND REAR BELT OR CHAIN GUARD</b>				
		2531	SCREW, skirt trim — front fender (8)	86 to * — FLST
		2604	SCREW, front and rear fender lamps (4)	86 to * — FLST
		3485	SCREW, front fender mounting (4)	86 to * — FLST
		3560W	TEE BOLT, front fender trim (2)	86 to * — FLST
		3561WB	TEE BOLT, front fender trim (2)	86 to * — FLST
		3767B	BOLT, wire assembly — rear fender	86 to * — FLST
		6335	WASHER, skirt trim — front fender (2)	86 to * — FLST
		7036	WASHER, cable bracket	86 to * — FLST
		7118	LOCKWASHER, front and rear fender lamps (8)	86 to * — FLST
		7220	LOCKWASHER, front fender trim (4)	86 to * — FLST
		7230	LOCKWASHER, wire assembly — rear fender (2)	86 to * — FLST
		7501	NUT, wire assembly — rear fender (2)	86 to * — FLST
		7531	NUT, front fender mounting (4)	86 to * — FLST
		7613A	SCREW, trim — front fender (6)	86 to * — FLST
		7624	NUT, front fender trim (4)	86 to * — FLST
		7638	NUT, front and rear fender lamps (4)	86 to * — FLST
		7775	LOCKNUT, rear fender support (2)	86 to * — FLST
		8131W	LOCKNUT, skirt trim — front fender (8)	86 to * — FLST
		8505	RIVET, cable bracket	86 to * — FLST
		10033	CLAMP, wire assembly — rear fender	86 to * — FLST



RETAIL PRICE	INDEX NO.	PART NO.	NAME	USED ON
<b>FENDERS AND REAR BELT OR CHAIN GUARD (CONT'D)</b>				
	11430		GROMMET, wire assembly — rear fender	86 to * — FLST
	11437		GROMMET, wire assembly — rear fender	86 to * — FLST
	14142—86		TRIM, "Heritage Softail" — front fender (2)	86 to * — FLST
	38622—87		BRACKET, cable	86 to * — FLST
	53439—79		BULB, front & rear fender lamps (2)	86 to * — FLST
	58993—86		FRONT FENDER (red)	86 to * — FLST
	59082—79		LAMP ASSEMBLY, front fender	86 to * — FLST
	59126—86B		REAR FENDER (prime)	86 to * — FLST
	59129—86		FRONT FENDER (prime)	86 to * — FLST
	59180—80		LENS, front fender lamp	86 to * — FLST
	59181—80		GASKET, front fender lamp	86 to * — FLST
	59191—86		REAR FENDER (red)	86 to * — FLST
	59197—86		WIRING HARNESS, front fender lamp	N/A 86 to * — FLST
	59210—86		TRIM SKIRT, front fender (red)	86 to * — FLST
	59211—74		SIDE TRIM, front fender (2)	86 to * — FLST
	59235—86		TRIM SKIRT, front fender (black)	86 to * — FLST
	59658—79		LAMP ASSEMBLY, rear fender	86 to * — FLST
	59964—86		FENDER SUPPORT, right — rear fender (chrome)	86 to * — FLST
	59969—86		FENDER SUPPORT, left — rear fender (chrome)	86 to * — FLST
	68046—79		LENS, rear fender lamp	86 to * — FLST
	68047—79		GASKET, rear fender lamp	86 to * — FLST
	70196—86		WIRE ASSEMBLY, front fender	86 to * — FLST
	72044—71		CONNECTOR, single socket — front fender	86 to * — FLST
<b>LICENSE PLATE BRACKETS</b>				
	2774		SCREW, license plate bracket (3)	86 to * — FLST
	7036		LOCKWASHER, license plate bracket (3)	86 to * — FLST
	7688		NUT, license plate bracket (3)	86 to * — FLST
	59626—84		BRACKET ASSEMBLY, license plate (black)	86 to * — FLST
	59984—73		BRACKET, license plate	86 to * — FLST
	59986—75		SUPPORT BRACKET, license plate	86 to * — FLST
	60001—55		CLAMP, license plate	86 to * — FLST
<b>FUEL TANK</b>				
	14143—86		DECAL (silver) (2)	86 to * — FLST
	14144—86		DECAL (red, gold)	86 to * — FLST
	61218—85A		FUEL TANK, right (prime)	86 to * — FLST
	61426—85		FUEL TANK, left (prime)	86 to * — FLST
	61913—86		FUEL TANK, left (signal red & creme w/p.s.)	86 to * — FLST
	61915—86		FUEL TANK, right (signal red & creme w/p.s.)	86 to * — FLST
<b>EXHAUST SYSTEM</b>				
	10074		CLAMP, front shield	86 to * — FLST
	65447—86		SHIELD, front exhaust (chrome)	86 to * — FLST
<b>HEADLAMP</b>				
	67713—86		BULB, headlamp	86 to * — FLST
	67768—86		MOUNTING BLOCK, headlamp	86 to * — FLST
	67825—86		HEADLAMP, complete — with wiring	86 to * — FLST

RETAIL PRICE	INDEX NO.	PART NO.	NAME	USED ON
<b>TURN SIGNALS</b>				
	2692W		SCREW, rear turn signal mounting (4) .....	86 to * — FLST
	7069		LOCKWASHER, rear turn signal mounting (4) .....	86 to * — FLST
	68402—86		LAMP WITH WIRE, rear — 12 V. (amber) (2) .....	86 to * — FLST
	68440—86		LENS, rear turn signal (2) .....	86 to * — FLST
	68451—86		O-RING, rear turn signal lens (2) .....	86 to * — FLST
	68510—74B		MOUNTING BRACKET, rear turn signals .....	86 to * — FLST
	72044—71		CONNECTOR, single socket — rear turn signal (3) .....	86 to * — FLST
<b>SPEEDOMETER &amp; INSTRUMENT PANEL</b>				
	67067—76		ISOLATOR STRIP, speedometer head .....	86 to * — FLST
	67079—86A		CABLE, speedometer .....	86 to * — FLST
	67125—86A		DRIVE UNIT, speedometer .....	86 to * — FLST
	71241—68B		INSTRUMENT PANEL (chrome) .....	86 to * — FLST

## NUMERICAL INDEX

Part No.	Page	Part No.	Page	Part No.	Page	Part No.	Page	Part No.	Page
215	30		125		139	3431	5		17
239	13	1601	10	2774	97	3485	141		81
256	135		21		142	3486	85		93
257	135	1602	84	2779	125	3491	49		101
275	10		137	2813	30	3494	15		103
334 A	23	1719 W	117	2823	71	3500	5		107
	25		159		73	3501	5	3991	93
	99	1783	50		75	3504	8		95
335	41	2005	93	2851	19	3505	8	3993	21
336	41		95		77	3509	57		25
358	8	2216 W	19		79	3512	8		30
	10	2337 W	99		87	3514	111		33
375	37	2356	99	2871 W	15	3516	85	3996	33
	41	2417	140		99	3517	55	3997	5
	99	2508	123		112	3520	61	4013	93
513	61	2511	10	2872 W	13	3525	61	4014 W	35
515	35	2531	141		23	3545	99		83
	57	2551 W	23		30	3550 W	141		95
	59		35		57	3561 WB	141		101
553	61	2574 W	125	2879 W	19	3559 A	93	4015	49
600	135		131		85	3655	63		53
601	33	2579	53		86		65	4017	15
609	41	2583	93		87	3728	79		17
612	131		111		93	3767 B	79		27
613	135		119		95		81		99
618	109	2585	49	2881 W	30		84		107
634	41	2592	135		47		139	4021	99
650	30	2594	125	2582 W	81		141	4036	95
653	6		131		93	3768	25		107
	10	2602	97		141	3770	5	4068	99
700	13	2604	141	2887 W	25	3771	50		125
705 A	103	2607	84		57		69		129
	105		137		88		137	4069	115
707	37	2608	86	2889	115	3782	50	4070	115
720	8	2611 B	21	2904	115		67	4079	38
721	33	2614	50	3003	95	3784	33	4092	101
728	79	2630 W	125	3210	17	3787	15		129
	81	2653	19		41		17	4095	140
738	17	2659	21		95		109	4319	77
739	41	2662 W	53	3409	101		136		79
	99		119	3415	35	3789 A	30		81
855 A	55	2664	29	3419	125		37		84
856	33	2665	21		139	3802 W	19	4337 W	57
857	39	2667	57	3427	8		30		77
	41		88	3429	13		135		79
	50	2682	27	3430	8	3825	57		85
864	17	2692 W	143	3440	81	3826	21	4371 W	73
884	5	2698	115	3443	95	3839 W	86		75
923	101	2711	84	3444	53	3945	111		140
	129	2712	19	3450	90	3953 W	140	4391	21
	139	2718	139	3464	57	3958	89		93
	140	2722	79	3471	90	3960 W	83		103
924	99	2731 W	21	3473	21	3974 HW	95		109
	101	2757 W	84		57		103	4392	59
1203	112	2773	101		59	3987	3	4401 W	8

# NUMERICAL INDEX

Part No.	Page	Part No.	Page	Part No.	Page	Part No.	Page	Part No.	Page
	50	4951	81		59		73		25
4411	73	4969	79		109		75		27
	75	5403 B	97	6235	97		77		31
	139	5410	71	6237	101		79		35
4412	111		111	6242 W	10		81		47
4415	8	5423	95		21		83		57
4420	107	5444	50	6324 W	99		93		64
4435 W	8	5465	97	6333	95		95		66
4453	140	5710	71	6334	83		101		97
4640	95	5714	117		95		109		105
4713 W	19	5775	101	6335	141		117		109
	57	5891	59	6365	101		139		133
	59	5926 B	93	6375 B	35	6703	25		135
	139		95	6377	13		27		141
4716 W	29	5960 W	89	6379 W	3		31		142
	93	6002	17		93		50	7038	19
	95	6003	43		95		53		29
4717	41	6016	3	6388 HB	99		79		37
4718	41		5	6400 HB	8		81		50
4719 W	107		8		50		97		57
4720 W	95		15	6409	35		105		59
	99		17	6410	84		135		77
4721	57		25	6443 HW	29		135		79
	85		27		37	6715	21		85
	86		29		45		27		86
	87		33	6448 HB	141		57		87
	95		37	6474	37		95		95
	141		41		81		97		111
4722	95		99	6497 HW	3	6718	87		115
	99	6019	3		21		89		135
	107		55		33		90		139
4724	57		81	6506	7	6724	88		141
	59	6026	77	6515 HW	3	6730	131	7039	3
	73		79		21	6736	5		21
	75	6029	93		50		13		37
	77		95		67		31		45
	81	6099	5		69		33		71
	111		10		139		37		83
4726	3		21	6590 HW	63	6737	5		95
	21		37	6653	63	6750	31	7041	21
	50		41		65	6752	31		25
	67		47	6655	61	6762 B	5		27
4729	71		49		67	6771	15		29
4730	141		53		59	7010	125		35
4740	10		99		140	7015	117		37
4741	25	6107 B	95	6701	79		125		41
4810	10		109		84		131		71
4811	135	6109	17		87	7022	61		73
4812	139	6115	61		89		63		75
4813	10	6185	30		95		65		83
	21	6192	125		111		67		88
	99	6194	10		135		69		93
4814	41		21	6702	17	7036	13		95
4815	41	6220 W	35		35		21		101
4816	90		57		71		23		103

# NUMERICAL INDEX

Part No.	Page	Part No.	Page	Part No.	Page	Part No.	Page	Part No.	Page
	112		139		136	7775	3		139
	117		141	7688	19		9		139
	125	7232	17		27		31	8123	79
	129		71		97		39	8125	117
	135		111		105		99	8126	105
	140		125		109		141	8131 W	141
7042	115	7501	113		133	7776 W	3	8155	125
7045	115		141		139		57	8227	45
7053	63	7506	9		142		61	8241	29
	65	7507	81	7689 W	81		85	8483	79
	67		93		97	7778	50		95
	90	7508	83		105		57		97
	112	7513	83	7725	77		67		103
7069	10	7515	33		79		85		125
	21	7523	29		101		86		130
	27		37	7736	35		87	8490	115
	130	7531	95		83	7782	81	8505	141
	135		141		93	7733	57	8519	93
	143	7561	50		117		59		95
7115	49		67	7739	3		67		112
7118	21	7572 W	86		63		135		115
	27	7602	125		86		140		125
	141	7606	111		141	7800 W	3	8625	136
7124	19	7608	49	7740	17		37	8672	103
	79		117		90		49		115
	81	7613 A	141		139		77		125
	135	7614	112	7742	57		86		130
	140	7620 W	27		79		111		135
7127	57		135		135	7813	63	8592	81
	59	7624	27		141		65		93
	101		97	7744	17	7825	50		95
7130 W	77		119		33		67	8698	105
	79		141		35		139	8699	10
	135	7628	61		57	7827 W	50		21
7142	79		89		59		67	8860	29
	81	7633	107		125	7837 W	37	8873	13
7143	49	7634	10	7748 W	41		45	8876 A	43
7145 W	19	7638	17		71	7844	141	8904	43
	79		21		73	7845	63	8906	39
	81		93		75	7848 W	47	8977	41
	135		125		103		95	8996	41
7220	27		130		107	7851 W	49	8998	41
	29		135		117	7880	87	9008	21
	53		141		135		112	9020	37
	93	7643 W	77	7753	9	7911	29	9028	9
	111		79		17	7977	29	9052	63
	112	7667	135		21	7986	61		65
	119	7680 W	93		29		67		67
	135		95		35		69		69
	141	7683	21		37	7993	89		77
7229 W	109		57		107	8102	17	9058	10
	125	7686	97		141	8103	79	9061	99
	135		103	7763 W	135		81	9062	23
7230	27		105	7767	81		101		25
	135		135	7768 W	90		129	9063	23

## NUMERICAL INDEX

Part No.	Page	Part No.	Page	Part No.	Page	Part No.	Page	Part No.	Page
	99	9866	121		21	11157	5	16284-84	3
9076	79	9871	121	10048	107	11158	79	16302-81	9
	81	9875	121	10049	103		81	16478-83	3
9114	33		123	10053	53	11159	103	16478-85A	3
9115	33	9881	21	10059	49	11160	9	16480-83	3
9120	9	9885	21	10065	90	11161	41	16480-85A	3
9121	9	9898	121		111	11165	41	16482-83	3
9122	9		123		113		43	16482-85	3
9123	9	9900	21		121	11166	39	16510-83	3
9124	9		121		123	11171	31	16512-86A	137
9125	9	9905	121		125	11173	140	16573-83	3
9126	9	9914	121	10067	109	11175	140	16690-85B	3
9127	9	9931	111	10073	121	11218	7	16691-85B	3
9128	9		121	10074	142	11410	115	16692-85B	137
9129	9	9937	121	10078	121	11411	93	16696-85B	137
9130	9	9945	121	10079	103		95	16715-83	3
9131	9	9952	95	10080	9	11430	125	16773-85	3
9132	9		103		103		142	16774-86A	3
9133	9		112		105	11437	142	16778-84	5
9134	9		115	10081	53	11442	115	16779-84A	5
9135	99		125	11000	37	11446	103	16830-29A	3
9181	7		130		45	11447	101	16830-54	37
9182	7	9955	107	11002	10	11448	112	16831-83	3
9183	7	9969	103		13	11449	115	16837-83	3
9184	7	9991 A	15	11007	9	11451	81		9
9185	7	10003	88	11013	17	11469	79	16837-85A	3
9186	7	10006	17	11016	31	11729	35	16852-83A	3
9217	9		19		33	11733	37	17033-83A	3
9218	9		21		35		41		5
9219	9		88	11019	41	12010	31	17035-83B	3
9221 A	9		90	11020	41	12013 A	39		5
9222 A	9		91	11031	29		43	17355-84A	5
9223 A	9		103		35	12014	45	17356-84A	5
9224 A	9		111	11036	31	12018	99	17358-84A	5
9225 A	9		113	11039	23	12026 B	9	17360-83	5
9441 A	7		117		25	12045	33	17375-83	5
9443 A	7		121	11041	23	12050	41	17428-57	5
9444 A	7		135	11067	43	12051	41	17503-84A	5
9445 A	7		136	11083	33		99	17510-84	5
9446 A	7	10007	121	11096	43	12052	99	17521-84B	5
9450 A	7		123		45	14061-84	101	17528-84A	137
9540 A	45	10014	15		47	14062-84	101	17529-84A	137
9851	35		41	11101	23	14063-84	101	17530-84B	137
	77		101		29	14064-84	101	17611-83	5
	139		136	11105	10	14072-84	101	17921-83	5
9856	121	10031	53		13	14073-84	101	17922-83	5
9857	21	10033	57	11115	39	14123-86	101	17923-83	5
	111		141	11132	5	14124-86	101	17924-83	5
	121	10036	57	11143	49	14125-86	101	17925-83	5
9858	121		61		53	14142-86	142	17926-83	5
9860	121	10038	57	11145	5	14143-86	142	17927-83	5
9862	19		59	11147	99	14144-86	142	17928-83	5
	121	10039	27	11150	33	14145-86	138	17929-83	5
9863	121		121	11155	91	14146-86	138	17930-83	5
9864	121	10046	10		123	14150-86	140	17931-83	5

## NUMERICAL INDEX

Part No.	Page	Part No.	Page	Part No.	Page	Part No.	Page	Part No.	Page
17932-83	5	24033-70	9	25268-84A	137	26338-68	13	27365-76	15
17935-79B	5		51	25275-82	11	26345-73	11	27367-76	15
17938-83	5	24034-70	9	25313-77B	11	26346-70	11	27368-76	15
17945-36B	5		51	25320-82	11		13	27369-76	15
17947-36	5	24035-70	9	25321-82	11	26348-15	7	27370-83	15
17950-66	5		51	25322-82	11		11	27371-76	15
18001-83A	3	24036-70	9	25323-82	11		13	27335-76	15
18010-83	3		51	25325-82	11	26348-36	13	27450-82	17
18020-83	3	24037-70	9	25326-82	11	26349-73A	11	27451-82	17
18074-83A	3		51	25327-82	11	26349-84	11	27499-85	15
18076-83	3	24040-70	11	25328-82	11	26400-82	13	27885-78	15
18082-83	3	24041-78	11	25405-82	9	26432-76A	3	27887-78	15
18087-83	3	24042-78	11	25414-70A	99	26558-84	3	27888-78	15
18130-83C	3	24043-78	11	25416-70	99		15	27891-80	15
18131-83C	3	24044-78	11	25416-84	99	26561-84	11	27898-78	15
18133-83A	3	24045-78	11	25536-84	11	27008-83A	15	28800-85	136
18201-83	3	24046-78	11	25537-84	11	27012-83A	15	28800-86	136
18202-83	3	24281-83	7	25538-84	11	27018-85	136	28801-85	136
18219-83	3	24334-36	7	25539-84	11	27019-83	15	28802-85	136
18222-83	3	24335-36	7	25544-84	11	27023-71	15	28803-85	136
18229-83	3	24345-36A	7	25545-84	11	27029-83D	15	28804-85	136
18523-86	5	24346-87	7	25546-84	11	27029-86B	15	28806-85	136
18540-83A	5	24356-35A	7	25550-36	11	27042-84	136	28814-85	136
18542-83A	5	24355-71	7	25550-57	11	27047-84	136	28827-86	136
18622-85A	137	24367-71	7	25551-36	11	27065-85	136	28827-86A	136
18623-85A	137	24385-40B	7	25552-36	11	27068-85	136	28832-86	136
18633-48C	5	24387-40B	7	25553-36	11	27073-84A	136	29058-77	15
18634-43B	5	24388-40B	7	25554-36	11	27074-84	136		17
21920-83	7	24389-40B	7	25555-36	11	27079-84	15		136
21921-83	7	24390-40B	7	25555-54	11	27130-81	15	29068-86	17
21922-83	7	24391-40B	7	25556-79	11	27136-81	15	29110-83	17
21923-83	7	24493-85B	137	25557-79	11	27137-81	15	29116-83	15
21924-83	7	24546-83C	9	25558-79	11	27139-81	15		17
21940-83	7	24553-83	9	25559-79	11	27143-81	15	29121-84	136
21941-83	7	24582-83A	11	25581-70	11	27144-83	15	29126-83	17
21942-83	7	24599-58A	9	25582-73	11	27144-86A	15	29134-83A	17
21943-83	7	24600-58A	9	25715-47	31	27145-81	15	29134-86	17
21944-83	7	24601-58A	9	26190-73	13	27301-86	15	29141-85	136
22589-83	7	24641-36	11	26207-83	13	27302-84	15	29145-84	17
22764-83	7	24645-81	9	26216-84	13	27304-76	15	29145-86	17
23905-78G	7	24649-81	9	26227-58	13	27307-76	15	29161-86	139
23909-80	7	24650-81	9	26231-78	103	27308-76	15	29165-83A	17
23961-80A	7	24651-58	9	26242-84	13	27309-76	15	29168-83A	17
23969-83	7	24652-58	9	26247-78	13	27311-76	15	29169-84	17
23974-87	7	24653-58	9	26262-80	13	27324-83	15	29172-85	17
23975-87	7	24654-58	9	26263-80	11	27325-83	15	29173-85	17
23985-54	7	24655-58	9		13	27325-86	15	29175-85	17
	11	24692-58	9	26273-80B	13	27327-83	15	29211-86	17
24002-70	9	24703-54B	11	26276-80A	13	27329-83	15		125
24006-83	7	24823-80	37	26277-84	13	27330-83	15	29213-79	17
24016-80	7		39	26315-68A	13	27333-76	15		125
24017-80	7	24981-70	11	26317-68A	13	27335-76	15	29214-71	17
24023-54	11	24982-70	11	26326-62A	13	27360-76	15	29228-80	17
24032-70	9	25225-70B	11	26327-68	13	27361-76	15	29230-85	17
	51	25258-80B	11	26328-74	13	27362-76	15	29242-83	15

## NUMERICAL INDEX

Part No.	Page	Part No.	Page	Part No.	Page	Part No.	Page	Part No.	Page
29250-78A	15	31506-79B	135	33096-54B	29	33332-79	33	34186-76	31
29252-86B	17	31524-80	27	33114-79	41	33334-85	41	34191-79C	33
29259-83A	17	31531-69	23	33119-79A	33	33337-83	39	34193-79C	33
29259-86	17	31564-83	27	33151-80	29		51	34195-79C	33
29264-86	136	31570-73	27	33152-59	29	33350-36	29	34461-72	31
29269-83	17	31572-79	23	33158-80	31	33358-36	29	34464-86	41
29290-83	17	31572-86	25	33163-65B	45	33391-36	29	34468-86A	137
29290-86	17	31575-73	27	33165-80	31	33393-50	29	34476-72	31
29954-71	19	31576-73	27	33166-80	31	33396-39	29	34494-74C	31
29957-81B	19	31577-73	27	33167-79	31	33429-80	37	34517-80	31
29960-35	19	31578-73	27	33170-79A	31	33430-50	29	34518-80	31
29961-55	19	31579-73	27	33171-79A	31	33438-50	29	34564-74A	35
29965-81A	19	31580-73	27	33174-79	31	33560-75	29	34574-79	35
29983-73	19	31581-73	27	33176-79	31	33630-70	139	34609-52	35
31300-84	25	31582-73	27	33177-79	31	33638-70	35	34611-65	35
31310-80A	25	31583-73	27	33180-77	29	33642-89	139		139
31311-80	25	31584-73	27	33185-79	31	33660-74A	35	34614-74	35
31312-80	25	31585-73	27	33187-79	31	33660-85	35	34652-80	31
31320-80	25	31586-73	27	33188-79	31	33664-81	35	34655-79	31
31321-80	25	31609-80	21	33189-63	29	33668-86	139	34656-79	31
31340-80	25	31614-83	21		57	33683-80	35	34658-79	31
31341-80	25	31727-72	21		85		85	34659-79	31
31387-80	25	31727-85	21		86	33683-86A	85	34714-82A	37
31397-80	25	31800-78A	21		87	33683-87A	35	34731-86A	41
31433-84A	99	31981-65B	21	33190-79	31	33715-85	33	34732-86A	137
31435-65B	135	31983-71A	21	33196-79	31	33728-82A	33	34824-79	31
31438-65A	135	31986-65C	21	33197-79	31		35	34904-86	41
31439-65A	135	32000-37A	21	33198-79	31	33850-85	35	35025-79	43
31439-84	135	32311-83	21		135	33871-67	35	35026-79A	43
31440-65	135	32400-80A	21	33199-79	31	33871-85	35	35027-79A	43
31441-65A	135	32402-83	21	33201-79	31	33895-82	139	35028-79	43
31443-65A	23	32405-88	21	33205-80	33	33900-59	41	35029-35A	43
	25	32504-80	11	33206-80	33		135	35039-30	37
31444-65A	135		21	33207-80	33	33901-79	31	35039-84	37
31445-65A	23	32524-83	11	33208-80	33		135	35039-85	37
31445-85	23		21	33209-80	33	34020-79B	31	35042-85	43
31452-65A	135	32535-48	31	33210-80	33	34040-52	31	35046-36	37
31473-86	25	32591-80	11	33211-80	33	34062-52	31	35050-40	37
	99		21	33212-80	33	34068-52A	31	35064-79	43
31474-86	99	32604-78	21	33276-70	37	34082-79	33	35067-84	39
31475-77	138	32606-82	11	33277-36A	29	34083-79	33		39
31478-65A	23		21		37	34084-86	33	35068-79	33
	25	33043-80	41	33288-37	29	34085-79A	33	35070-84	39
	99		135	33290-38	29	34086-79	33	35076-79	41
31479-83	27	33048-72	57		37	34087-79	33	35077-86A	41
31480-83	27		65		45	34088-79	33		137
31482-70	23		86	33291-36	29	34089-79	33	35078-79	41
31482-86	25		87		37	34090-84	37	35079-82A	39
31485-65	23	33060-79	29		45	34091-85	43	35079-84	39
	25	33078-80	29	33295-36	29	34158-36	31	35094-65	39
31493-67	23	33080-36	29		37	34159-36	31	35100-79	37
31502-65	23	33082-16	29	33298-65	37	34168-52	31	35111-80	37
	25	33085-36	29	33318-85	99	34179-33	31	35211-36	39
31503-65	25	33085-74	29	33320-79A	33	34180-33	31		41
31503-70	23	33086-74	29	33326-79	33	34184-79	31		51



## NUMERICAL INDEX

Part No.	Page	Part No.	Page	Part No.	Page	Part No.	Page	Part No.	Page
35282-79	37	37084-79	41	37902-86	47	40952-82A	67		59
35306-59	37	37087-86	137	37903-84	47	40957-86	139	42320-82	59
35J36-74	31	37088-85	43	37904-84	47	40975-86	67	42326-82	59
35337-36	37		47	37905-84	47	40976-86	67	42330-82	59
35365-36	37	37089-84	43	37906-84	47	41015-82A	69	42374-82B	57
35440-38	37		47	37907-84	47	41033-82	57		59
35614-80	39	37090-84	43	37930-68A	45		59	42375-82	139
35622-79A	43		47	37931-84	47	41039-82	61	42376-77A	57
35625-79A	43	37091-80	41	37975-81	45	41057-83	137		59
35626-79A	43	37096-85	41	37975-84	47	41110-79A	67	42381-82	139
35629-79	43		49	38010-41	45	41123-79	63	42389-79	59
35632-79	43	37100-84	41	38605-86	49		65		86
35652-79A	41	37101-84	41	38608-82B	49		67	42394-65	59
35665-36A	39	37102-84	41	38611-86	139		69	42396-79	59
35716-84	39	37104-84	137	38618-68C	49	41191-74	99	42399-82	59
35717-74	39	37228-75	45	38622-87	142	41197-73	51	42407-86	139
35751-79	39	37285-75A	45	38712-68	49		67	42425-79	59
35777-79	39	37285-84	47	39974-84	51	41470-73A	51	42428-82	59
35789-36	39	37312-75	43	39976-65B	51		67	42431-86	139
35791-36	39		45	39990-65	51		67	42433-83	59
35810-36	39		47	39992-65C	51	41552-73	67	42435-79	59
35811-36	39	37313-60	43	39993-65	51		69	42448-82A	57
35812-36	39		45	39996-65	51	41556-86	137	42453-82A	139
35850-84	9		47	39998-65	51	41570-77	77	42455-80	57
	51	37357-41	45	40003-79	51		79		59
35851-84	9	37357-84	47	40007-36A	51	41580-79	67	42455-82	139
	51	37361-41	45	40023-86	51		69	42470-82B	57
35852-84	9	37496-85	45	40025-77	51	41583-84	81		59
	51	37496-84	47	40028-15E	51	41584-86	140	42507-82	57
35875-36	39	37503-41	45	40029-15E	51	41592-79	67		85
35876-36	39	37523-15A	45	40052-65	51		69	42507-86	57
35877-36	39		47	40053-65	51	41595-73	67		85
35878-36	39	37523-85	47	40101-80	51	41595-86	67	42515-82	57
35879-36	39	37549-41	45	40210-85A	41	41665-82	61	42522-82	57
35882-36	39	37550-41B	45		51	41713-86	139	42524-82	57
35883-36	39	37550-84	47	40212-80C	39		139	42526-82	57
35884-36	39	37566-58	45		51	41731-82	53	42527-82	59
35915-36	39	37567-41A	45	40221-85	51	41739-84	53		109
35961-52	39	37574-44	45	40221-85A	67	41745-79	139	42531-82	57
36048-76A	39	37576-41	45		69	41747-82A	53	42532-82	57
36801-79	41	37581-47	45		137	41791-79A	67	42534-82	57
36952-67	139	37583-41	45	40275-83	51		69		59
36964-67	139	37585-41	45	40299-83	51	41800-81A	57	43001-79	63
37054-79A	49	37702-70A	45	40375-70	51		59	43005-86	140
37070-39B	37		51	40384-83A	51	41804-84A	57	43024-73B	63
	45	37702-84	47	40392-70	51	41814-76A	65	43025-73B	63
37071-79	41		51	40910-84A	63	42257-82	59	43032-40B	67
37072-79	29	37707-84	47	40918-82	57	42269-30	35	43041-85	63
	37		51	40920-82	57		57		67
	41	37741-82	39	40922-79	57		59	43053-86	140
37074-38A	37	37816-41	45	40932-81	51	42269-70	139	43057-80A	63
	45	37850-68	45		67	42299-82	59	43067-86	140
37075-84	137	37871-41	45		69	42301-79A	139	43085-81	67
37077-68	45	37871-84	47		137	42305-86	139		140
37083-80A	41	37901-84	47	40951-82	67	42309-70	57	43150-83	55

## NUMERICAL INDEX

Part No.	Page	Part No.	Page	Part No.	Page	Part No.	Page	Part No.	Page
43157-83A	69	44146-82	61	45403-84	75	45873-84	71	47519-83A	63
43233-84	79	44197-77	55	45410-84	73	45874-84	71		65
43283-86	31		61		75	45875-84	71		67
43312-84	63	44200-82	61	45412-75	73	45903-84A	75		69
43346-83	63	44201-82	61		75	45904-84A	75	47537-84	79
43358-83A	63	44207-82	61	45413-84	73	45906-84	73	47537-86	61
	65	44208-82	61		75		75	47548-84	81
	77	44209-82	61	45416-84	73	45908-80	73	47554-73	77
43567-79	67	44211-82	61		75		75		79
	69	44212-82	61	45417-84	71	45912-84	73	47573-86	140
43578-85	9	45004-85	53	45418-84	71		75	47577-86	140
43601-78A	63	45005-85	53	45419-80	71	45914-84	73	47579-86	140
	67	45012-82	53	45420-80	71		75	47698-65B	77
43602-78A	63	45015-82	53	45456-86	140	45915-86	140		79
	67	45017-82A	49	45583-83	53	45916-86	140	47698-86A	81
43603-78A	63	45019-85	53	45603-86	140	45917-86	140	47716-86	57
	67	45021-86	49	45608-84	73	45918-86	140	47724-84	88
43604-78	69	45031-82	53		75	45930-86	140	47726-84	86
43605-78	69	45032-82	49	45611-86	140	45931-86	140	47728-84	88
43606-78	69		53	45640-84A	71	45932-86	140	47730-77	77
43619-84	63	45036-82	49	45648-85	71	45933-86	140		79
43623-78	63	45039-88	49		111	45934-86	140	48030-84	88
	65	45042-82	53	45665-84B	71	45940-84	71	48030-86	88
43624-78	63	45044-82	49	45670-80	71	45964-86	140	48033-84	86
	65		53	45672-80	71	45982-73	73	48130-86	81
43625-78	63	45051-82	53	45717-63	71		75	48140-84	71
	65	45057-82	53	45718-60	71	45987-84	73	48155-30	131
43626-84	65	45072-87	53	45718-71	73	45993-73	73	48300-60	71
43654-86A	67	45092-66A	15		75		75		73
	69	45095-85	9	45733-48	71	45994-84	73		75
	140	45112-84A	53	45736-78B	73		75	48311-60	77
43652-80B	63	45113-84	53		75	45997-73	73		79
43671-84	63	45121-88	53	45751-71A	73		75		81
43672-84	63	45124-84	53		75	45998-73	71	48315-60	73
43883-84	63	45152-78A	57	45762-86	140		73		75
	65		59	45782-72A	73		75	48330-48A	71
44020-83	55	45154-84	57		75	46004-84	71	48332-48B	71
44021-83	55	45156-84	57	45785-82	75	46006-84	71	48361-80	71
44022-83	55	45382-83	73	45788-84	73	46020-84	71		73
44046-84	55		75	45790-80	73		73		75
44047-83	55	45386-83	73		75		75	48365-48A	71
44048-83	55		75	45830-48	9	46048-84	71		73
44050-82A	61	45387-83	73		13	47008-84	79		75
44053-83A	55		75		29	47008-86	61	49117-77	37
44054-83	55	45392-83	73		37	47013-85	77	49126-77B	87
44059-83	55	45396-84	73	45832-77A	71	47107-84	85	49127-77A	87
44060-83	55	45397-84	73	45834-77	71		86	49129-77	87
44061-83	55	45403-84	73	45838-77	71	47108-84	85	50005-85	83
44062-83	55		75	45842-77	71		86	50007-86	141
44063-83	55	45404-75	73	45845-77	71	47446-82	77	50011-30A	83
44065-83	55		75	45855-77	71	47498-82A	77	50013-85	83
44069-84	61	45405-75A	71	45858-77	71	47510-58	77	50015-74	83
44126-82	57		73	45859-77	71	47513-58	77	50018-85	83
44136-84A	63		75	45865-84	71	47517-58	77		141
	65	45407-83	75	45866-84	71	47519-72	77	50028-74A	83

## NUMERICAL INDEX

Part No.	Page	Part No.	Page	Part No.	Page	Part No.	Page	Part No.	Page
50035-74	83	54473-79	89	59125-86B	142	60005-77	97	61913-86	142
50040-80	83	54474-79	89	59129-86	142	60302-78	95	61915-86	142
50040-85	83	54475-79	89	59180-80	142	60303-84	95	62043-81A	125
50041-80A	83	54508-84	88	59181-80	142	60319-83	103	62150-85	136
50041-85	83	54508-86	88	59191-86	142	60348-65A	99	62161-75	101
50061-36E	83	54509-73A	89	59197-86	142	60352-86	81	62166-81	101
50061-85	83	54515-73	89	59210-86	142	60363-84	79	62167-81	101
50087-86	141	54520-84	88	59211-74	142	60363-86A	81	62172-75	101
50100-70	83	54520-86	88	59235-86	142	60386-84	95	62375-57	41
	99	54546-84	89	59254-72	71	60388-82	95	62498-84C	103
50614-66	141	54555-84	89		73	60400-74	35	62498-86A	103
50619-74A	141	54556-84	89		75	60414-84	99	62504-82A	105
50620-74	141	54569-84	89	59255-72	93	60421-84	99	62534-65	105
50621-79A	141	54704-65	89		95	60441-82A	99	62538-82	77
50635-82	141	54710-84	89	59626-84	142	60441-84	99	62563-65	103
50800-71B	86	56073-83	90	59646-80	95	60494-80	95		105
	86		121	59648-84A	79	60504-84	99		109
50900-72	85		123		81	60507-82A	99	62625-70A	105
50912-72	85	56081-82	90		93	60507-86A	99	62634-84	103
	86	56098-80	90	59658-79	142	60516-65A	23	62702-52	37
	87	56099-80	90	59682-78	95	60531-83B	99	62703-84	103
	86	56105-84	90	59686-78	95	60533-86	93	62703-85	103
50939-52	86		141	59687-84	95	60538-81D	99	62704-84	103
50940-52	86	56116-82	90	59692-84	79	60539-86	99	62707-84	103
50946-52	86	56117-82	90	59710-84	115	60543-86A	137	63500-68	17
50973-65	86	56119-77	90	59904-84	95	60549-70	99		103
50989-86	141	56122-77	90	59914-84	93	60559-80	23	63501-68	101
50990-86A	141	56124-77	90	59914-86A	93	60567-65B	99	63505-84	101
50991-86	140	56133-83	141	59924-80	93	60572-78A	99		119
50992-86	139	56153-73	90		95	60579-74	99	63515-86	103
51188-84	84	56158-73	90	59929-73	95	60593-74	99	63531-84	103
51188-86	84	56159-73	90	59939-84	95	60630-86A	137	63533-41	9
51192-83	84	56206-81A	90	59945-84	95	60639-84	93		13
51195-80	84		91	59954-84	93	60641-74	99		99
51652-83	84	56220-81B	90	59954-86	93	60668-84B	137	63536-84	105
52092-77	97		91	59955-84	93	60678-85	99	63539-84	105
52103-31	107	56323-81C	91	59955-86	93	61102-83A	101	63548-82	59
52179-85	84	56324-81C	91	59959-86	115	61103-83	101	63549-65A	105
52191-86	137	56394-74	123	59960-80	95	61109-85	101	63551-82	57
52495-88	84	56396-74A	91	59961-80	95	61155-84	101	63553-86	103
52498-85	84		123	59962-80	95	61150-80	101	63556-86	103
52499-85	84	56397-74C	91	59963-80	95	61161-85	101	63564-84	105
52501-84	84		123	59964-86	142	61211-84B	101	63572-86	103
52502-86	141	56402-83A	91	59968-85	115	61218-85A	101	63573-82	57
52683-74	86		123	59969-86	142		142	63587-84	105
52695-77	86	56508-76	91	59971-80	97	61228-84	101	63796-77A	138
52743-82A	84	56541-86	141	59983-75	97	61426-85	101	63802-84A	103
52744-82A	84	56542-86	141	59984-73	97		142	63805-80A	103
52771-82	84	56567-86	141		142	61640-84	101	63810-80A	105
	137	56569-86	141	59986-75	97	61641-84	101	63858-49	5
53156-86	90	57215-75	139		142	61647-85	101	65276-62	107
53439-79	129	58993-86	142	59988-72	97	61648-85A	101	65324-83	107
	142	59007-84	95	59993-80A	97	61660-85	101	65325-83	107
54321-85	63	59082-79	142	60001-55	97	61661-84	101	65328-83	107
	67	59111-74	95		142	61667-84	101	65347-85	107

## NUMERICAL INDEX

Part No.	Page	Part No.	Page	Part No.	Page	Part No.	Page	Part No.	Page
65380-34	107	67079-86A	143		115	70082-82	123	71158-86	127
65380-85	107	67086-85	129	68207-80	115	70085-80	119	71159-73A	127
65382-86	107	67091-85	129	68402-86	143	70092-84	123	71162-70	127
65383-84	107	67094-85	129	68406-86B	115	70093-84	123	71166-73	127
65383-85	107	67095-85	129	68407-86	115	70107-80	119	71182-47A	127
65395-86	107	67116-85	129	68435-84	115	70146-84	119	71240-80	127
65401-84	107	67118-87	125	68440-86	143	70155-84	119	71241-68B	138
65401-86	107	67119-85	129	68451-86	143	70191-73A	119	71241-68C	143
65410-83	107	67120-84B	125	68452-86	115	70196-86	142	71243-86	138
65411-80A	107	67122-85	129	68455-86	115	70197-86	141	71295-68	127
65447-86	142	67125-86A	143	68457-86	115	70205-84	119	71297-68	127
65459-84A	107	67127-84A	129	68462-64	125	70207-84	119	71300-68A	127
65460-86	138	67215-68	125	68477-73	115	70214-85	119	71300-79	127
65481-83A	107	67217-68	125	68480-73	115	70216-84	119	71425-77	133
65482-83	107	67239-83	53	68481-73	115	70216-85	119	71451-78	133
65603-84	107	67241-85	129	68482-73	115	70218-86A	123	71463-73A	135
65603-86	107	67242-85	129	68483-73	115	70218-87	123	71467-65	135
65702-86	107	67698-81A	111	68486-82A	115	70219-86A	123	71469-65B	135
65732-86	107		112	68487-82	115	70219-87	123	71473-77B	138
65774-85A	107	67713-86	142	68510-74B	143	70226-85	119	71501-73A	131
65991-82A	103	67719-63	112	68531-78	115	70244-85	119	71506-36A	131
	109	67725-63	112	68536-75	112	70246-85	119	71506-84	131
66000-80	109	67743-84	112	68543-64B	115	70256-84	119	71510-36A	131
66042-79A	138	67744-75	112	68550-83	115	70258-84	119	71516-36	131
66047-80A	103	67768-86	142	68578-64B	115	70259-84	119	71518-30	133
	105	67769-82	111	68578-84A	115	70262-79	119	71541-73	131
	109	67772-80	111	68582-73	125	70287-81	121	71541-84	131
66099-80	27	67773-80A	71	68797-68A	77		123	71550-75	133
	109		111	69016-76	117	70288-81	121	71552-75	133
66103-74A	103	67777-80A	111	69017-76	117		123	71554-75	133
	109	67788-82	111	69024-77	133	70461-67B	119	71560-36	131
66105-77	103	67790-82	111	69118-84	117	70504-81	91	71560-84	131
66191-80	109	67808-86	140	69125-65	117	70551-69	119	71562-36	131
66210-85	103	67809-75	112	69149-65	117	70552-69	119	71563-82A	123
66225-78	27	67815-59A	112	69543-85	119	70553-69	119	71564-82A	123
	109	67816-86	140	69549-85	135	70554-69	119	71567-82	123
66309-84	103	67819-86	140	69999-77	130	70555-69	119	71568-82A	123
66352-65	109	67820-86	140	70000-84	119	70556-71	119	71570-82A	123
66359-80	109	67823-84	111	70005-70	121	70558-71	119	71570-86A	123
66367-73	109	67823-85A	111	70008-86	81	70559-71	119	71571-82	123
66476-73A	109	67825-86	142		119	70576-68	121	71572-44	131
67020-85	129	67830-59	112	70009-85	119		125	71572-82A	123
67021-85A	129	67833-75	112	70011-84B	119	70579-65	121	71572-86A	123
67024-84A	125	67839-74	112	70016-65A	117		125	71573-82A	123
67027-81C	125		121	70022-83	119	70936-84	125	71574-82	123
67030-81D	125	67851-75	112	70027-83	119	70939-84A	125		130
67038-84	125	68007-77A	113	70037-82	123	70941-84A	127	71580-36	131
67067-76	138	68008-73A	113	70038-82	123		129	71580-84	131
	143	68025-73	113	70047-82	123	71090-64	127	71583-85	131
67068-76	125	68026-73	113	70049-83	119	71092-68A	127	71587-36	131
67069-76	125	68034-77	113	70050-83	119	71134-68	127	71795-63A	93
67070-76	125	68046-79	142	70054-84A	119	71141-68	127	71875-81	19
67075-57A	21	68047-79	142	70059-65B	119	71143-75	127	72023-51A	57
67077-85	129	68123-73	113	70069-83A	119	71144-75A	127		59
67078-85A	129	68168-89	113	70081-85	119	71145-75	127		130

## NUMERICAL INDEX

Part No.	Page	Part No.	Page	Part No.	Page	Part No.	Page	Part No.	Page
72034-71	121	99353-322	109						
72035-71	121								
72037-71	121								
72033-71	121								
72039-71	121								
	123								
72041-71	121								
72043-71	121								
72044-71	121								
	142								
	143								
72046-79	121								
72047-71	121								
72051-77	21								
	121								
72275-74	121								
72276-74	121								
72277-74	121								
72273-74	121								
72312-73	127								
72501-74	121								
72502-74	121								
74516-86	19								
74521-77	21								
	121								
74533-75B	19								
74534-80	19								
74536-77A	21								
	121								
74539-77A	21								
	121								
74589-73	130								
74598-73	130								
74599-77A	103								
	130								
83162-51	11								
90770-79	49								
91704-15	119								
91768-85	137								
91875-82	117								
91892-82	117								
92042-85	129								
92043-85	129								
92061-83	129								
92077-83	129								
95578-41	53								
	67								
95581-47	63								
	67								
95582-47	63								
	67								
95594-84	65								
	69								
99000-77	137								
99013-82	84								

