

**V-Twin MFG.**  
**ADJUSTABLE CHROME CENTER STAND**  
**FOR 1989-2008 TOURING**  
**VT No. 16-1101**

**This is a custom application and rider safety depends on proper installation. This product should only be installed by a knowledgeable and trained motorcycle technician. V-Twin Mfg. accepts no responsibility for improper installation.**

**Installation Instructions:**

1. Loosening the exhaust system may be required to gain access to the swing arm hardware. Refer to the service manual for exhaust system removal.
2. Support the engine with a suitable stand. Remove the passenger floorboards if installed. On 1998 to 1994 models, disconnect the ground strap from the frame support bracket under the transmission.
3. Remove and discard the left and right OEM lower swing arm bolts.

**WARNING:** Do not loosen, tighten or remove any of the bolts or set screws on the display stand.

4. Position the display stand under the bike and install the 7/16-14X1-1/4 Allen bolts and flat washers supplied in the kit (1) through the vertical arm of the stand, (A) into the lower swing arm hole as shown in figure 1. Do not tighten completely.

**NOTE:** On some 1989 & 1990 models the OEM bolts used were a fine thread. Use the 7/16-20X1-1/4 (NF) Allen bolts provided in kit. Refer to figure 1.

5. Place the top plate (2) under the transmission and over the frame support bracket (B). Swing the stand forward and up under the frame support (B) in line with the top plate (2).

**WARNING:** Failure to follow step 6 and 7 correctly can cause damage to the transmission pan.

6. Use the two 1/4-20X7/8 hex bolts and flat washers (3) to start the installation. An additional 1/4 inch spacer may be required to draw the stand to the top plate. Be careful not to contact the transmission pan with the bolts during this step.
7. As the stand is drawn into the frame support bracket (B) and the top plate (2), remove the 1/4-20X7/8 bolts (3) and replace with the 1/4-20X1/2 bolts. (4) Use Loctite for the final installation and torque the bolts to 10 ft. lbs. On 1998 to 1994 models re-connect the ground strap to one of the 1/4-20 bolts. (4)

**NOTE:** Insure there is 1/4 to 5/16 clearance between the oil pan and top plate.

8. Torque the Lower swing arm Allen bolts (1) to 30-35 ft. lbs.
9. Re-install the passenger floor, and exhaust system, and other components removed as necessary.
10. Make certain the Display Stand does not make contact with other components such as the exhaust system, foot pegs or floor boards.
11. Check for clearance on the brake lines and brake electrical harness.

**ADJUSTING THE STAND:**

1. When adjusting the stand make certain the flange side of the foot is facing rearward. A minimum of 3/4 inch thread must be engaged into the stand.
2. Adjust the feet to properly support the motorcycle level. Adjust the stand retracted and the motorcycle on the side stand. The feet may be adjusted to raise the back tire slightly off the ground if desired. Additional effort will be required to raise the motorcycle if adjusted with the rear tire off the ground.

**WARNING:** Insure the motorcycle is stable.

3. Lock the jam nuts.

**USING THE STAND:**

**WARNING:** When using the Display Stand do NOT park the motorcycle pointing downhill. The motorcycle may roll off the stand causing serious injury or damage.

**WARNING:** DO NOT START the motorcycle when using the stand.

**Engaging the stand:**

1. With the motorcycle on level ground, neutral and on the side stand, retract the left passenger floor board or foot peg.
2. With the left hand on the left grip, center the front wheel, place the right foot on the display stand foot lever (C) lowering the display stand to the ground.
3. Stand on the display stand foot lever (C) bringing the motorcycle level as you lift the rear of the motorcycle up and to the rear.

**Retracting the stand:**

1. Placing both hands on the grips, push the motorcycle forward. Use the front brake as necessary to gently lower the motorcycle off the stand. The spring will fully retract the stand as you roll forward.
2. Lower the side stand.

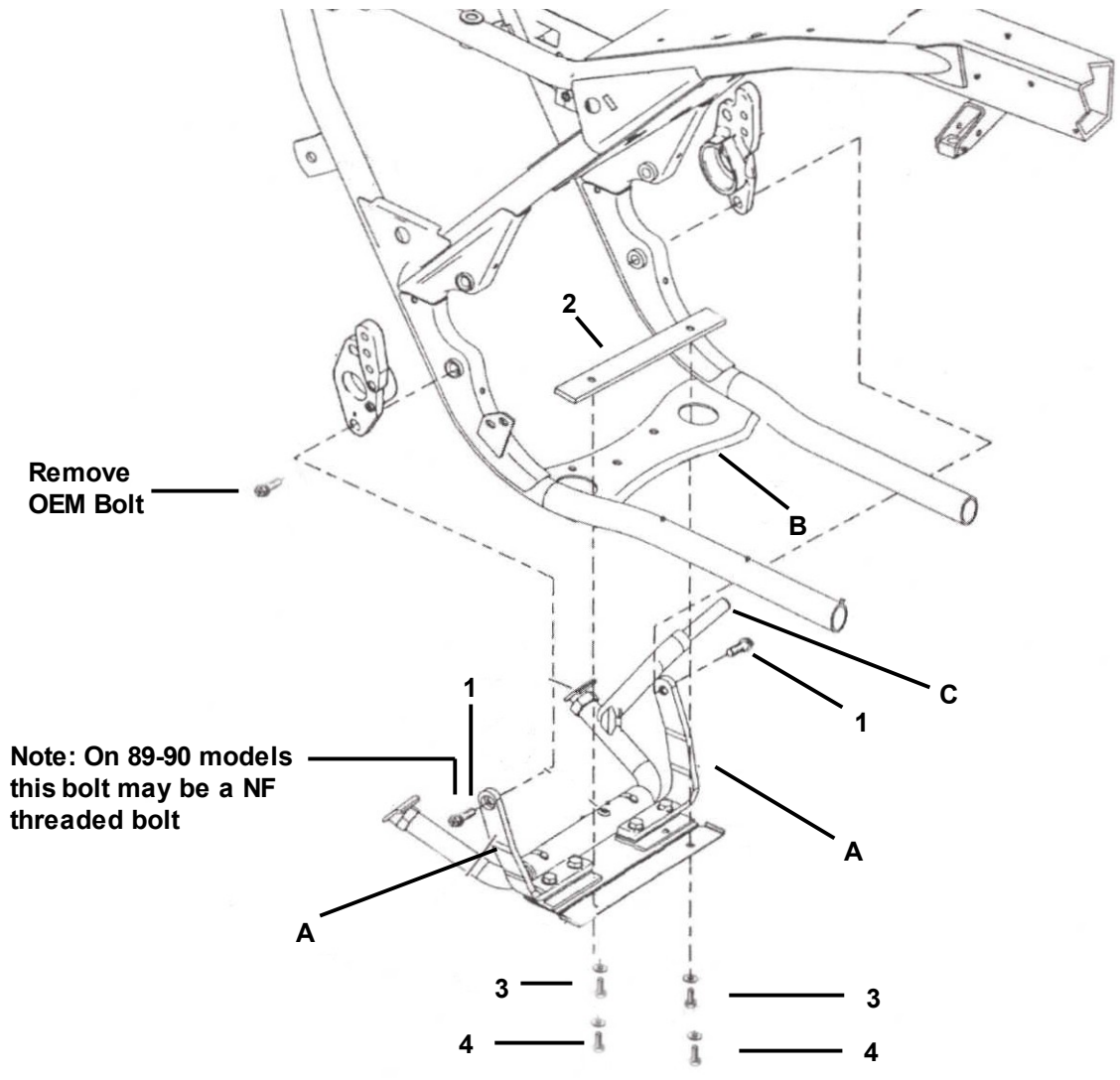

Figure 1